

POS-PHY Level 2 and 3 Compiler User Guide



The IP described in this document is scheduled for product obsolescence and discontinued support as described in [PDN0906](#). Therefore, Altera[®] does not recommend use of this IP in new designs. For more information about Altera's current IP offering, refer to Altera's [Intellectual Property](#) website.

Copyright © 2009 Altera Corporation. All rights reserved. Altera, The Programmable Solutions Company, the stylized Altera logo, specific device designations, and all other words and logos that are identified as trademarks and/or service marks are, unless noted otherwise, the trademarks and service marks of Altera Corporation in the U.S. and other countries. All other product or service names are the property of their respective holders. Altera products are protected under numerous U.S. and foreign patents and pending applications, maskwork rights, and copyrights. Altera warrants performance of its semiconductor products to current specifications in accordance with Altera's standard warranty, but reserves the right to make changes to any products and services at any time without notice. Altera assumes no responsibility or liability arising out of the application or use of any information, product, or service described herein except as expressly agreed to in writing by Altera Corporation. Altera customers are advised to obtain the latest version of device specifications before relying on any published information and before placing orders for products or services.

Chapter 1. About This Compiler

Release Information	1-1
Device Family Support	1-1
Features	1-2
General Description	1-3
Atlantic Interface	1-4
OpenCore Plus Evaluation	1-4
Performance and Resource Utilization	1-5

Chapter 2. Getting Started

Design Flow	2-1
POS-PHY Level 2 & 3 Walkthrough	2-2
Create a New Quartus II Project	2-2
Launch IP Toolbench	2-3
Step 1: Parameterize	2-5
Step 2: Set Up Simulation	2-9
Step 3: Generate	2-10
Simulate the Design	2-12
IP Functional Simulation Model	2-13
Testbench with the ModelSim Simulator	2-13
Testbench with NativeLink	2-13
Compile the Design	2-15
Program a Device	2-15
Set Up Licensing	2-16

Chapter 3. Functional Description

Example Configurations	3-2
Example Implementations	3-3
Internal Architecture	3-4
POS-PHY Interface	3-5
Packet Data Width Conversion	3-6
Packet FIFO Buffer	3-6
'B' Interface	3-6
OpenCore Plus Time-Out Behavior	3-6

Parameters	3-7
Interface Settings	3-7
FIFO Buffer & Clock Selector Options	3-7
Common B Clock	3-8
Parity Settings	3-8
Pass Through Mode	3-8
ParErr On Error Pin	3-9
FIFO Buffer Settings	3-9
Atlantic Interface FIFO Buffer Settings	3-13
FIFO Buffer Size	3-15
Address & Packet Available Settings	3-15
POS-PHY Level 3 Interfaces	3-15
POS-PHY Level 2 Interfaces	3-15
Base Address	3-16
SX Always	3-16
Interface Signals	3-16
Global Interface	3-17
POS-PHY Level 3 Interface	3-17
POS-PHY Level 2 Interface	3-22
Atlantic Interface	3-26
Timing	3-29
Signal Naming Convention	3-30
Compatibility	3-31
Example Packet Types	3-31
MegaCore Verification	3-31

Additional Information

Revision History	1-1
How to Contact Altera	1-1
Typographic Conventions	1-1

Release Information

Table 1–1 provides information about this release of the Altera® POS-PHY Level 2 and 3 Compiler.

Table 1–1. POS-PHY Level 2 and 3 Compiler Release Information

Item	Description
Version	9.1
Release Date	November 2009
Ordering Codes:	
■ POS-PHY level 2 PHY	IP-POSPHY/P2
■ POS-PHY level 2 link	IP-POSPHY/L2
■ POS-PHY level 3 PHY	IP-POSPHY/P3
■ POS-PHY level 3 link	IP-POSPHY/L3
Product IDs:	
■ POS-PHY level 2 PHY	0058 0071
■ POS-PHY level 2 link	0070 0071
■ POS-PHY level 2 PHY	0051 0071
■ POS-PHY level 2 link	0050 0071
Vendor ID	6AF7

 For more information about this release, refer to the [MegaCore IP Library Release Notes and Errata](#).

Altera verifies that the current version of the Quartus® II software compiles the previous version of each MegaCore® function. The [MegaCore IP Library Release Notes and Errata](#) report any exceptions to this verification. Altera does not verify compilation with MegaCore function versions older than one release."

Device Family Support

MegaCore functions provide either full or preliminary support for target Altera device families:

- *Full support* means the MegaCore function meets all functional and timing requirements for the device family and may be used in production designs
- *Preliminary support* means the MegaCore function meets all functional requirements, but may still be undergoing timing analysis for the device family; it may be used in production designs with caution.

Table 1–2 shows the level of support offered by the POS-PHY Level 2 and 3 Compiler to each Altera device family.

Table 1-2. Device Family Support

Device Family	Support
Arria™ GX	Full
Arria II GX	Preliminary
Cyclone®	Full
Cyclone II	Full
Cyclone III	Full
HardCopy® II	Full
HardCopy III	Preliminary
HardCopy IV E	Preliminary
Stratix®	Full
Stratix II	Full
Stratix II GX	Full
Stratix III	Full
Stratix IV	Preliminary
Stratix GX	Full
Other device families	No support

Features

- Conforms to POS-PHY level 2 and level 3 specifications
- Link-layer or PHY-layer POS-PHY interfaces
- Creates bridges between different POS-PHY interfaces
- Support for traffic up to a rate of 3.2 gigabits per second (Gbps) (POS-PHY level 3) or 832 megabits per second (Mbps) (POS-PHY level 2), such as SONET OC-48
- Single-PHY (SPHY) or up to 8-channel multi-PHY (MPHY) operation with polled and direct packet available options
- Atlantic™ interface that allows a consistent interface between all Altera cell and packet MegaCore functions
- Selectable POS-PHY interface bus widths (8/16/32 bit) and Atlantic interface bus widths (8/16/32/64 bit)—allowing translation between different bus types
- Parity generation/detection
- Configurable first-in first-out (FIFO) options: selectable FIFO width, depth, and fill thresholds.
- Easy-to-use IP Toolbench interface
- IP functional simulation models for use in Altera-supported VHDL and Verilog HDL simulators
- Support for OpenCore Plus evaluation

General Description

The POS-PHY Level 2 and 3 Compiler generates MegaCore functions for use in link-layer or physical layer (PHY) devices that transfer data to and from packet over SONET/SDH (POS) devices using the standard POS-PHY bus.

The POS-PHY Level 2 and 3 Compiler comprises separately configurable modules, which can be easily combined via the IP Toolbench to generate a highly parameterized module, allowing POS-PHY compliant interfaces (and non-standard interfaces) to be included in custom designs.

The compiler supports POS-PHY level 3 operating at up to 3.2 Gbps, and level 2 operating at up to 832 Mbps.

The POS-PHY Level 2 and 3 Compiler is compliant with all applicable standards, including:

- *POS-PHY Level 3 Specification, Issue 4, June 2000*
- *POS-PHY Level 2 Specification, Issue 5, December 1998*
- *Optical Internet working Forum (OIF), System Packet Interface Level 3 (SPI-3)*
- *Altera Corporation, Atlantic Interface Specification*

This allows efficient translation between the different formats, including mapping between different bus speeds and bus widths, as well as customizable FIFO buffer parameters.

The compiler allows configurations such as PHY-PHY, link-link bridges, or packet multiplexing MegaCore functions, and SPHY and MPHY applications. [Figure 1-1 on page 1-3](#) shows the possible interfaces. [Figure 1-2 on page 1-4](#) shows the possible bridges.

Figure 1-1. Interfaces

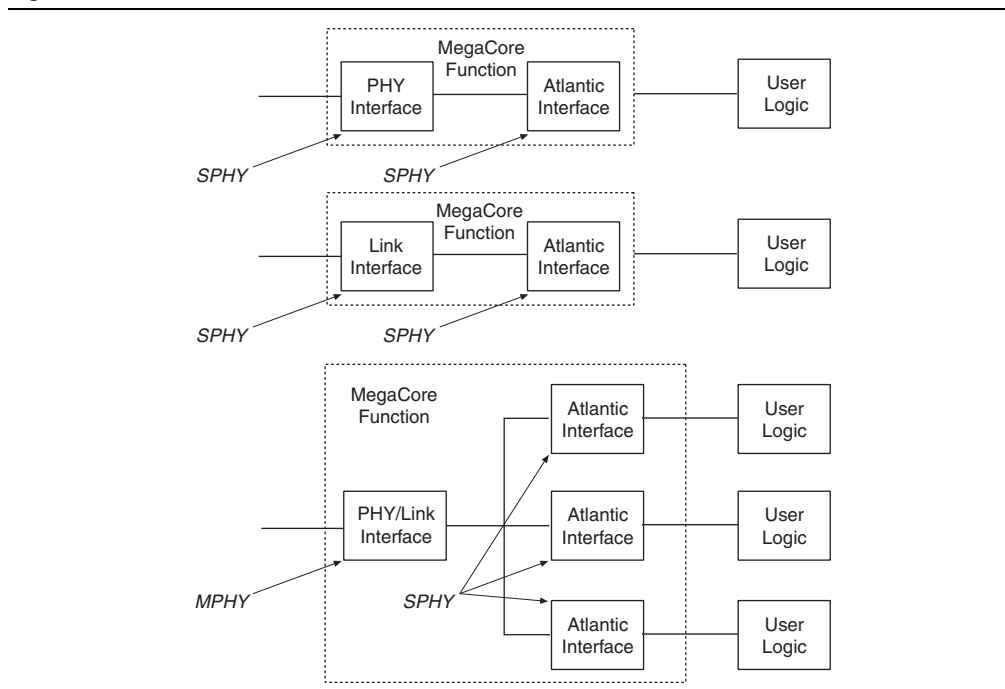
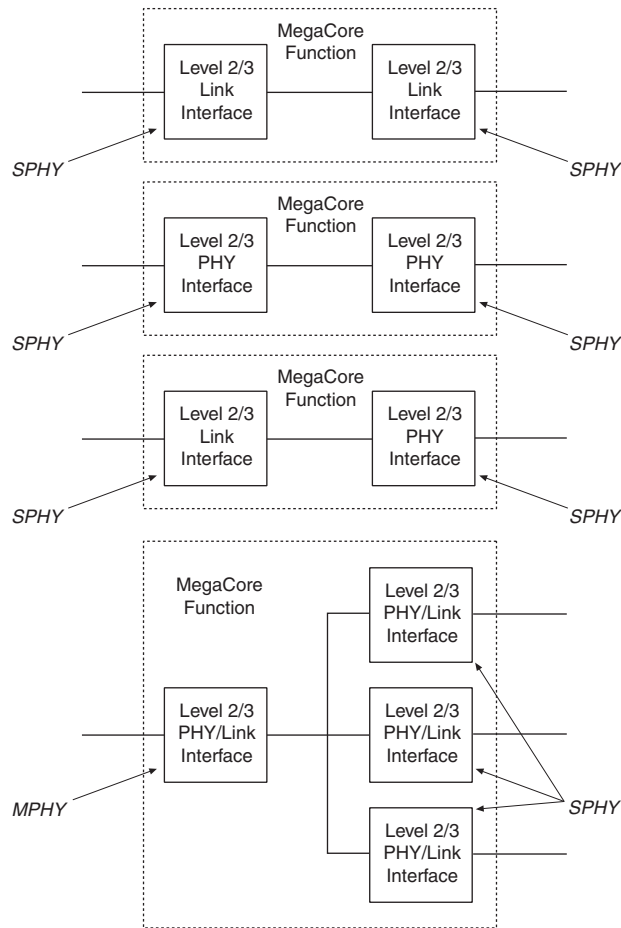



Figure 1-2. Bridges

Atlantic Interface

The Atlantic interface allows a consistent interface between all Altera cell and packet MegaCore functions. The Atlantic interface supports a point-to-point connection.

 For more information on the Atlantic interface, refer to [FS 13: Atlantic Interface](#).

OpenCore Plus Evaluation

With Altera's free OpenCore Plus evaluation feature, you can perform the following actions:

- Simulate the behavior of a megafunction (Altera MegaCore function or AMPPSM megafunction) within your system
- Verify the functionality of your design, as well as evaluate its size and speed quickly and easily
- Generate time-limited device programming files for designs that include megafunctions
- Program a device and verify your design in hardware

You only need to purchase a license for the megafunction when you are completely satisfied with its functionality and performance, and want to take your design to production.

 For more information on OpenCore Plus hardware evaluation using the POS-PHY Level 2 and 3 Compiler, see “OpenCore Plus Time-Out Behavior” on page 3–6 and AN 320: *OpenCore Plus Evaluation of Megafunctions*.

Performance and Resource Utilization

Table 1–3 through 1–7 show typical expected performance for SPHY and 4-port POS-PHY MegaCore functions. All results are push-button performance and use a FIFO buffer size of 512 bytes. These results were obtained using the Quartus® II software version for the following devices:

- Cyclone II (see tables for device details)
- Cyclone III (EP3C5F256C6 for POS-PHY level 3)
- Stratix III (EP3SL70F484C2 for POS-PHY level 2; EP3SL50F484C2 for POS-PHY level 3)
- Stratix IV (EP4SGX70DF29C2X)

Table 1–3. Performance—POS-PHY Level 2 Link Layer—Cyclone II Device

MegaCore Function	LEs	Memory Blocks	f _{MAX} (MHz)
		M4K	
Device: EP2C5F256C6			
SPHY receive	416	2	176
SPHY transmit	407	2	149
Device: EP2C15AF484C6			
MPHY 4-port receive	1,267	8	167
MPHY 4-port transmit	1,272	8	128

Table 1–4. Performance—POS-PHY Level 2 Link Layer—Stratix III Device

MegaCore Function	ALUTs	Logic Registers	Memory Blocks	f _{MAX} (MHz)
			M9K	
SPHY receive	177	348	2	344
SPHY transmit	210	326	2	310
MPHY 4-port receive	558	1,051	8	320
MPHY 4-port transmit	624	1,024	8	221

Table 1–5. Performance—POS-PHY Level 2 PHY Layer—Cyclone II Device (Part 1 of 2)

MegaCore Function	LEs	Memory Blocks	f _{MAX} (MHz)
		M4K	
Device: EP2C5F256C6			
SPHY receive	354	2	174

Table 1-5. Performance—POS-PHY Level 2 PHY Layer—Cyclone II Device (Part 2 of 2)

MegaCore Function	LEs	Memory Blocks		f_{MAX} (MHz)
		M4K		
SPHY transmit	285	2		159
Device: EP2C15AF484C6				
MPHY 4-port receive	1,175	8		161
MPHY 4-port transmit	1,126	8		139

Table 1-6. Performance—POS-PHY Level 2 PHY Layer—Stratix III Device

MegaCore Function	ALUTs	Logic Registers	Memory Blocks		f_{MAX} (MHz)
			M9K		
SPHY receive	122	309	2		340
SPHY transmit	123	234	2		346
MPHY 4-port receive	487	995	8		318
MPHY 4-port transmit	529	918	8		293

Table 1-7. Performance—POS-PHY Level 3 Link Layer—Cyclone III Device

MegaCore Function	LEs	Memory Blocks		f_{MAX} (MHz)
		M9K		
SPHY receive	379	2		165
SPHY transmit	377	2		139
MPHY 4-port receive	1,202	8		171
MPHY 4-port transmit	1,242	8		164

Table 1-8. Performance—POS-PHY Level 3 Link Layer—Stratix III Device

MegaCore Function	ALUTs	Logic Registers	Memory Blocks		f_{MAX} (MHz)
			M9K		
SPHY receive	149	330	2		234
SPHY transmit	164	313	2		205
MPHY 4-port receive	522	1,019	8		217
MPHY 4-port transmit	613	1,009	8		178

Table 1-9. Performance—POS-PHY Level 3 Link Layer—Stratix IV Device

MegaCore Function	ALUTs	Logic Registers	Memory Blocks		f_{MAX} (MHz)
			M9K		
SPHY receive	149	330	2		231
SPHY transmit	164	313	2		180
MPHY 4-port receive	522	1,019	8		254
MPHY 4-port transmit	613	1,009	8		174

Table 1-10. Performance—POS-PHY Level 3 PHY Layer—Cyclone III Device

MegaCore Function	LEs	Memory Blocks	f _{MAX} (MHz)
		M4K	
SPHY receive	350	2	174
SPHY transmit	365	2	173
MPHY 4-port receive	1,175	8	169
MPHY 4-port transmit	1,218	8	143

Table 1-11. Performance—POS-PHY Level 3 PHY Layer—Stratix III Device

MegaCore Function	ALUTs	Logic Registers	Memory Blocks	f _{MAX} (MHz)
			M9K	
SPHY receive	121	307	2	270
SPHY transmit	160	294	2	287
MPHY 4-port receive	489	999	8	245
MPHY 4-port transmit	587	984	8	231

Table 1-12. Performance—POS-PHY Level 3 PHY Layer—Stratix IV Device

MegaCore Function	ALUTs	Logic Registers	Memory Blocks	f _{MAX} (MHz)
			M9K	
SPHY receive	121	307	2	243
SPHY transmit	160	294	2	286
MPHY 4-port receive	489	999	8	222
MPHY 4-port transmit	587	984	8	260

Design Flow

To evaluate the POS-PHY Level 2 and 3 Compiler using the OpenCore Plus feature include these steps in your design flow:

1. Obtain and install the POS-PHY Level 2 and 3 Compiler.

The POS-PHY Level 2 and 3 MegaCore function is part of the MegaCore IP Library, which is distributed with the Quartus® II software and downloadable from the Altera® website, www.altera.com.

 For system requirements and installation instructions, refer to *Quartus II Installation & Licensing for Windows and Linux Workstations*.

Figure 2–1 on page 2–1 shows the directory structure after you install the POS-PHY Level 2 and 3 Compiler, where *<path>* is the installation directory. The default installation directory on Windows is `c:\altera\90`; on Linux it is `/opt/altera90`.

Figure 2–1. Directory Structure

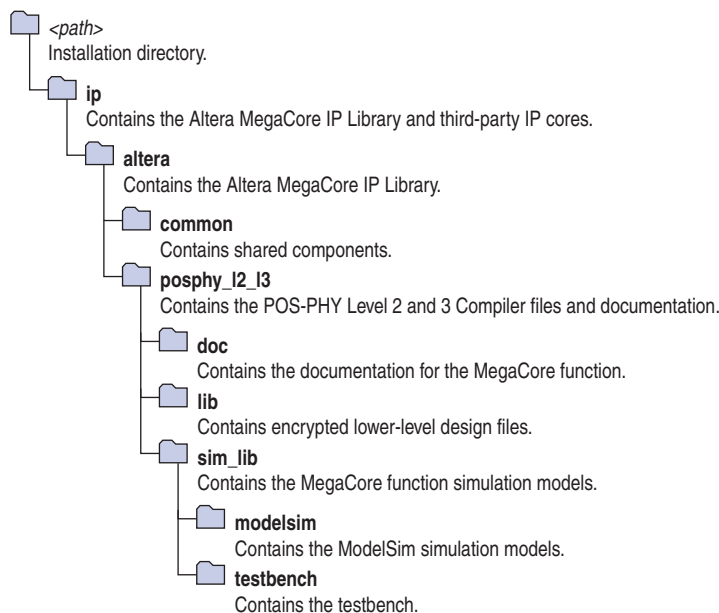

2. Create a custom variation of a POS-PHY Level 2 or 3 MegaCore function using IP Toolbench.

 IP Toolbench is a toolbar from which you can quickly and easily view documentation, specify parameters, and generate all of the files necessary for integrating the parameterized MegaCore function into your design.

3. Implement the rest of your design using the design entry method of your choice.
4. Use the IP Toolbench-generated IP functional simulation model to verify the operation of your design.

 For more information on IP functional simulation models, refer to the *Simulating Altera IP in Third-Party Simulation Tools* chapter in volume 3 of the *Quartus II Handbook*.

5. Use the Quartus II software to compile your design.

 You can also generate an OpenCore Plus time-limited programming file, which you can use to verify the operation of your design in hardware.

6. Purchase a license for the POS-PHY Level 2 and 3 Compiler.

After you have purchased a license for the POS-PHY Level 2 and 3 compiler, the design flow requires these additional steps:

1. Set up licensing.
2. Generate a programming file for the Altera® device(s) on your board.
3. Program the Altera device(s) with the completed design.
4. Perform design verification.

POS-PHY Level 2 & 3 Walkthrough

This walkthrough explains how to create a POS-PHY Level 2 or 3 MegaCore function using the Altera POS-PHY Level 2 and 3 Compiler IP Toolbench and the Quartus II software. When you finish generating a POS-PHY Level 2 or 3 MegaCore function, you can incorporate it into your overall project.

 IP Toolbench only allows you to select legal combinations of parameters, and warns you of any invalid configurations.

This walkthrough involves the following steps:

- [Create a New Quartus II Project](#)
- [Launch IP Toolbench](#)
- [Step 1: Parameterize](#)
- [Step 2: Set Up Simulation](#)
- [Step 3: Generate](#)

Create a New Quartus II Project

You need to create a new Quartus II project with the **New Project Wizard**, which specifies the working directory for the project, assigns the project name, and designates the name of the top-level design entity.

To create a new project follow these steps:

1. Choose **Programs > Altera > Quartus II** <version> (Windows Start menu) to run the Quartus II software. Alternatively, you can also use the Quartus II Web Edition software.
2. Choose **New Project Wizard** (File menu).
3. Click **Next** in the **New Project Wizard Introduction** page (the introduction does not display if you turned it off previously).
4. In the **New Project Wizard: Directory, Name, Top-Level Entity** page, enter the following information:
 - a. Specify the working directory for your project. For example, this walkthrough uses the `c:\altera\projects\pl2pl3_project` directory.

 The Quartus II software automatically specifies a top-level design entity that has the same name as the project. This walkthrough assumes that the names are the same.

- b. Specify the name of the project. This walkthrough uses **example** for the project name.
5. Click **Next** to close this page and display the **New Project Wizard: Add Files** page.

 When you specify a directory that does not already exist, a message asks if the specified directory should be created. Click **Yes** to create the directory.

6. Click **Next** to close this page and display the **New Project Wizard: Family & Device Settings** page.
7. On the **New Project Wizard: Family & Device Settings** page, choose the target device family in the Family list.
8. The remaining pages in the **New Project Wizard** are optional. Click **Finish** to complete the Quartus II project.

You have finished creating your new Quartus II project.

Launch IP Toolbench

To launch IP Toolbench in the Quartus II software, follow these steps:

1. Start the MegaWizard® Plug-In Manager by choosing **MegaWizard Plug-In Manager** (Tools menu). The MegaWizard Plug-In Manager dialog box displays.

 Refer to the Quartus II Help for more information on how to use the MegaWizard Plug-In Manager.

Figure 2–2. MegaWizard Plug-In Manager



2. Specify that you want to create a new custom megafunction variation and click Next.
3. Expand the **Communications** > **POS-PHY** directory then click **POS-PHY Level 2 & 3 Compiler**.
4. Select the output file type for your design; the wizard supports VHDL, and Verilog HDL.
5. The MegaWizard Plug-In Manager shows the project path that you specified in the **New Project Wizard**. Append a variation name for the MegaCore function output files `<project path>\<variation name>`. Figure 2–3 shows the wizard after you have made these settings.

Figure 2–3. Select the Megafunction

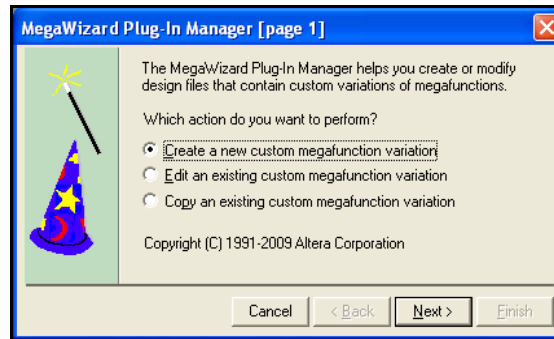
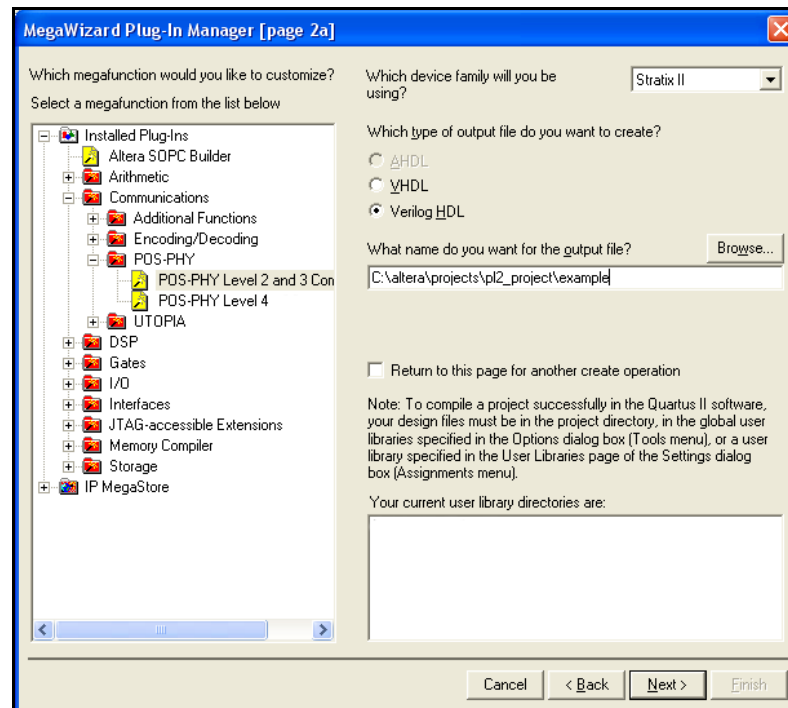

6. Click **Next** to launch IP Toolbench.

Step 1: Parameterize

To parameterize your MegaCore function, follow these steps:

1. Click **Parameterize** in the IP Toolbench (see [Figure 2-4 on page 2-5](#)).

Figure 2-4. IP Toolbench—Parameterize

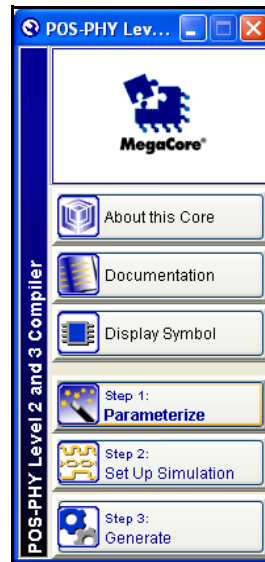

2. Select your architecture options where the POS-PHY 'A' interface is a data source or sink (see [Figure 2-5](#)).



 Source indicates that interface 'A' is an output from the MegaCore function. Sink indicates that interface 'A' is an input to the MegaCore function.

Figure 2-5. Select the 'A' Interface Direction

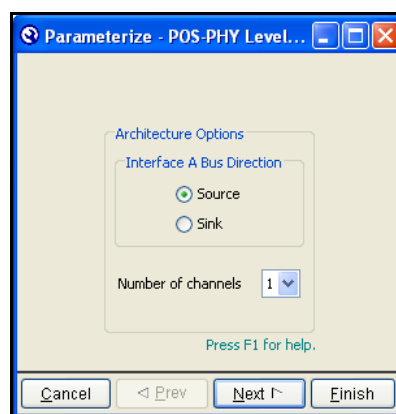

3. In a MPHY architecture there is a 'B' interface for each supported channel (maximum eight). Select the number of supported channels that you require.

 To create a design that supports source and sink data directions, you must run IP Toolbench twice, to create the source and sink designs separately.

4. Click **Next**.
5. Select your interface types (see [Figure 2-6](#)).
 - a. Select interface 'A' using the radio buttons.
 - b. Choose 'B' interfaces using the drop-down menus.

Figure 2-6. Select the Interface Types

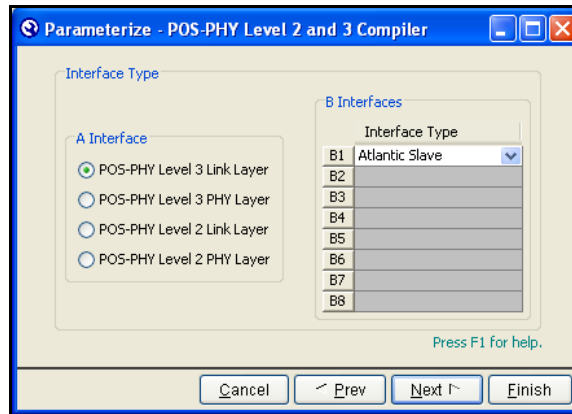

6. Click **Next**.
7. Choose the interface settings (see [Figure 2-7 on page 2-6](#)).

 *POS-PHY Level 3 Specification, Issue 4, June 2000* supports an 8- or 32-bit interface. Additionally this MegaCore function supports a 16-bit interface for POS-PHY level 3.

 *POS-PHY Level 2 Specification, Issue 5, December 1998* supports a 16 bit interface. Additionally, this MegaCore function supports 8- and 32-bit interfaces for POS-PHY level 2.

 The Atlantic interface can be 8-, 16-, 32-, or 64-bits wide.

Figure 2-7. Choose the Interface Settings



8. Click **Next**.
9. Select the parity settings of the interfaces (see [Figure 2-8](#)).

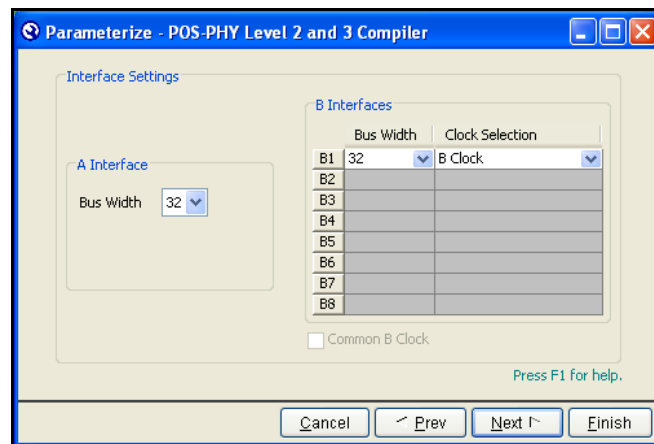

 If parity is used the polarity setting must be the same for all interfaces.

Figure 2-8. Select the Parity Settings

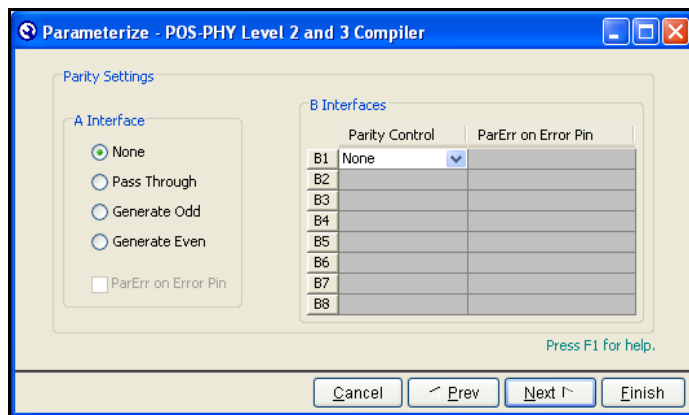

 For more information on the parity settings, see [“Parity Settings”](#) on page 3-8.

10. Click **Next**.
11. Choose the first-in first-out (FIFO) buffer settings (see [Figure 2-9](#)).

Figure 2-9. Choose the FIFO Buffer Settings

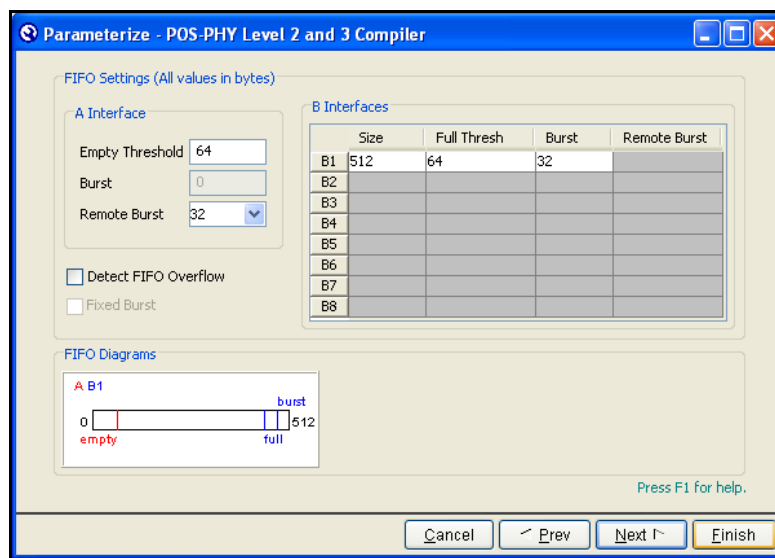

If you select the **Fixed Burst** option, you must also set the burst size by entering a value in the **Burst** field. Data is then sent in bursts of the specified burst size only, or in bursts containing an end of packet.

 The wizard indicates the minimum **Burst** value supported.

You must also adjust the FIFO thresholds so that the data sent to the FIFO for a burst is greater than the burst (an end of packet of packet flushes the FIFO). The minimum and maximum values are set as follows:

- The minimum value must be set at the size of the remote burst. If you set any value below this, it is automatically adjusted to the size of the remote burst.
- The maximum value is derived from the empty threshold. It must take into account the latency in the pipeline and the time that the core takes to decide to stop sending data. Therefore, the maximum burst size is calculated as follows:

$$('A' \text{ interface empty threshold in bytes}) - (5 \times \text{fifo_byte_width})$$

Where `fifo_byte_width` is the width in bytes of the FIFO (4 for a 32-bit data width).

 For more information on the FIFO buffer settings, see [“FIFO Buffer Settings”](#) on page 3–9.

12. Click **Next**.

13. Choose the address and packet available settings (see [Figure 2–10](#)).

Figure 2–10. Choose the Address and Packet Available Settings

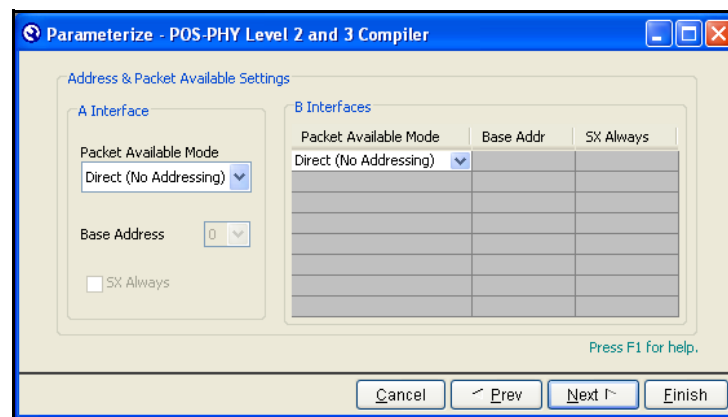

 For more information on the address and packet available settings, see [“Address & Packet Available Settings”](#) on page 3–15.

14. Click **Next**.

15. IP Toolbench shows the product order codes (see [Figure 2–11](#)). Click **Finish**.

Figure 2-11. Product Order Code

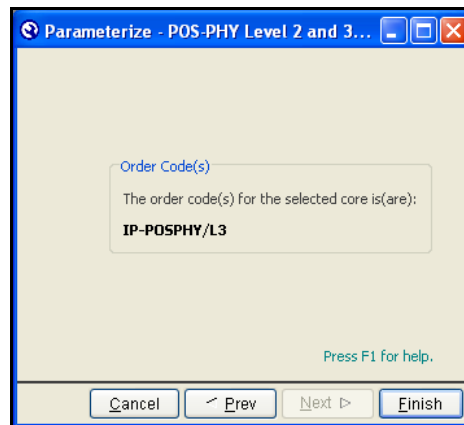

Step 2: Set Up Simulation

An IP functional simulation model is a cycle-accurate VHDL or Verilog HDL model produced by the Quartus II software. It allows for fast functional simulation of IP using industry-standard VHDL and Verilog HDL simulators.



You may only use these simulation model output files for simulation purposes and expressly not for synthesis or any other purposes. Using these models for synthesis will create a nonfunctional design.

To generate an IP functional simulation model for your MegaCore function, follow these steps:

1. Click **Set Up Simulation** in IP Toolbench (see [Figure 2-12 on page 2-9](#)).

Figure 2-12. IP Toolbench—Set Up Simulation

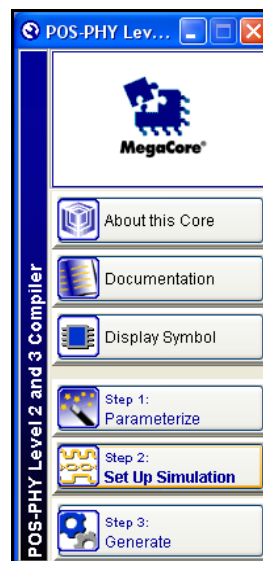

2. Turn on **Generate Simulation Model** (see [Figure 2-13](#)).

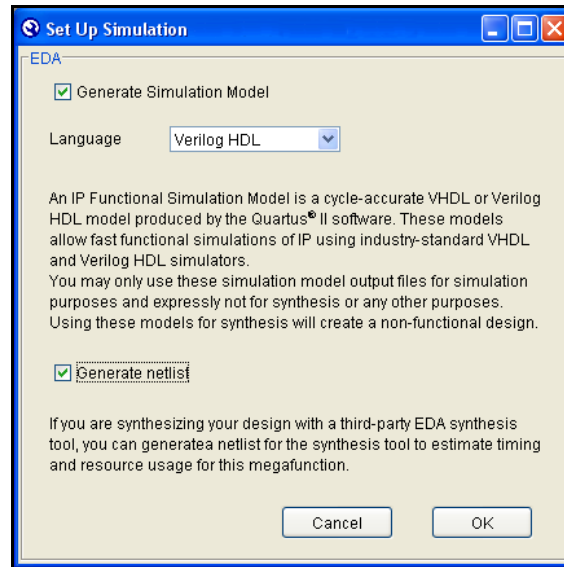
Figure 2-13. Generate Simulation Model

3. Choose the language in the Language list.
4. Some third-party synthesis tools can use a netlist that contains only the structure of the MegaCore function, but not detailed logic, to optimize performance of the design that contains the MegaCore function. If your synthesis tool supports this feature, turn on **Generate netlist**.
5. Click **OK**.

Step 3: Generate

To generate your MegaCore function, follow these steps:

1. Click **Step 3: Generate** in IP Toolbench (see [Figure 2-14](#)).

Figure 2-14. IP Toolbench—Generate

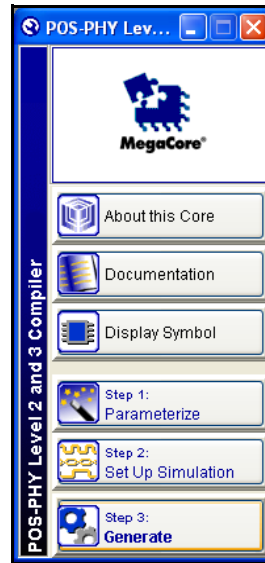

Figure 2-15 on page 2-11 shows the generation report.

Figure 2-15. Generation Report

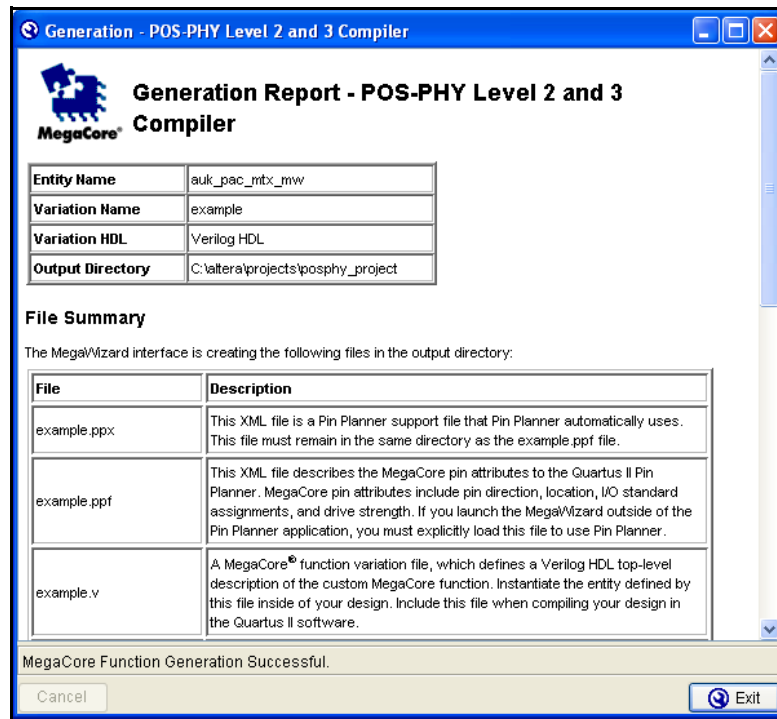

Table 2-1 describes the generated files and other files that may be in your project directory. The names and types of files specified in the IP Toolbench report vary based on whether you created your design with VHDL or Verilog HDL.

Table 2-1. Generated Files

Extension	Description
<variation name>.syn.v or <variation name>.syn.vhd	A timing and resource netlist for use in some third-party synthesis tools.
<variation name>.bsf	Quartus II symbol file for the MegaCore function variation. You can use this file in the Quartus II block diagram editor.
<variation name>.cmp	A VHDL component declaration file for the MegaCore function variation. Add the contents of this file to any VHDL architecture that instantiates the MegaCore function.
<variation name>.ppf	This XML file describes the MegaCore function pin attributes to the Quartus II Pin Planner. MegaCore function pin attributes include pin direction, location, I/O standard assignments, and drive strength. If you launch IP Toolbench outside of the Pin Planner application, you must explicitly load this file to use Pin Planner.
<variation name>.ppx	This XML file is a Pin Planner support file that Pin Planner automatically uses. This file must remain in the same directory as the <variation name>.ppf file.
<variation name>.vhd or <variation name>.v	A MegaCore function variation file, which defines a VHDL or Verilog HDL top-level description of the custom MegaCore function. Instantiate the entity defined by this file inside your design. Include this file when compiling your design in the Quartus II software.
<variation name>.vo or <variation name>.vho	VHDL or Verilog HDL IP functional simulation model.

- After you review the generation report, click **Exit** to close IP Toolbench and click **Yes** on the **Quartus II IP Files** message.



The Quartus II IP File (.qip) is a file generated by the MegaWizard interface or SOPC Builder that contains information about a generated IP core. You are prompted to add this .qip file to the current Quartus II project at the time of file generation. In most cases, the .qip file contains all of the necessary assignments and information required to process the core or system in the Quartus II compiler. Generally, a single .qip file is generated for each MegaCore function and for each SOPC Builder system. However, some more complex SOPC Builder components generate a separate .qip file, so the system .qip file references the component .qip file.

You can now integrate your custom MegaCore function variation into your design, simulate, and compile.

Simulate the Design

You can simulate your design using the IP Toolbench-generated VHDL and Verilog HDL IP functional simulation models.



For more information on IP functional simulation models, refer to “[IP Functional Simulation Model](#)” on page 2-13 and the *Simulating Altera IP in Third-Party Simulation Tools* chapter in volume 3 of the *Quartus II Handbook*.

Altera also provides fixed example VHDL and Verilog HDL testbenches that you can use to simulate example sink or source POS-PHY systems. You can use a testbench as a basis for your own design. The testbenches can be used with the IP functional simulation models. The testbenches and associated files are located in the sim_lib\testbench directory.

IP Functional Simulation Model

This section tells you how to use the demonstration testbench with the ModelSim simulator or with other simulators using NativeLink.

 For more information on NativeLink, refer to the *Simulating Altera IP in Third-Party Simulation Tools* chapter in volume 3 of the *Quartus II Handbook*.

Testbench with the ModelSim Simulator

To use an example testbench with IP functional simulation models in the ModelSim simulator, follow these steps:

 The testbench includes pregenerated Verilog HDL IP functional simulation models.

1. Start the ModelSim simulator.
2. Change the directory to the `sim_lib\modelsim` directory.
3. For VHDL type the following command:

```
do compile_pl3_link_source_fixed_example_vlog_ipfs.tcl←
```

or for Verilog HDL type the following command:

```
do compile_pl3_link_source_fixed_example_vhdl_ipfs.tcl←
```

 For the sink example, replace `source` with `sink`.

Testbench with NativeLink

You can run receive and transmit tests with third-party IP functional simulators using NativeLink, for VHDL or Verilog HDL. The following procedure describes a receive test for the Verilog HDL model.

To use the testbench with NativeLink, follow these steps:

1. Using the New Project Wizard in the Quartus II software, create a new project in the `\posphy_12_13\sim_lib\testbench\verilog` directory with the project name and top-level entity name of `auk_pac_mrx_pl3_link`.

 For the VHDL model, replace the `verilog` directory with the `vhdl` directory.

 For the transmit test, replace `mrx` with `mtx`.

2. Add the POS-PHY level 2 and 3 library:
 - a. On the Assignments menu click **Settings**.
 - b. Under **Category** click **Libraries**
 - c. In **Project library name** click ...
 - d. Browse to `\pos_phy_1213\lib` and click **Open**.
 - e. Click **Add**.
 - f. Click **OK**.

3. Add the following files to the project from the `\posphy_12_13\lib` directory:

- `auk_pac_gen_if.vhd`
- `auk_pac_functions.vhd`
- `auk_pac_components.vhd`

The files must be in the order shown, from top to bottom, which is the order of compilation. Use the **Up** and **Down** buttons in the **New Project Wizard: Add Files** window to order the files.

4. Check that the absolute path to your third-party simulation tool is set. Set the path from **EDA Tool Options** in the **Options** dialog box (Tools menu).
5. On the Processing menu, point to **Start** and click **Start Analysis & Elaboration**.

 If the analysis and elaboration is not successful, fix the error before moving to the next step.

6. On the Assignments menu, click **Settings**. The Settings window appears. Expand **EDA Tool Settings** and select **Simulation**.
7. In Tool name, select a simulator tool from the list.

In EDA Netlist Writer options, select **Verilog** from the list for **Format for output netlist** (Select VHDL if you are preparing a VHDL simulation).

In NativeLink settings, select the **Compile test bench** option and then click **Test Benches**. The Test Benches window appears.

8. In the Test Benches window, click **New**. The New Test Bench Settings window appears.
9. In the New Test Bench Settings window, enter the information described in [Table 2-2](#) (see also [Figure 2-16 on page 2-15](#)). To enter the files described in the table, browse to the files in your project.

Table 2-2. NativeLink Test Bench Settings

Parameter	Setting/File Name
Test bench name	<any name>
Top-level module in test bench	<code>auk_pac_mrx_ref (1)</code>
Design instance name in test bench	<code>mrx (1)</code>
Run for	100 ns
Test bench files	<code>auk_pac_mrx_ref_tb.v (2)</code>

Notes to table:

(1) Use `mtx` for Tx simulations.

(2) If you are preparing a VHDL simulation, use `auk_pac_mrx_ref_tb.vhd` in the `vhdl` directory.

[Figure 2-16](#) shows the testbench settings for a receive simulation.

Figure 2-16. Example of New Test Bench Settings for NativeLink

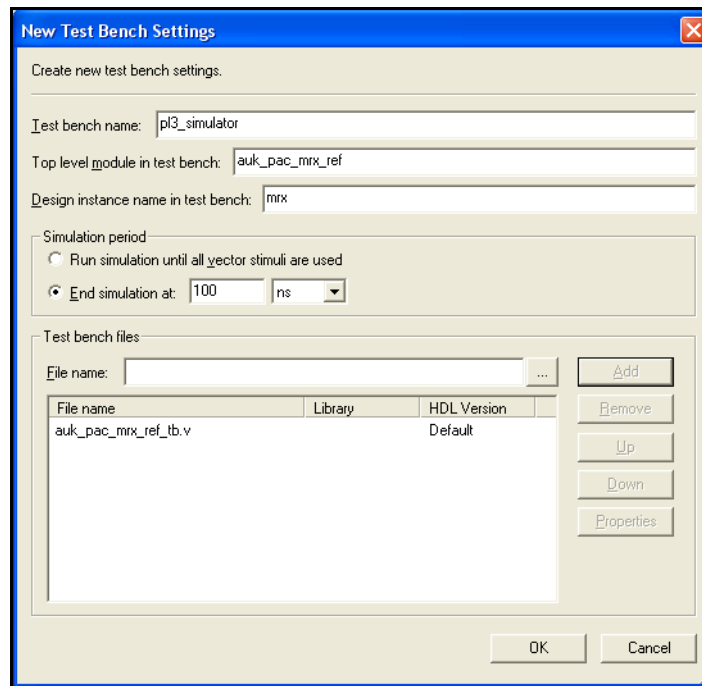

10. When you have entered the required information for your new testbench, click **OK** in the New Test Bench Settings window.
11. Click **OK** in the Test Benches window and then click **OK** in the Settings window.
12. On the Tools menu, point to **Run EDA Simulation Tool** and click **EDA RTL Simulation**. The simulation now begins with your chosen simulation tool.

Compile the Design

You can use the Quartus II software to compile your design. Refer to Quartus II Help for instructions on compiling your design.

Program a Device

After you have compiled your design, program your targeted Altera device, and verify your design in hardware.

With Altera's free OpenCore Plus evaluation feature, you can evaluate the POS-PHY Level 2 and 3 Compiler before you purchase a license. OpenCore Plus evaluation allows you to generate an IP functional simulation model, and produce a time-limited programming file.

 For more information on IP functional simulation models, refer to the *Simulating Altera IP in Third-Party Simulation Tools* chapter in volume 3 of the *Quartus II Handbook*.

You can simulate the POS-PHY Level 2 and 3 Compiler in your design, and perform a time-limited evaluation of your design in hardware.

- For more information on OpenCore Plus hardware evaluation using the POS-PHY Level 2 and 3 Compiler, see *“OpenCore Plus Evaluation”* on page 1–4, *“OpenCore Plus Time-Out Behavior”* on page 3–6, and *AN 320: OpenCore Plus Evaluation of Megafunctions*.

Set Up Licensing

You need to purchase a license for the MegaCore function only when you are completely satisfied with its functionality and performance and want to take your design to production.

After you purchase a license for the POS-PHY Level 2 and 3 MegaCore function, you can request a license file from the Altera website at www.altera.com/licensing and install it on your computer. When you request a license file, Altera emails you a **license.dat** file. If you do not have Internet access, contact your local Altera representative.

The POS-PHY Level 2 and 3 Compiler has two interfaces—an 'A' interface and one or many 'B' interfaces. Table 3-1 shows the possible interfaces.

Table 3-1. Possible Interfaces

'A' Interface	'B' Interface
PHY level 3 (SPHY or MPHY)	PHY level 3 (SPHY only)
PHY level 2 (SPHY or MPHY)	PHY level 2 (SPHY only)
Link level 3 (SPHY or MPHY)	Link level 3 (SPHY only)
Link level 2 (SPHY or MPHY)	Link level 2 (SPHY only)
	Atlantic master (SPHY only)
	Atlantic slave (SPHY only)

Figure 3-1 and 3-2 show example interfaces.



MegaCore® function data flow direction is from source to sink, that is, data flows from a physical layer (PHY) receive source to a link receive sink. A MegaCore function must have a minimum of one source and one sink interface.

Figure 3-1. Example MegaCore Function Interfaces

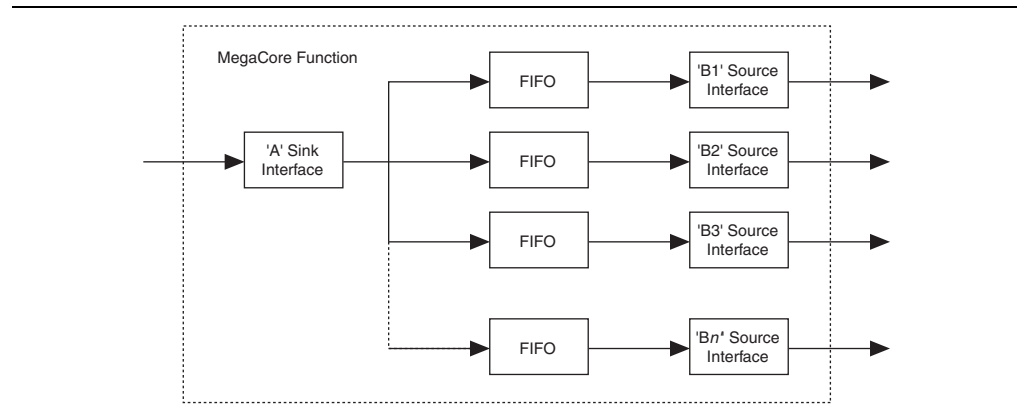
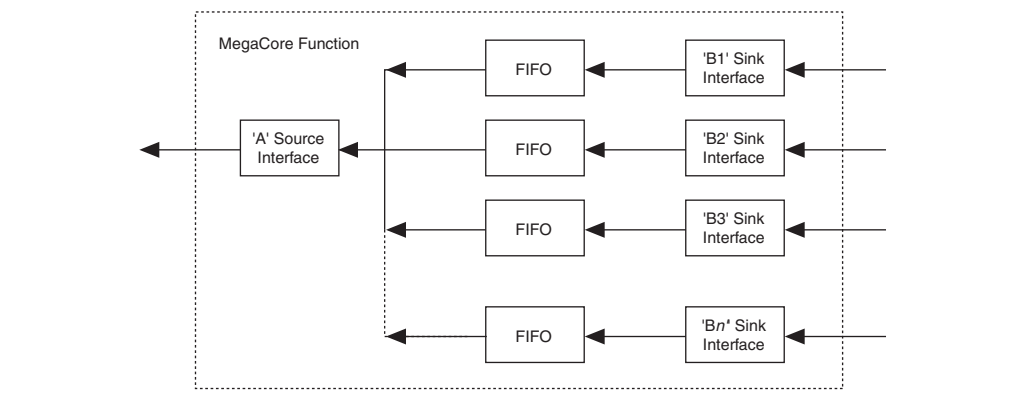
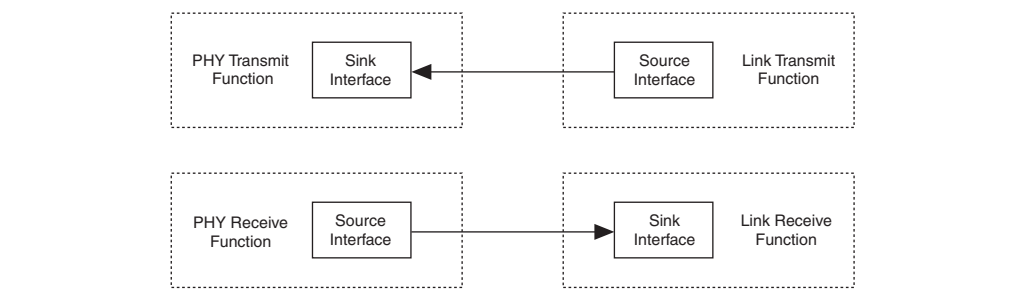

Figure 3-2. Example Interface



POS-PHY level 3 is a point-to-point system—transmit joins to transmit; channel 0 joins to channel 0, and so on (see [Figure 3-3](#)). POS-PHY level 2 is a unidirectional bus system.

Figure 3-3. Connecting POS-PHY Level 3 MegaCore Functions



Example Configurations

[Figure 3-4](#) on [page 3-2](#) shows a packet-processing function, which receives packets at one end from a POS-PHY PHY interface, processes them, and passes them on to a POS-PHY link interface.

Figure 3-4. Example Configuration—Use of the Atlantic Interface

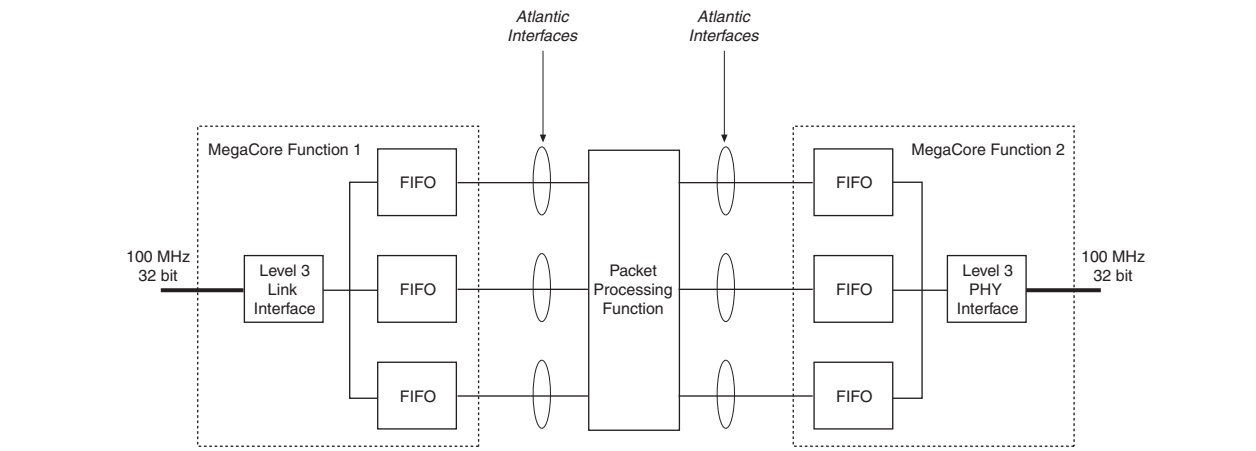

Figure 3-5 shows a bridging function with multiple lower-rate ports, which can be 8-bit POS-PHY level 3 or 16-bit POS-PHY level 2.

Figure 3-5. Example Configuration 2—POS-PHY Bridging Functions

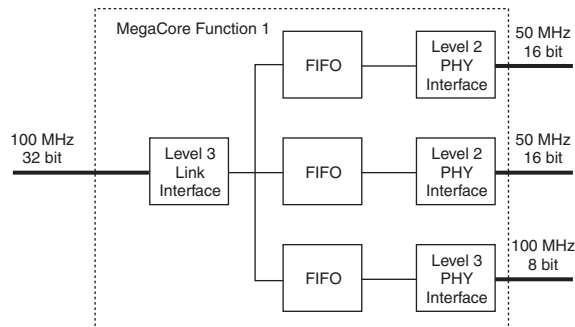
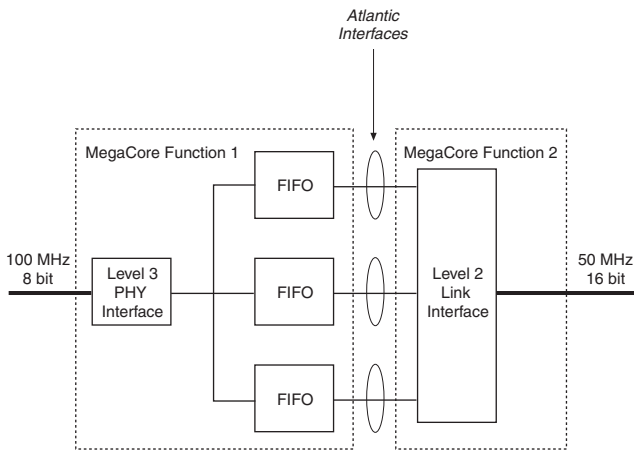

Figure 3-6 on page 3-3 shows an MPHY to MPHY POS-PHY bridge, which includes an MPHY POS-PHY level 2 interface and one first-in first-out (FIFO) buffer per supported address (MPHY).

Figure 3-6. Example Configuration 3—MPHY to MPHY Bridge



Example Implementations

Figure 3-7 shows the FPGA interfacing to an OC-48 framer.

Figure 3-7. Example Implementation

Figure 3-8 on page 3-4 shows the FPGA interfacing multiple POS-PHY level 2 devices to an OC-48 switch.

Figure 3-8. Example Implementation 2

Internal Architecture

The POS-PHY Level 2 and 3 Compiler comprises the following four MegaCore functions:

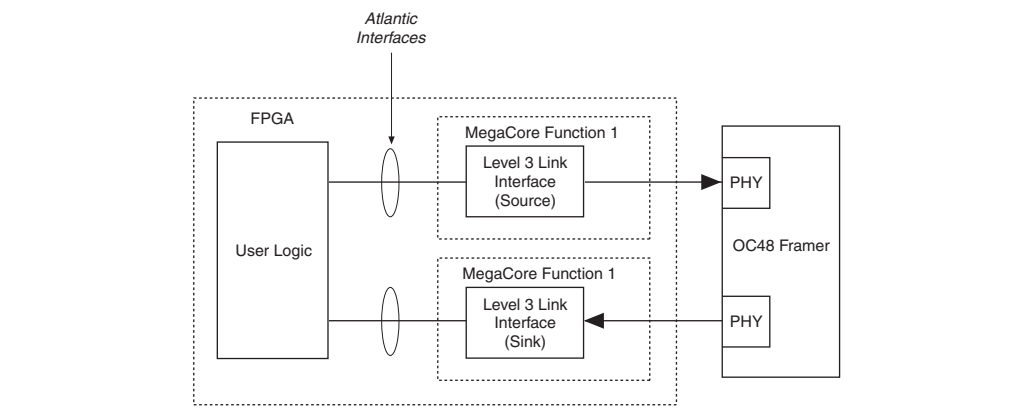
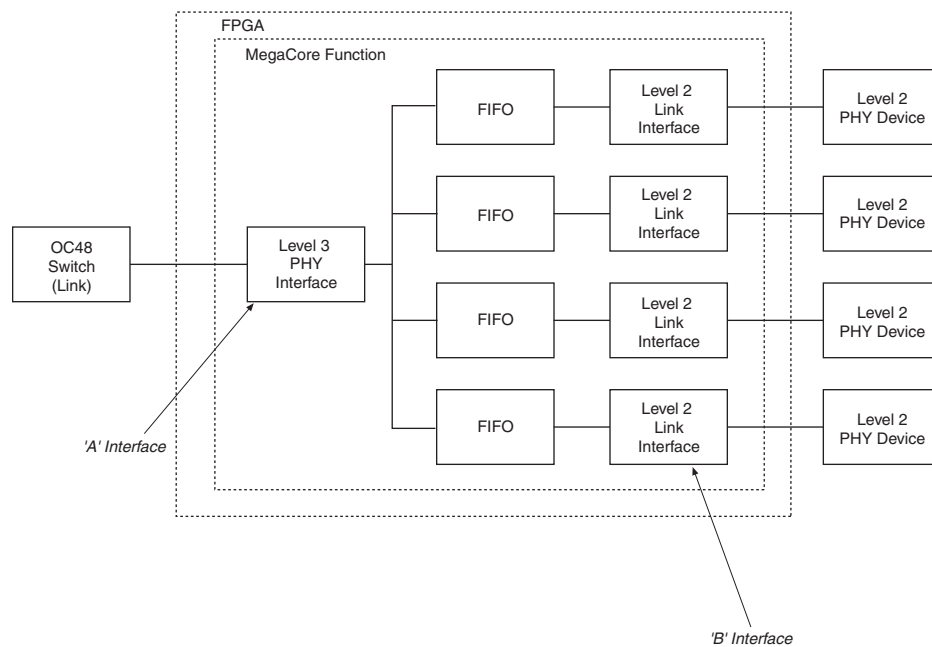
- POS-PHY level 2 link-layer
- POS-PHY level 2 PHY-layer
- POS-PHY level 3 link-layer
- POS-PHY level 3 PHY-layer

Each MegaCore function includes a separate receiver and transmitter, which can be instantiated in a single device or separate devices.

There are many similarities in the internal architecture of these blocks. The main difference is in the non-symmetrical handshaking on the physical interface between receive and transmit directions.

Figure 3-9 on page 3-5 shows the sink MegaCore function block diagram. Figure 3-10 on page 3-5 shows the source MegaCore function block diagram.

Figure 3-9. Sink MegaCore Function Block Diagram

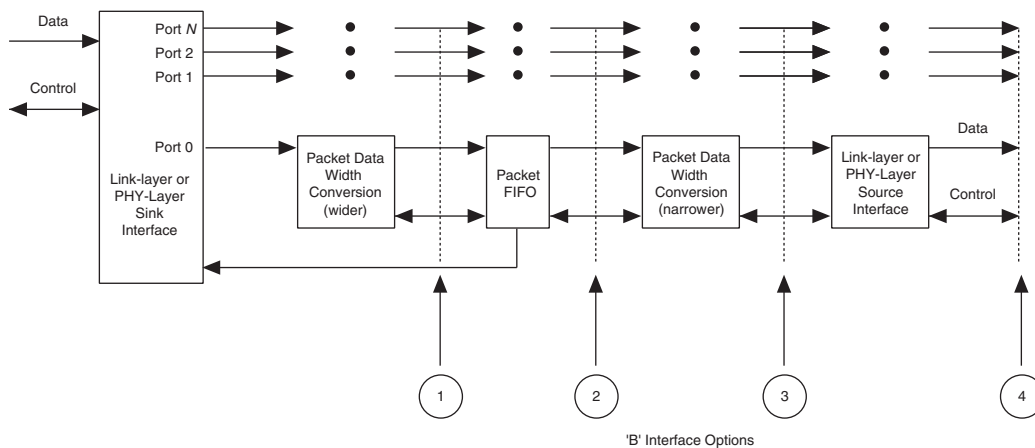
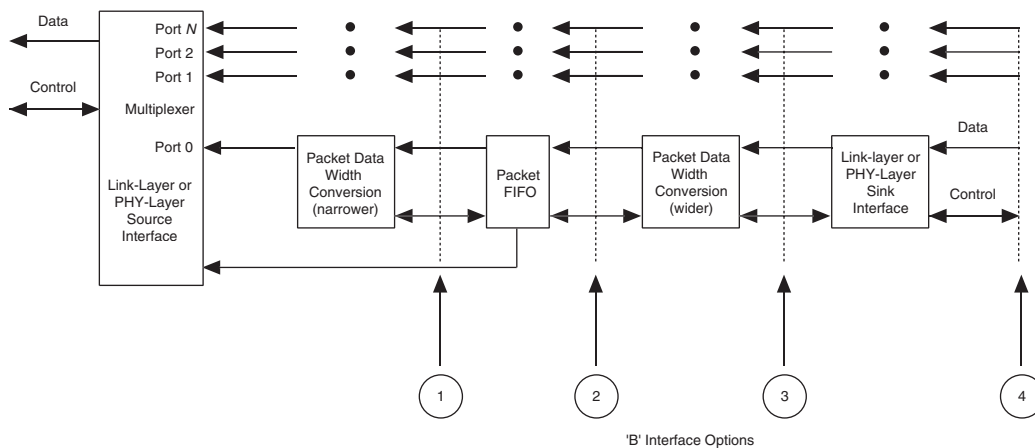

Figure 3-10. Source MegaCore Function Block Diagram



POS-PHY Interface

Each POS-PHY supports single and multi-PHY implementations. The POS-PHY interface interfaces to an internal multiplexer, which allows access to multiple/single internal packet FIFO buffers. Status information from the FIFO buffers is used to control the POS-PHY interface. The source interface provides polled or direct packet available modes.

Packet Data Width Conversion

Packet data width conversion provides conversion from a narrower to a wider data stream, and from a wider to a narrower data stream, if required (such as, 8-bit to 32- or 16-bit, or 32-bit to 8- or 16-bit, and so on).

Packet FIFO Buffer

The packet FIFO buffer has configurable width, depth, and fill level options. The FIFO buffer stores packet data in line with its associated packet flags (start of packet (SOP), end of packet (EOP), modulo (mod), and so on).

'B' Interface

The 'B' interface can be positioned at four different places, as follows:

1. After the first data width conversion—you provide a FIFO-like interface. The data width must be greater than or equal to the required POS-PHY bus width. Atlantic™ interfaces here can only be masters.
2. After the packet FIFO buffer—you must interface to the internal packet FIFO buffer at the data width of the FIFO buffer, which is greater than or equal to that of the required POS-PHY bus. Atlantic interfaces here can be master or a slave interfaces.
3. After the second data width conversion—this position provides an interface where the data width can be narrower than that supported by the FIFO buffer. For example, a 32-bit POS-PHY to or from an 8-bit POS-PHY. Atlantic interfaces here can be a master or a slave interfaces.
4. After a POS-PHY interface—where you can create a POS-PHY bridge. From a single compiler you can build a MPHY to multiple SPHY bridge, or an SPHY to SPHY bridge. You can create more complex solutions by instantiating more than one MegaCore function.

OpenCore Plus Time-Out Behavior

OpenCore Plus hardware evaluation supports the following two operation modes:

- Untethered—the design runs for a limited time.
- Tethered—requires a connection between your board and the host computer. If tethered mode is supported by all megafunctions in a design, the device can operate for a longer time or indefinitely.

All megafunctions in a device time out simultaneously when the most restrictive evaluation time is reached. If there is more than one megafunction in a design, a specific megafunction's time-out behavior may be masked by the time-out behavior of the other megafunctions.



For MegaCore functions, the untethered timeout is 1 hour; the tethered timeout value is indefinite.

Your design stops working after the hardware evaluation time expires and the following events occur:

- For the POS-PHY receive interface:
 - The sop_ina input goes low
 - The addr_outa output goes low
 - The dpav_outa output goes low
 - The ppav_outa output goes low
 - The spav_outa output goes low
 - The rd_outa output goes low
- For the POS-PHY transmit interface:
 - The wr_outA output goes low
 - The val_outA output goes low
 - The sx_outA output goes low
 - The sop_outA output goes low
 - The eop_outA output goes low
 - The err_outA output goes high
 - The data_outA output goes low



For more information on OpenCore Plus hardware evaluation, see [“OpenCore Plus Evaluation” on page 1–4](#) and [AN 320: OpenCore Plus Evaluation of Megafunctions](#).

Parameters

The function’s parameters, which can only be set in IP Toolbench (see [“Step 1: Parameterize” on page 2–5](#)), include the following settings:

- [Interface Settings](#)
- [Parity Settings](#)
- [FIFO Buffer Settings](#)
- [Address & Packet Available Settings](#)

Interface Settings

FIFO Buffer & Clock Selector Options

The following interface ‘B’ FIFO buffer and clock selector options are available:

- A Clock (No FIFO buffer)—only available if the ‘B’ interface is an Atlantic master, and the ‘B’ interface bus width \geq the ‘A’ interface bus width. The relevant ‘B’ interface does not use an internal FIFO buffer, and is clocked by the ‘A’ interface clock pin. This is recommended only if you connect ‘B’ interfaces directly to another MegaCore function with an Atlantic slave interface
- A Clock—the corresponding ‘B’ interface uses an internal single clock FIFO buffer, and is clocked by the A interface clock pin

- B Clock—the corresponding 'B' interface uses an internal dual clock FIFO buffer, and is clocked by the corresponding 'B' interface clock pin

The FIFO buffer width is the greater of the A bus width and the associated B bus width.

Common B Clock

With MPHY configurations there is more than one 'B' interface in the MegaCore function. Select this option to use a common clock and reset pins for all the 'B' interfaces that use the B clock option.

If you select this option, the 'B' interface clock and reset pins are labeled `b_clk` and `b_reset_n`.

Parity Settings

This section describes pass through mode and the `parerr` on error pin.

Pass Through Mode

In pass through mode any detected data parity errors on a sink interface are regenerated on the source interface, even when there is a bus width change.



If a parity error is detected on a sink interface port that has a wider data width than its corresponding source interface port, the parity error is generated on all output words that correspond to the input word with an error.

Table 3-2 shows the number of errors generated per input error.

Table 3-2. Number of Errors Generated

Data Width In	Data Width Out	Number of Errors Generated per Input Error
64	8	8
64	16	4
64	32	2
64	64	1
32	8	4
32	16	2
32	32	1
16	8	2
16	16	1
8	8	1

If you are using the parity bit and the parity does not match the data, the MegaCore function always detects the parity error.

For a source Atlantic interface, the `par` pin is an output that indicates the sink interface has received parity errors.

For a sink Atlantic interface, the `par` pin is an input that sees either a one or a zero depending on the incoming data's parity value.

If a parity error is detected on a sink interface port, which has a wider data width than its corresponding source interface port, the parity output is high on all output words that correspond to the input word with an error (see [Table 3-2](#)).

When a parity error is detected (as the data comes in), but the data width changes (increases), there are two options—pass through or error.

Pass through—the word that goes out, which contains the erroneous word and a good word, is flagged with an incorrect parity.

Error—the `par` signal functionality changes. It does not show parity, but goes high only when there is an error with the word, that is, it goes high to show where the error is.

ParErr On Error Pin

When you check this option, the `err` signal is created, which looks for parity errors in the entire packet. The `err` signal can go high at anytime, but is valid only at the end of the packet (in accordance with the POS-PHY specifications). A high indicates a parity error somewhere in the packet. A parity error detected on a sink interface is signalled by setting the `err` pin at the end of the affected packet on the source interface.

FIFO Buffer Settings

[Table 3-3](#) shows the effect of the FIFO buffer settings for POS-PHY level 3 interfaces.



All FIFO buffer parameters are shown in bytes.

Table 3-3. POS-PHY Level 3 FIFO Buffer Settings (Part 1 of 2)

Interface (Direction)	FIFO Threshold	FIFO Burst	FIFO Remote Burst
Link Transmit (Source)	When each FIFO buffer overflows the FIFO buffer threshold level, or contains a packet or packet fragment with an EOP, it triggers its not empty flag. The interface then tries to empty each of the FIFO buffers containing data, as soon as it detects the PHY transmit interface has indicated it has space. When operating in polled mode, this is indicated using the PTPA and STPA inputs. When operating in direct status mode, this is indicated using the DTPA inputs.	Indicates the maximum number of bytes the interface transfers in each FIFO buffer burst. In MPHY mode, at the end of each FIFO buffer burst the MegaCore function re-arbitrates for a new channel in a round-robin fashion. Set FIFO buffer burst \leq FIFO buffer threshold. Not applicable in SPHY mode.	Prevents the PHY transmit interface from overflowing. Must be compatible with the PHY transmit interface FIFO buffer burst setting. When the interface is in the process of transferring data and the PHY transmit interface indicates it is almost full, link transmit interface transfers up to FIFO buffer remote burst more bytes before stopping. When operating in polled mode, this is indicated using the PTPA and STPA inputs. When operating in direct status mode, this is indicated using the DTPA inputs.
Link Receive (Sink)	The interface indicates, by asserting low the RENB output, that it is not full when it has more than or equal to FIFO buffer threshold spaces for bytes in all of its FIFO buffers (1 FIFO buffer per channel). The interface indicates, by deasserting high the RENB output, that it is full when it has no more spaces for bytes in any of its FIFO buffers (1 FIFO buffer per channel).	This should be set to the minimum value allowed.	—

Table 3-3. POS-PHY Level 3 FIFO Buffer Settings (Part 2 of 2)

Interface (Direction)	FIFO Threshold	FIFO Burst	FIFO Remote Burst
PHY Transmit (Sink)	<p>When there is more than or equal to FIFO buffer threshold spaces for bytes in any of its FIFO buffers (1 FIFO buffer per channel), the interface indicates this on a per channel basis to the link transmit interface.</p> <p>When operating in polled mode, this is indicated by asserting PTPA and STPA outputs.</p> <p>When operating in direct status mode, this is indicated by asserting the DTPA outputs.</p>	<p>When there is less than FIFO buffer burst spaces for bytes in any of its FIFO buffers (1 FIFO buffer per channel), the interface indicates this on a per channel basis to the link transmit interface.</p> <p>When operating in polled mode, this is indicated by deasserting the PTPA and STPA outputs.</p> <p>When operating in direct status mode, this is indicated by deasserting the DTPA outputs.</p>	—
PHY Receive (Source)	<p>When each FIFO buffer fills to above the FIFO buffer threshold level, or contains a packet or packet fragment with an EOP, it triggers its not empty flag. The interface then tries to empty each of the FIFO buffers with data, as soon as it detects the link receive interface has asserted low the RENB input.</p>	<p>Indicates the maximum number of bytes the interface transfers in each FIFO buffer burst.</p> <p>In MPHY mode, at the end of each FIFO buffer burst the MegaCore function re-arbitrates for a new channel in a round-robin fashion.</p> <p>Set FIFO buffer burst \leq FIFO buffer threshold.</p> <p>In SPHY mode, this should be set to the minimum value allowed.</p>	—

Table 3-4 shows the effect of the FIFO buffer settings for POS-PHY level 2 interfaces.

Table 3-4. POS-PHY Level 2 FIFO Buffer Settings (Part 1 of 2)

Interface (Direction)	FIFO Threshold	FIFO Burst	FIFO Remote Burst
Link Transmit (Source)	<p>When each FIFO buffer fills to above the FIFO buffer threshold level, or contains a packet or packet fragment with an EOP, it triggers its not empty flag. The interface then tries to empty each of the FIFO buffers containing data, as soon as it detects the PHY transmit interface has indicated it has space.</p> <p>When operating in polled mode, this is detected using the PTPA and STPA inputs.</p> <p>When operating in direct status mode, this is detected using the DTPA inputs.</p>	<p>Indicates the maximum number of bytes the interface transfers in each FIFO buffer burst.</p> <p>In MPHY mode, at the end of each FIFO buffer burst the MegaCore function re-arbitrates for a new channel in a round-robin fashion.</p> <p>Set FIFO buffer burst \leq FIFO buffer threshold.</p> <p>Not applicable in SPHY mode.</p>	<p>When the interface is in the process of transferring data and the PHY transmit interface indicates it is almost full, the link transmit interface transfers up to FIFO buffer remote burst more bytes before stopping.</p> <p>When operating in polled mode, this is detected using the PTPA and STPA inputs.</p> <p>When operating in direct status mode, this is detected using the DTPA inputs.</p>
Link Receive (Sink)	<p>When there is more than or equal to FIFO buffer threshold spaces for bytes in any of its FIFO buffers (1 FIFO buffer per channel), the internal FIFO buffer full flag is deasserted. This allows the interface to start transferring data, as soon as it detects the PHY receive interface has indicated it has data.</p> <p>When operating in polled mode, this is detected using the PRPA input.</p> <p>When operating in direct status mode, this is detected using the DRPA inputs.</p>	<p>Indicates the maximum number of bytes the interface transfers in each FIFO buffer burst. When there is less than FIFO buffer burst spaces in the FIFO buffer, the internal FIFO buffer full flag is asserted.</p> <p>In MPHY mode, at the end of each FIFO buffer burst the MegaCore function re-arbitrates for a new channel in a round-robin fashion.</p> <p>Set FIFO buffer burst \leq FIFO buffer threshold.</p> <p>In SPHY mode, this should be set to the minimum value allowed.</p>	—

Table 3-4. POS-PHY Level 2 FIFO Buffer Settings (Part 2 of 2)

Interface (Direction)	FIFO Threshold	FIFO Burst	FIFO Remote Burst
PHY Transmit (Sink)	<p>When there is more than or equal to FIFO buffer threshold spaces for bytes in any of its FIFO buffers (1 FIFO buffer per channel), the interface indicates this on a per channel basis to the link transmit interface.</p> <p>When operating in polled mode, this is indicated by asserting PTPA and STPA outputs.</p> <p>When operating in direct status mode, this is indicated by asserting the DTPA outputs.</p>	<p>When there is less than FIFO buffer burst spaces for bytes in any of its FIFO buffers (1 FIFO buffer per channel) the interface indicates this on a per channel basis to the link transmit interface.</p> <p>When operating in polled mode, this is indicated by deasserting the PTPA output.</p> <p>When operating in direct status mode, this is indicated by deasserting the DTPA outputs.</p>	—
PHY Receive (Source)	<p>When there are more than FIFO buffer threshold bytes in any of its FIFO buffers (1 FIFO buffer per channel), the interface indicates this on a per channel basis to the link receive interface.</p> <p>When operating in polled mode, this is indicated by asserting the PRPA output.</p> <p>When operating in direct status mode, this is indicated by asserting the DRPA outputs.</p>	<p>When there are less than or equal to FIFO buffer burst bytes in any of its FIFO buffers (1 FIFO buffer per channel), the interface indicates this on a per channel basis to the link receive interface.</p> <p>When operating in polled mode, this is indicated by deasserting the PRPA output.</p> <p>When operating in direct status mode, this is indicated by deasserting the DRPA outputs.</p>	—

Atlantic Interface FIFO Buffer Settings

For the Atlantic master source, the *dav* signal is an input. The slave indicates to the master that it has space by asserting *dav*. The master then tries to fill the slave FIFO buffer. [Figure 3-11](#) shows the behavior of the *dav* signal. FIFO burst is not applicable. FIFO buffer remote burst—when the slave deasserts *dav*, the master can transfer up to FIFO buffer remote burst more bytes of data before stopping.

Figure 3-11. Behavior of the *dav* Signal as an Input to the Atlantic Master Source *(Note 1)*

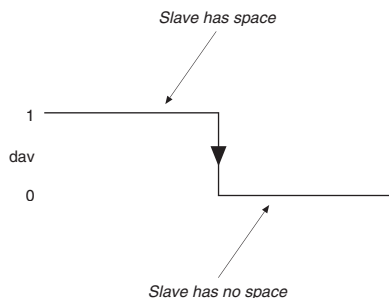

Note to Figure 3-11:

(1) The slave asserts *dav* high for two reasons: it has passed its threshold, or an EOP has occurred.

For the Atlantic master sink, the `dav` signal is an input. The slave indicates to the master that it has data by asserting `dav`. The master then tries to empty the slave FIFO buffer. [Figure 3-12](#) shows the behavior of the `dav` signal. FIFO buffer burst is not applicable. FIFO buffer remote burst is not applicable.

Figure 3-12. Behavior of the `dav` Signal as an Input to the Atlantic Master Sink *(Note 1)*

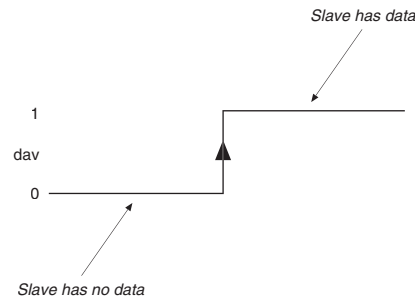

Note to Figure 3-12:

(1) The slave asserts `dav` high for two reasons: it has passed its threshold, or an EOP has occurred.

For the Atlantic slave sink, the `dav` signal is an output. The `dav` signal high indicates that there is space for more data. When the FIFO buffer is below full threshold, `dav` is high. When the FIFO buffer is filling, `dav` remains high until the FIFO buffer reaches burst threshold. When the FIFO buffer is emptying, `dav` remains low until the FIFO buffer reaches full threshold. [Figure 3-13](#) shows the behavior of the `dav` signal. FIFO buffer remote burst is not applicable.

Figure 3-13. Behavior of the `dav` Signal—Atlantic Slave Sink

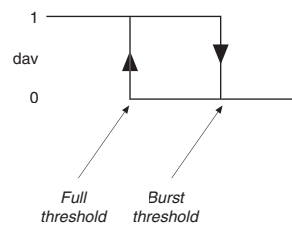

For the Atlantic slave source, the `dav` signal is an output. When `dav` is high, there is data to send. When the FIFO buffer is above the empty threshold, `dav` is high. When the FIFO buffer is filling, `dav` remains low until the FIFO buffer reaches empty threshold. When the FIFO buffer is emptying, `dav` remains high until the FIFO buffer reaches burst threshold. [Figure 3-14](#) shows the behavior of the `dav` signal. FIFO buffer remote burst is not applicable.

Figure 3-14. Behavior of the `dav` Signal—Atlantic Slave Source

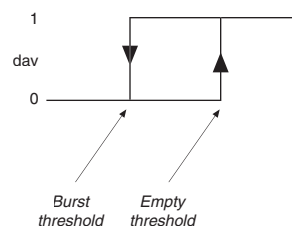

FIFO Buffer Size

The FIFO buffer size is automatically set to be as wide as the widest of the input and the output port.

Each word in the FIFO buffer can only contain at most one packet. Where the FIFO buffer width is N bytes, packets of 1 to N bytes in length occupy 1 FIFO buffer word. So, a FIFO buffer of (M words \times N bytes) can only hold M packets with a length of 1 to N bytes.

Address & Packet Available Settings

The Atlantic interface always operates in direct (no addressing) mode.

POS-PHY Level 3 Interfaces

The POS-PHY level 3 interfaces can be multi- or single-channel. Table 3-5 shows the multi-channel packet available mode options.

Table 3-5. Multi-Channel Packet Available Mode Options (POS-PHY Level 3)

Option	Description
Direct	In the POS-PHY transmit direction the MegaCore function uses one <code>dtpa</code> pin per supported channel. In the POS-PHY receive direction the MegaCore function uses <code>renb</code> and <code>rval</code> to support all channels.
Polled	In the POS-PHY transmit direction the MegaCore function uses <code>tadr</code> , <code>ptpa</code> , and <code>stpa</code> , to support all channels.
Polled (Ignore <code>stpa</code>)	In the POS-PHY transmit direction the MegaCore function uses <code>tadr</code> and <code>ptpa</code> to support all channels. For compatibility with some POS-PHY interfaces that do not support the functionality of the <code>stpa</code> pin, the <code>stpa</code> signal is ignored and removed from the MegaCore function.

Table 3-6 shows the multi-channel packet available mode options.



'B' interfaces always operate in direct mode.

Table 3-6. Single-Channel Packet Available Mode Options (POS-PHY Level 3)

Option	Description
Direct	In the POS-PHY transmit direction the MegaCore function uses one <code>dtpa</code> pin, and uses a <code>tsx</code> pin. In the POS-PHY receive direction the MegaCore function uses <code>renb</code> and <code>rval</code> , and uses an <code>rsx</code> pin.
Direct (No Addressing)	In the POS-PHY transmit direction the MegaCore function uses one <code>dtpa</code> pin, and does not use a <code>tsx</code> pin. In the POS-PHY receive direction the MegaCore function uses <code>renb</code> and <code>rval</code> , and does not use an <code>rsx</code> pin.

POS-PHY Level 2 Interfaces

The POS-PHY level 2 interfaces can be multi- or single-channel. Table 3-7 shows the multi-channel packet available mode options.

Table 3-7. Multi- & Single-Channel Packet Available Mode Options (POS-PHY Level 2)

Option	Description
Direct	In the POS-PHY transmit direction the MegaCore function uses one <code>dtpa</code> pin per supported channel. In the POS-PHY receive direction the MegaCore function uses one <code>drpa</code> pin per supported channel.
Polled	In the POS-PHY transmit direction the MegaCore function uses <code>tadr</code> , <code>ptpa</code> , and <code>stpa</code> to support all channels. In the POS-PHY receive direction the MegaCore function uses <code>radr</code> and <code>prpa</code> to support all channels.
Polled (Ignore <code>stpa</code>)	In the POS-PHY transmit direction the MegaCore function uses <code>tadr</code> and <code>ptpa</code> pins to support all channels. The <code>stpa</code> signal is removed from the MegaCore function.

Direct (No Addressing) mode does not include address matching or bus tri-stating (currently not supported).

Base Address

Base address is only supported in POS-PHY level 2 mode. It configures the base address of the POS-PHY port. For a single channel interface ('A' or 'B'), the interface responds to only the configured base address. For a multi-channel interface ('A' only), the interface responds to addresses between base address and base address + number of 'B' interfaces.

SX Always

SX always is only valid for POS-PHY level 3 link transmit (multi-channel) or PHY receive (source) interfaces. You can set the SX output behavior to one of the following conditions:

- Normal—generates an SX cycle only when changing channels
- Always—an SX cycle is generated for every burst and at the end of packets



For POS-PHY level 3 sink interfaces, the MegaCore function supports either behavior transparently.

Interface Signals

The following section describes the interface signals for the MegaCore functions. [Figure 3-15](#) shows the input/output specification.

Figure 3-15. Input/Output Specification

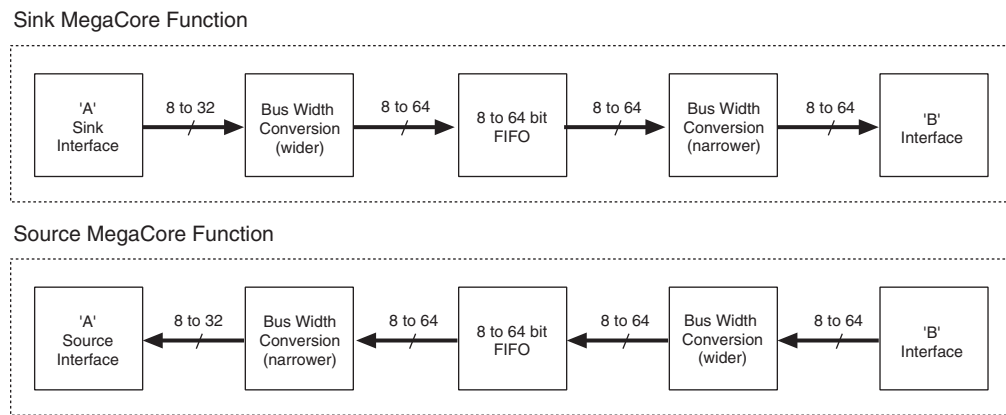

Global Interface

Table 3-8 describes the global interface signals.

Table 3-8. Global Interface Description (Note 1)

Signal	Direction	Description
<code>treset_n</code>	Input	Asynchronous reset for all flip-flops on the POS-PHY source <code>tfclk</code> clock domain, active low. Can be asserted asynchronously, but must be deasserted synchronously to <code>tfclk</code> .
<code>rreset_n</code>	Input	Asynchronous reset for all flip-flops on the POS-PHY receive <code>rfclk</code> clock domain, active low. Can be asserted asynchronously, but must be deasserted synchronously to <code>rfclk</code> .
<code>reset_n</code>	Input	Asynchronous reset for the Atlantic interface, active low. Can be asserted asynchronously, but must be deasserted synchronously to <code>clk</code> .
<code>clk</code>	Input	Clock, rising-edge active. The Atlantic interface uses single-edge clocking. All signals are synchronous to <code>clk</code> , and master and slave are in the same clock domain. (1)

Note to Table 3-8:

(1) POS-PHY clock signals are described in the relevant interface tables.

The 'A' interface and each 'B' interface have independent resets, which are provided to allow you to assert the reset asynchronously to its clock domain. They are not intended to provide individual channel resets. If one channel needs a reset, all channels must be reset. Deasserting the resets must be done synchronously to its clock domain.

Additionally, IP Toolbench can connect the independent resets and clocks to a common reset and clock (see "Common B Clock" on page 3-8).

'A' interface signals are prefixed by `a_`; 'B' interface signals are prefixed by `b1_`, `b2_`, and so on.

POS-PHY Level 3 Interface

The interface direction is shown as either link to PHY, or PHY to link.

For a POS-PHY level 3 link-layer MegaCore function, the following rules apply:

- Link to PHY results in an output port on the MegaCore function.
- PHY to link results in an input port on the MegaCore function.

For a POS-PHY level 3 PHY-layer MegaCore function, the following rules apply:

- Link to PHY results in an input port on the MegaCore function.
- PHY to link results in an output port on the MegaCore function.



'A' interface signals are prefixed by a_; 'B' interface signals are prefixed by b1_, b2_, and so on.

Table 3-9 describes the POS-PHY level 3 transmit interface.

Table 3-9. POS-PHY Level 3 Transmit Interface (Part 1 of 2)

Signal	Direction	Description
tfc1k	Input	Transmit FIFO buffer write clock. <code>tfc1k</code> synchronizes data transfer transactions between the link-layer device and the PHY-layer device. <code>tfc1k</code> can cycle at a rate up to 104 MHz.
tdat [31:0]	Link to PHY	Transmit packet data bus. This bus carries the packet octets that are written to the selected transmit FIFO buffer. The <code>tdat</code> bus is valid only when <code>tenb</code> is asserted. The data must be transmitted in big-endian order on <code>tdat</code> . When an 8-bit interface is used, only <code>tdat [7:0]</code> is supported.
tsop	Link to PHY	Transmit start of packet signal. <code>tsop</code> delineates the packet boundaries on the <code>tdat</code> bus. When <code>tsop</code> is high, the start of the packet is present on the <code>tdat</code> bus. <code>tsop</code> is required to be present at the beginning of every packet and is valid only when <code>tenb</code> is asserted.
teop	Link to PHY	Transmit end of packet signal. <code>teop</code> delineates the packet boundaries on the <code>tdat</code> bus. When <code>teop</code> is high, the end of the packet is present on the <code>tdat</code> bus. <code>tmod</code> indicates the number of valid bytes the last double-word is composed of, when <code>teop</code> is asserted. <code>teop</code> is required to be present at the end of every packet and is valid only when <code>tenb</code> is asserted.
terr	Link to PHY	Transmit error indicator signal. <code>terr</code> indicates that the current packet should be aborted. When <code>terr</code> is set high, the current packet is aborted. <code>terr</code> should only be asserted when <code>teop</code> is asserted.
tprty	Link to PHY	Transmit bus parity signal. The transmit parity signal indicates the parity calculated over the <code>tdat</code> bus. <code>tprty</code> is valid only when <code>tenb</code> is asserted. When <code>tprty</code> is supported, the PHY-layer device must support both even and odd parity. The PHY-layer device must report any parity error to higher layers, but does not interfere with the transferred data.
tmod [1:0]	Link to PHY	Transmit word modulo. <code>tmod</code> indicates the number of valid data bytes in <code>tdat</code> . The <code>tmod</code> bus is normally zero, except during the last double-word transfer of a packet on <code>tdat</code> . When <code>teop</code> is asserted, the number of valid packet data bytes on <code>tdat</code> is specified by <code>tmod</code> . When <code>tmod [1:0] = '00'</code> , <code>tdat [31:0]</code> is valid. When <code>tmod [1:0] = '01'</code> <code>tdat [31:8]</code> is valid. When <code>tmod [1:0] = '10'</code> <code>tdat [31:16]</code> is valid. When <code>tmod [1:0] = '11'</code> <code>tdat [31:24]</code> is valid. When <code>tmod [1:0]</code> should only be asserted when <code>teop</code> is asserted.

Table 3-9. POS-PHY Level 3 Transmit Interface (Part 2 of 2)

Signal	Direction	Description
tenb	Link to PHY	Transmit write enable. tenb controls the flow of data to the transmit FIFO buffers. When tenb is high, tdat, tmod, tsop, teop and terr are invalid and are ignored by the PHY-layer. The tsx signal is valid and is processed by the PHY when tenb is high. When tenb is low, tdat, tmod, tsop, teop and terr are valid and are processed by the PHY-layer. Also, the tsx signal is ignored by the PHY-layer, when tenb is low. If you choose Atlantic master for the 'B' interface, the tenb signal is combinational.
tsx	Link to PHY	Transmit start of transfer signal. tsx indicates when the in-band port address is present on the tdat bus. When tsx is high and tenb is high, the value of tdat [7:0] is the address of the transmit FIFO buffer to be selected. Subsequent data transfers on the tdat bus fill the FIFO buffer specified by this in-band address. For single-port PHY devices, the tsx signal is optional, because the PHY device ignores in-band addresses when tenb is high. tsx is valid only when tenb is not asserted.
dtpa []	PHY to link Byte-level mode	Direct transmit packet available. dtpa provides status indication of the corresponding port in the PHY device. dtpa asserts high when a predefined (user programmable) minimum number of bytes is available in the transmit FIFO buffer. dtpa high does not indicate that the transmit FIFO buffer is full. When dtpa transitions low, it indicates that its transmit FIFO buffer is full or nearly full (user programmable). dtpa is required if byte-level transfer mode is supported. dtpa is updated on the rising edge of tfclk.
tadr [] (1)	Link to PHY	Transmit address. tadr is used with ptpa to poll the transmit FIFO buffer's packet available status. When tadr is sampled on the rising edge of tfclk by the PHY, the polled packet available indication ptpa is updated with the status of the port specified by the tadr address on the following rising edge of tfclk.
stpa (2)	PHY to link	Selected PHY transmit packet available. stpa transitions high, when fifo_threshold words are available in the transmit FIFO buffer specified by the in-band address on tdat. When high, stpa indicates that the transmit FIFO buffer is not full. When stpa transitions low, it indicates that the transmit FIFO buffer is full or near full (user programmable). stpa always provides status indication for the selected port of the PHY device to avoid FIFO buffer overflows while polling is performed. The port which stpa reports is updated on the following rising clock edge of tfclk after the PHY address on tdat is sampled by the PHY device. stpa is required if byte-level transfer mode is supported. stpa is updated on the rising edge of tfclk.
ptpa (1)	PHY to link	Polled PHY transmit packet available. ptpa transitions high when fifo_threshold words are available in the polled transmit FIFO buffer. When high, ptpa indicates that the transmit FIFO buffer is not full. When ptpa transitions low, it indicates that the transmit FIFO buffer is full or near full (user programmable). ptpa allows the polling of the PHY selected by the tadr address bus. The port that ptpa reports is updated on the following rising edge of tfclk, after the PHY address on tadr is sampled by the PHY device. ptpa is required if packet-level transfer mode is supported. ptpa is updated on the rising edge of tfclk.

Notes to Table 3-9:

- (1) Packet-level mode only
- (2) Byte-level mode only

Table 3-10 describes the POS-PHY level 3 receive interface.

 These signals are compliant with the POS-PHY Level 3 Specification, Issue 4, June 2000.

Table 3-10. POS-PHY Level 3 Receive Interface (Part 1 of 2)

Signal	Direction	Description
<code>rfclk</code>	Input	Receive FIFO buffer write clock. <code>rfclk</code> is used to synchronize data-transfer transactions between the link-layer device and the PHY-layer device. <code>rfclk</code> can cycle at a rate up to 104 MHz.
<code>rdat [31:7:0]</code>	PHY to link	Receive packet data bus. The <code>rdat</code> bus carries the packet octets that are read from the receive FIFO buffer. <code>rdat</code> is valid only when <code>rval</code> is asserted. Data must be received in big-endian order on <code>rdat</code> . When an 8-bit interface is used, only <code>rdat [7:0]</code> is supported.
<code>rsop</code>	PHY to link	Receive start of packet. <code>rsop</code> delineates the packet boundaries on the <code>rdat</code> bus. When <code>rsop</code> is high, the start of the packet is present on the <code>rdat</code> bus. <code>rsop</code> must be present at the beginning of every packet and is valid only when <code>rval</code> is asserted.
<code>reop</code>	PHY to link	Receive end of packet. <code>reop</code> delineates the packet boundaries on the <code>rdat</code> bus. When <code>reop</code> is high, the end of the packet is present on the <code>rdat</code> bus. <code>rmod</code> indicates the number of valid bytes the last double-word is composed of, when <code>reop</code> is asserted. <code>reop</code> is required to be present at the end of every packet and is valid only when <code>rval</code> is asserted.
<code>rerr</code>	PHY to link	Receive error indicator. <code>rerr</code> is used to indicate that the current packet is aborted and should be discarded. <code>rerr</code> should only be asserted when <code>reop</code> is asserted. Conditions that can cause <code>rerr</code> to be set can be, but are not limited to, FIFO buffer overflow, abort-sequence detection, missing SOP, missing EOP, and parity errors. <code>rerr</code> is asserted at its input. <code>rerr</code> is valid only when <code>rval</code> is asserted.
<code>rmod [1:0]</code>	PHY to link	Receive word modulo signal. <code>rmod</code> indicates the number of valid bytes of data in <code>rdat</code> . The <code>rmod</code> bus should always be all zero, except during the last double-word transfer of a packet on <code>rdat</code> . When <code>reop</code> is asserted, the number of valid packet data bytes on <code>rdat</code> is specified by <code>rmod</code> When <code>rmod [1:0] = '00'</code> <code>rdat [31:0]</code> is valid. When <code>rmod [1:0] = '01'</code> <code>rdat [31:8]</code> is valid. When <code>rmod [1:0] = '10'</code> <code>rdat [31:16]</code> is valid. When <code>rmod [1:0] = '11'</code> <code>rdat [31:24]</code> is valid <code>rmod</code> is valid only when <code>rval</code> is asserted.
<code>rprty</code>	PHY to link	Receive parity signal. <code>rprty</code> indicates the parity calculated over the <code>rdat</code> bus. When <code>rprty</code> is supported, the PHY-layer device must support both odd and even parity.
<code>renb</code>	Link to PHY	Receive read enable (see Figure 3-16). <code>renb</code> controls the flow of data from the receive FIFO buffers. During data transfer, <code>rval</code> must be monitored, as it indicates if <code>rdat</code> , <code>rprty</code> , <code>rmod</code> , <code>rsop</code> , <code>reop</code> , <code>rsx</code> , and <code>rerr</code> are valid. The system can deassert <code>renb</code> at anytime, if it is unable to accept data from the PHY device. When <code>renb</code> is sampled low by the PHY device, a read is performed from the receive FIFO buffer. <code>rdat</code> , <code>rprty</code> , <code>rmod</code> , <code>rsop</code> , <code>reop</code> , <code>rerr</code> , <code>rsx</code> , and <code>rval</code> are updated on the following rising edge of <code>rfclk</code> . When <code>renb</code> is sampled low by the PHY device, a read is not performed and <code>rdat</code> , <code>rprty</code> , <code>rmod</code> , <code>rsop</code> , <code>reop</code> , <code>rerr</code> , <code>rsx</code> , and <code>rval</code> are not updated on the following rising edge of <code>rfclk</code> .

Table 3-10. POS-PHY Level 3 Receive Interface (Part 2 of 2)

Signal	Direction	Description
rval	PHY to link	<p>Receive data valid. <code>rval</code> indicates the validity of the receive data signals. <code>rval</code> transitions low when a receive FIFO buffer is empty or at the end of a packet. When <code>rval</code> is high, <code>rdat</code>, <code>rprty</code>, <code>rmod</code>, <code>rsop</code>, <code>reop</code>, and <code>rerr</code> are valid. When <code>rval</code> is low, the <code>rdat</code>, <code>rprty</code>, <code>rmod</code>, <code>rsop</code>, <code>reop</code>, and <code>rerr</code> signals are invalid and must be disregarded.</p> <p>The <code>rsx</code> signal is valid when <code>rval</code> is low.</p>
rsx	PHY to link	<p>Receive start of transfer. <code>rsx</code> indicates when the in-band port address is present on the <code>rdat</code> bus. When <code>rsx</code> is high and <code>rval</code> is low, the value of <code>rdat[7:0]</code> is the address of the receive FIFO buffer to be selected by the PHY. Subsequent data transfers on the <code>rdat</code> bus are from the FIFO buffer specified by this in-band address. For single-port devices, the <code>rsx</code> signal is optional, as the device does not need to generate in-band addresses. <code>rsx</code> is valid only when <code>rval</code> is not asserted.</p> <p>In normal conditions <code>rsx</code> indicates a change of address. If the enable signal goes inactive as the core decides to select the address, you can have <code>rsx</code> going high while enable is deasserted. When enable gets reasserted, the core may reassert <code>rsx</code> with a different address selected. For example, when the core decides to reselect the same address just before it is asked to go inactive. By default the core reselects the same address if data is still available (even if less than a burst). When enable gets de-asserted, the core checks all possible addresses and if another address reaches the threshold, it selects the new address instead.</p> <p>Although it does not violate any POS-PHY protocol, some devices may select the address on the first <code>rsx</code> and not reselect the address on the second <code>rsx</code>.</p> <p>To avoid this issue use the fixed burst size. For fixed burst sizes, the core waits at the end of a packet to ensure the presence of data. If no other port has data, the core reselects the current one after a short pause. Thus the <code>rsx</code> signal gets asserted when enable goes high (inactive). The <code>rsx</code> signal stays high until the enable goes active again but the address does not change.</p>

Figure 3-16 shows the `renb` signal behavior.

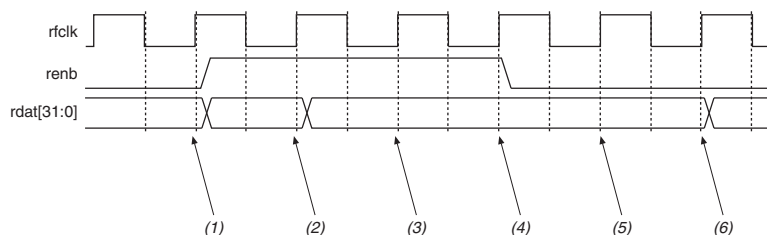
Figure 3-16. The renb Signal Behavior**Notes to Figure 3-16:**

- (1) The `renb` signal is sampled low—another read may take place.
- (2) The `renb` signal is sampled high—all signals must stabilize and remain unchanged on the following `rclk` rising edge.
- (3) The `renb` signal was sampled high on the previous `rclk` rising edge—all signals must remain unchanged. The MegaCore function uses this time to sample data from `rdat[31:0]`. The POS-PHY specification allows data to be sampled anytime between 3 and 6 (3, 4, 5, or 6 are all valid).
- (4) The `renb` signal remains high—all signals must remain unchanged.
- (5) The `renb` signal is sampled low, therefore data may change on the next `rclk` rising edge.
- (6) Data on `rdat[31:0]` and all other signals may change.

According to the POS-PHY specifications, when `renb` is sampled low by the PHY device, a read is performed from the receive FIFO buffer and the `rdat[31:0]` signals are updated on the following rising edge of `rclk`.

POS-PHY Level 2 Interface

The interface direction is shown as either link to PHY, or PHY to link.

For a POS-PHY level 2 link-layer MegaCore function, the following applies:

- Link to PHY results in an output port on the MegaCore function.
- PHY to link results in an input port on the MegaCore function.

For a POS-PHY level 2 PHY-layer MegaCore function, the following applies:

- Link to PHY results in an input port on the MegaCore function.
- PHY to link results in an output port on the MegaCore function.



'A' interface signals are prefixed by `a_`; 'B' interface signals are prefixed by `b1_`, `b2_`, and so on.

Table 3-11 describes the POS-PHY level 2 transmit interface.

Table 3-11. POS-PHY Level 2 Transmit Interface (Part 1 of 2)

Signal	Direction	Description
<code>t_{dat} [15/7:0]</code> (1)	Link to PHY	Transmit packet data bus. <code>t_{dat}</code> carries the packet octets that are written to the selected transmit FIFO buffer. <code>t_{dat}</code> is valid only when <code>t_{enb}</code> is simultaneously asserted. Data must be transmitted in big-endian order. Given the previously defined data structure, bits are transmitted in the following order: 15, 14 ... 8, 7, 6 ... 1, 0.
<code>t_{prty}</code>	Link to PHY	Transmit bus parity. <code>t_{prty}</code> indicates the parity calculated over the whole <code>t_{dat}</code> bus. When <code>t_{prty}</code> is supported, the PHY-layer device is required to support both even and odd parity. The PHY-layer device reports any parity error to higher layers but does not interfere with the transferred data. <code>t_{prty}</code> is valid only when <code>t_{enb}</code> is asserted.
<code>t_{mod}</code> (2)	Link to PHY	The transmit word modulo. <code>t_{mod}</code> indicates the size of the current word. <code>t_{mod}</code> should always be low, except during the last word transfer of a packet (when <code>t_{eop}</code> is asserted). During a packet transfer every word must be complete except the last word, which can comprise 1 or 2 bytes. When set high, <code>t_{mod}</code> indicates a 1-byte word (present on MSBs, LSBs are discarded); when set low, <code>t_{mod}</code> indicates a 2-byte word.
<code>t_{sop}</code>	Link to PHY	Transmit start of packet. <code>t_{sop}</code> indicates the first word of a packet. <code>t_{sop}</code> must be present at the beginning of every packet and is valid only when <code>t_{enb}</code> is asserted.
<code>t_{eop}</code>	Link to PHY	Active-high transmit end of packet. <code>t_{eop}</code> marks the end of a packet on the <code>t_{dat}</code> bus. When <code>t_{eop}</code> is high, the last word of the packet is present on the <code>t_{dat}</code> stream and <code>t_{mod}</code> indicates how many bytes this last word is composed of. <code>t_{sop}</code> must not be high when <code>t_{eop}</code> is high. <code>t_{eop}</code> provides support for one or two bytes packets, as indicated by the value of <code>t_{mod}</code> .
<code>t_{err}</code>	Link to PHY	The transmit error indicator. <code>t_{err}</code> must only be asserted during the last word transfer of a packet.
<code>t_{enb}</code>	Link to PHY	Transmit MPHY write enable. <code>t_{enb}</code> is an active low input and is used along with the <code>t_{adr}</code> inputs to initiate writes to the transmit FIFO buffers. POS-PHY supports byte-level and packet-level transfer. Packet-level transfer operates with a selection phase when <code>t_{enb}</code> is deasserted and a transfer phase when <code>t_{enb}</code> is asserted. While <code>t_{enb}</code> is asserted, <code>t_{adr}</code> is used for polling <code>t_{tpa}</code> . Byte-level transfer works on a cycle basis. When <code>t_{enb}</code> is asserted data is transferred to the selected PHY. Nothing happens when <code>t_{enb}</code> is deasserted. Polling is not available in byte-level transfer mode, and direct packet availability is provided by <code>t_{tpa} [x]</code> .
<code>t_{adr} [4:0]</code>	Link to PHY	Transmit PHY address bus. The <code>t_{adr}</code> bus is used to select the FIFO buffer (and hence the port) that is written to using the <code>t_{enb}</code> signal, and the FIFO buffer whose packet-available signal is visible on the PTPA output when polling. Address <code>1Fh</code> is the null-PHY address and must not be identified to any port on the POS-PHY bus.
<code>t_{tpa}</code> (3)	PHY to link	Selected-PHY transmit packet available signal. <code>t_{tpa}</code> transitions high when <code>fifo_threshold</code> words are available in the selected transmit FIFO buffer (the one data is written into). When high, <code>t_{tpa}</code> indicates that the transmit FIFO buffer is not full. When <code>t_{tpa}</code> transitions low, it indicates that the transmit FIFO buffer has reached <code>fifo_threshold</code> words. <code>t_{tpa}</code> always provides status indication for the selected PHY to avoid FIFO buffer overflows while polling is performed. The PHY-layer device tri-states <code>t_{tpa}</code> when <code>t_{enb}</code> is deasserted. <code>t_{tpa}</code> is also tri-stated when either the null-PHY address (<code>1Fh</code>), or an address not matching the PHY-layer device address, is presented on the <code>t_{adr}</code> signals when <code>t_{enb}</code> is sampled high (has been deasserted during the previous clock cycle).

Table 3–11. POS-PHY Level 2 Transmit Interface (Part 2 of 2)

Signal	Direction	Description
<code>ptpa</code> (3)	PHY to link	Polled-PHY transmit packet available signal. <code>ptpa</code> transitions high when <code>fifo_threshold</code> words is available in the polled transmit FIFO buffer. When high, <code>ptpa</code> indicates that the transmit FIFO buffer is not full. When <code>ptpa</code> transitions low, it indicates that the transmit FIFO buffer has reached <code>fifo_threshold</code> words. PTPA allows to poll the PHY address selected by <code>tadr</code> when <code>tenb</code> is asserted. <code>ptpa</code> is driven by a PHY-layer device when its address is polled on <code>tadr</code> . A PHY-layer device tri-states <code>ptpa</code> when either the null-PHY address (0x1F) or an address not matching available PHY-layer devices is provided on <code>tadr</code> .
<code>dtpa[x]</code> (4)	PHY to link	Direct transmit packet available. <code>dtpa[x]</code> provides direct status indication for the corresponding port (referred to by the index “x”). <code>dtpa[x]</code> transitions high when <code>fifo_threshold</code> words are available in the transmit FIFO buffer. When high, <code>dtpa[x]</code> indicates that the transmit FIFO buffer is not full. When <code>dtpa[x]</code> transitions low, it indicates that the transmit FIFO buffer has reached <code>fifo_threshold</code> words.
<code>tfclk</code>	Link to PHY	Transmit FIFO buffer write clock. <code>tfclk</code> is used to synchronize data transfer transactions from the link-layer device to the PHY-layer device. <code>tfclk</code> can cycle at any rate from 25 MHz up to 50 MHz.

Notes to Table 3–11:

- (1) The 8-bit mode is an Altera extension to the POS-PHY Level 2 specification.
- (2) Not present in 8-bit mode.
- (3) Packet-level mode only.
- (4) Byte-level mode only.

Table 3–12 describes the POS-PHY level 2 receive interface.



All these signals are compliant with the POS-PHY Level 2 Specification, Issue 5, December 1998.

Table 3–12. POS-PHY Level 2 Receive Interface (Part 1 of 3)

Signal	Direction	Description
<code>rdat[15/7:0]</code> (1)	PHY to link	Receive packet data bus. The <code>rdat</code> bus carries the packet octets that are read from the selected receive FIFO buffer. <code>rdat</code> is valid only when <code>renb</code> is simultaneously asserted and a valid PHY-layer device has been selected via the <code>radr</code> signals. Data must be received in big-endian order. Given the defined data structure, bits are received in the following order: 15, 14 ... 8, 7, 6 ... 1, 0. The PHY-layer device tri-states <code>rdat</code> when <code>renb</code> is high. <code>rdat</code> is also tri-stated when either the null-PHY address (1Fh) or an address not matching the PHY-layer device address is presented on the <code>radr</code> signals when <code>renb</code> is sampled high (has been deasserted during the previous clock cycle).
<code>rprty</code>	PHY to link	Receive parity signal. <code>rprty</code> signal indicates the parity of the <code>rdat</code> bus. When <code>rprty</code> is supported, the PHY-layer device must support both odd and even parity. The PHY-layer device tri-states <code>rprty</code> when <code>renb</code> is high. <code>rprty</code> is also tri-stated when either the null-PHY address (1Fh), or an address not matching the PHY-layer device address, is presented on the <code>radr</code> signals when <code>renb</code> is sampled high (has been deasserted during the previous clock cycle).

Table 3-12. POS-PHY Level 2 Receive Interface (Part 2 of 3)

Signal	Direction	Description
<code>rmod</code> (2)	PHY to link	The receive word modulo signal. <code>rmod</code> indicates the size of the current word. <code>rmod</code> is only used during the last word transfer of a packet, when <code>reop</code> is asserted. During a packet transfer every word must be complete except the last word, which can be composed of 1 or 2 bytes. <code>rmod</code> set high indicates a 1-byte word (present on MSBs, LSBs are discarded); <code>rmod</code> set low indicates a 2-byte word. The PHY-layer device tri-states <code>rmod</code> when <code>renb</code> is high. <code>rmod</code> is also tri-stated when either the null-PHY address (1Fh), or an address not matching the PHY-layer device address, is presented on the <code>radr</code> signals when <code>renb</code> is sampled high (has been deasserted during the previous clock cycle).
<code>rsop</code>	PHY to link	Receive start of packet signal. <code>rsop</code> marks the first word of a packet transfer. The PHY-layer device must assert <code>rsop</code> for every packet. The PHY-layer device tri-states <code>rsop</code> when <code>renb</code> is high. <code>rsop</code> is also tri-stated when either the null-PHY address (1Fh), or an address not matching the PHY-layer device address, is presented on the <code>radr</code> signals when <code>renb</code> is sampled high (has been deasserted during the previous clock cycle).
<code>reop</code>	PHY to link	The receive end of packet signal. <code>reop</code> marks the end of packet on the <code>rdat</code> bus. During this same cycle <code>rmod</code> is used to indicate if the last word has 1 or 2 bytes. <code>rsop</code> must not be high when <code>reop</code> is high. This provides support for one or two bytes packets, as indicated by the value of <code>rmod</code> . The PHY-layer device tri-states <code>reop</code> when <code>renb</code> is high. <code>reop</code> is also tri-stated when either the null-PHY address (0x1F), or an address not matching the PHY-layer device address, is presented on the <code>radr</code> signals when <code>renb</code> is sampled high (has been deasserted during the previous clock cycle).
<code>rerr</code>	PHY to link	The receive error indicator signal. <code>rerr</code> is used to indicate that the current packet is aborted and should be discarded. <code>rerr</code> can only be asserted during the last word transfer of a packet. Conditions that can cause <code>rerr</code> to be set may be, but are not limited to, FIFO buffer overflow, abort-sequence detection, missing SOP, missing EOP, and parity errors. The PHY-layer device tri-states <code>rerr</code> when <code>renb</code> is high. <code>rerr</code> is asserted at its input. <code>rerr</code> is valid only when <code>rval</code> is asserted. <code>rerr</code> is also tri-stated when either the null-PHY address (1Fh), or an address not matching the PHY-layer device address, is presented on the <code>radr</code> signals when <code>renb</code> is sampled high (has been deasserted during the previous clock cycle).
<code>renb</code>	Link to PHY	Receive multi-PHY read enable signal. <code>renb</code> is used to initiate reads from the receive FIFO buffers. The POS-PHY specification supports both byte-level and packet- <code>renb</code> transfer. Packet-level transfer operates with a selection phase when <code>renb</code> is deasserted and a transfer phase when <code>renb</code> is asserted. While <code>renb</code> is asserted, <code>radr</code> is used for polling <code>prpa</code> . Byte-level transfer works on a cycle basis. When <code>renb</code> is asserted, data is transferred from the selected PHY and <code>radr</code> is used to select the PHY. Nothing happens when <code>renb</code> is deasserted high. In byte-level transfer mode polling is not possible; packet availability is directly indicated by <code>drpa[x]</code> . <code>renb</code> must operate in conjunction with <code>rfclk</code> to access the FIFO buffers at a high enough rate to prevent FIFO buffer overflows. The system may deassert <code>renb</code> at anytime it is unable to accept another byte.
<code>radr</code> [4:0]	Link to PHY	Receive read address signals. The <code>radr</code> signal is used to select the FIFO buffer (and hence port) that is read from using the <code>renb</code> signal. For packet-level transfer, <code>radr</code> is also used to determine the FIFO buffers whose packet available signal is polled on the <code>prpa</code> output. Address 1Fh is the null-PHY address and must not be responded to by any PHY-layer device.

Table 3-12. POS-PHY Level 2 Receive Interface (Part 3 of 3)

Signal	Direction	Description
rval	PHY to link	Receive data valid signal. <code>rval</code> indicates the validity of the receive data signals. When <code>rval</code> is high, the receive signals (<code>rdat</code> , <code>rsop</code> , <code>reop</code> , <code>rmod</code> , <code>rxprty</code> and <code>rerr</code>) are valid. When <code>rval</code> is low, all receive signals are invalid and must be disregarded. <code>rval</code> transitions low on a FIFO buffer empty condition or on an end of packet. Data is not removed from the receive FIFO buffer while <code>rval</code> is deasserted. When deasserted, <code>rval</code> remains deasserted until current the PHY has been deselected. <code>rval</code> allows you to monitor the selected PHY during a data transfer, while monitoring or polling other PHYs is done using <code>prpa</code> or <code>drpa[x]</code> . The PHY-layer device tri-states <code>rval</code> when <code>renb</code> is deasserted. <code>rval</code> is also tri-stated when either the null-PHY address (<code>1Fh</code>), or an address not matching the PHY-layer device address, is presented on the <code>radr</code> signals when <code>renb</code> is sampled high (has been deasserted during the previous clock cycle).
prpa (3)	PHY to link	Receive polled multi-PHY packet available signal. <code>prpa</code> indicates when data is available in the polled receive FIFO buffer. When <code>prpa</code> is high, the receive FIFO buffer has at least one end of packet or a predefined number of bytes to be read (the number of bytes might be user programmable). <code>prpa</code> is low when the receive FIFO buffer fill level is below the assertion threshold and the FIFO buffer contains no end of packet. <code>prpa</code> allows to poll every PHY while transferring data from the selected PHY. <code>prpa</code> is driven by a PHY-layer device when its address is polled on <code>radr</code> . A PHY-layer device tri-states <code>prpa</code> when either the null-PHY address (<code>1Fh</code>), or an address not matching available PHY-layer devices, is provided on <code>radr</code> .
drpa[x] (4)	PHY to link	Receive packet available direct status indication signals. These signals provides direct status indication for the corresponding port (referred to by "x"). <code>drpa[x]</code> indicates when data is available in the receive FIFO buffer. When <code>drpa[x]</code> is high, the receive FIFO buffer has at least one end of packet or a predefined number of bytes to be read. The number of bytes is user programmable. <code>drpa[x]</code> is low when the receive FIFO buffer fill level is below the assertion threshold and the FIFO buffer contains no end of packet.
rflck	Link to PHY	Receive FIFO buffer write clock. <code>rflck</code> is used to synchronize data transfer transactions from the link-layer device to the PHY-layer device. <code>rflck</code> can cycle at a any rate from 25 MHz up to 50 MHz.

Notes to Table 3-12:

- (1) The 8-bit mode is an Altera extension to the POS-PHY Level 2 specification.
- (2) Not present in 8-bit mode.
- (3) Packet-level mode only.
- (4) Byte-level mode only.

Atlantic Interface

The Atlantic interface is a full-duplex synchronous point-to-point connection protocol. The POS-PHY Level 2 and 3 Compiler supports data widths of 8, 16, 32, and 64 bits on the Atlantic interface.



For further information on the Atlantic interface, refer to the *Atlantic Interface Functional Specification*.

Figure 3-17 shows the following two Atlantic interface control options (and all four interface types):

- Master source to slave sink

■ Master sink to slave source

The data flow on the Atlantic interface can be in either direction.

Figure 3-17. Atlantic Interface Control Options

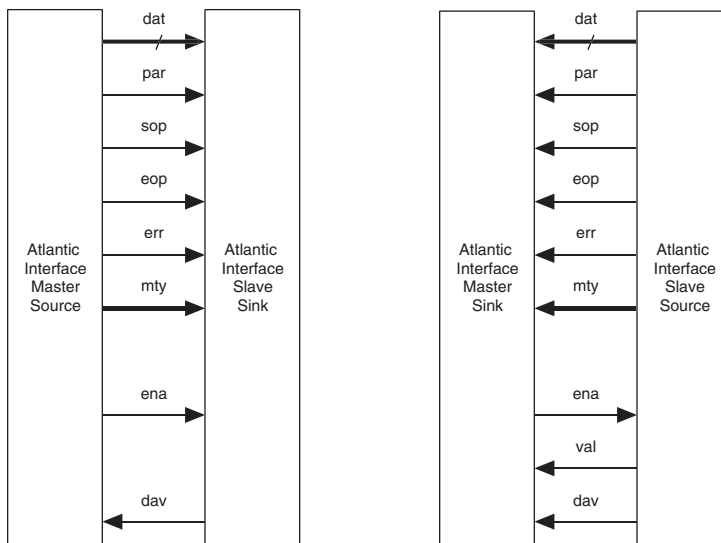

Note to Figure 3-17:

(1) Buses are unidirectional only.

A slave sink responds to write commands from the master source and behaves like a synchronous FIFO buffer.

A master sink generates read commands to a slave source, when it requires data, and behaves like a synchronous FIFO buffer controller.

Table 3-13 shows the Atlantic data interface signal definitions.

Table 3-13. Atlantic Interface Data Signals (Part 1 of 2)

Signal	Description
dat [63:0] dat [31:0] dat [15:0] dat [7:0]	Data bus. <code>dat</code> carries the packet octets that are transferred across the interface. Data is transmitted in big-endian order on <code>dat</code> , that is, most significant bit (MSB) first and all valid bits are contiguous with the MSB.
<code>par</code>	Parity signal (optional). <code>par</code> indicates the parity calculated over the <code>dat</code> bus. Odd and even parity are supported.
<code>sop</code>	Start of packet. <code>sop</code> delineates the packet boundaries on the <code>dat</code> bus. When <code>sop</code> is high, the start of the packet is present on the <code>dat</code> bus. <code>sop</code> is asserted on the first transfer of every packet.
<code>eop</code>	End of packet. <code>eop</code> delineates the packet boundaries on the <code>dat</code> bus. When <code>eop</code> is high, the end of the packet is present on the <code>dat</code> bus. <code>mty</code> indicates the number of invalid bytes the last word is composed of when <code>eop</code> is asserted. <code>eop</code> is asserted on the last transfer of every packet.

Table 3-13. Atlantic Interface Data Signals (Part 2 of 2)

Signal	Description
err	Error indicator. <code>err</code> indicates that the current packet is aborted and should be discarded. <code>err</code> may be asserted at any time during the current packet, but once asserted it can only be deasserted on the clock cycle after <code>eop</code> is asserted. The POS-PHY MegaCore function sees this signal as either <code>tterr</code> or <code>rerr</code> , depending on the data flow direction. Conditions that can cause <code>rerr</code> to be set can be, but are not limited to, FIFO buffer overflow, abort-sequence detection, missing SOP, missing EOP, and parity errors.
<code>mty[2:0]</code> <code>mty[1:0]</code> <code>mty[0:0]</code>	<p>Word empty bytes. <code>mty</code> indicates the number of invalid (empty) bytes of data in <code>dat</code>. The <code>mty</code> bus should always be all zero, except during the last transfer of a packet on <code>dat</code>. When <code>eop</code> is asserted, the number of invalid packet data bytes on <code>dat</code> is specified by <code>mty</code>. The definition of <code>mty</code> is compatible with the <code>mod</code> signal in the POS-PHY level 2 and 3 specifications.</p> <p><code>mty = '000'</code>, All <code>dat</code> bytes are valid <code>mty = '001'</code>, <code>dat [7:0]</code> are invalid <code>mty = '010'</code>, <code>dat [15:0]</code> are invalid <code>mty = '011'</code>, <code>dat [23:0]</code> are invalid <code>mty = '100'</code>, <code>dat [31:0]</code> are invalid <code>mty = '101'</code>, <code>dat [39:0]</code> are invalid <code>mty = '110'</code>, <code>dat [47:0]</code> are invalid <code>mty = '111'</code>, <code>dat [55:0]</code> are invalid</p> <p>An 8-bit <code>dat</code> bus requires no <code>mty</code> signal A 16-bit <code>dat</code> bus requires a <code>mty [0]</code> signal A 32-bit <code>dat</code> bus requires a <code>mty [1:0]</code> signal A 64-bit <code>dat</code> bus requires a <code>mty [2:0]</code> signal</p> <p><code>mty</code> can only be non-zero when <code>eop</code> is asserted.</p>

Table 3-14 shows the Atlantic control interface signal definitions.

Table 3-14. Atlantic Interface Control Signals

Signal	Description
ena	<p>Data transfer enable. <code>ena</code> is always driven by the master and controls the data flow across the interface.</p> <p>When the master is the source, <code>ena</code> behaves as a write enable from master to slave. The master asserts <code>ena</code> and <code>dat</code> simultaneously. When the slave observes <code>ena</code> asserted on the <code>clk</code> rising edge, it immediately captures the Atlantic data interface signals (see Figure 3-20).</p> <p>When the slave is the source, <code>ena</code> behaves as a read enable from master to slave. When the slave observes <code>ena</code> asserted on the <code>clk</code> rising edge it drives, on the next <code>clk</code> edge, the Atlantic data interface signals and asserts <code>val</code>. The master captures the data interface signals on the following <code>clk</code> rising edge. If the slave is unable to provide new data, it deasserts <code>val</code> for one or more clock cycles until it is prepared to drive valid data interface signals.</p> <p>For POS-PHY level 2 and 3 source variations that uses an Atlantic master sink interface on the B-side, the <code>bN_ena</code> output signals on the Atlantic master sink interfaces are not guaranteed to be zero during reset (<code>bN_reset_n</code> low). Instead, these signals reflect the value of the <code>bN_dav</code> input signals.</p> <p>The <code>bN_ena</code> signal may be asserted despite the assertion of the <code>bN_reset_n</code> signal. If your Atlantic source slave logic asserts the <code>bN_dav</code> while the POS-PHY Level 2 and 3 MegaCore function is in reset, the MegaCore function inadvertently begins to read data from the sink logic. The data read is not stored in the MegaCore function's buffers nor is it transmitted, which results in lost data.</p> <p>Ensure that the <code>bN_dav</code> input to the MegaCore function holds the desired value for <code>bN_ena</code> while the MegaCore function is in reset, which can be implemented in one of the following ways:</p> <ul style="list-style-type: none"> ■ Ensure that the Atlantic slave source logic is reset while the MegaCore function is in reset. ■ Drive the <code>bN_dav</code> input signal from a flip-flop reset by <code>bN_reset_n</code> and fed by your desired <code>dav</code> signal.
val	<p>Data valid. Present only on a slave source and master sink interface. When high, <code>val</code> indicates valid data signals. <code>val</code> is updated on every clock edge where <code>ena</code> is sampled asserted, and holds its current value along with the <code>dat</code> bus where <code>ena</code> is sampled deasserted. Invalid signals (<code>val</code> low) must be disregarded. To determine whether new data has been received, the master must qualify the <code>val</code> signal with the previous state of the <code>ena</code> signal.</p>
dav	<p>Data available. When the <code>dat</code> bus is in slave to master direction, if <code>dav</code> is high, the slave has at least <code>threshold</code> words available to be read, or the data can be read up to an end of packet without risk of underflow. When the <code>dat</code> bus is in master to slave direction, if <code>dav</code> is high, the slave has enough space for <code>threshold</code> words to be written. (1)</p>

Note to Table 3-13:

(1) `threshold` is implementation dependent and typically corresponds to FIFO buffer almost full/empty levels.

Timing

For a slave source to master sink there is a single-cycle delay after `ena` is asserted or deasserted and dataflow on `dat` (and associated data interface signals) starts or stops. However, the interface is pipelined, so the delay does not affect the net throughput of the interface.

[Figure 3-18 on page 3-30](#) shows the timing of the Atlantic interface with a master sink.

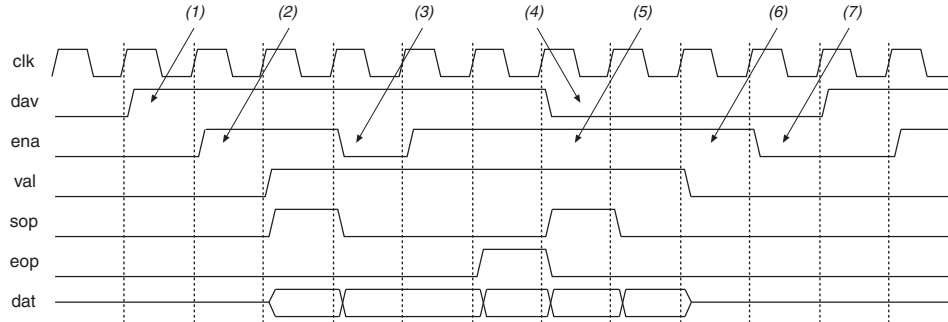
Figure 3-18. Atlantic Interface Timing—Slave Source to Master Sink**Notes to Figure 3-18:**

- (1) Slave source indicates that data is available (either `threshold` words available, or EOP).
- (2) Master sink begins reading data.
- (3) Master sink decides to stop reading the data for one clock cycle. `val` remains asserted and `data`, `sop`, and `eop` hold their current values.
- (4) Slave source indicates that it has less than `threshold` words available. The master sink can continue to read data until it detects `val` deasserted.
- (5) Master sink continues to read data, validates data with `val`.
- (6) Slave source cannot supply any more data, so deasserts `val`.
- (7) Master sink goes idle until `dav` is re-asserted.

Figure 3-19 shows the timing of the Atlantic interface with a master source.

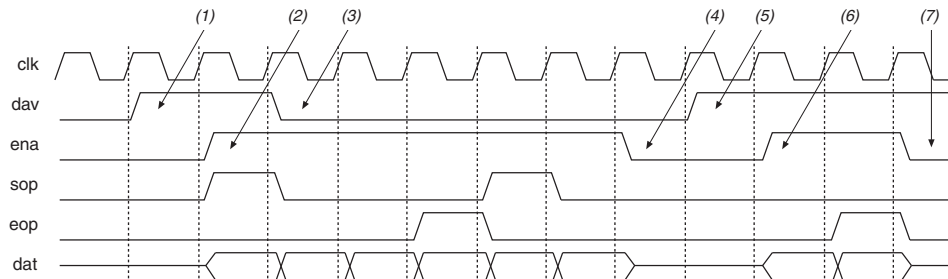
Figure 3-19. Atlantic Interface Timing—Master Source to Slave Sink**Notes to Figure 3-19:**

- (1) Slave sink indicates it has space for at least `threshold` words.
- (2) The master source begins writing data to the slave sink.
- (3) Slave sink indicates it has space for `threshold` words. Master source can continue to send data, but must ensure that the slave sink does not overflow.
- (4) Master source stops sending data
- (5) Slave sink indicates it has space for at least `threshold` words.
- (6) Master source begins writing data to the slave sink.
- (7) Slave sink indicates it still has space, but the master source has run out of data.

Signal Naming Convention

When you include an Atlantic interface in a design, the IP Toolbench generates the signal names, which are prefixed by `<port name>_`, such as, `b1_ena`, `b1_val`, `b2_ena`, `b2_val`.

Compatibility

To ensure that individual implementations of an Atlantic interface are compatible they must have the following:

- The same data bus width
- Compatible data directions (data source connecting to data sink)
- Compatible control interfaces (master interface connecting to slave interface)
- Compatible FIFO buffer threshold levels (slave sink can overflow, and slave source can operate inefficiently if thresholds are incorrectly set)

Example Packet Types

Figure 3–20 shows an example data packet. The assumption is that `ena` and `val` are continuously asserted.

Figure 3–20. Example Data Packet

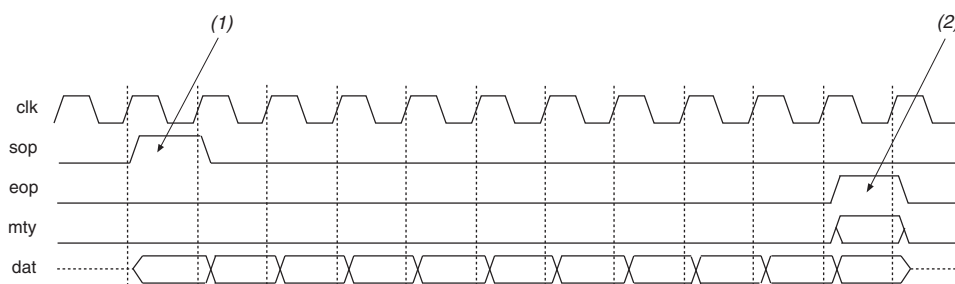

Notes to Figure 3–20:

- (1) `sop` marks the start of the data packet.
- (2) `eop` marks the end of the data packet, and `mty` indicates the number of invalid bytes.

MegaCore Verification

Before releasing a version of the POS-PHY Level 2 and 3 Compiler, Altera runs a comprehensive regression test, which executes the wizard to create the instance files. Next, VHDL testbenches are run in the ModelSim simulator, to exercise the VHDL models. The regression suite covers various parameters such as input and output interface types and bus widths, varying FIFO buffer parameters, and relevant architecture options.

Several computers automatically run these simulations for many days, to ensure that the MegaCore function is robust. In addition to automated computerized regression testing, human testers use IP Toolbench and test many combinations of options and buttons.

The POS-PHY Level 2 and 3 Compiler has also been verified for interworking with simulation models for two PMC-Sierra chips. The PM5351 uses a POS-PHY level 2, 4-channel, PHY interface and was tested by connecting a POS-PHY level 2 link interface (configured by the POS-PHY Level 2 and 3 Compiler). The PM7325 uses a POS-PHY level 3 PHY-layer or link-layer interface, and was tested by connecting a POS-PHY level 3 link-layer or PHY-layer interface (configured by the POS-PHY Level 2 and 3 Compiler). In all cases packets of random length were successfully passed through the system, and verified at the other end.

Revision History

The following table shows the revision history for this user guide.

Date	Version	Changes Made
November 2009	9.1	Added obsolescence notification
March 2009	9.0	Added Arria® II GX device support
November 2008	8.1	No changes.
May 2008	8.0	<ul style="list-style-type: none"> ■ Added support for Stratix® IV devices ■ Updated <code>ena</code> signal description ■ Corrected <code>rfclk</code> rate
October 2007	7.2	Improved description of <code>rerr</code> signal.
May 2007	7.1	<ul style="list-style-type: none"> ■ Updated the device support ■ Improved <code>rsx</code> signal description
December 2006	7.0	Updated the device support.
December 2006	6.1	<ul style="list-style-type: none"> ■ Updated the release information ■ Updated the directory structure ■ Added the fixed burst length information to the FIFO buffer settings procedure ■ Added a procedure for running a testbench simulation with NativeLink

How to Contact Altera

For the most up-to-date information about Altera® products, see the following table.







Contact <i>(Note 1)</i>	Contact Method	Address
Technical support	Website	www.altera.com/support
Technical training	Website	www.altera.com/training
	Email	custrain@altera.com
Altera literature services	Email	literature@altera.com
Non-technical support (General) (Software Licensing)	Email	nacomp@altera.com
	Email	authorization@altera.com

Note:

(1) You can also contact your local Altera sales office or sales representative.

Typographic Conventions

The following table shows the typographic conventions that this document uses.

Visual Cue	Meaning
Bold Type with Initial Capital Letters	Indicates command names, dialog box titles, dialog box options, and other GUI labels. For example, Save As dialog box.
bold type	Indicates directory names, project names, disk drive names, file names, file name extensions, and software utility names. For example, \qdesigns directory, d: drive, and chiptrip.gdf file.
<i>Italic Type with Initial Capital Letters</i>	Indicates document titles. For example: <i>AN 519: Stratix IV Design Guidelines.</i>
<i>Italic type</i>	Indicates variables. For example, $n + 1$. Variable names are enclosed in angle brackets (<>). For example, <file name> and <project name>.pof file.
Initial Capital Letters	Indicates keyboard keys and menu names. For example, Delete key and the Options menu.
"Subheading Title"	Quotation marks indicate references to sections within a document and titles of Quartus II Help topics. For example, "Typographic Conventions."
Courier type	Indicates signal, port, register, bit, block, and primitive names. For example, data1, tdi, and input. Active-low signals are denoted by suffix n. Example: resetn. Indicates command line commands and anything that must be typed exactly as it appears. For example, c:\qdesigns\tutorial\chiptrip.gdf. Also indicates sections of an actual file, such as a Report File, references to parts of files (for example, the AHDL keyword SUBDESIGN), and logic function names (for example, TRI).
1., 2., 3., and a., b., c., and so on.	Numbered steps indicate a list of items when the sequence of the items is important, such as the steps listed in a procedure.
	Bullets indicate a list of items when the sequence of the items is not important.
	The hand points to information that requires special attention.
 CAUTION	A caution calls attention to a condition or possible situation that can damage or destroy the product or your work.
 WARNING	A warning calls attention to a condition or possible situation that can cause you injury.
	The angled arrow instructs you to press the enter key.
	The feet direct you to more information about a particular topic.