

Using LEDs as Light-Level Sensors and Emitters

Modulating LED power based on ambient light level increases battery life, a particularly helpful feature in a device where battery life is measured in days. Using a very simple circuit, Altera’s MAX II and MAX IIZ CPLDs can measure the analog light level of their environments and then drive an LED at a proportional analog intensity level. Controlling the LED intensity based on ambient light as demonstrated reduces LED energy usage by more than 47 percent without affecting appearance.

Introduction

In portable electronic products, a common use for LEDs is a “heartbeat” indicator that shows power status, battery condition, or Bluetooth connection activity. The LED can be a major factor in determining battery life, as its intensity is directly proportional to power drain. LEDs are designed to be easily seen in bright ambient light, yet it can be assumed that much of the time a portable device is in a dark purse or pocket. A low-intensity LED indicator extends battery life but is useless in a bright environment. Modulating LED power based on ambient light level would increase battery life, a particularly helpful feature in a device where battery life is measured in days.

Regulating the LED’s Intensity

A pulse-width modulator (PWM) is very effective at regulating the LED’s intensity with very little wasted energy. The only feature necessary to complete a light-sensitive flash intensity system is an ambient light-level sensor, which can be added to a CPLD or FPGA circuit with no additional components. The light sensor uses the same blinking LED to measure ambient light level. The LED is forward biased to emit light and reverse biased to act as a light detector. **Figure 1** shows how the LED is biased for emitting light and for sensing light with a relaxation oscillator. The frequency of oscillation is proportional to light intensity, allowing the use of a PWM to regulate LED light intensity output.

Figure 1. Bias Schematics for Using LED as Sensor and Emitter

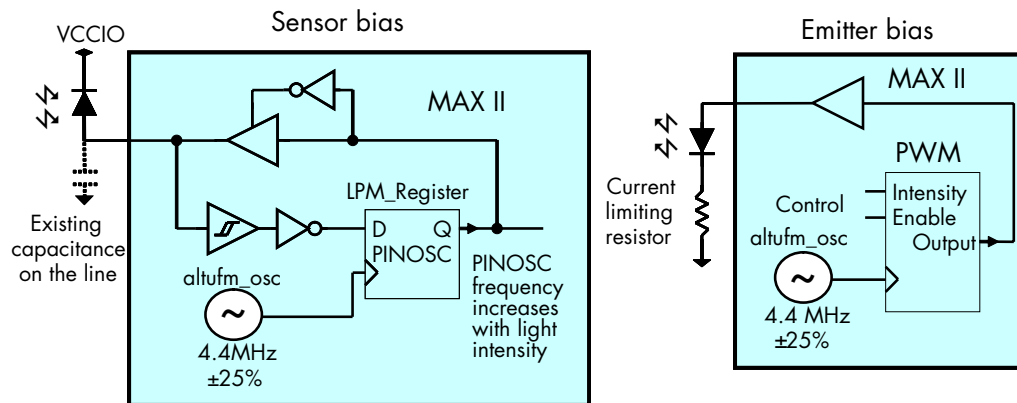

A very simple feedback system can be created for a flashing light. The LED flash intensity is determined by a value presented to the PWM, which is calculated when the LED is off. It is biased as a sensor connected to a relaxation oscillator. The oscillator output feeds into a frequency counter, where the frequency is proportional to the ambient light level. The frequency counter output is the value that controls the intensity of the LED PWM. It is possible to have only one sensor controlling the intensity of multiple LEDs.

Figure 2 shows the block diagram for a flashing LED with a feedback loop that controls the intensity based on the ambient light level. It would be very easy to add an additional control to enable or disable the flash function or the flash rate (not shown).

Figure 2. Simplified Block Diagram of LED Flasher with Intensity Control

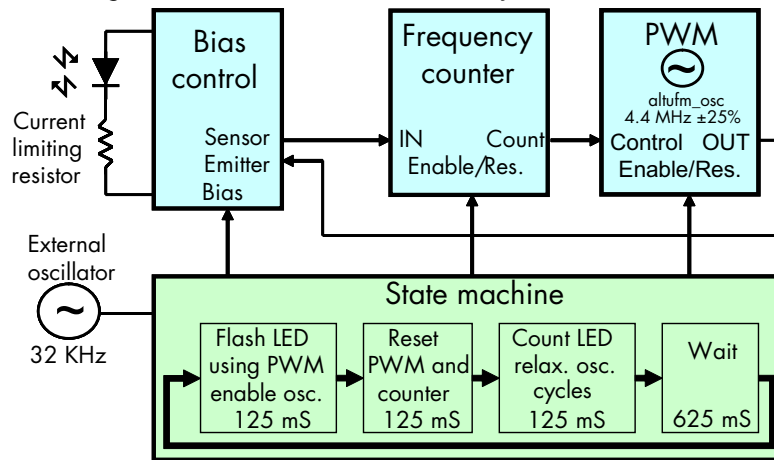
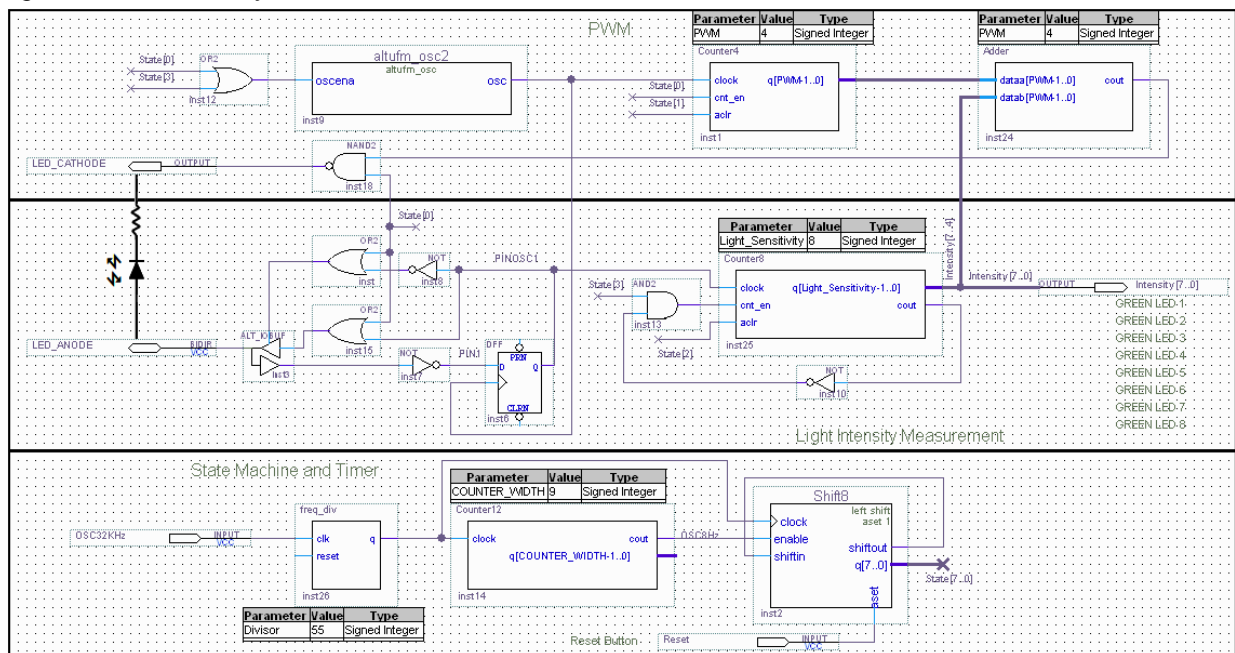

Figure 3 shows an Altera® MAX® II CPLD design implemented on a MAX II Starter Kit that generates a 1-Hz flash rate with 125 ms on period LED flash with a PWM duty cycle from 6.25 percent to 100 percent (15 levels). Various tests with discrete LEDs plugged into the #4 and #8 terminals of the right-side 2x5 header have determined that the four MSBs of an 8-bit counter that samples the LED sensor PINOSC frequency for 125 ms are the optimum values to control LED intensity.

Figure 3. LED Intensity Control Demonstration Circuit



The circuit is divided into three sections. The state machine at the bottom controls circuit operation with eight states, each of which are active for 125 ms as determined by the Counter12 timer, which is clocked by the MAX IIZ Demo Board's 32-kHz oscillator input. In the case of MAX II Starter Kit, the Counter12 is clocked by the 3.3-MHz internal oscillator. An additional block, freq_div is added to allow user to control the input frequency. The reset switch puts the state machine into the LED PWM-controlled flash state, State0, which can be used to stop the sampling and sustain the PWM value reached when reset was pushed. This function allows the LED intensity to be observed after it is removed from a light source.

State Machine States

The state machine states include:

- State0 – the LED PWM-controlled flash state (reset state)
- State1 – the PWM-counter reset state
- State2 – the intensity-counter reset state
- State3 – the light intensity measurement state
- State4, State5, State6, and State7 – unused states

As shown in [Figure 4](#), an LED is connected to pins LED_CATHODE and LED_ANODE on the MAX IIZ Demo Board, which in turn are connected to terminals #4 and #8 of the right-side 2x5 header. For the MAX II device on the MAX II Starter Kit, shown in [Figure 5](#), pins LED_CATHODE and LED_ANODE are connected to terminal #3 and terminal #4 of the 2x17 header. The bias of the LED_CATHODE and LED_ANODE terminals are determined by the state of the state machine: in State3 they are biased as a sensor, in all other states they are biased as an emitter. State0 is the only state in which LED_CATHODE can be a “0” to light the LED.

Figure 4. Testing LEDs with the MAX IIZ Demo Board

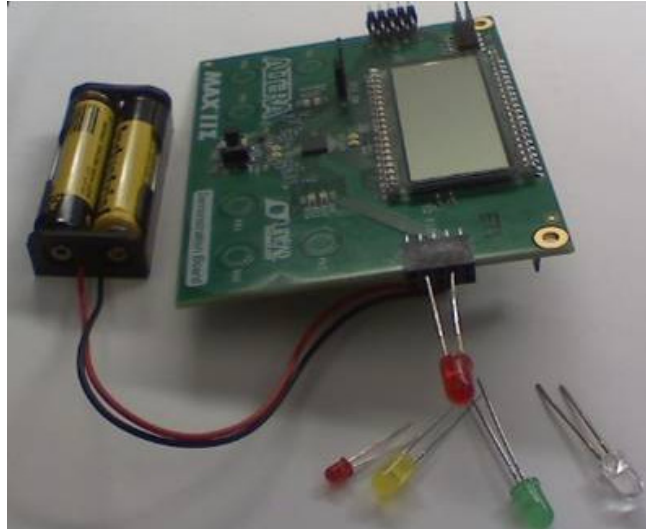
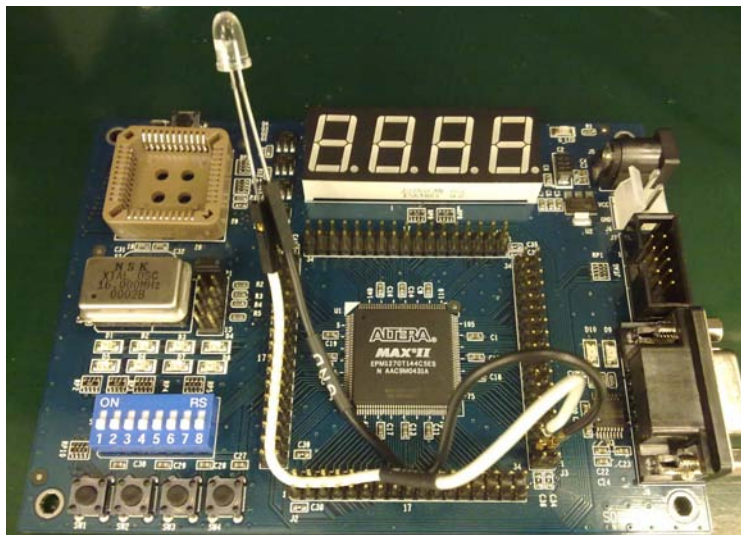

Figure 5. Testing LEDs with the MAX II Starter Kit



The middle light intensity measurement block is simply an LED biased as a detector, then connected to a relaxation oscillator connected to an 8-bit counter. The counter measures the number of LED oscillations in 125 ms, the duration of State3 that enables the Counter8 counter. The Counter8 block’s carry-out signal, COUT, is used to saturate the count to FF and prevent it from wrapping around to 00, while the four MSBs of the counter control the PWM intensity.

The top block is a simple PWM circuit that uses the internal 4.4-MHz oscillator as the modulation carrier frequency. The Counter4 block drives a simple 4-bit adder with the carry-in signal tied to the VCC. The other adder input is connected to the light intensity value (the four MSBs of Counter8). Counter4 cycles from 0 to 15 and then repeats. When the sum of Counter4 plus the intensity value plus one is greater than 15, then the COUT of the adder is “1.” Thus, the carry-out signal of the 4-bit adder is the PWM output, which drives the LED. For example:

- A “0” from the intensity measurement results in a “0” at carry out when Counter4 is 0–14 and a “1” when Counter4 is 15. This is a 6.25 percent duty cycle or a very low intensity level.
- A “7” from the intensity measurement results in a “0” at carry out when Counter4 is 0–7 and a “1” when Counter4 is 8–15. This is a 50 percent duty cycle or medium intensity level.
- A “15” from the intensity measurement results in no “0” at carry for any Counter4 value and a “1” when Counter4 is 0–15. This is a 100 percent duty cycle or full intensity level.

Figure 6 shows a similar design with additional features to aid in the development of a design using a specific LED or environment. The first feature added is an 8-bit PWM, which can be easily increased in resolution if necessary.

Figure 6. LED Sensor and PWM Development Platform

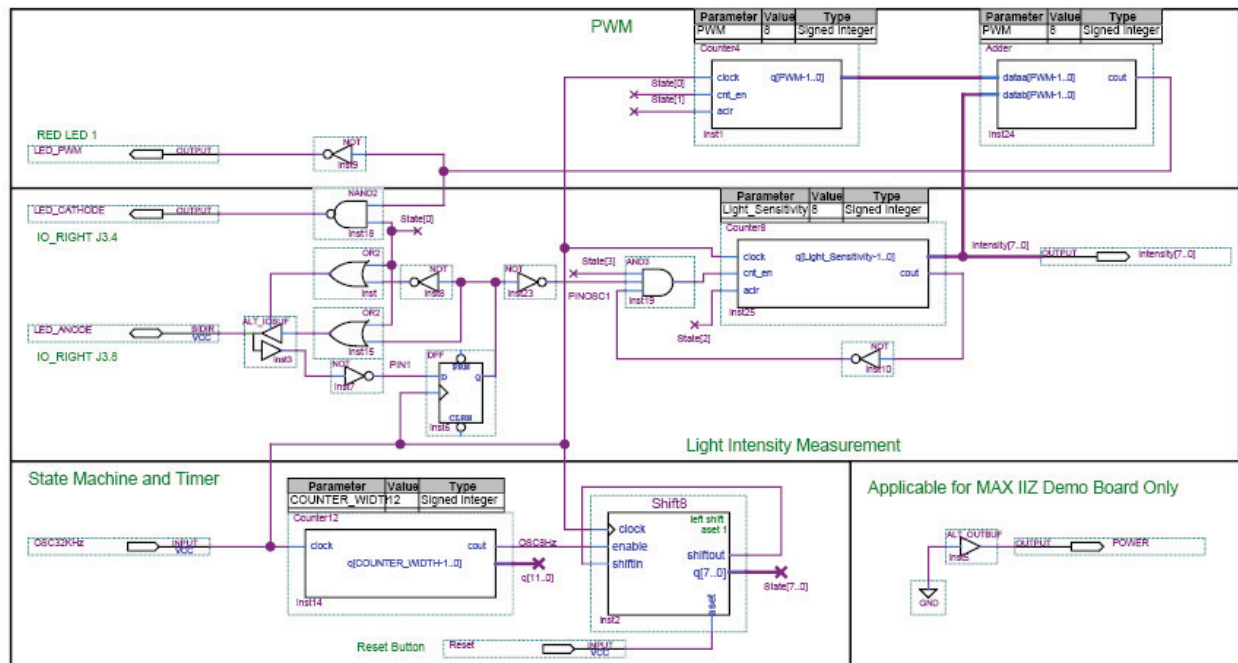

The next addition is connection of the outputs of the intensity counter Intensity [7 . . 0] to the eight green LEDs on the MAX IIZ Demo Board. This makes it easy to monitor the light intensity measurement. When the push button is held, the sampling stops, the unit displays the last reading, and the LED stops flashing and stays lit at that intensity until the button is released. For the MAX II Starter Kit, the push button, SW2, performs the same function. The red LED D1 on the demo board is connected to LED_PWM and is a second output of the PWM value. This makes pointing the sensor LED at a light and seeing the resulting change in flash brightness easier to observe. In addition to this feature, the design is modified to contain only one clock source.

Setting the I²C Interface

The LED sensor and emitter reference design support an I²C interface on both the MAX IIZ Demo Board and the MAX II Starter Kit. For the I²C interface (Figure 7) in this design, the CPLD has a built-in 7-bit address that can be easily modified. The general-purpose I/O ports in this design, GPIO_input [7..0] and GPIO_output [0], are connected to the Intensity_reg8 and one LED respectively, as in the I²C design example.

Figure 7. I²C Interface in LED Sensors and Emitter Design

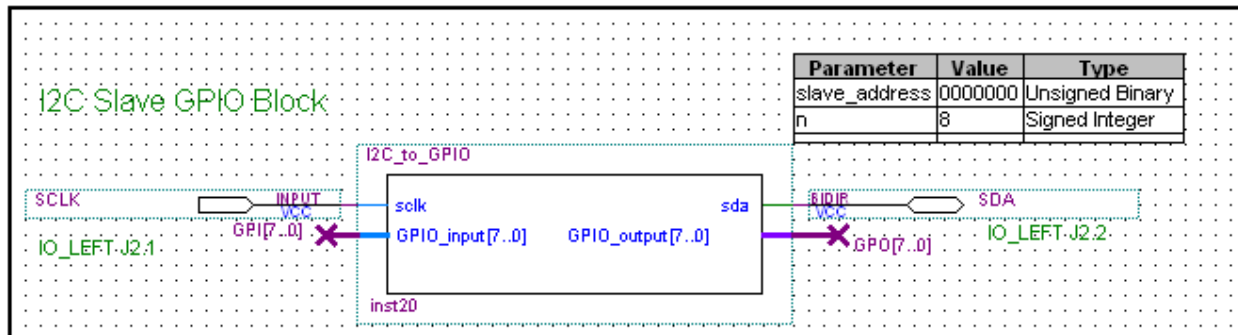

- Refer to the [LED sensor and emitter reference design](#) with an I²C interface using the MAX IIZ Demo Board for detailed information on the connection for I²C interface.
- For more information for the GPIO pin expansion using I²C Bus interface, refer to [AN 494: GPIO Pin Expansion Using I²C Bus Interface in MAX II CPLDs](#).

Conclusion

Using a very simple circuit, the MAX II CPLD can measure the analog light level of its environment and then drive an LED at a proportional analog intensity level. The sensing and emitting is performed with the same LED and an optional bias resistor. The programmability of the CPLD makes adjusting the parameters of the circuit to the characteristics of any LED fast and easy. The power consumption of a flashing LED can be reduced by increasing the flash period, decreasing the flash pulse width, or decreasing intensity, but it is assumed that designers have already adjusted these values to optimum levels. Controlling the LED intensity based on ambient light as demonstrated reduces LED energy usage by more than 47 percent without affecting appearance.

Further Information

The following reference designs must be opened with Quartus® II design software:

- “Light-Sensing LED and PWM Flashing LED Development Platform” reference design (Figure 6):
 - For the MAX IIZ Demo Board: www.altera.com/literature/wp/MAXIIZ_LED_Sensor_Display.qar
 - For the MAX II Starter Kit: www.altera.com/literature/wp/MaxIIStarterKit_led.qar
 - “LED Sensor and Emitter” reference design (Figure 7):
www.altera.com/literature/wp/LED_Sensor_PWM_I2C.qar
-
- *Implementing a Flexible CPLD-Only Digital Dashboard for Automobiles:*
www.altera.com/literature/wp/wp-01072-implementing-flexible-cpld-only-digital-dashboard-automobiles.pdf
 - *A Flexible Architecture for Fisheye Correction in Automotive Rear-View Cameras:*
www.altera.com/literature/wp/wp-01073-flexible-architecture-fisheye-correction-automotive-rear-view-cameras.pdf
 - *Creating Low-Cost Intelligent Display Modules With an FPGA and Embedded Processor:*
www.altera.com/literature/wp/wp-01074-creating-low-cost-intelligent-display-modules-with-fpga.pdf
 - *Applying Graphics to FPGA-Based Solutions:*
www.altera.com/literature/wp/wp-01075-applying-graphics-to-fpga-based-solutions.pdf
 - *AN 494: GPIO Pin Expansion Using I²C Bus Interface in MAX II CPLDs:*
www.altera.com/literature/an/an494.pdf
 - Rafael Camarota “Use an LED to sense and emit light,” *EDN*, May 14, 2009:
www.edn.com/article/CA6656305.html
 - Geoff Nicholls, “Red LEDs function as light sensors,” *EDN*, March 20, 2008:
www.edn.com/article/CA6541376
 - Howard Myers, “Stealth-mode LED controls itself,” *EDN*, May 25, 2006:
www.edn.com/article/CA6335303
 - Dhananjay V Gadre and Sheetal Vashist, “LED senses and displays ambient-light intensity,” *EDN*, Nov. 9, 2006:
www.edn.com/article/CA6387024
 - Paul Dietz, William Yerazunis, and Darren Leigh, “Very Low-Cost Sensing and Communication Using Bidirectional LEDs,” Mitsubishi Research Laboratories, July 2003:
www.merl.com/reports/docs/TR2003-35.pdf

Acknowledgements

- Rafael Camarota, Non-Volatile Product Line Manager, Low-Cost Products Group, Altera Corporation



101 Innovation Drive
San Jose, CA 95134
www.altera.com

Copyright © 2009 Altera Corporation. All rights reserved. Altera, The Programmable Solutions Company, the stylized Altera logo, specific device designations, and all other words and logos that are identified as trademarks and/or service marks are, unless noted otherwise, the trademarks and service marks of Altera Corporation in the U.S. and other countries. All other product or service names are the property of their respective holders. Altera products are protected under numerous U.S. and foreign patents and pending applications, maskwork rights, and copyrights. Altera warrants performance of its semiconductor products to current specifications in accordance with Altera's standard warranty, but reserves the right to make changes to any products and services at any time without notice. Altera assumes no responsibility or liability arising out of the application or use of any information, product, or service described herein except as expressly agreed to in writing by Altera Corporation. Altera customers are advised to obtain the latest version of device specifications before relying on any published information and before placing orders for products or services.