

Integrating PLC Systems on a Single FPGA or SoC

Programmable Logic Controllers with Human-Machine Interfaces

Programmable logic controller (PLC) systems are getting smaller, powerful, and more integrated with advanced functionality such as built-in human-machine interfaces (HMI). With sizes ranging from small compact PLCs to high-end PLCs that can control thousands of nodes, PLC system architecture must be scalable to support size and performance requirements. To build scalable hardware PLC platforms, you need to combine a high-performance applications processor with a programmable logic fabric for customization.

Altera® Cyclone V SoCs integrate a hard processor system (HPS) consisting of a dual-core ARM® processor, peripherals, and memory controllers with the FPGA fabric using a high-bandwidth interconnect backbone. You get the performance and ecosystem of an applications-class ARM processor with the flexibility, low cost, reduced board space, and low power consumption of our 28 nm Cyclone V FPGAs.

To help you more quickly develop a complete PLC with integrated HMI design on a single chip, we teamed with 3S-Smart Software Solutions GmbH, a leading PLC software developer, and EXOR International, a leader in HMI development, to create a single chip implementation of a powerful PLC with integrated 2.5D graphics-capable HMI.

Partitioning Single PLC Design on a Cyclone V SoC

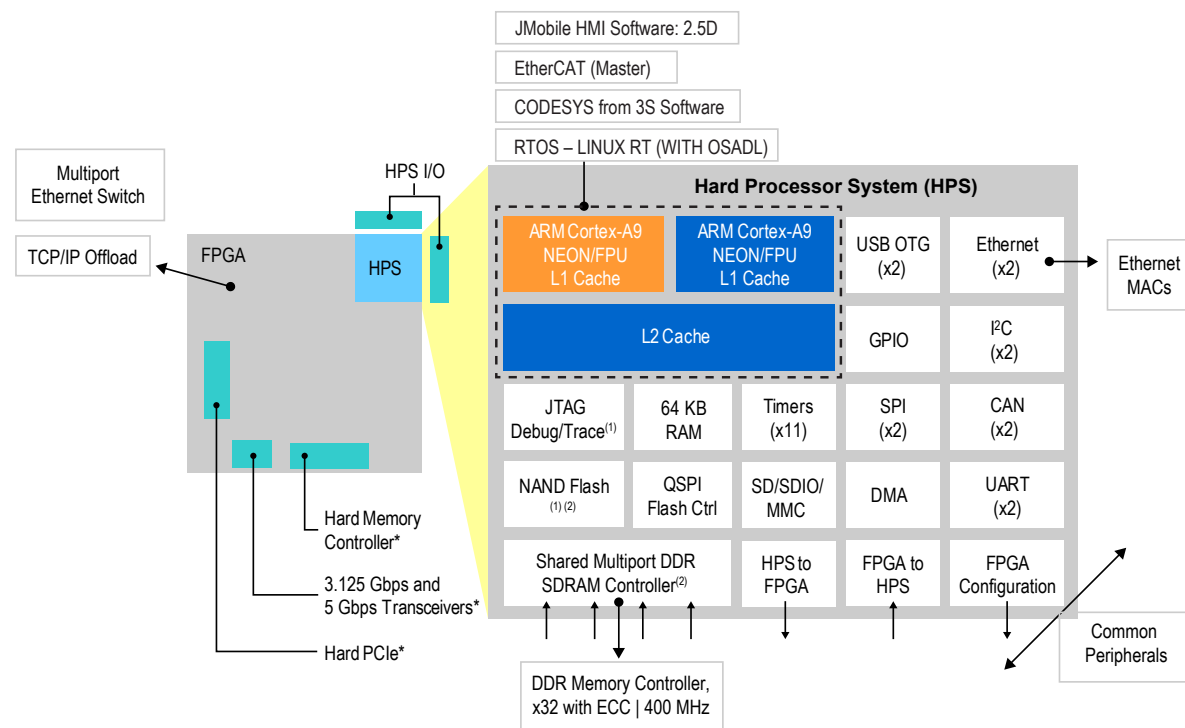

Reference Design Components

- Exor JMSoC Linux Run-time (License required)
- ARM Development Studio™ (DS-5™) Toolkit Altera® Edition, Cyclone V SoC Linux RTOS Board Support Package (OSADL)
- EXor JMobile Studio (Altera edition)
- EXor UltiEVC embedded video controller intellectual property (IP) core including Linux frame buffer video driver
- 3S-Smart Software Solutions CODESYS IEC 61131-3 development system (IDE) and SoftMotion/CNC extension including CODESYS EtherCAT Master Stack (evaluation version)
- User manual and application notes for Altera Cyclone V SoC Development Kit
- HMI
 - Rugged industrial 15", 1500 candela per square meter (cd/m2) display with multi-touch capacitive glass
 - UltiEVC video controller instructions per clock (IPC) core integrated in FPGA
 - 1024x768 graphics resolution, 16 bpp
 - Frame buffer driver, 16 bpp, one layer, unified memory architecture

Optimized Software Architecture

Altera and our partners also packaged all the software you will need to build your PLC. This includes the operating system (OS), middleware, communication protocol stacks, graphics, and PLC run-time software.

All Available Software Packages Required For an Integrated PLC/HMI System

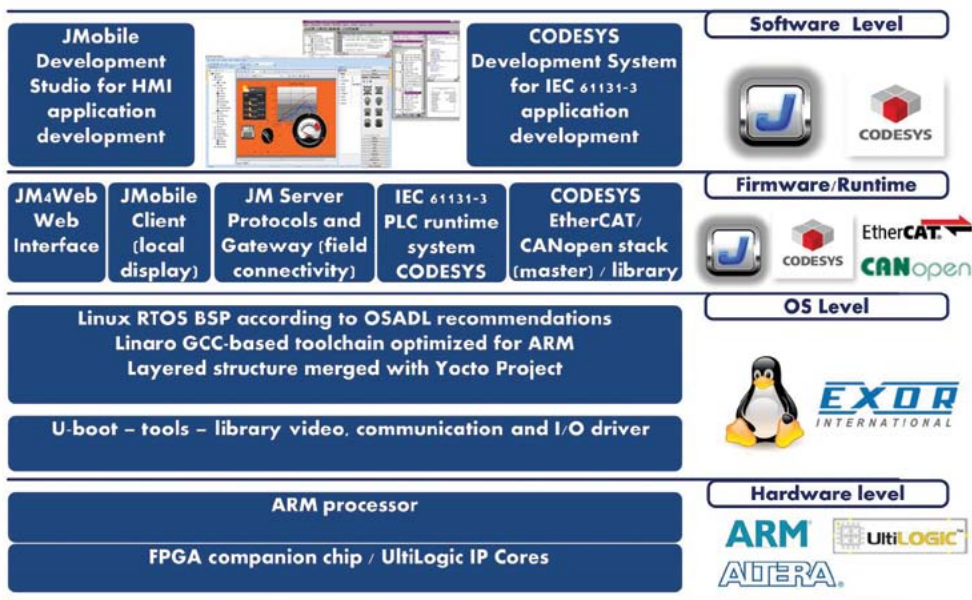

Reference Design

A reference design is available to develop your PLC/HMI design. This PLC/HMI system can be managed with a touchscreen display that manipulates EtherCAT slaves such as multiaxis drives and I/O modules. The design includes the EtherCAT communication protocol and the industry-standard CODESYS PLC run-time software.

Qualified customers may request the reference design as well as a loaner hardware platform for internal evaluations at <http://www.exorint.net/>

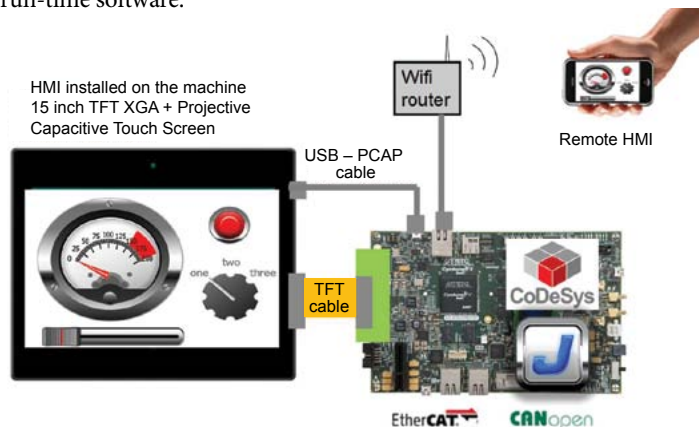

Want to dig deeper?

For more information about Altera's FPGAs and SoCs for PLCs, contact your local Altera sales representative, or visit www.altera.com/industrial.

Altera Corporation
101 Innovation Drive
San Jose, CA 95134
USA
www.altera.com

Altera European Headquarters
Holmers Farm Way
High Wycombe
Buckinghamshire
HP12 4XF
United Kingdom
Telephone: (44) 1494 602000

Altera Japan Ltd.
Shinjuku i-Land Tower 32F
6-5-1, Nishi-Shinjuku
Shinjuku-ku, Tokyo 163-1332
Japan
Telephone: (81) 3 3340 9480
www.altera.co.jp

Altera International Ltd.
Unit 11- 18, 9/F
Millennium City 1, Tower 1
388 Kwun Tong Road
Kwun Tong
Kowloon, Hong Kong
Telephone: (852) 2 945 7000
www.altera.com.cn

