

Title		<Title>
Size	Document Number	Rev
B	80-pin Edge Connector, uSD Card, 20x2 pin header	<RevCode>
Date:	Monday, May 06, 2013	Sheet 2 of 7

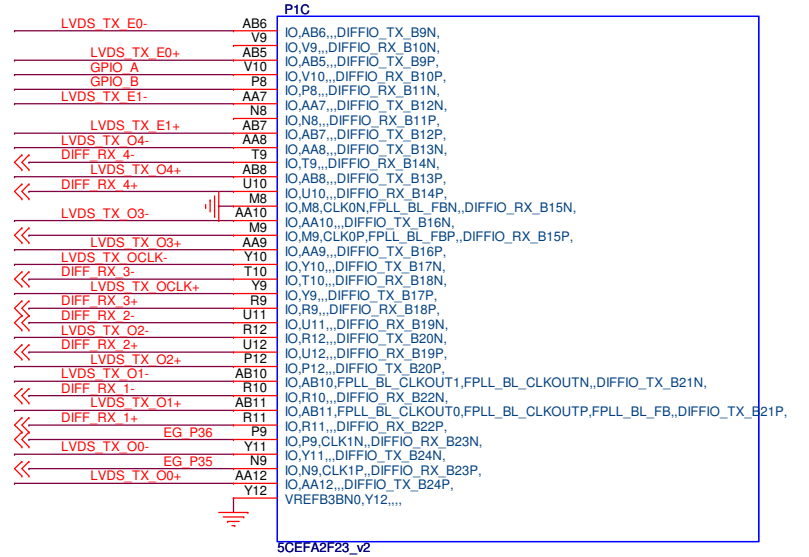

AS mode  
MSEL 4 3 2 1 0  
Fast 1 0 0 1 0  
Standard 1 0 0 1 1

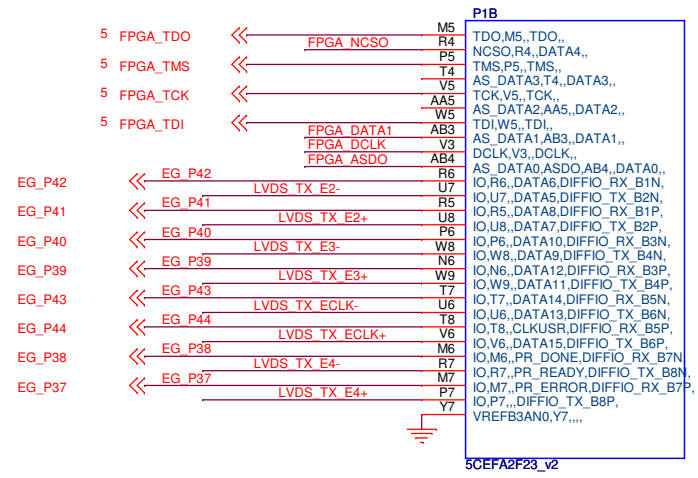
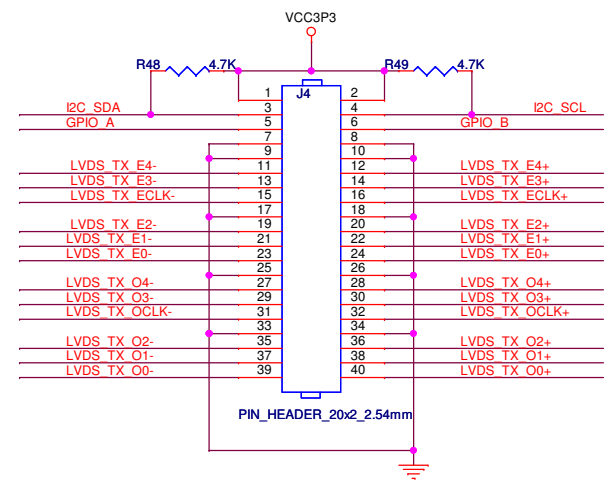
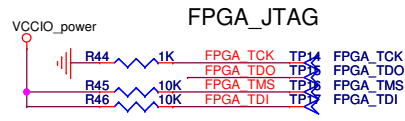
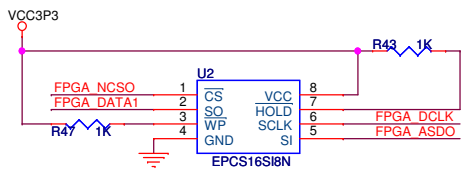
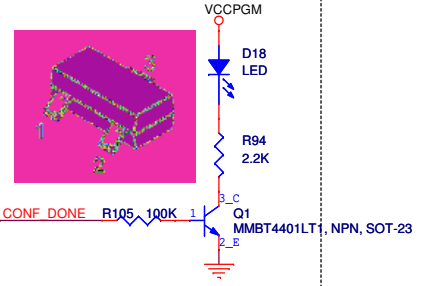
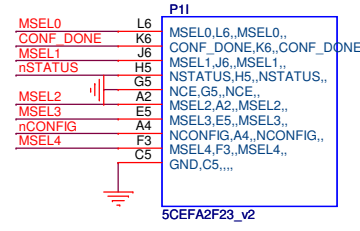
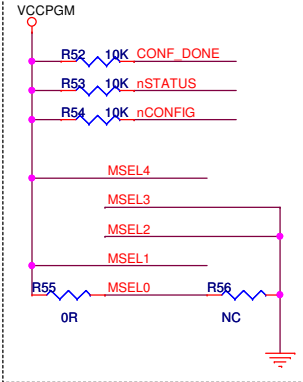

Title		<Title>
Size	Document Number	Rev
B	LVDS	<RevCode>
Date:	Monday, May 06, 2013	Sheet 3 of 7

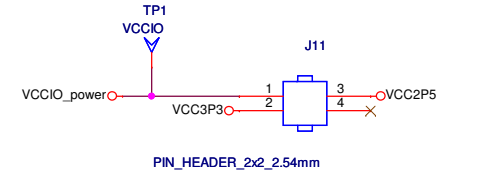
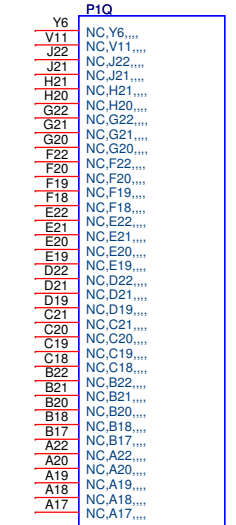
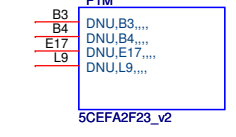
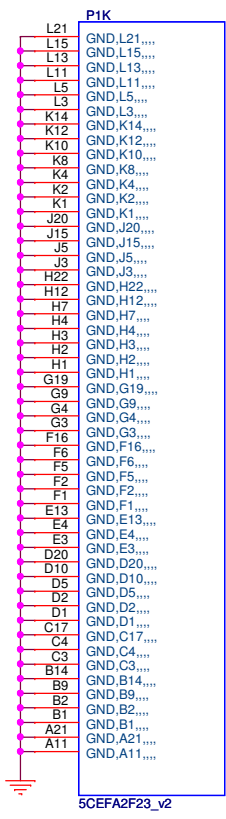
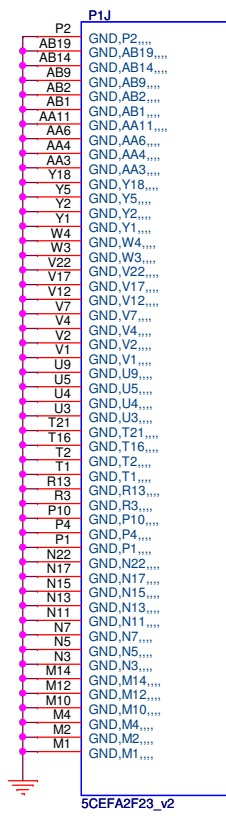
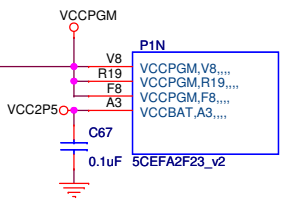
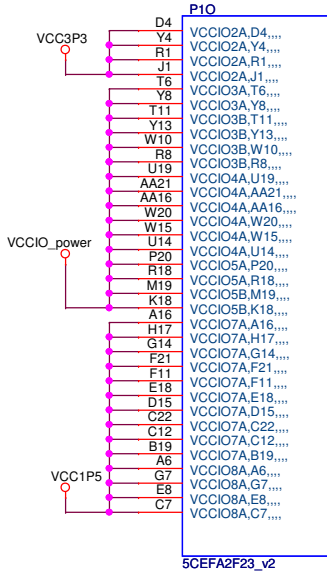
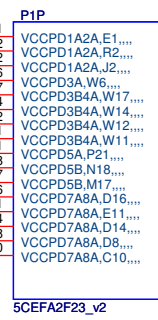
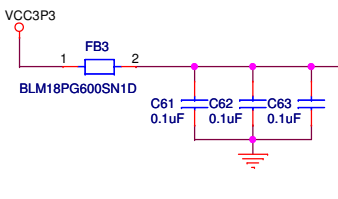
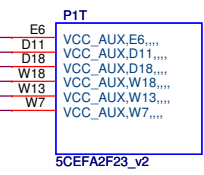
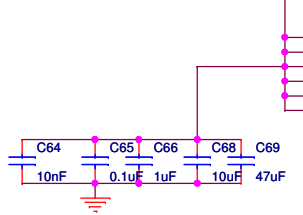
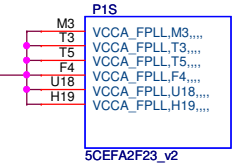
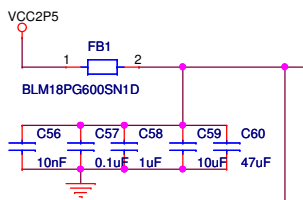
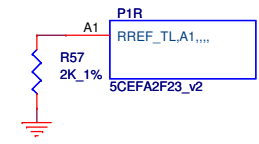
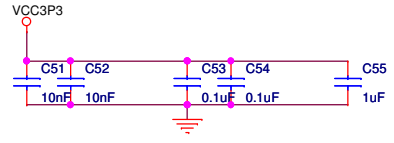
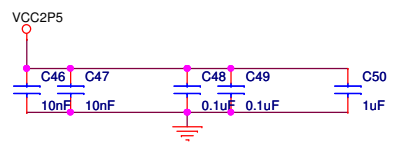
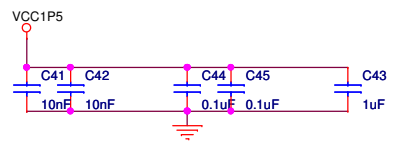
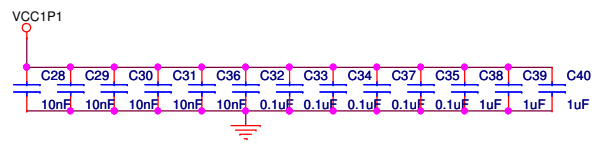
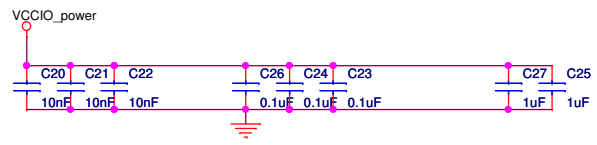
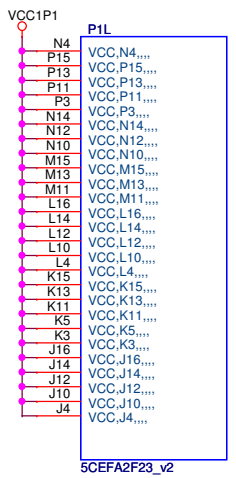

Title	<Title>	
Size	Document Number	Rev
B	FPGA Power	<RevCode>
Date:	Thursday, April 25, 2013	Sheet 4 of 7

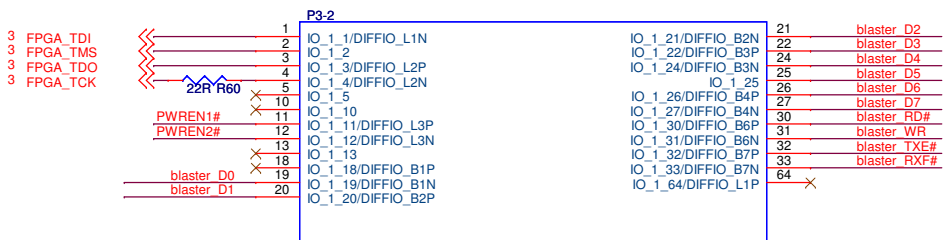

**MAX V 5M80ZE64**  
 VERSION : 1.0  
 PAGE : 2 of 5  
 DATE : FEB\_10 2011

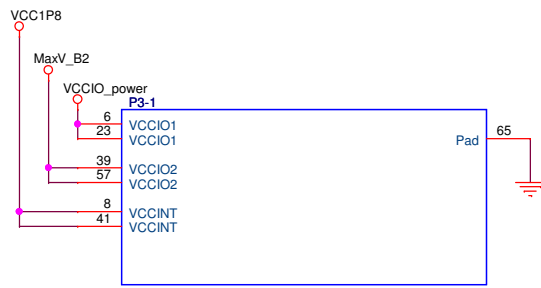

**MAX V 5M80ZE64**  
 VERSION : 1.0  
 PAGE : 1 of 5  
 DATE : FEB\_10 2011

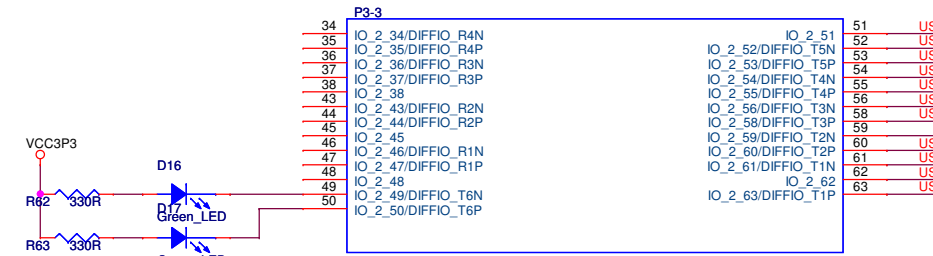
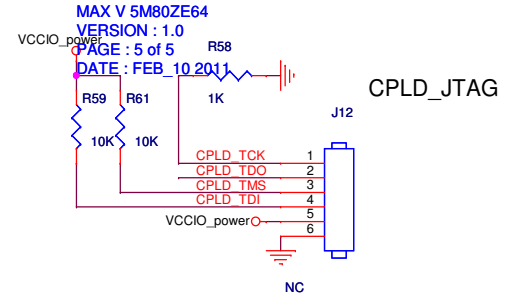
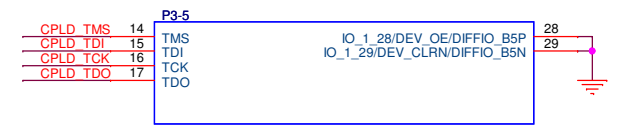

**MAX V 5M80ZE64**  
 VERSION : 1.0  
 PAGE : 3 of 5  
 DATE : FEB\_10 2011

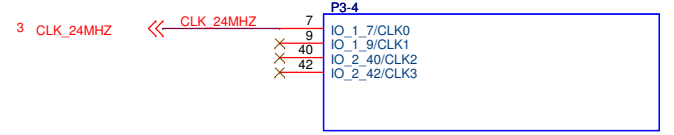
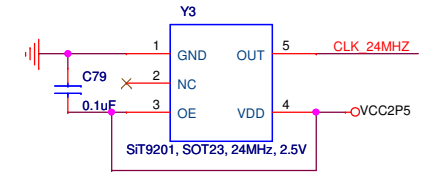
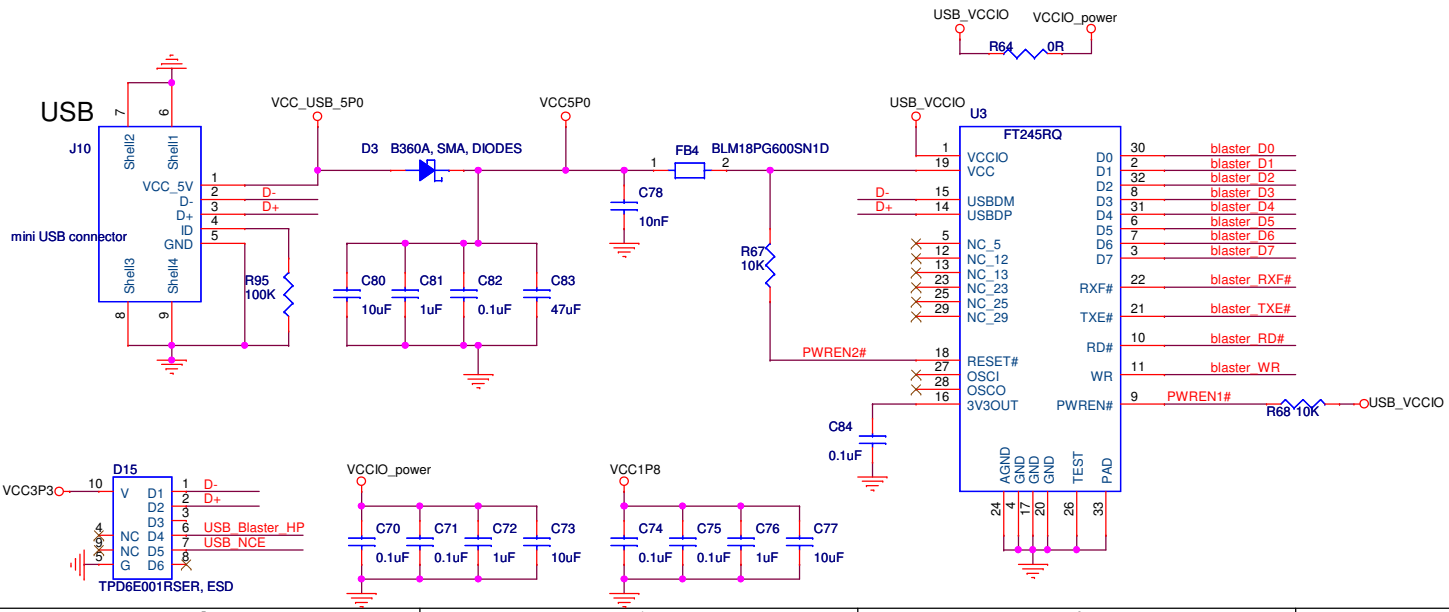
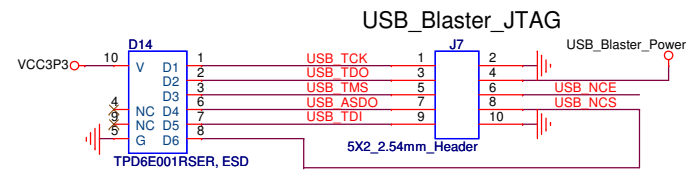
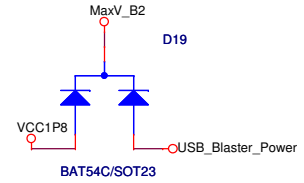

**MAX V 5M80ZE64**  
 VERSION : 1.0  
 PAGE : 4 of 5  
 DATE : FEB\_10 2011

Title		<Title>
Size	Document Number	Rev
B	USB-Blaster	<RevCode>
Date:	Monday, May 06, 2013	Sheet 5 of 7

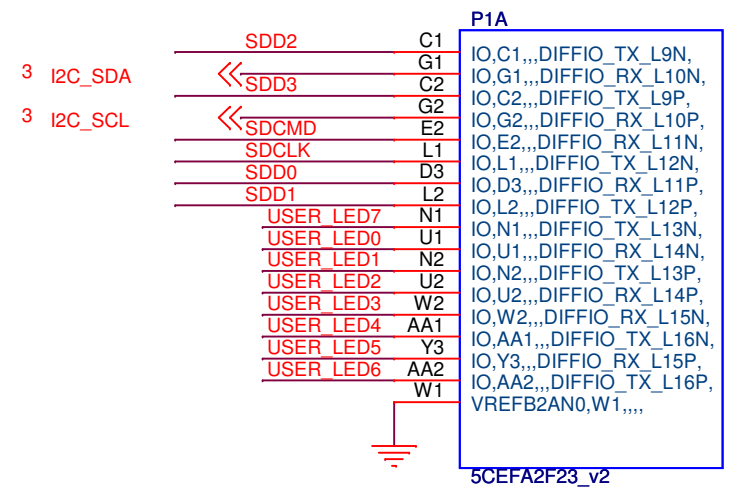
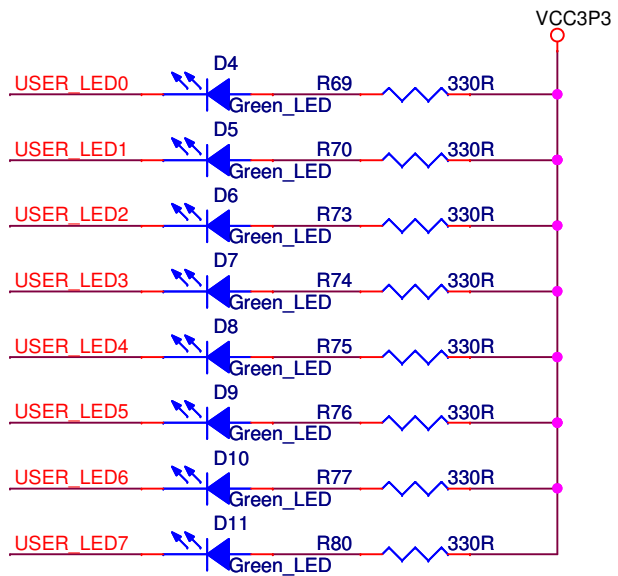

# microSD

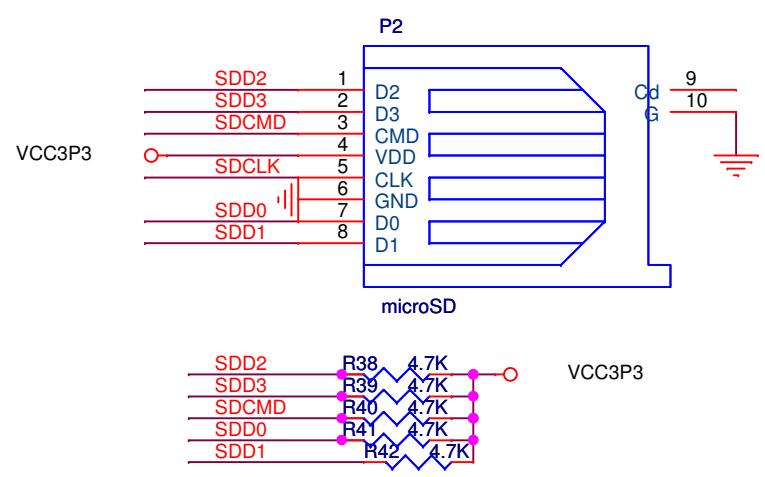

Title		
<Title>		
Size	Document Number	Rev
A	LED, EEPROM	<RevCode>
Date:	Thursday, April 25, 2013	Sheet 6 of 7

# ADP5052 (PACKWOOD)

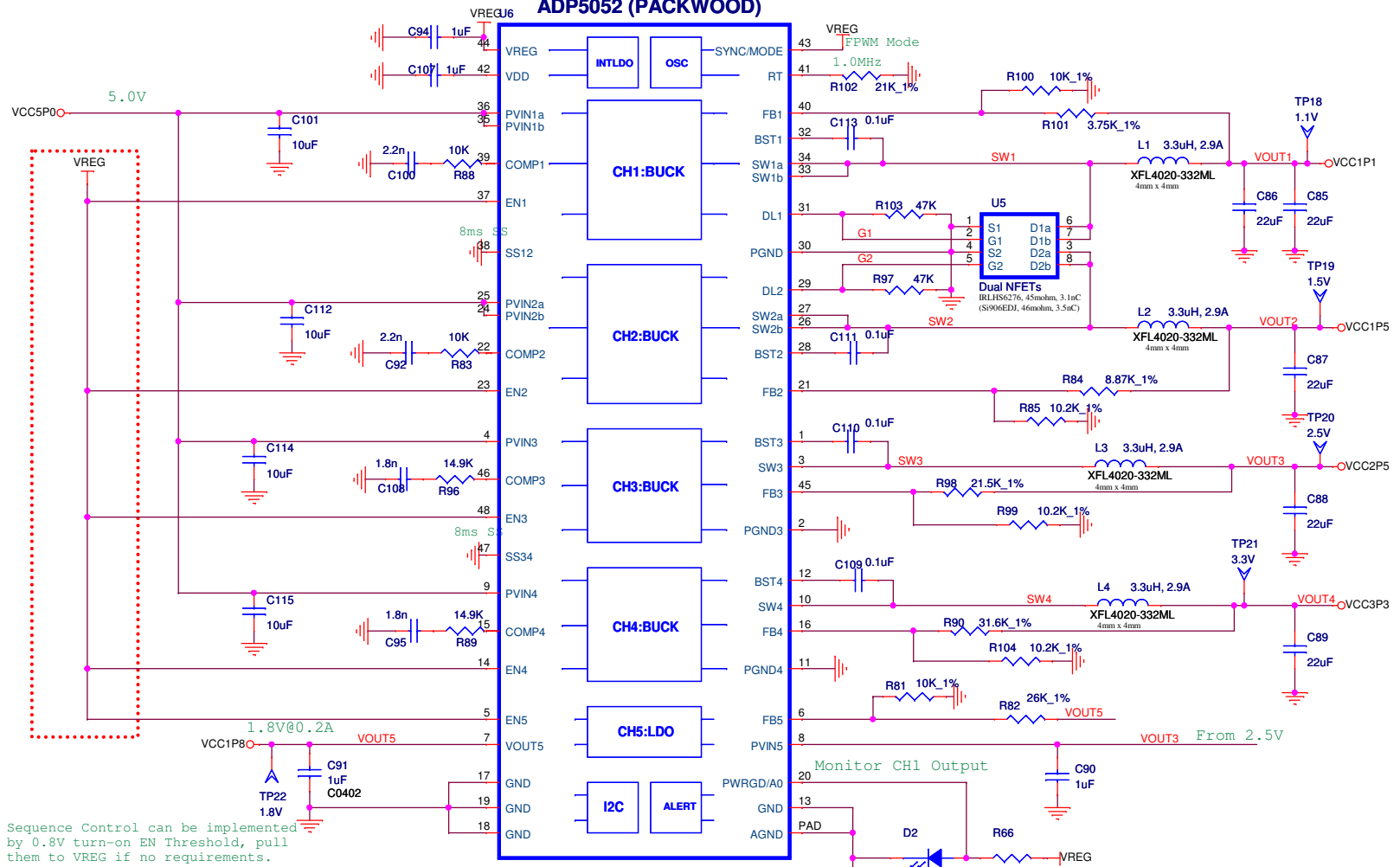

Sequence Control can be implemented by 0.8V turn-on EN Threshold, pull them to VREG if no requirements.

CAD Note:  
Place caps & res near regulator  
Place U38 at the same side as DDR3 addr/ctl/cmd termination resistor packs and capacitor arrays  
Pour copper on outer layer to cover these components

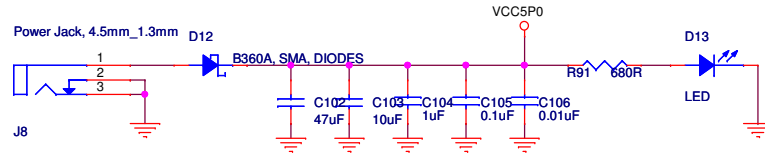
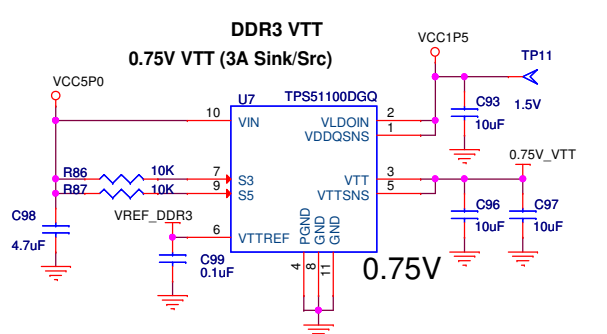

Title			<Title>
Size	Document Number	Rev	
B	Power	<RevCode>	
Date:	Thursday, April 25, 2013	Sheet	7 of 7