

Cooling Module Install Guide: Intel® Storage System SSR212MA

**A Guide for Technically Qualified Assemblers of Intel® Identified Subassemblies/
Products**

Intel Order Number: D23741-001



Disclaimer

Information in this document is provided in connection with Intel® products. No license, express or implied, by estoppel or otherwise, to any intellectual property rights is granted by this document. Except as provided in Intel's Terms and Conditions of Sale for such products, Intel assumes no liability whatsoever, and Intel disclaims any express or implied warranty, relating to sale and/or use of Intel® products including liability or warranties relating to fitness for a particular purpose, merchantability, or infringement of any patent, copyright or other intellectual property right. Intel products are not designed, intended or authorized for use in any medical, life saving, or life sustaining applications or for any other application in which the failure of the Intel product could create a situation where personal injury or death may occur. Intel may make changes to specifications and product descriptions at any time, without notice.

Intel® server boards contain a number of high-density VLSI and power delivery components that need adequate airflow for cooling. Intel's own chassis are designed and tested to meet the intended thermal requirements of these components when the fully integrated system is used together. It is the responsibility of the system integrator that chooses not to use Intel developed server building blocks to consult vendor datasheets and operating parameters to determine the amount of airflow required for their specific application and environmental conditions. Intel Corporation can not be held responsible if components fail or the server board does not operate correctly when used outside any of their published operating or non-operating limits.

Intel, Intel Pentium, and Intel Xeon are trademarks or registered trademarks of Intel Corporation or its subsidiaries in the United States and other countries.

* Other names and brands may be claimed as the property of others.

Copyright © 2005, Intel Corporation. All Rights Reserved

Safety Information

Important Safety Instructions

Read all caution and safety statements in this document before performing any of the instructions. See also Intel Server Boards and Server Chassis Safety Information on the *Intel® Server Deployment Toolkit CD* and/or at <http://support.intel.com/support/motherboards/server/sb/cs-010770.htm>.

Wichtige Sicherheitshinweise

Lesen Sie zunächst sämtliche Warnung und Sicherheitshinweise in diesem Dokument, bevor Sie eine der Anweisungen ausführen. Beachten Sie hierzu auch die Sicherheitshinweise zu Intel-Serverplatinen und Servergehäusen auf der *Intel® Server Deployment Toolkit CD* oder unter <http://support.intel.com/support/motherboards/server/sb/cs-010770.htm>.

Consignes de sécurité

Lisez attention toutes les consignes de sécurité et les mises en garde indiquées dans ce document avant de suivre toute instruction. Consultez Intel Server Boards and Server Chassis Safety Information sur le *Intel® Server Deployment Toolkit CD* ou bien rendez-vous sur le site <http://support.intel.com/support/motherboards/server/sb/cs-010770.htm>.

Instrucciones de seguridad importantes

Lea todas las declaraciones de seguridad y precaución de este documento antes de realizar cualquiera de las instrucciones. Vea Intel Server Boards and Server Chassis Safety Information en el *Intel® Server Deployment Toolkit CD* y/o en <http://support.intel.com/support/motherboards/server/sb/cs-010770.htm>.

重要安全指导

在执行任何指令之前，请阅读本文档中的所有注意事项及安全声明。和/或 <http://support.intel.com/support/motherboards/server/safecert.htm> 上的 *Intel Server Boards and Server Chassis Safety Information* (《Intel 服务器主板与服务器机箱安全信息》)。

Warnings

Heed safety instructions: Before working with your server product, whether you are using this guide or any other resource as a reference, pay close attention to the safety instructions. You must adhere to the assembly instructions in this guide to ensure and maintain compliance with existing product certifications and approvals. Use only the described, regulated components specified in this guide. Use of other products / components will void the UL listing and other regulatory approvals of the product and will most likely result in noncompliance with product regulations in the region(s) in which the product is sold.

System power on/off: The power button DOES NOT turn off the system AC power. To remove power from system, you must unplug the AC power cord from the wall outlet. Make sure the AC power cord is unplugged before you open the chassis, add, or remove any components.

Hazardous conditions, devices and cables: Hazardous electrical conditions may be present on power, telephone, and communication cables. Turn off the server and disconnect the power cord, telecommunications systems, networks, and modems attached to the server before opening it. Otherwise, personal injury or equipment damage can result.

Electrostatic discharge (ESD) and ESD protection: ESD can damage disk drives, boards, and other parts. We recommend that you perform all procedures in this chapter only at an ESD workstation. If one is not available, provide some ESD protection by wearing an antistatic wrist strap attached to chassis ground any unpainted metal surface on your server when handling parts.

ESD and handling boards: Always handle boards carefully. They can be extremely sensitive to ESD. Hold boards only by their edges. After removing a board from its protective wrapper or from the server, place the board component side up on a grounded, static free surface. Use a conductive foam pad if available but not the board wrapper. Do not slide board over any surface.

Installing or removing jumpers: A jumper is a small plastic encased conductor that slips over two jumper pins. Some jumpers have a small tab on top that you can grip with your fingertips or with a pair of fine needle nosed pliers. If your jumpers do not have such a tab, take care when using needle nosed pliers to remove or install a jumper; grip the narrow sides of the jumper with the pliers, never the wide sides. Gripping the wide sides can damage the contacts inside the jumper, causing intermittent problems with the function controlled by that jumper. Take care to grip with, but not squeeze, the pliers or other tool you use to remove a jumper, or you may bend or break the pins on the board.

Contents

Safety Information	iii
Important Safety Instructions	iii
Wichtige Sicherheitshinweise	iii
Consignes de sécurité	iii
Instrucciones de seguridad importantes	iii
Warnings.....	iv
Cooling Module Install Guide	1
Tools Needed	1
Kit Contents	1
Cooling Module Hot Swap Replacement Instructions	1
Prepare System	1
Open Enclosure Cover	2
Prepare Replacement Cooling Module	3
Remove Old Cooling Module	4
Install Replacement Cooling Module	5
Close Enclosure Cover	6

List of Figures

Figure 1. Accessing Cooling Module.....	2
Figure 2. Opening Cooling Module Latches.....	3
Figure 3. Replacement Cooling Module with Latches in Open Position.....	3
Figure 4. Unlatching Cooling Module from Chassis.....	4
Figure 5. Removing Cooling Module from Chassis.....	4
Figure 6. Inserting Cooling Module into Chassis.....	5
Figure 7. Closing Latches on Cooling Module.....	5
Figure 8. Closing Enclosure Cover.....	6

Cooling Module Install Guide

The Intel® Storage System SSR212MA ships with a cooling module that has three dual-rotor fans and two single-rotor fans mounted in a common frame for ease of maintenance. The cooling module is designed to be hot swappable; however, the replacement operation must be completed within 30 seconds to maintain proper cooling within the storage system.

Tools Needed

- Flat-head screwdriver

Kit Contents

Cooling Module Kit (FXSFANTRAY)

Item	Quantity
Cooling Module	1
Cooling Module Install Guide	1

Cooling Module Hot Swap Replacement Instructions

Prepare System

Note: The cooling module is located centrally within the Intel® Storage System SSR212MA. It is a hot swappable unit, but must be swapped out in less than 30 seconds to maintain proper cooling within the storage system. Before installing the replacement cooling module, inspect it for any visible signs of damage.

1. Read all caution and safety statements listed in this document before performing any of the steps. See the *Intel® Server Boards and Server Chassis Safety Information* document at <http://support.intel.com/support/motherboards/server/sb/cs-010770.htm> for a complete listing of all caution and safety statements.
2. Remove the cooling module from its protective packaging and place it next to the storage system for quick replacement.

Open Enclosure Cover

3. Release the lock (see letter “A” in the following figure) by turning the screw until the open lock symbol aligns with the notch in the cover. Press in on the palm latch (see letter “B”) and slide the enclosure cover back (see letter “C”) until it stops (about two inches), revealing the mounting brackets for the cooling module.

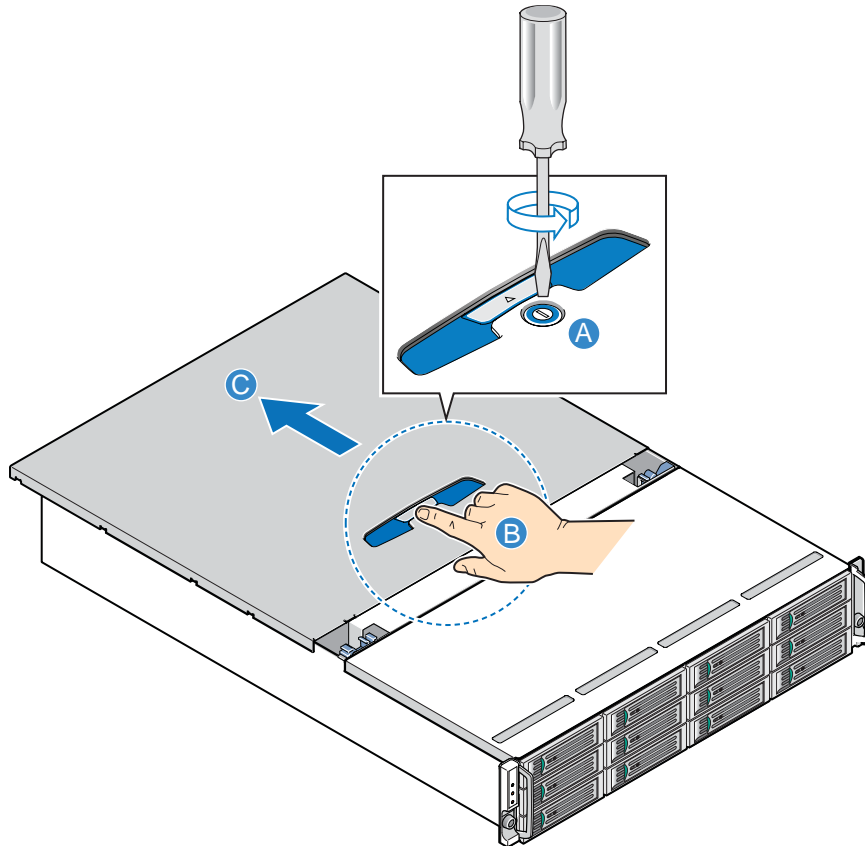

TP01851

Figure 1. Accessing Cooling Module

Prepare Replacement Cooling Module

4. Position the latches on the replacement cooling module in the open position (see letter “A” in the following figure).

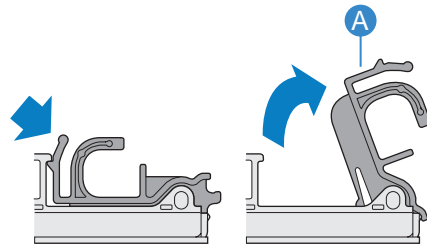

TP01852

Figure 2. Opening Cooling Module Latches

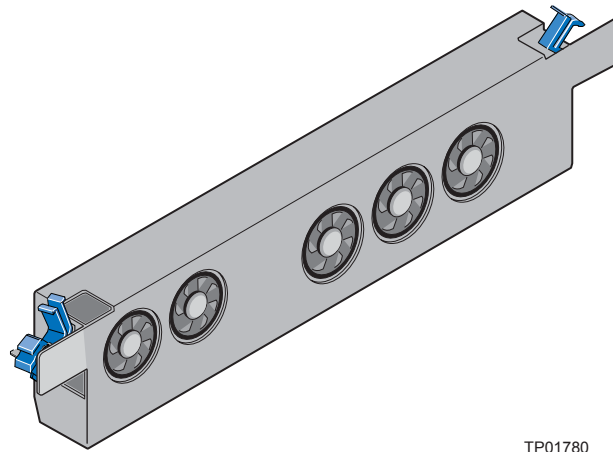

TP01780

Figure 3. Replacement Cooling Module with Latches in Open Position

Remove Old Cooling Module

5. Rotate the two latches on the old cooling module to the open position.

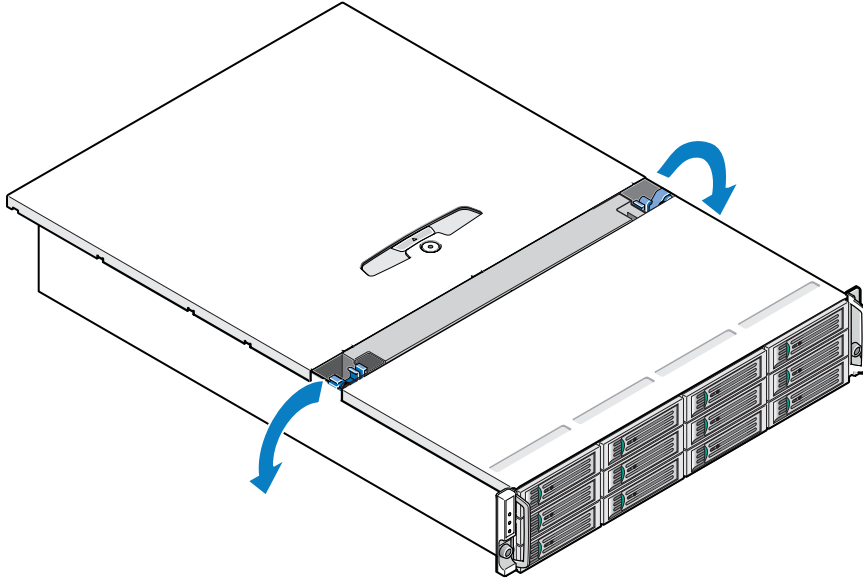

TP01860

Figure 4. Unlatching Cooling Module from Chassis

6. With the two latches in the open position, slide the old cooling module out of the storage system.

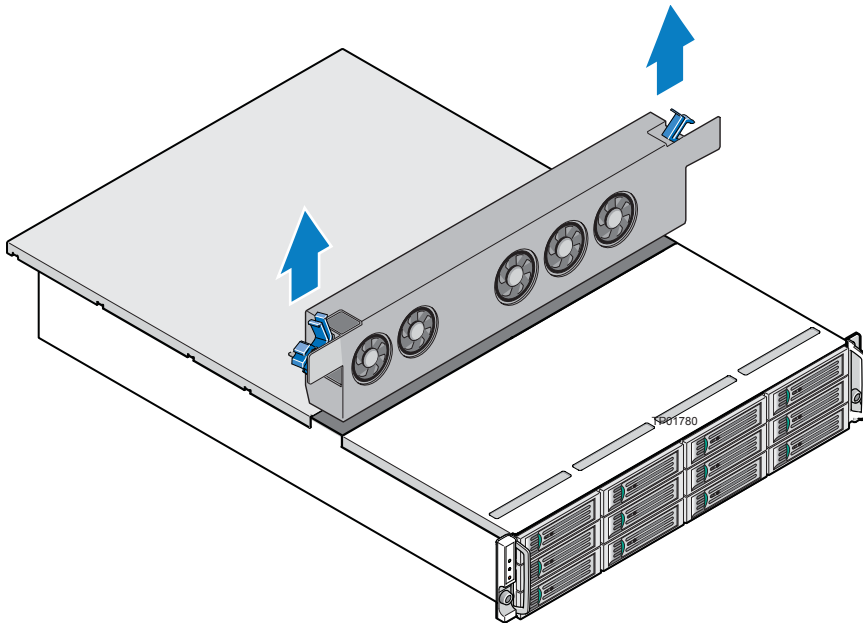

TP01858

Figure 5. Removing Cooling Module from Chassis

Install Replacement Cooling Module

7. With the two latches in the open position, slide the replacement cooling module into the storage system until the latches engage automatically.

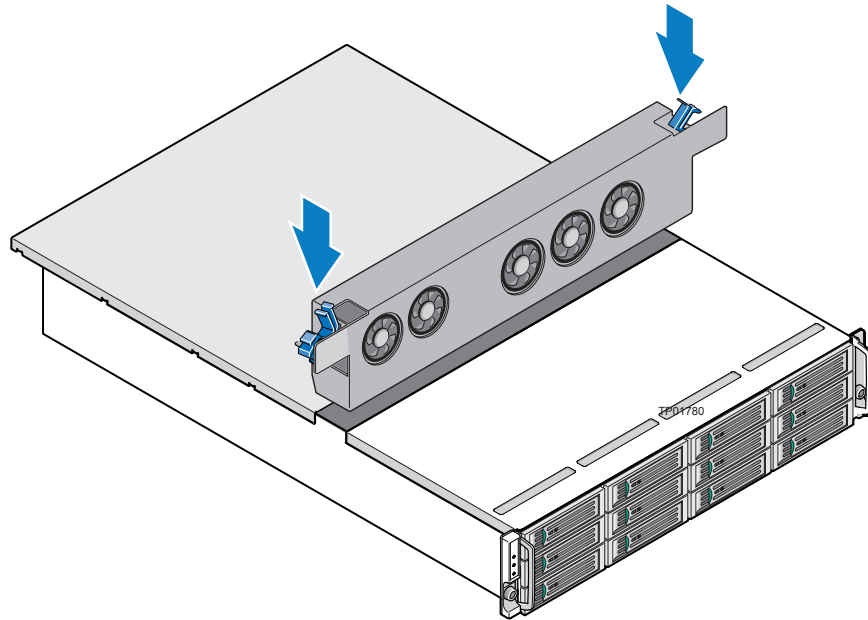

TP01859

Figure 6. Inserting Cooling Module into Chassis

8. Cam the replacement cooling module home by manually closing the latches. A click should be heard as the latches engage.

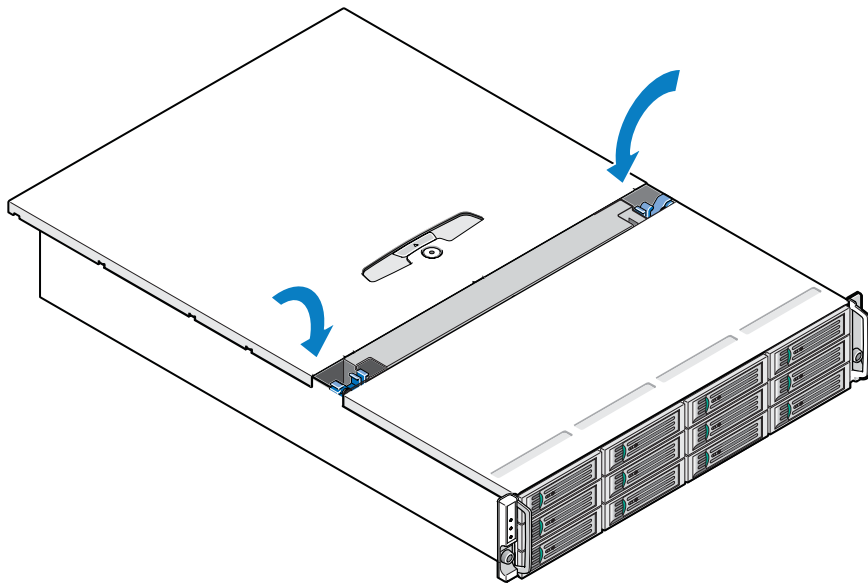

TP01861

Figure 7. Closing Latches on Cooling Module

Close Enclosure Cover

9. Close the enclosure cover by sliding it forward (see letter “A” in the following figure). Secure the enclosure cover to the chassis by tightening the lock with a screwdriver (see letter “B”) until the close latch symbol aligns with the notch on the cover.

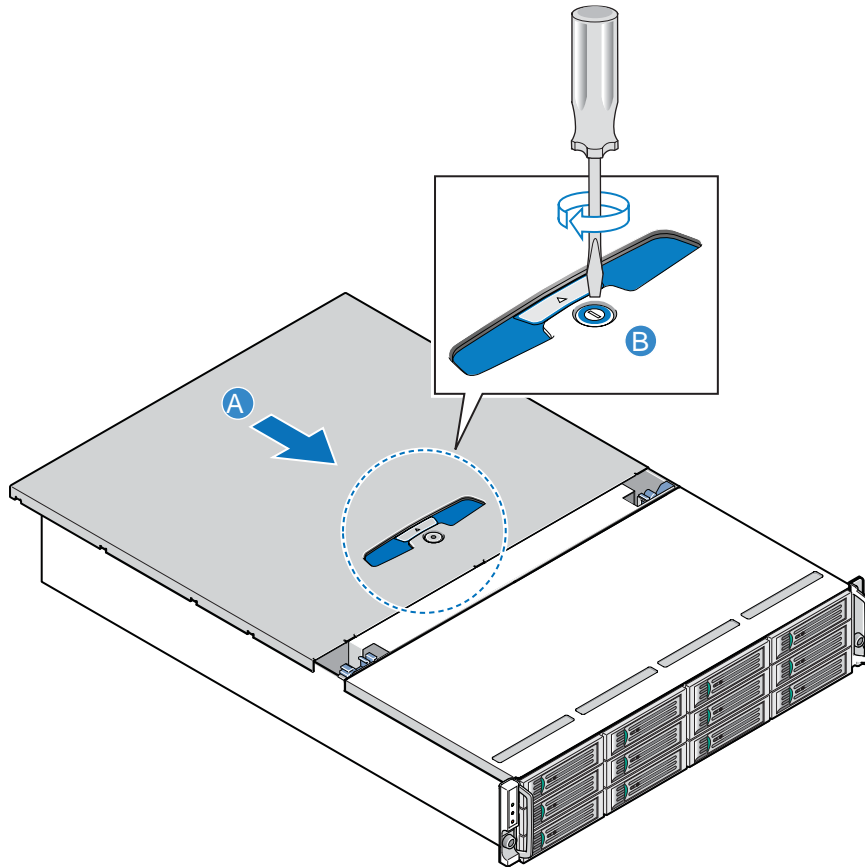

TP01773

Figure 8. Closing Enclosure Cover