

7 Install DIMM Memory Modules

DDR3 DIMM Memory Identification:

CAUTION: Observe normal ESD (ElectroStatic Discharge) procedures to avoid possible damage to system components.

This server board supports up to 16 DDR3 800/1066/1333/1600 UDIMM/RDIMM/LRDIMM.

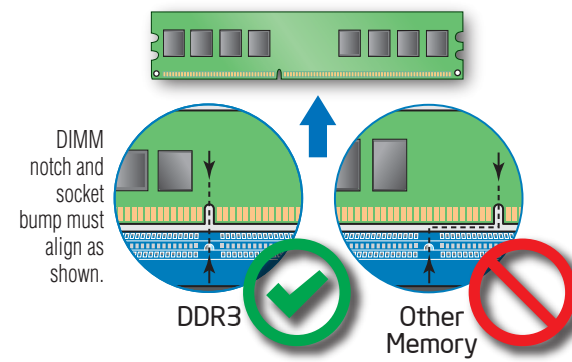

Memory Configurations and Population Order:

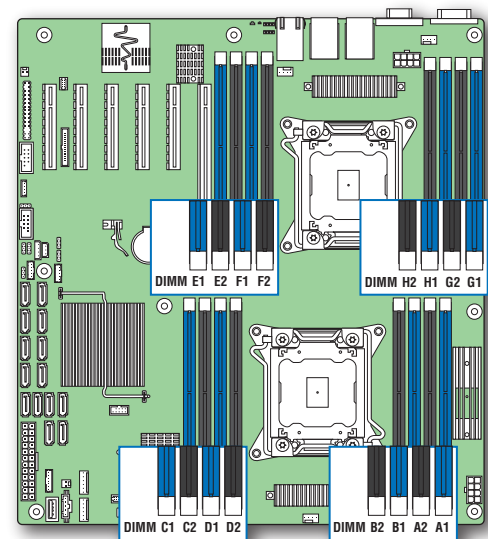

Memory Type: Minimum of one 1 GB, DDR3 800/1066/1333/1600 MHz UDIMM/RDIMM/LRDIMM.

Note: For additional memory configurations, see the Technical Product Specification for Intel® Server Board S2600CP at: <http://www.intel.com/support/motherboards/server>.

Memory sizing and configuration is supported only for qualified DIMMs approved by Intel®.

8 Make Server Board Power Connections

- A Attach the CPU 1 power connector.
- B Attach the CPU 2 power connector.
- C Attach the main power connector.

CAUTION: Note the location of the latch on each power cable connector and align it with the matching tab on each server board socket.

IMPORTANT NOTE: If you are using a non-Intel server chassis with an ATX power supply, see the documentation that came with your chassis for installation information.

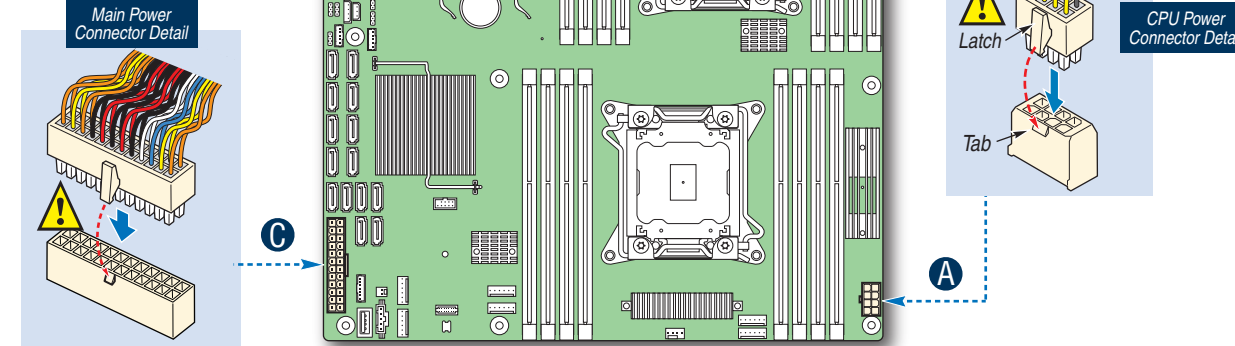

9 Install Optical Drive and Hard Drive(s)

See the documentation that came with your server chassis for drive installation.

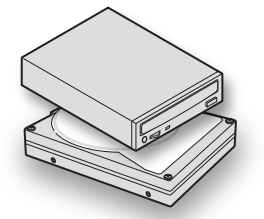

10 Install Intel® RAID C600 Upgrade Key (Optional)

Locate the white 4-pin key header between Serial B port and Front Panel USB port. Match the Key and connector orientation and press down to install.

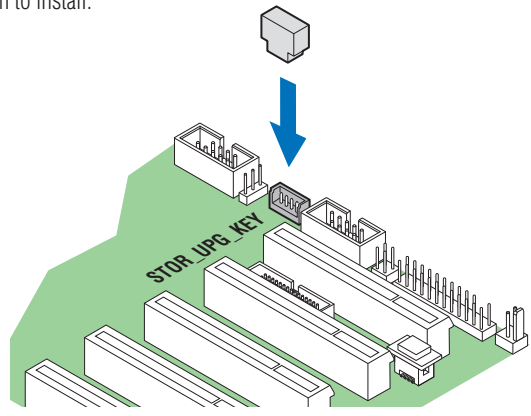

11 Connect Hard Drives/Optical Drive to Server Board

Connect SAS/SATA Data Cables to server board here.

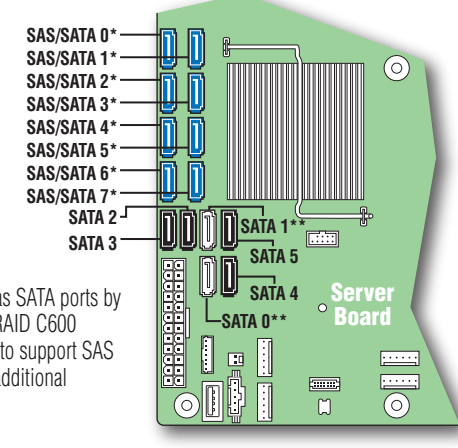

NOTE:
 * Ports 0-3 are enabled as SATA ports by default. Optional Intel® RAID C600 Upgrade Key is required to support SAS feature on ports 0-3, or additional SATA/SAS ports 4-7.
 ** 6Gb/s SATA port.

12 Attach Front Panel, Serial, and USB Connections

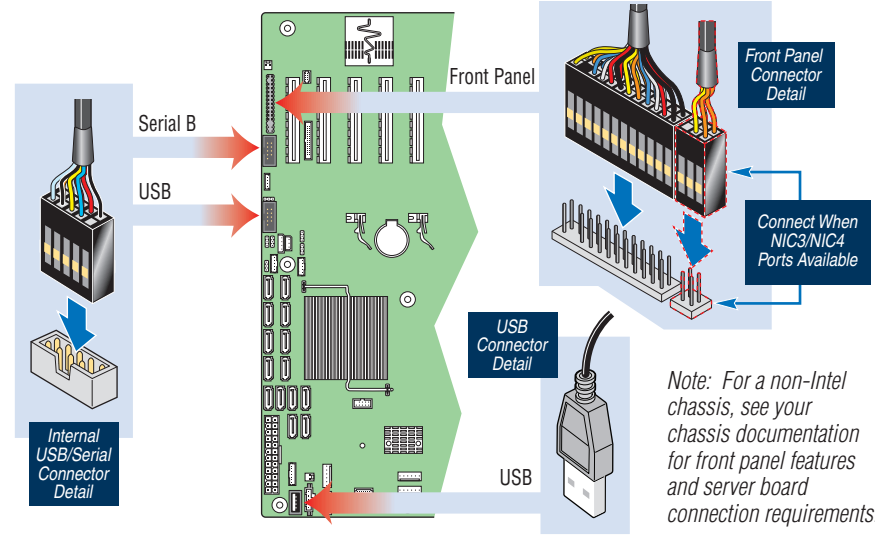

Note: For a non-Intel chassis, see your chassis documentation for front panel features and server board connection requirements.

13 Chassis Fan Connections

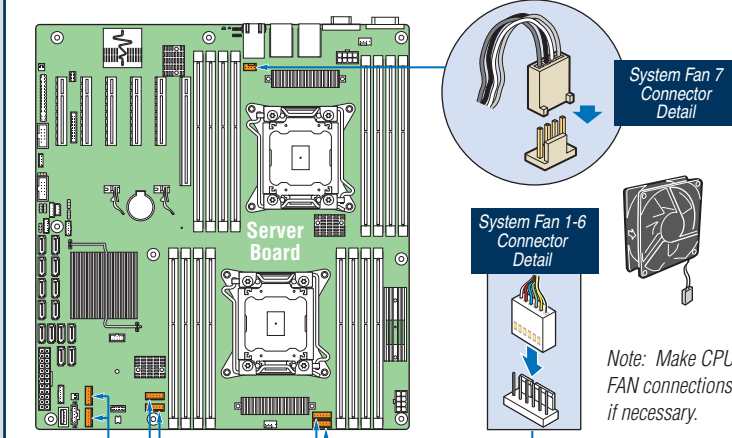

For a non-Intel server chassis, see the documentation accompanying your chassis for specific chassis fan connection requirements. Refer to the "Making Connections to the Server Board - Quick Reference" section below.

14 Install TPM, RMM4 and eUSB SSD (Optional)

See the Intel® Trusted Platform Module Hardware User's Guide for the TPM module installation.

See Intel® Remote Management Module 4 User Guide for the RMM4 installation.

See the instructions come along with the eUSB SSD device for eUSB SSD installation.

15 Install Add-in Card (Optional)

See the documentation that came with your server chassis for add-in card installation. For the Intel® Server Chassis P4000 series, see the Quick Installation User's Guide accompanying the chassis.

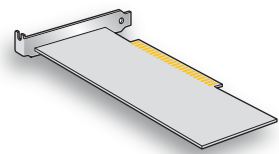

16 Finishing Up

Before installing your operating system, you must finish your chassis installation, make I/O connections and plug in AC power.

See your chassis documentation for AC power and grounding requirements.

CAUTION: See your chassis documentation for AC power and grounding requirements.

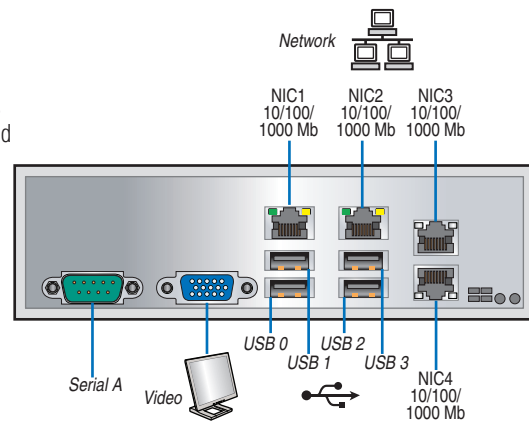

17 Software • BIOS, Drivers, and Operating System Installation

- A. Confirm BIOS Version:** Look on the Server/System Management screen in the BIOS Setup Utility to determine the installed BIOS version. Compare this to the versions at: <http://www.intel.com/support/motherboards/server>. If new versions are available, update the BIOS on your server.
- B. Configure your RAID Controller:** Use the instructions provided with the RAID controller.
- C. Install your Operating System:** Use the instructions provided with the RAID controller and with the operating system.
- D. Install Operating System Drivers:** With the operating system running, insert the Intel® Server Deployment and Management DVD. If using a Microsoft Windows® operating system, the Intel® Deployment Assistant will autorun and allow you to select the appropriate drivers to install. On other operating systems, browse the DVD folders to locate and install the driver files.

Common Problems and Solutions

For a list of hardware components that have been tested with this system, see: <http://www.intel.com/support/motherboards/server>

- The system does not boot or show video at power-on.
 - Check that the +12V CPU power connector is plugged in. Without this cable, the processors will not have any power.
 - Only Intel® Xeon® Processor E5-2600 series with 130 W and less Thermal Design Power (TDP) are supported on this server board. Previous generation Intel® Xeon® processors are not supported.
 - Beep code 1-5-2-1 in a system means you do not have Intel® Xeon® Processor E5-2600 series installed.
- The system generates the memory error beep code and POST diagnostic LED message (0XE0-0XE7) that indicates memory errors in early POST.
 - Remember, all DIMMs must be:
 - DDR3 800/1066/1333/1600 MHz UDIMM/RDIMM/LRDIMM.
 - From the same manufacturer.
 - Installed beginning with DIMM A1.

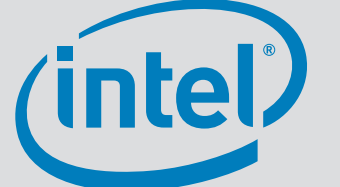

Making Connections to the Server Board — Quick Reference

Required Connections		Intel® Server Chassis P4000 series
A. CPU 1-2 Power Connector		■
B. Main Power Connector		■
C. Front Panel Header		■
Optional Connections		Intel® Server Chassis P4000 series
D. System Fan 1 Header		■
E. System Fan 2 Header		■
F. System Fan 3 Header		■
G. System Fan 4 Header		■
H. System Fan 5 Header		■
I. System Fan 6 Header		■
J. System Fan 7 Header		■
K. CPU 1 Fan Header		■
L. CPU 2 Fan Header		■
M. Serial B		■
N. Storage Upgrade Key		■
O. USB (Front Panel)		■
P. IPMB		■
Q. SAS/SATA Connectors		■
R1. SATA 6G R2. SATA 3G		■
S. RMM4 Lite		■
T. Chassis Intrusion		■
U. RMM4 NIC		■
V. HSBP_I2C		■
W. SAS_SGPIIO		■
X. SATA_SGPIIO		■
Y. eUSB SSD		■
Z. TPM		■
AA. USB (Type A)		■
AB. LCP		■
AC. PMBus		■

- Make the connections with fixed fans
- Make the connections with hotswap fans, backplane(s), power supply(s)
- Make the connection when applicable

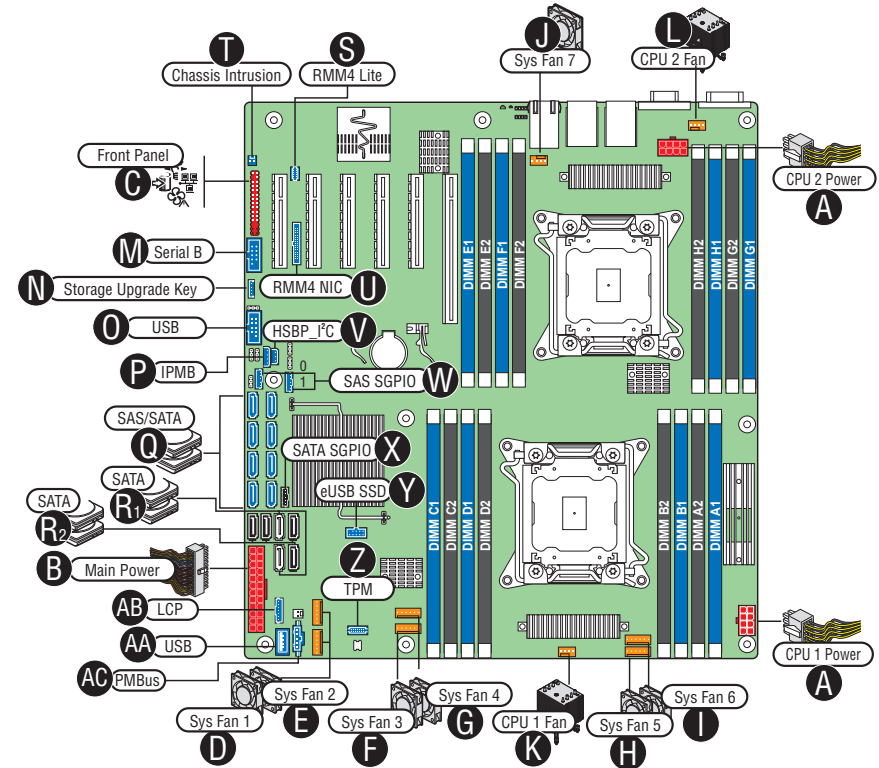

Note: For a non-Intel Chassis, see your chassis documentation for server board connection information.

Note: Not all optional connections are shown in this diagram. Refer to your Server Board Service Guide, and your server chassis documentation for additional connection information.

IMPORTANT Note: Cables should be tied for better airflow. Use cable-ties as necessary.

Cable Routing with Fixed Fans, Fixed HDDs, Fixed PSU

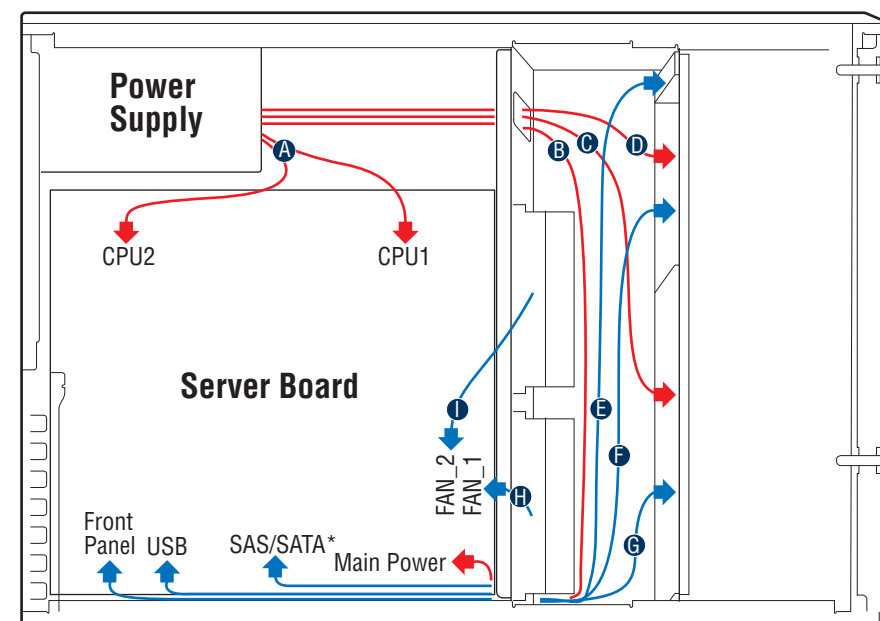

- A CPU1/CPU2 Power Cable
- B Server Board Main Power Cable
- C Fixed HDD Power Cable
- D ODD Power Cable
- E Front Panel Cable, USB Cable
- F ODD Data Cable (Connect To White Backplane)
- G SATA 6G Connectors On Server Board)
- H Fixed HDD Data Cable
- I System FAN 1
- J System FAN 2

Cable Routing with Hotswap Fans, backplane(s), redundant PSU(s)

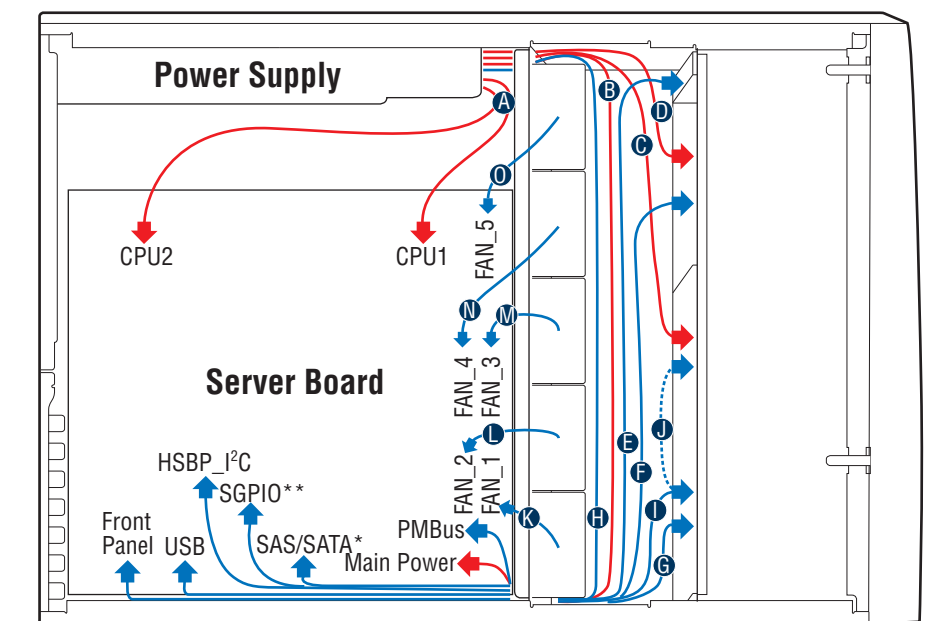

- A CPU1/CPU2 Power Cable
- B Server Board Main Power Cable
- C Backplane Power Cable
- D ODD Power Cable
- E Front Panel Cable, USB Cable
- F ODD Data Cable (Connect To White SATA 6G Connectors On Server Board)
- G MiniSAS and SGPIIO
- H PMBus Cable
- I HSBP_I2C Cable (From Server Board To First Backplane)
- J HSBP_I2C Cable (From First Backplane To Second Backplane when Second Backplane Available)
- K System FAN 1
- L System FAN 2
- M System FAN 3
- N System FAN 4
- O System FAN 5