

Intel® Storage System JBOD 2000 Family Quick Installation User's Guide

A Guide for Technically Qualified Assemblers of Intel® identified Subassemblies/Products

Order Number: G84193-001

G84193-001 

Disclaimer

INFORMATION IN THIS DOCUMENT IS PROVIDED IN CONNECTION WITH INTEL® PRODUCTS. NO LICENSE, EXPRESS OR IMPLIED, BY ESTOPPEL OR OTHERWISE, TO ANY INTELLECTUAL PROPERTY RIGHTS IS GRANTED BY THIS DOCUMENT. EXCEPT AS PROVIDED IN INTEL®S TERMS AND CONDITIONS OF SALE FOR SUCH PRODUCTS, INTEL® ASSUMES NO LIABILITY WHATSOEVER AND INTEL® DISCLAIMS ANY EXPRESS OR IMPLIED WARRANTY, RELATING TO SALE AND/OR USE OF INTEL® PRODUCTS INCLUDING LIABILITY OR WARRANTIES RELATING TO FITNESS FOR A PARTICULAR PURPOSE, MERCHANTABILITY, OR INFRINGEMENT OF ANY PATENT, COPYRIGHT OR OTHER INTELLECTUAL PROPERTY RIGHT.

A "Mission Critical Application" is any application in which failure of the Intel® Product could result, directly or indirectly, in personal injury or death. SHOULD YOU PURCHASE OR USE INTEL®S PRODUCTS FOR ANY SUCH MISSION CRITICAL APPLICATION, YOU SHALL INDEMNIFY AND HOLD INTEL® AND ITS SUBSIDIARIES, SUBCONTRACTORS AND AFFILIATES, AND THE DIRECTORS, OFFICERS, AND EMPLOYEES OF EACH, HARMLESS AGAINST ALL CLAIMS COSTS, DAMAGES, AND EXPENSES AND REASONABLE ATTORNEYS' FEES ARISING OUT OF, DIRECTLY OR INDIRECTLY, ANY CLAIM OF PRODUCT LIABILITY, PERSONAL INJURY, OR DEATH ARISING IN ANY WAY OUT OF SUCH MISSION CRITICAL APPLICATION, WHETHER OR NOT INTEL® OR ITS SUBCONTRACTOR WAS NEGLIGENT IN THE DESIGN, MANUFACTURE, OR WARNING OF THE INTEL® PRODUCT OR ANY OF ITS PARTS.

Intel® may make changes to specifications and product descriptions at any time, without notice. Designers must not rely on the absence or characteristics of any features or instructions marked "reserved" or "undefined". Intel® reserves these for future definition and shall have no responsibility whatsoever for conflicts or incompatibilities arising from future changes to them. The information here is subject to change without notice. Do not finalize a design with this information.

The products described in this document may contain design defects or errors known as errata which may cause the product to deviate from published specifications. Current characterized errata are available on request.

Contact your local Intel® sales office or your distributor to obtain the latest specifications and before placing your product order.

Copies of documents which have an order number and are referenced in this document, or other Intel® literature, may be obtained by calling 1-800-548-4725, or go to: <http://www.intel.com/design/literature>.

Table of Contents

Safety Information	v
General Installation Process	1
Before You Begin	2
Tools and Supplies needed	2
System Reference	2
Cable Routing	2
Installing a Hot-swap Hard Disk Drive	2
Installing a Hard Disk Drive into 3.5" Hard Drive Carrier	3
Installing a Hard Disk Drive into 2.5" Hard Drive Carrier	5
Installing Second Power Supply Module (Optional)	6
Installing the Rack Handles	7
Finishing Up	8
Warranty Information	9

List of Figures

Figure 1. Installing Hard Disk Drive – Removing 3.5” HDD carrier	3
Figure 2. Installing Hard Disk Drive – Removing 3.5” HDD interface bracket.....	3
Figure 3. Installing Hard Disk Drive – Installing 3.5” HDD	3
Figure 4. Installing Hard Disk Drive – Installing 2.5” HDD	4
Figure 5. Installing Hard Disk Drive – Inserting 3.5” HDD assembly	4
Figure 6. Installing Hard Disk Drive – Removing 2.5” HDD carrier	5
Figure 7. Installing Hard Disk Drive – Removing plastic drive blank	5
Figure 8. Installing Hard Disk Drive – Installing 2.5” HDD	5
Figure 9. Installing Hard Disk Drive – Inserting 2.5” HDD assembly	6
Figure 10. Removing the filler panel	6
Figure 11. Installing the power supply module.....	6
Figure 12. Removing the power supply module	7
Figure 13. Installing the Rack Hand	7
Figure 14. Connecting Intel® Storage System JBOD 2000 Family to RAID controller.....	8

Safety Information

Important Safety Instructions

Read all caution and safety statements in this document before performing any of the instructions. See also Intel® Server Boards and Server Chassis Safety Information on the Intel® Server Deployment Toolkit 3.0 CD and/or at <http://www.intel.com/support/motherboards/server/sb/cs-010770.htm>.

Wichtige Sicherheitshinweise

Lesen Sie zunächst sämtliche Warnung und Sicherheitshinweise in diesem Dokument, bevor Sie eine der Anweisungen ausführen. Beachten Sie hierzu auch die Sicherheitshinweise zu Intel®-Serverplatinen und Servergehäusen auf der Intel® Server Deployment Toolkit 3.0 CD oder unter <http://www.intel.com/support/motherboards/server/sb/cs-010770.htm>.

Consignes de sécurité

Lisez attention toutes les consignes de sécurité et les mises en garde indiquées dans ce document avant de suivre toute instruction. Consultez Intel® Server Boards and Server Chassis Safety Information sur le Intel® Server Deployment Toolkit 3.0 CD ou bien rendez-vous sur le site <http://www.intel.com/support/motherboards/server/sb/cs-010770.htm>.

Instrucciones de seguridad importantes

Lea todas las declaraciones de seguridad y precaución de este documento antes de realizar cualquiera de las instrucciones. Vea Intel® Server Boards and Server Chassis Safety Information en el Intel® Server Deployment Toolkit 3.0 CD y/o en <http://www.intel.com/support/motherboards/server/sb/cs-010770.htm>.

重要安全指导

在执行任何指令之前，请阅读本文档中的所有注意事项及安全声明。和/或 <http://www.intel.com/support/motherboards/server/sb/cs-010770.htm> 上的 *Intel® Server Boards and Server Chassis Safety Information*（《Intel 服务器主板与服务器机箱安全信息》）。

Warnings

Heed safety instructions: Before working with your product, whether you are using this guide or any other resource as a reference, pay close attention to the safety instructions. You must adhere to the assembly instructions in this guide to ensure and maintain compliance with existing product certifications and approvals. Use only the described, regulated components specified in this guide. Use of other products/components will void the UL listing and other regulatory approvals of the product and will most likely result in noncompliance with product regulations in the region(s) in which the product is sold.

System power on/off: The power button DOES NOT turn off the system AC power. To remove power from the system, you must unplug the AC power cord from the wall outlet. Make sure the AC power cord is unplugged before you open the chassis, add, or remove any components.

Hazardous conditions, devices and cables: Hazardous electrical conditions may be present on power, telephone, and communication cables. Turn off the server and disconnect the power cord, telecommunications systems, networks, and modems attached to the server before opening it. Otherwise, personal injury or equipment damage can result.

ElectroStatic Discharge (ESD) and ESD protection: ESD can damage disk drives, boards, and other parts. We recommend that you perform all the procedures in this chapter only at an ESD workstation. If one is not available, provide some ESD protection by wearing an antistatic wrist strap attached to chassis ground - any unpainted metal surface - on your server when handling the parts.

ESD and handling boards: Always handle boards carefully. They can be extremely sensitive to ESD. Hold boards only by their edges. After removing a board from its protective wrapper or from the server, place the board component side up on a grounded, static free surface. Use a conductive foam pad if available but not the board wrapper. Do not slide board over any surface.

General Installation Process

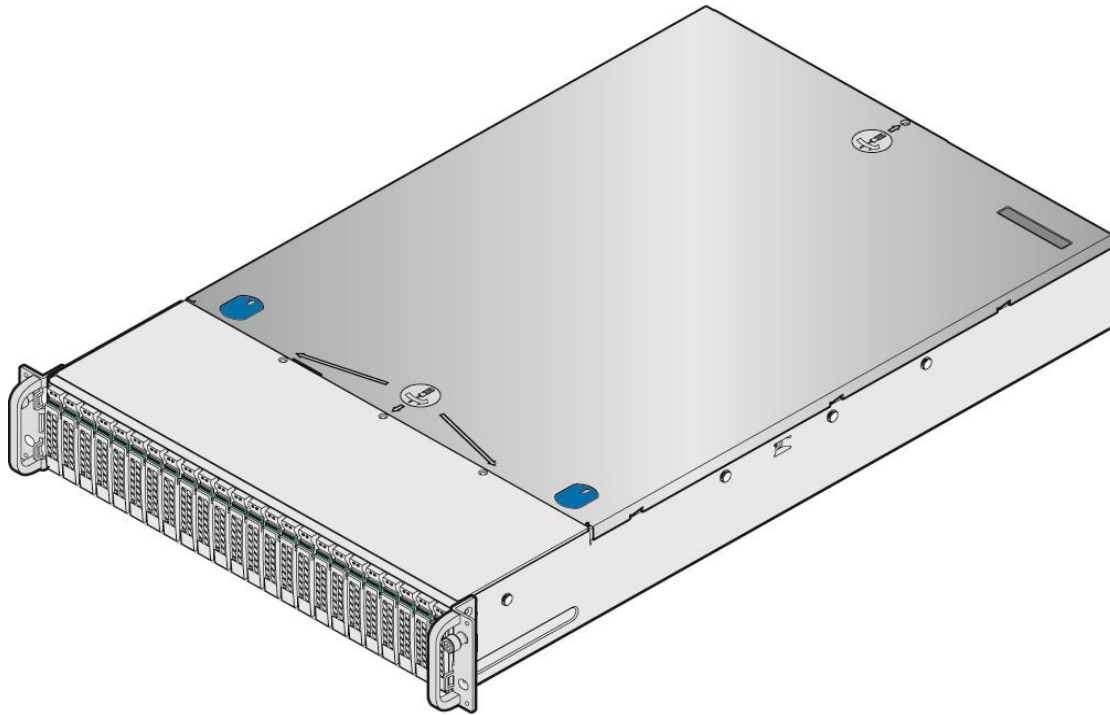

AF006035

*** 2.5" hard drive bay system as shown**

Before You Begin

Before working with your server product, pay close attention to the [Safety Information](#) at the beginning of this manual.

Note: Whenever you service the system, you must first power down the server and unplug all peripheral devices and the power cord.

Tools and Supplies needed

- Phillips* (cross head) screwdriver (#2 bit)
- Needle nosed pliers
- Anti-static wrist strap and conductive foam pad (recommended)

System Reference

All references to left, right, front, top, and bottom assume the reader is facing the front of the chassis as it would be positioned for normal operation.

Cable Routing

When you add or remove components from your server system, make sure your cables are routed correctly before reinstalling the server system cover. Use caution to make sure no cables or wires are pinched and that the airflow from the fans is not blocked. Use the figures below to determine the correct cable routing.

Note: Red lines are for power connection, dot lines are for optional device connection.

Installing a Hot-swap Hard Disk Drive

Caution: If you do not install all drives, empty drive bays must be occupied by carriers with plastic drive blank provided to maintain proper system cooling.

Installing a Hard Disk Drive into 3.5” Hard Drive Carrier

1. Remove the drive carrier by pressing the green button and opening the lever (see letter **A**). Slide the carrier out (see letter **B**).

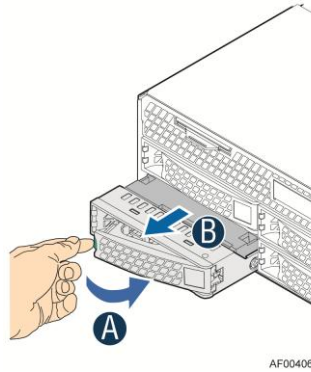

Figure 1. Installing Hard Disk Drive – Removing 3.5” HDD carrier

2. Remove the four screws securing the HDD interface bracket and remove the HDD interface bracket (see letter **C**).

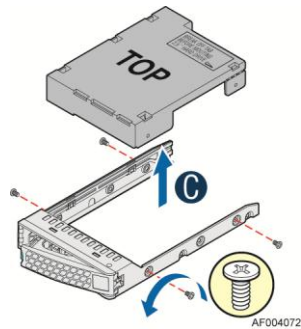

Figure 2. Installing Hard Disk Drive – Removing 3.5” HDD interface bracket

3. Install the hard disk drive using the same four screws as shown. Make sure the connector end of the drive matches the backplane connector (see letter **D**).

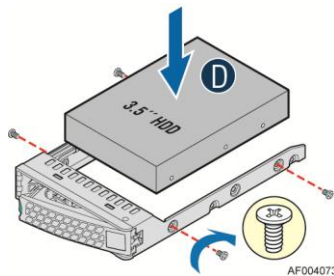

Figure 3. Installing Hard Disk Drive – Installing 3.5” HDD

For installing 2.5" Hard Disk Drive as an option:

- A. Break off the tab on the HDD interface bracket (see letter **d1**).
- B. Install the HDD interface bracket from top.
- C. Secure the bracket with three screws as shown (see letter **d2**).
- D. Slide the 2.5" HDD into the bracket to align the screw holes with the right and left rail (see letter **d3**).
- E. Secure the hard disk drive using the four screws for 2.5" HDD (see letter **d4**).

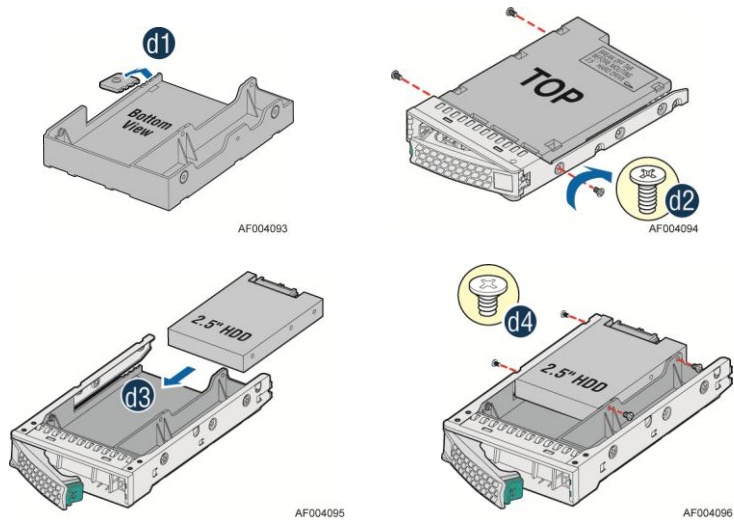

Figure 4. Installing Hard Disk Drive – Installing 2.5" HDD

- 4. With the lever open, insert the hard disk drive assembly into the chassis (see letter **E**). Push in the lever to lock it into place (see letter **F**).

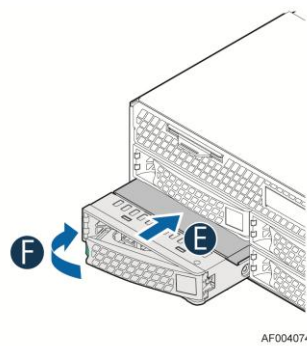

Figure 5. Installing Hard Disk Drive – Inserting 3.5" HDD assembly

Installing a Hard Disk Drive into 2.5" Hard Drive Carrier

1. Remove the drive carrier by pressing the green latch to unlock (see letter **A**). Pull out the black lever and slide the carrier out (see letter **B**).

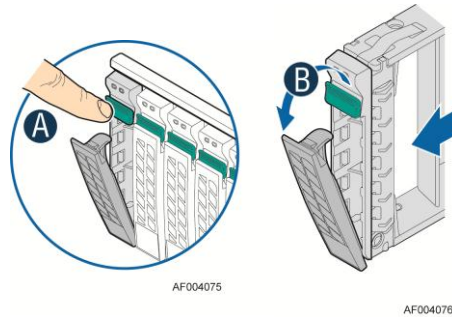

Figure 6. Installing Hard Disk Drive – Removing 2.5" HDD carrier

2. Remove the four screws securing the plastic drive blank from the 2.5" HDD carrier (see letter **C**). Disengage the plastic drive blank from the HDD carrier. Remove the plastic drive blank from the 2.5" HDD carrier (see letter **D**).

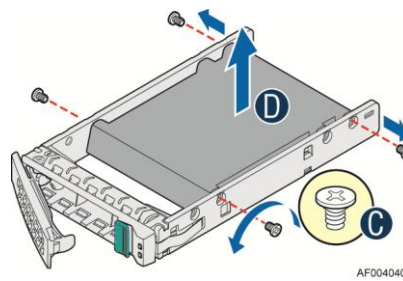

Figure 7. Installing Hard Disk Drive – Removing plastic drive blank

3. Install the hard disk drive using the four screws as shown. Make sure the connector end of the drive matches the backplane connector (see letter **E**).

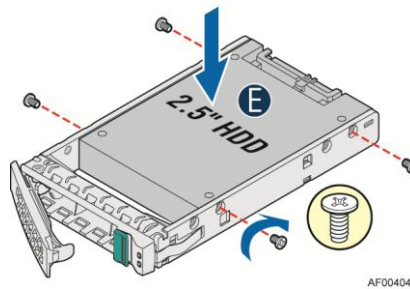

Figure 8. Installing Hard Disk Drive – Installing 2.5" HDD

4. With the lever open, insert the hard disk drive assembly into the chassis, then push in the lever to lock it into place (see letter **F**).

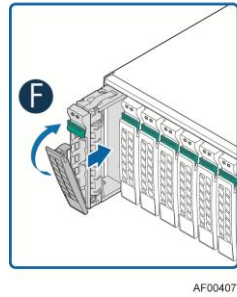

Figure 9. Installing Hard Disk Drive – Inserting 2.5” HDD assembly

Installing Second Power Supply Module (Optional)

1. Use the 'finger hole' to remove the filler panel.

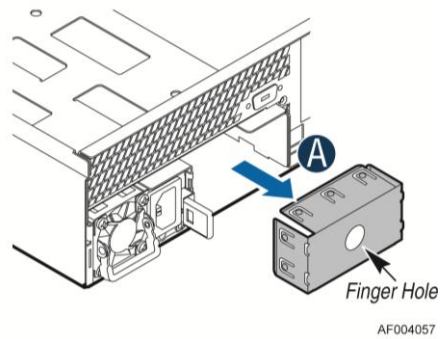

Figure 10. Removing the filler panel

2. Insert the power supply module into the power supply cage and push all the way until it clicks into place.

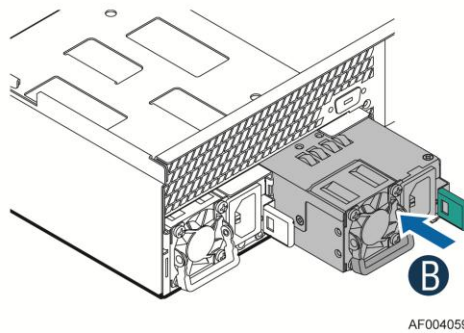

Figure 11. Installing the power supply module

Note: To remove a power supply module, push the green latch in the direction shown while pulling out of the system by the handle.

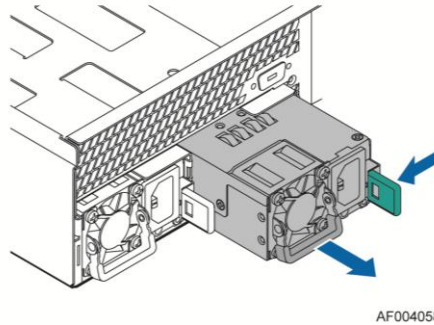

Figure 12. Removing the power supply module

Installing the Rack Handles

Note: Rack handles are required to install the bezel. For detailed instructions, see the Service Guide.

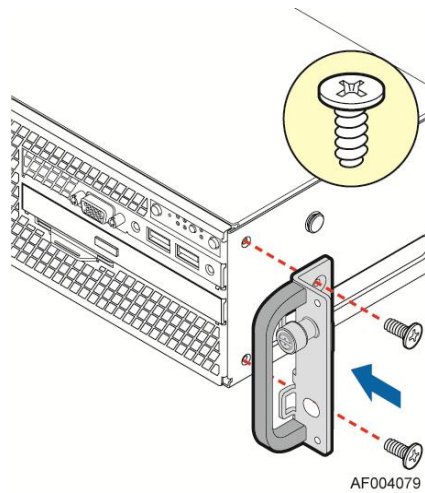

Figure 13. Installing the Rack Hand

Finishing Up

Before using this Intel® Storage System JBOD 2000 Family, you must finish making I/O connections and plug in the power cord(s).

1. Verify that the system top cover is installed.
2. Install the server into the rack using the instructions provided with the rack mounting kit.
3. Connect the Intel® Storage System JBOD 2000 Family system to your RAID controller external mini SAS port with the correct cable.
4. Connect the power cord(s).

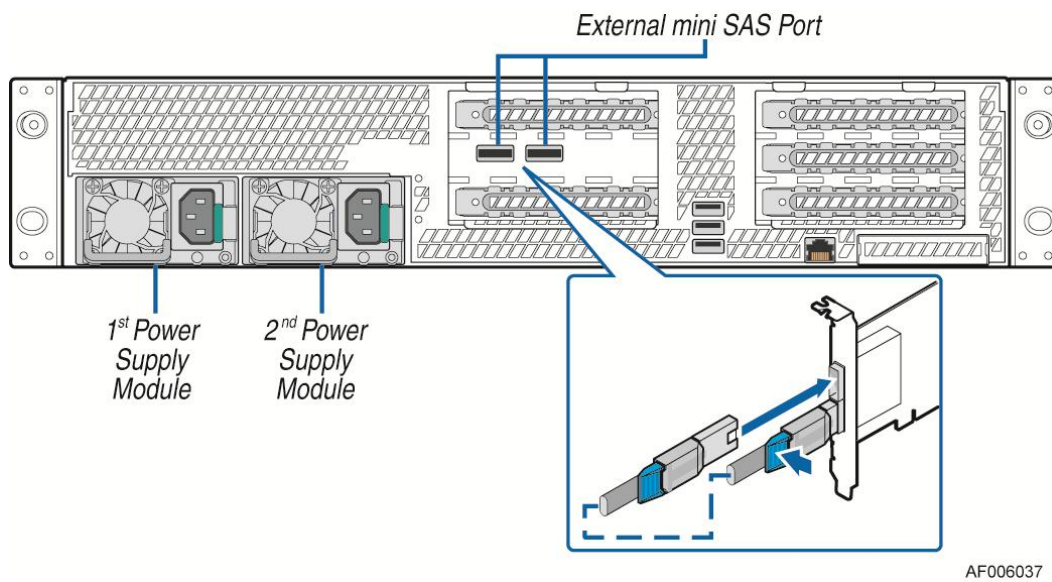

Figure 14. Connecting Intel® Storage System JBOD 2000 Family to RAID controller

Warranty Information

To obtain warranty information, visit the following Intel® website:

http://www.intel.com/p/en_US/support/warranty