



Mobile Intel[®] Pentium[®] 4 Processor with 533 MHz System Bus

Specification Update

January 2006

Notice: The Mobile Intel[®] Pentium[®] 4 processor with 533 MHz system bus may contain design defects or errors known as errata which may cause the product to deviate from published specifications. Current characterized errata are documented in this Specification Update.

Document Number: [253176-022](#)



INFORMATION IN THIS DOCUMENT IS PROVIDED IN CONNECTION WITH INTEL® PRODUCTS. NO LICENSE, EXPRESS OR IMPLIED, BY ESTOPPEL OR OTHERWISE, TO ANY INTELLECTUAL PROPERTY RIGHTS IS GRANTED BY THIS DOCUMENT. EXCEPT AS PROVIDED IN INTEL'S TERMS AND CONDITIONS OF SALE FOR SUCH PRODUCTS, INTEL ASSUMES NO LIABILITY WHATSOEVER, AND INTEL DISCLAIMS ANY EXPRESS OR IMPLIED WARRANTY, RELATING TO SALE AND/OR USE OF INTEL PRODUCTS INCLUDING LIABILITY OR WARRANTIES RELATING TO FITNESS FOR A PARTICULAR PURPOSE, MERCHANTABILITY, OR INFRINGEMENT OF ANY PATENT, COPYRIGHT OR OTHER INTELLECTUAL PROPERTY RIGHT. Intel products are not intended for use in medical, life saving, or life sustaining applications.

Intel may make changes to specifications and product descriptions at any time, without notice.

Designers must not rely on the absence or characteristics of any features or instructions marked "reserved" or "undefined." Intel reserves these for future definition and shall have no responsibility whatsoever for conflicts or incompatibilities arising from future changes to them.

The Mobile Intel® Pentium® 4 Processor with 533 MHz system bus may contain design defects or errors known as errata which may cause the product to deviate from published specifications. Current characterized errata are available on request.

†Hyper-Threading Technology requires a computer system with a Mobile Intel Pentium 4 Processor, a chipset and BIOS that utilize this technology, and an operating system that includes optimizations for this technology. Performance will vary depending on the specific hardware and software you use. See <http://www.intel.com/info/hyperthreading> for information.

Contact your local Intel sales office or your distributor to obtain the latest specifications and before placing your product order.

Intel, Pentium, Celeron, Intel Xeon, Intel SpeedStep, Intel NetBurst and the Intel logo are trademarks or registered trademarks of Intel Corporation or its subsidiaries in the United States and other countries.

*Other names and brands may be claimed as the property of others.

Copyright © 2003 – 2006, Intel Corporation. All rights reserved.



Contents

- Revision History 4
- Preface 5
- Summary Tables of Changes 7
- Identification Information 11
- Errata 13
- Specification Changes 32
- Specification Clarifications 33
- Documentation Changes 34

Revision History

Version	Description	Date of Revision
-001	Initial Release	June 2003
-002	Added Erratum Z29.	July 2003
-003	Updated Errata Z25. Added Errata Z30.	August 2003
-004	Added Errata Z31, Z32, Z33, and Z34.	September 2003
-005	Updated Mobile Intel Pentium 4 processor Identification Information table (added 3.20 GHz and S-spec for HT parts)	September 2003
-006	Added Errata Z35.	October 2003
-007	Updated Errata Z35. Added Errata Z36.	November 2003
-008	Added Specification Changes Z1. Updated Figure 1 (Processor markings).	February 2004
-009	Added Errata Z37	March 2004
-010	Updated Errata Z36	April 2004
-011	Updated Errata Z13. Added Errata Z38	May 2004
-012	Added Errata Z39-41.	June 2004
-013	Updated Errata Z41	June 2004
-014	Added Errata Z40 Updated title of Errata Z34 Updated Errata Z25 Deleted Errata Z9 & Z19 – it does not apply Re-numbers the errata	August 2004
-015	Added Errata Z41	September 2004
-016	Added Errata Z42-43	October 2004
-017	Added Errata Z44	November 2004
-018	Added Errata Z45	December 2004
-019	Updated Summary Tables of Changes Updated Errata Z23 Added Specification Clarification Z1	May 2005
-020	Updated Related Documents Table	September 2005
-021	Added Errata Z46	October 2005
-022	Added Errata Z47 Removed Specification Clarification Z1; refer to Section 18.8 of the <i>IA-32 Intel® Architecture Software Developer's Manual, Volume 3B</i> for detailed Time Stamp Counter information.	January 2006

§



Preface

This document is an update to the specifications contained in the documents listed in the following Affected Documents/Related Documents table. It is a compilation of device and document errata, specification clarifications, and specification changes and is intended for hardware system manufacturers and for software developers of applications, operating system, and tools.

Information types defined in the Nomenclature section of this document are consolidated into this update document and are no longer published in other documents. This document may also contain information that has not been previously published.

Affected Documents

Document Title	Document Number/Location
<i>Mobile Intel® Pentium® 4 Processor with 533 MHz System Bus Datasheet</i>	253028

Related Documents

Document Title	Document Number/Location
<i>Intel® Architecture Software Developer's Manual, Volume 1: Basic Architecture</i>	253665
<i>Intel® Architecture Software Developer's Manual, Volume 2A: Instruction Set Reference, A-M</i>	253666
<i>Intel® Architecture Software Developer's Manual, Volume 2B: Instruction Set Reference, N-Z</i>	253667
<i>Intel® Architecture Software Developer's Manual, Volume 3A: System Programming Guide</i>	253668
<i>Intel® Architecture Software Developer's Manual, Volume 3B: System Programming Guid</i>	253669
<i>IA-32 Intel® Architecture Optimization Reference Manual</i>	248966

Nomenclature

S-Spec Number is a five-digit code used to identify products. Products are differentiated by their unique characteristics, e.g., core speed, L2 cache size, package type, etc. as described in the processor identification information table. Care should be taken to read all notes associated with each S-Spec number

Errata are design defects or errors. Errata may cause the mobile Intel® Pentium® processor's behavior to deviate from published specifications. Hardware and software designed to be used with a-y given stepping must assume that all errata documented for that stepping are present on all devices.

Specification Changes are modifications to the current published specifications. These changes will be incorporated in the next release of the specifications.

Specification Clarifications describe a specification in greater detail or further highlight a specification's impact to a complex design situation. These clarifications will be incorporated in the next release of the specifications.

Documentation Changes include typos, errors, or omissions from the current published specifications. These changes will be incorporated in the next release of the specifications.



Summary Tables of Changes

The following table indicates the Errata, Documentation Changes, Specification Clarifications, or Specification Changes that apply to Intel Pentium 4 processors. Intel intends to fix some of the errata in a future stepping of the component, and to account for the other outstanding issues through documentation or specification changes as noted. This table uses the following notations:

Codes Used in Summary Tables

Stepping

X: Erratum, Specification Change or Clarification that applies to this stepping.

(No mark) or (Blank Box): This erratum is fixed in listed stepping or specification change does not apply to listed stepping.

Status

Doc: Document change or update that will be implemented.

PlanFix: This erratum may be fixed in a future stepping of the product.

Fixed: This erratum has been previously fixed.

NoFix: There are no plans to fix this erratum.

PKG: This column refers to errata on the the Intel® Pentium® 4 processor substrate.

AP: APIC related erratum.

Shaded: This item is either new or modified from the previous version of the document.

Note: Each Specification Update item is prefixed with a capital letter to distinguish the product. The key below details the letters that are used in Intel's microprocessor Specification Updates:

A = Intel® Pentium® II processor

B = Mobile Intel® Pentium® II processor

C = Intel® Celeron® processor

D = Intel® Pentium® II Xeon® processor

E = Intel® Pentium® III processor

G = Intel® Pentium® III Xeon® processor

H = Mobile Intel® Celeron® processor at 466 MHz, 433 MHz, 400 MHz, 366 MHz, 333 MHz, 300 MHz, and 266 MHz

K = Mobile Intel® Pentium® III Processor – M



M = Mobile Intel® Celeron® processor

N = Intel® Pentium® 4 processor

O = Intel® Xeon® processor MP

P = Intel® Xeon® processor

Q = Mobile Intel® Pentium® 4 processor supporting Hyper-Threading Technology on 90-nm technology process

R = Intel® Pentium® 4 processor on 90 nm process

S = Intel® Xeon® Processor with 800 MHz System Bus

T = Mobile Intel® Pentium® 4 processor – M

V = Intel® Celeron® processor in the 478-Pin Package

W = Intel® Celeron® M processor

X = Intel® Pentium® M processor on 90 nm process with 2-MB L2 cache

Y = Intel® Pentium® M processor

Z = Mobile Intel® Pentium® 4 processor with 533 MHz System Bus

NO.	Stepping	Plans	ERRATA
	D1		
Z1	X	NoFix	I/O restart in SMM may fail after simultaneous machine check exception (MCE)
Z2	X	NoFix	MCA registers may contain invalid information if RESET# occurs and PWRGOOD is not held asserted
Z3	X	NoFix	Transaction is not retried after BINIT#
Z4	X	NoFix	Invalid opcode 0FFFh requires a ModRM byte
Z5	X	NoFix	FSW may not be completely restored after page fault on FRSTOR or FLDENV instructions
Z6	X	NoFix	The processor flags #PF instead of #AC on an unlocked CMPXCHG8B instruction
Z7	X	NoFix	When in no-fill mode the memory type of large pages are incorrectly forced to uncacheable
Z8	X	NoFix	Processor may hang due to speculative page walks to non-existent system memory
Z9		NoFix	MCA error code field in IA32_MC0_STATUS register may become out of sync with the rest of the register
Z10	X	NoFix	The IA32_MC1_STATUS register may contain incorrect information for correctable errors
Z11	X	NoFix	Debug mechanisms may not function as expected
Z12	X	NoFix	Machine check architecture error reporting and recovery may not work as expected
Z13	X	NoFix	Cascading of performance counters does not work correctly when forced overflow is enabled
Z14	X	NoFix	EMON event counting of x87 loads may not work as expected
Z15		PlanFix	Buffer on resistance may exceed specification
Z16	X	NoFix	Processor issues inconsistent transaction size attributes for locked operation
Z17	X	NoFix	When the processor is in the System Management Mode (SMM), debug registers may be fully writeable



NO.	Stepping	Plans	ERRATA
	D1		
Z18	X	NoFix	IA32_MC0_ADDR and IA32_MC0_MISC registers will contain invalid or stale data following a Data, Address, or Response Parity Error
Z19	X	NoFix	Processor may hang under certain frequencies and 12.5% STPCLK# duty cycle
Z20	X	NoFix	System may hang if a fatal cache error causes Bus Write Line (BWL) transaction to occur to the same cache line address as an outstanding Bus Read Line (BRL) or Bus Read-Invalidate Line (BRIL)
Z21	X	NoFix	Simultaneous assertion of A20M# and INIT# may result in incorrect data fetch
Z22	X	NoFix	A Write to APIC Registers Sometimes May Appear to Have Not Occurred
Z23	X	PlanFix	STPCLK# Signal Assertion under Certain Conditions May Cause a System Hang
Z24	X	NoFix	Parity Error in the L1 Cache may Cause the Processor to Hang
Z25	X	NoFix	Disabling a Local APIC Disables Both Logical Processor APICs on a Hyper-Threading Technology Enabled Processor
Z26	X	NoFix	STPCLK Throttling and Executing Code from Very Slow Memory Could Lead to a System Hang
Z27	X	NoFix	The State of the Resume Flag (RF Flag) in a Task-State Segment (TSS) May be Incorrect
Z28	X	NoFix	Changes to CR3 Register do not Fence Pending Instruction Page Walks
Z29	X	PlanFix	Simultaneous Page Faults at Similar Page Offsets on Both Logical Processors of a Hyper-Threading Technology Enabled Processor May Cause Application Failure
Z30	X	NoFix	System Bus Interrupt Messages without Data that Receive a HardFailure Response May Hang the Processor
Z31	X	NoFix	Memory Type of the Load Lock Different from its Corresponding Store Unlock
Z32	X	NoFix	Shutdown and IERR# May Result Due to a Machine Check Exception on a Hyper-Threading Technology Enabled Processor
Z33	X	NoFix	A 16-bit Address Wrap Resulting from a Near Branch (Jump or Call) May Cause an Incorrect Address to Be Reported to the #GP Exception Handler
Z34	X	NoFix	Locks and SMC Detection May Cause the Processor to Temporarily Hang
Z35	X	NoFix	Incorrect Debug Exception (#DB) May Occur When a Data Breakpoint is set on an FP Instruction
Z36	X	NoFix	xAPIC May Not Report Some Illegal Vector Errors
Z37	X	PlanFix	Incorrect Duty Cycle is Chosen when On-Demand Clock Modulation is Enabled in a Processor Supporting Hyper-Threading Technology
Z38	X	NoFix	Memory Aliasing of Pages as Uncacheable Memory Type and Write Back (WB) May Hang the System
Z39	X	PlanFix	A Timing Marginality in the Instruction Decoder Unit May Cause an Unpredictable Application Behavior and/or System Hang
Z40	X	NoFix	Missing Stop Grant Acknowledge Special Bus Cycle May Cause a System Hang
Z41	X	PlanFix	A Timing Marginality in the Arithmetic Logic Unit (ALU) May Cause Indeterminate Behavior
Z42	X	NoFix	With TF (Trap Flag) Asserted, FP Instruction That Triggers an Unmasked FP Exception May Take Single Step Trap Before Retirement of Instruction

NO.	Stepping	Plans	ERRATA
	D1		
Z43	X	NoFix	BTS(Branch Trace Store) and PEBS(Precise Event Based Sampling) May Update Memory outside the BTS/PEBS Buffer
Z44	X	NoFix	Memory Ordering Failure May Occur with Snoop Filtering Third-Party Agents after Issuing and Completing a BWIL (Bus Write Invalidate Line) or BLW (Bus Locked Write) Transaction
Z45	X	NoFix	Control Register 2 (CR2) Can be Updated during a REP MOVSB/STOSB Instruction with Fast Strings Enabled
Z46	X	NoFix	Writing the Local Vector Table (LVT) when an Interrupt Is Pending May Cause an Unexpected Interrupt
Z47	X	No Fix	A Write to an APIC Register Sometimes May Appear to Have Not Occurred

Number	SPECIFICATION CHANGE
Z1	Minimum and Maximum A1 Dimension for Alternate Equivalent Package Have Been Updated

Number	SPECIFICATION CLARIFICATIONS
Z1	Specification Clarification with Respect to Time-stamp Counter - Removed

Number	DOCUMENTATION CHANGES
	There are no Documentation Changes in this Specification Update revision.

§



Identification Information

The Mobile Intel® Pentium® 4 processor can be identified by the following values:

Family ¹	Model ²	Brand ID ³
1111	0010	00001110
1111	0010	00001111

NOTE:

1. The Family corresponds to bits [11:8] of the EDX register after RESET, bits [11:8] of the EAX register after the CPUID instruction is executed with a 1 in the EAX register, and the generation field of the Device ID register accessible through Boundary Scan.
2. The Model corresponds to bits [7:4] of the EDX register after RESET, bits [7:4] of the EAX register after the CPUID instruction is executed with a 1 in the EAX register, and the model field of the Device ID register accessible through Boundary Scan.
3. The Brand ID corresponds to bits [7:0] of the EBX register after the CPUID instruction is executed with a 1 in the EAX register.

Table 1. Mobile Intel® Pentium® 4 Processor Identification Information

S-Spec	Core Stepping	L2 Cache Size (bytes)	Processor Signature	Core Frequency Perf Mode/ Batt Mode	Bus Freq	Voltage Perf Mode (Max)/Batt Mode	Package and Revision	Notes
SL723	D1	512K	0F29	2.40GHz/1.60GHz	533 MHz	1.525V/1.200V	31.0 mm FC rev 1.0	1
SL724	D1	512K	0F29	2.66GHz/1.60GHz	533 MHz	1.525V/1.200V	31.0 mm FC rev 1.0	1
SL725	D1	512K	0F29	2.80GHz/1.60GHz	533 MHz	1.525V/1.200V	31.0 mm FC rev 1.0	1
SL726	D1	512K	0F29	3.06GHz/1.60GHz	533 MHz	1.550V/1.200V	31.0 mm FC rev 1.0	1
SL77M	D1	512K	0F29	2.66GHz/1.60GHz	533 MHz	1.550V/1.200V	31.0 mm FC rev 1.0	1,2
SL77N	D1	512K	0F29	2.80GHz/1.60GHz	533 MHz	1.525V/1.200V	31.0 mm FC rev 1.0	1,2
SL77P	D1	512K	0F29	3.06GHz/1.60GHz	533 MHz	1.550V/1.200V	31.0 mm FC rev 1.0	1,2
SL77R	D1	512K	0F29	3.20GHz/1.60GHz	533 MHz	1.550V/1.200V	31.0 mm FC rev 1.0	1,2

NOTE:

1. These parts are multiple VIDs
2. Supports Hyper-Threading Technology

Component Marking Information

Figure 1. Mobile Intel® Pentium® 4 Processor with 533 MHz System Bus Markings

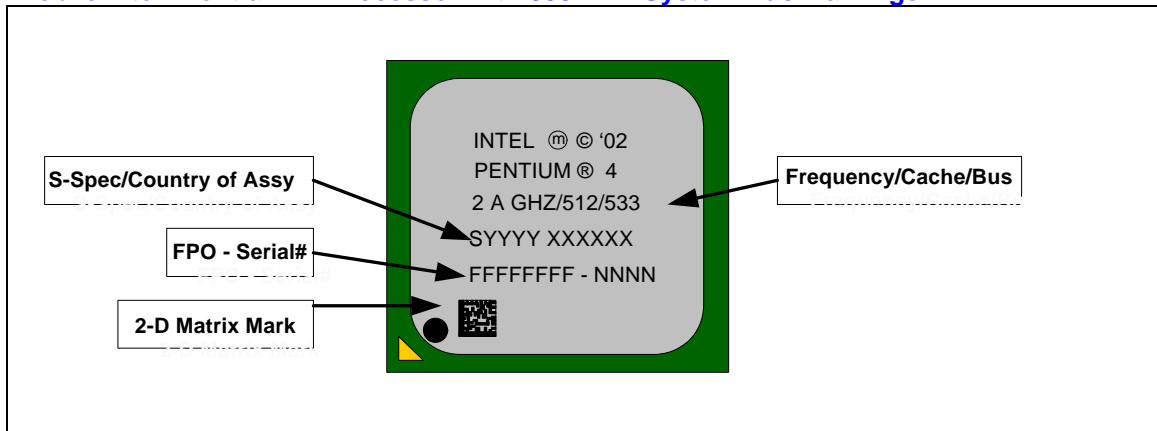

Errata

Z1. I/O Restart in SMM May Fail after Simultaneous Machine Check Exception (MCE)

Problem: If an I/O instruction (IN, INS, REP INS, OUT, OUTS, or REP OUTS) is being executed, and if the data for this instruction becomes corrupted, the processor will signal a Machine Check Exception (MCE). If the instruction is directed at a device that is powered down, the processor may also receive an assertion of SMI#. Since MCEs have higher priority, the processor will call the MCE handler, and the SMI# assertion will remain pending. However, upon attempting to execute the first instruction of the MCE handler, the SMI# will be recognized and the processor will attempt to execute the SMM handler. If the SMM handler is completed successfully, it will attempt to restart the I/O instruction, but will not have the correct machine state, due to the call to the MCE handler.

Implication: A simultaneous MCE and SMI# assertion may occur for one of the I/O instructions above. The SMM handler may attempt to restart such an I/O instruction, but will have an incorrect state due to the MCE handler call, leading to failure of the restart and shutdown of the processor.

Workaround: If a system implementation must support both SMM and board I/O restart, the first thing the SMM handler code should do is check for a pending MCE. If there is an MCE pending, the SMM handler should immediately exit via an RSM instruction and allow the MCE handler to execute. If there is no MCE pending, the SMM handler may proceed with its normal operation.

Status: For the steppings affected, see the *Summary Tables of Changes*.

Z2. MCA Registers May Contain Invalid Information If RESET# Occurs and PWRGOOD Is Not Held Asserted

Problem: This erratum can occur as a result either of the following events:

Example: PWRGOOD is de-asserted during a RESET# assertion causing internal glitches that may result in the possibility that the MCA registers latch invalid information.

Example: Or during a reset sequence if the processor's power remains valid regardless of the state of PWRGOOD, and RESET# is re-asserted before the processor has cleared the MCA registers, the processor will begin the reset process again but may not clear these registers.

Implication: When this erratum occurs, the information in the MCA registers may not be reliable.

Workaround: Ensure that PWRGOOD remains asserted throughout any RESET# assertion and that RESET# is not re-asserted while PWRGOOD is de-asserted.

Status: For the steppings affected, see the *Summary Tables of Changes*.

Z3. Transaction Is Not Retrieved after BINIT#

Problem: If the first transaction of a locked sequence receives a HITM# and DEFER# during the snoop phase it should be retried and the locked sequence restarted. However, if BINIT# is also asserted during this transaction, it will not be retried.

Implication: When this erratum occurs, locked transactions will unexpectedly not be retried.

Workaround: None identified.

Status: For the steppings affected, see the *Summary Tables of Changes*.

Z4. Invalid Opcode 0FFFh Requires a ModRM Byte

Problem: Some invalid opcodes require a ModRM byte (or other following bytes), while others do not. The invalid opcode 0FFFh did not require a ModRM byte in previous generation Intel architecture processors, but does in the Pentium 4 processor.

Implication: The use of an invalid opcode 0FFFh without the ModRM byte may result in a page or limit fault on the Pentium 4 processor.

Workaround: Use a ModRM byte with invalid 0FFFh opcode.

Status: For the steppings affected, see the *Summary Tables of Changes*.

Z5. FSW May Not Be Completely Restored after Page Fault on FRSTOR or FLDENV Instructions

Problem: If the FPU operating environment or FPU state (operating environment and register stack) being loaded by an FLDENV or FRSTOR instruction wraps around a 64-KB or 4-GB boundary and a page fault (#PF) or segment limit fault (#GP or #SS) occurs on the instruction near the wrap boundary, the upper byte of the FPU status word (FSW) might not be restored. If the fault handler does not restart program execution at the faulting instruction, stale data may exist in the FSW.

Implication: When this erratum occurs, stale data will exist in the FSW.

Workaround: Ensure that the FPU operating environment and FPU state do not cross 64-KB or 4-GB boundaries. Alternately, ensure that the page fault handler restarts program execution at the faulting instruction after correcting the paging problem.

Status: For the steppings affected, see the *Summary Tables of Changes*.



Z6. The Processor Flags #PF Instead of #AC on an Unlocked CMPXCHG8B Instruction

Problem: If a data page fault (#PF) and alignment check fault (#AC) both occur for an unlocked CMPXCHG8B instruction, then #PF will be flagged.

Implication: Software that depends #AC before #PF will be affected since #PF is flagged in this case.

Workaround: Remove the software's dependency on the fact that #AC has precedence over #PF. Alternately, reload the page in the page fault handler and then restart the faulting instruction

Status: For the steppings affected, see the *Summary Tables of Changes*.

Z7. When in No-Fill Mode the Memory Type of Large Pages Are Incorrectly Forced to Uncacheable

Problem: When the processor is operating in No-Fill Mode (CR0.CD=1), the paging hardware incorrectly forces the memory type of large (PSE-4M and PAE-2M) pages to uncacheable (UC) memory type regardless of the MTRR settings. By forcing the memory type of these pages to UC, load operations, which should hit valid data in the L1 cache, are forced to load the data from system memory. Some applications will lose the performance advantage associated with the caching permitted by other memory types.

Implication: This erratum may result in some performance degradation when using no-fill mode with large pages.

Workaround: None identified.

Status: For the steppings affected, see the *Summary Tables of Changes*.

Z8. Processor May Hang Due to Speculative Page Walks to Non-Existent System Memory

Problem: A load operation that misses the Data Translation Lookaside Buffer (DTLB) will result in a page-walk. If the page-walk loads the Page Directory Entry (PDE) from cacheable memory and that PDE load returns data that points to a valid Page Table Entry (PTE) in uncacheable memory the processor will access the address referenced by the PTE. If the address referenced does not exist the processor will hang with no response from system memory.

Implication: Processor may hang due to speculative page walks to non-existent system memory.

Workaround: Page directories and page tables in UC memory space which are marked valid must point to physical addresses that will return a data response to the processor.

Status: For the steppings affected, see the *Summary Tables of Changes*.

Z9. MCA Error Code Field in IA32_MC0_STATUS Register May become out of Sync with the Rest of the Register

Problem: The MCA Error Code field of the IA32_MC0_STATUS register gets written by a different mechanism than the rest of the register. For uncorrectable errors, the other fields in the IA32_MC0_STATUS register are only updated by the first error. Any subsequent errors cause the Overflow Error bit to be asserted until this register is cleared. Because of this erratum, any further errors that are detected will update the MCA Error Code field without updating the rest of the register, thereby leaving the IA32_MC0_STATUS register with stale information.

Implication: When this erratum occurs, the IA32_MC0_STATUS register contains stale information.

Workaround: None identified.

Status: For the steppings affected, see the *Summary Tables of Changes*.

Z10. The IA32_MC1_STATUS Register May Contain Incorrect Information for Correctable Errors

Problem: When a speculative load operation hits the L2 cache and receives a correctable error, the IA32_MC1_STATUS register may be updated with incorrect information. The IA32_MC1_STATUS register should not be updated for speculative loads.

Implication: When this erratum occurs, the IA32_MC1_STATUS register will contain incorrect information for correctable errors.

Workaround: None identified.

Status: For the steppings affected, see the *Summary Tables of Changes*.

Z11. Debug Mechanisms May Not Function As Expected

Problem: Certain debug mechanisms may not function as expected on the processor. The cases are as follows:

- When the following conditions occur: 1) An FLD instruction signals a stack overflow or underflow, 2) the FLD instruction splits a page-boundary or a 64 byte cache line boundary, 3) the instruction matches a Debug Register on the high page or cache line respectively, and 4) the FLD has a stack fault and a memory fault on a split access, the processor will only signal the stack fault and the debug exception will not be taken.
- When a data breakpoint is set on the ninth and/or tenth byte(s) of a floating point store using the Extended Real data type, and an unmasked floating point exception occurs on the store, the breakpoint will not be captured.
- When any instruction has multiple debug register matches, and any one of those debug registers is enabled in DR7, all of the matches should be reported in DR6 when the processor goes to the debug handler. This is not true during a REP instruction. As an example, during execution of a REP MOVSW instruction the first iteration a load matches DR0 and DR2 and sets DR6 as FFFF0FF5h. On a subsequent iteration of the instruction, a load matches only DR0. The DR6 register is expected to still contain FFFF0FF5h, but the processor will update DR6 to FFFF0FF1h.
- A data breakpoint that is set on a load to uncacheable memory may be ignored due to an internal segment register access conflict. In this case the system will continue to execute instructions, bypassing the intended breakpoint. Avoiding having instructions that access segment descriptor



registers, e.g., LGDT, LIDT close to the UC load, and avoiding serialized instructions before the UC load will reduce the occurrence of this erratum.

Implication: Certain debug mechanisms do not function as expected on the processor.

Workaround: None identified.

Status: For the steppings affected, see the *Summary Tables of Changes*.

Z12. Machine Check Architecture Error Reporting and Recovery May Not Work As Expected

Problem: When the processor detects errors it should attempt to report and/or recover from the error. In the situations described below, the processor does not report and/or recover from the error(s) as intended. -

- When a transaction is deferred during the snoop phase and subsequently receives a Hard Failure response, the transaction should be removed from the bus queue so that the processor may proceed. Instead, the transaction is not properly removed from the bus queue, the bus queue is blocked, and the processor will hang.
- When a hardware prefetch results in an uncorrectable tag error in the L2 cache, MC0_STATUS.UNCOR and MC0_STATUS.PCC are set but no Machine Check Exception (MCE) is signaled. No data loss or corruption occurs because the data being prefetched has not been used. If the data location with the uncorrectable tag error is subsequently accessed, an MCE will occur. However, upon this MCE, or any other subsequent MCE, the information for that error will not be logged because MC0_STATUS.UNCOR has already been set and the MCA status registers will not contain information about the error which caused the MCE assertion but instead will contain information about the prefetch error event.
- When the reporting of errors is disabled for Machine Check Architecture (MCA) Bank 2 by setting all MC2_CTL register bits to 0, uncorrectable errors should be logged in the IA32_MC2_STATUS register but no machine-check exception should be generated. Uncorrectable loads on bank 2, which would normally be logged in the IA32_MC2_STATUS register, are not logged.
- When one half of a 64 byte instruction fetch from the L2 cache has an uncorrectable error and the other 32 byte half of the same fetch from the L2 cache has a correctable error, the processor will attempt to correct the correctable error but cannot proceed due to the uncorrectable error. When this occurs the processor will hang.
- When an L1 cache parity error occurs, the cache controller logic should write the physical address of the data memory location that produced that error into the IA32_MC1_ADDR REGISTER (MC1_ADDR). In some instances of a parity error on a load operation that hits the L1 cache, the cache controller logic may write the physical address from a subsequent load or store operation into the IA32_MC1_ADDR register.
- When an error exists in the tag field of a cache line such that a request for ownership (RFO) issued by the processor hits multiple tag fields in the L2 cache (the correct tag and the tag with the error) and the accessed data also has a correctable error, the processor will correctly log the multiple tag match error but will hang when attempting to execute the machine check exception handler.
- If a memory access receives a machine check error on both 64 byte halves of a 128-byte L2 cache sector, the IA32_MC0_STATUS register records this event as multiple errors, i.e., the valid error bit and the overflow error bit are both set indicating that a machine check error occurred while the results of a previous error were in the error-reporting bank. The IA32_MC1_STATUS register should also record this event as multiple errors but instead records this event as only one correctable error.
- The overflow bit should be set to indicate when more than one error has occurred. The overflow bit being set indicates that more than one error has occurred. Because of this erratum, if any further errors occur, the MCA overflow bit will not be updated, thereby incorrectly indicating only one error has been received.

- If an I/O instruction (IN, INS, REP INS, OUT, OUTS, or REP OUTS) is being executed, and if the data for this instruction becomes corrupted, the processor will signal a Machine Check Exception (MCE). If the instruction is directed at a device that is powered down, the processor may also receive an assertion of SMI#. Since MCEs have higher priority, the processor will call the MCE handler, and the SMI# assertion will remain pending. However, while attempting to execute the first instruction of the MCE handler, the SMI# will be recognized and the processor will attempt to execute the SMM handler. If the SMM handler is successfully completed, it will attempt to restart the I/O instruction, but will not have the correct machine state due to the call to the MCE handler. This can lead to failure of the restart and shutdown of the processor.
- If PWRGOOD is de-asserted during a RESET# assertion causing internal glitches, the MCA registers may latch invalid information.
- If RESET# is asserted, then de-asserted, and reasserted, before the processor has cleared the MCA registers, then the information in the MCA registers may not be reliable, regardless of the state or state transitions of PWRGOOD.
- If MCERR# is asserted by one processor and observed by another processor, the observing processor does not log the assertion of MCERR#. The Machine Check Exception (MCE) handler called upon assertion of MCERR# will not have any way to determine the cause of the MCE.
- The Overflow Error bit (bit 62) in the IA32_MC0_STATUS register indicates, when set, that a machine check error occurred while the results of a previous error were still in the error reporting bank (i.e. The Valid bit was set when the new error occurred). If an uncorrectable error is logged in the error-reporting bank and another error occurs, the overflow bit will not be set.
- The MCA Error Code field of the IA32_MC0_STATUS register gets written by a different mechanism than the rest of the register. For uncorrectable errors, the other fields in the IA32_MC0_STATUS register are only updated by the first error. Any further errors that are detected will update the MCA Error Code field without updating the rest of the register, thereby leaving the IA32_MC0_STATUS register with stale information.
- When a speculative load operation hits the L2 cache and receives a correctable error, the IA32_MC1_Status Register may be updated with incorrect information. The IA32_MC1_Status Register should not be updated for speculative loads.
- The processor should only log the address for L1 parity errors in the IA32_MC1_Status register if a valid address is available. If a valid address is not available, the Address Valid bit in the IA32_MC1_Status register should not be set. In instances where an L1 parity error occurs and the address is not available because the linear to physical address translation is not complete or an internal resource conflict has occurred, the Address Valid bit is incorrectly set.
- The processor may hang when an instruction code fetch receives a hard failure response from the system bus. This occurs because the bus control logic does not return data to the core, leaving the processor empty. IA32_MC0_STATUS MSR does indicate that a hard fail response occurred.
- The processor may hang when the following events occur and the machine check exception is enabled, CR4.MCE=1. A processor that has its STPCLK# pin asserted will internally enter the Stop Grant State and finally issue a Stop Grant Acknowledge special cycle to the bus. If an uncorrectable error is generated during the Stop Grant process it is possible for the Stop Grant special cycle to be issued to the bus before the processor vectors to the machine check handler. Once the chipset receives its last Stop Grant special cycle it is allowed to ignore any bus activity from the processors. As a result, processor accesses to the machine check handler may not be acknowledged, resulting in a processor hang.

Implication: The processor is unable to correctly report and/or recover from certain errors

Workaround: None identified.

Status: For the steppings affected, see the *Summary Table of Changes*



Z13. Cascading of Performance Counters Does Not Work Correctly When Forced Overflow Is Enabled

Problem: The performance counters are organized into pairs. When the CASCADE bit of the Counter Configuration Control Register (CCCR) is set, a counter that overflows will continue to count in the other counter of the pair. The FORCE_OVF bit forces the counters to overflow on every non-zero increment. When the FORCE_OVF bit is set, the counter overflow bit will be set but the counter no longer cascades.

Implication: The performance counters do not cascade when the FORCE_OVF bit is set.

Workaround: None identified.

Status: For the steppings affected, see the *Summary Tables of Changes*.

Z14. EMON Event Counting of x87 Loads May Not Work As Expected

Problem: If a performance counter is set to count x87 loads and floating point exceptions are unmasked, the FPU Operand Data Pointer (FDP) may become corrupted.

Implication: When this erratum occurs, the FPU Operand Data Pointer (FDP) may become corrupted.

Workaround: This erratum will not occur with floating point exceptions masked. If floating point exceptions are unmasked, then performance counting of x87 loads should be disabled.

Status: For the steppings affected, see the *Summary Tables of Changes*.

Z15. Buffer on Resistance May Exceed Specification

Problem: The datasheet specifies the resistance range for R_{ON} (Buffer On Resistance) for the AGTL+ and Asynchronous GTL+ buffers as 5 to 11 Ohms. Due to this erratum, R_{ON} may be as high as 13.11 Ohms.

Implication: The R_{ON} value affects the voltage level of the signals when the buffer is driving the signal low. A higher R_{ON} may adversely affect the system's ability to meet specifications such as V_{IL} . As the system design also affects margin to specification, designs may or may not have sufficient margin to function properly with an increased R_{ON} . System designers should evaluate whether a particular system is affected by this erratum. Designs that follow the recommendations in the *Intel® Pentium® 4 Processor and Intel® 850 Chipset Platform Design Guide* are not expected to be affected.

Workaround: No workaround is necessary for systems with margin sufficient to accept a higher R_{ON} .

Status: For the steppings affected, see the *Summary Table of Change*.

Z16. Processor Issues Inconsistent Transaction Size Attributes for Locked Operation

Problem: When the processor is in the Page Address Extension (PAE) mode and detects the need to set the Access and/or Dirty bits in the page directory or page table entries, the processor sends an 8 byte load lock onto the system bus. A subsequent 8 byte store unlock is expected, but instead a 4 byte store unlock occurs. Correct data is provided since only the lower bytes change, however external logic monitoring the data transfer may be expecting an 8-byte store unlock.

Implication: No known commercially available chipsets are affected by this erratum.

Workaround: None identified.

Status: For the steppings affected, see the *Summary Tables of Changes*.

Z17. When the Processor Is in the System Management Mode (SMM), Debug Registers May Be Fully Writeable

Problem: When in System Management Mode (SMM), the processor executes code and stores data in the SMRAM space. When the processor is in this mode and writes are made to DR6 and DR7, the processor should block writes to the reserved bit locations. Due to this erratum, the processor may not block these writes. This may result in invalid data in the reserved bit locations.

Implication: Reserved bit locations within DR6 and DR7 may become invalid.

Workaround: Software may perform a read/modify/write when writing to DR6 and DR7 to ensure that the values in the reserved bits are maintained.

For the steppings affected, see the *Summary Tables of Changes*.

Z18. IA32_MC0_ADDR and IA32_MC0_MISC Registers Will Contain Invalid or Stale Data Following a Data, Address, or Response Parity Error

Problem: If the processor experiences a data, address, or response parity error, the ADDR_V and MISC_V bits of the IA32_MC0_STATUS register are set, but the IA32_MC0_ADDR and IA32_MC0_MISC registers are not loaded with data regarding the error.

Implication: When this erratum occurs, the IA32_MC0_ADDR and IA32_MC0_MISC registers will contain invalid or stale data.

Workaround: Ignore any information in the IA32_MC0_ADDR and IA32_MC0_MISC registers after a data, address or response parity error.

Status: For the steppings affected, see the *Summary Tables of Changes*.



Z19. Processor May Hang under Certain Frequencies and 12.5% STPCLK# Duty Cycle

Problem: If a system de-asserts STPCLK# at a 12.5% duty cycle, the processor is running below 2 GHz, and the processor thermal control circuit (TCC) on-demand clock modulation is active, the processor may hang. This erratum does not occur under the automatic mode of the TCC.

Implication: When this erratum occurs, the processor will hang.

Workaround: If use of the on-demand mode of the processor's TCC is desired in conjunction with STPCLK# modulation, then assure that STPCLK# is not asserted at a 12.5% duty cycle.

Status: For the steppings affected, see the *Summary Tables of Changes*.

Z20. System May Hang if a Fatal Cache Error Causes Bus Write Line (BWL) Transaction to Occur to the Same Cache Line Address as an Outstanding Bus Read Line (BRL) or Bus Read-Invalidate Line (BRIL)

Problem: A processor internal cache fatal data ECC error may cause the processor to issue a BWL transaction to the same cache line address as an outstanding BRL or BRIL. As it is not typical behavior for a single processor to have a BWL and a BRL/BRIL concurrently outstanding to the same address, this may represent an unexpected scenario to system logic within the chipset.

Implication: The processor may not be able to fully execute the machine check handler in response to the fatal cache error if system logic does not ensure forward progress on the system bus under this scenario.

Workaround: System logic should ensure completion of the outstanding transactions. Note that during recovery from a fatal data ECC error, memory image coherency of the BWL with respect to BRL/BRIL transactions is not important. Forward progress is the primary requirement.

Status: For the steppings affected, see the *Summary Tables of Changes*.

Z21. Simultaneous Assertion of A20M# and INIT# May Result in Incorrect Data Fetch

Problem: If A20M# and INIT# are simultaneously asserted by software, followed by a data access to the 0xFFFFFXXX memory region, with A20M# still asserted, incorrect data will be accessed. With A20M# asserted, an access to 0xFFFFFXXX should result in a load from physical address 0xFFEFFFXXX. However, in the case of A20M# and INIT# being asserted together, the data load will actually be from the physical address 0xFFFFFXXX. Code accesses are not affected by this erratum.

Implication: Processor may fetch incorrect data, resulting in BIOS failure.

Workaround: Deasserting and reasserting A20M# prior to the data access will workaround this erratum.

Status: For the steppings affected, see the *Summary Tables of Changes*.

Z22. A Write to APIC Registers Sometimes May Appear to Have Not Occurred

Problem: In respect to the retirement of instructions, stores to the uncacheable memory-based APIC register space are handled in a non-synchronized way. For example if an instruction that masks the interrupt flag, e.g. CLI, is executed soon after an uncacheable write to the Task Priority Register (TPR) that lowers the APIC priority, the interrupt masking operation may take effect before the actual priority has been lowered. This may cause interrupts whose priority is lower than the initial TPR, but higher than the final TPR, to not be serviced until the interrupt flag is finally cleared, i.e. by STI instruction. Interrupts will remain pending and are not lost.

Implication: In this example the processor may allow interrupts to be accepted but may delay their service.

Workaround: This non-synchronization can be avoided by issuing an APIC register read after the APIC register write. This will force the store to the APIC register before any subsequent instructions are executed. No commercial operating system is known to be impacted by this erratum.

Status: For the steppings affected, see the *Summary Tables of Changes*.

Z23. STPCLK# Signal Assertion under Certain Conditions May Cause a System Hang

Problem: The assertion of STPCLK# signal before a logical processor awakens from the "Wait-for-SIPI" state for the first time, may cause a system hang. A processor supporting Hyper-Threading Technology may fail to initialize appropriately, and may not issue a Stop Grant Acknowledge special bus cycle in response to the second STPCLK# assertion.

Implication: When this erratum occurs in a Hyper-Threading Technology enabled system, it may cause a system hang.

Workaround: BIOS should initialize the second thread of the processor supporting Hyper-Threading Technology prior to STPCLK# assertion. Additionally, it is possible for the BIOS to contain a workaround for this erratum.

Status: For the steppings affected, see the *Summary of Tables of Changes*.

Z24. Parity Error in the L1 Cache May Cause the Processor to Hang

Problem: If a locked operation accesses a line in the L1 cache that has a parity error, it is possible that the processor may hang while trying to evict the line.

Implication: If this erratum occurs, it may result in a system hang. Intel has not observed this erratum with any commercially available software.

Workaround: None.

Status: For the steppings affected, see the *Summary Tables of Changes*.



Z25. Disabling a Local APIC Disables Both Logical Processor APICs on a Hyper-Threading Technology Enabled Processor

Problem: Disabling a local APIC on one logical processor of a Hyper-Threading Technology enabled processor by clearing bit 11 of the IA32_APIC_BASE MSR will effectively disable the local APIC on the other logical processor.

Implication: Disabling a local APIC on one logical processor prevents the other logical processor from sending or receiving interrupts. Multiprocessor Specification compliant BIOSs and multiprocessor operating systems typically leave all local APICs enabled preventing any end-user visible impact from this erratum.

Workaround: Do not disable the local APICs in a Hyper-Threading Technology enabled processor.

Status: For the steppings affected, see the *Summary Tables of Changes*.

Z26. STPCLK Throttling and Executing Code From Very Slow Memory Could Lead to a System Hang

Problem: The system may hang when the following conditions are met:

1. Periodic STPCLK mechanism is enabled via the chipset
2. Hyper-Threading Technology is enabled
3. One logical processor is waiting for an event (i.e. hardware interrupt)
4. The other logical processor executes code from very slow memory such that every code fetch is deferred long enough for the STPCLK to be re-asserted

Implication: If this erratum occurs, the processor will go into and out of the sleep state without making forward progress, as the logical processor will not be able to service any pending event. This erratum has not been observed in any commercial platform running commercial software.

Workaround: None

Status: For the steppings affected, see the *Summary Tables of Changes*.

Z27. The State of the Resume Flag (RF Flag) in a Task-State Segment (TSS) May be Incorrect

Problem: After executing a JMP instruction to the next (or other) task through a hardware task switch, it is possible for the state of the RF flag (in the EFLAGS register image) to be incorrect.

Implication: The RF flag is normally used for code breakpoint management during debug of an application. It is not typically used during normal program execution. Code breakpoints or single step debug behavior in the presence of hardware task switches, therefore, may be unpredictable as a result of this erratum. This erratum has not been observed in commercially available software.

Workaround: None.

Status: For the steppings affected, see the *Summary Tables of Changes*.

Z28. Changes to CR3 Register do not Fence Pending Instruction Page Walks

Problem: When software writes to the CR3 register, it is expected that all previous/outstanding code, data accesses and page walks are completed using the previous value in CR3 register. Due to this erratum, it is possible that a pending instruction page walk is still in progress, resulting in an access (to the PDE portion of the page table) that may be directed to an incorrect memory address.

Implication: The results of the access to the PDE will not be consumed by the processor so the return of incorrect data is benign. However, the system may hang if the access to the PDE does not complete with data (e.g. infinite number of retries).

Workaround: It is possible for the BIOS to have a workaround for this erratum.

Status: For the steppings affected, see the *Summary Tables of Changes*.

Z29. Simultaneous Page Faults at Similar Page Offsets on Both Logical Processors of a Hyper-Threading Technology Enabled Processor May Cause Application Failure

Problem: An incorrect value of CR2 may be presented to one of the logical processors of an HT Technology enabled processor if a page access fault is encountered on one logical processor in the same clock cycle that the other logical processor also encounters a page fault. Both accesses must cross the same 4 byte aligned offset for this erratum to occur. Only a small percentage of such simultaneous accesses are vulnerable. The vulnerability of the alignment for any given fault is dependent on the state of other circuitry in the processor. Additionally, a third fault from an access that occurs sequentially after one of these simultaneous faults has to be pending at the time of the simultaneous faults. This erratum is caused by a one-cycle hole in the logic that controls the timing by which a logical processor is allowed to access an internal asynchronous fault address register. The end result is that the value of CR2 presented to one logical processor may be corrupted.

Implication: The operating system is likely to terminate the application that generated an incorrect value of CR2.

Workaround: An operating system or page management software can significantly reduce the already small possibility of encountering this failure by restarting or retrying the faulting instruction and only terminate the application on a subsequent failures of the same instruction. It is possible for BIOS to contain a workaround for this erratum.

Status: For the steppings affected, see the *Summary Tables of Changes*.



Z30. System Bus Interrupt Messages without Data that Receive a HardFailure Response May Hang the Processor

Problem: When a system bus agent (processor or chipset) issues an interrupt transaction without data onto the system bus and the transaction receives a HardFailure response, a potential processor hang can occur. The processor, which generates an inter-processor interrupt (IPI) that receives the HardFailure response, will still log the MCA error event cause as HardFailure, even if the APIC causes a hang. Other processors, which are true targets of the IPI, will also hang on hardfail-without-data, but will not record an MCA HardFailure event as the cause. If a HardFailure response occurs on a system bus interrupt message with data, the APIC will complete the operation so as not to hang the processor.

Implication: The processor may hang.

Workaround: None identified.

Status: For the steppings affected, see the *Summary Tables of Changes*.

Z31. Memory Type of the Load Lock Different from its Corresponding Store Unlock

Problem: A use-once protocol is employed to ensure that the processor in a multi-agent system may access data that is loaded into its cache on a Read-for-Ownership operation at least once before it is snooped out by another agent. This protocol is necessary to avoid a multi-agent livelock scenario in which the processor cannot gain ownership of a line and modify it before that data is snooped out by another agent. In the case of this erratum, split load lock instructions incorrectly trigger the use-once protocol. A load lock operation accesses data that splits across a page boundary with both pages of WB memory type. The use-once protocol activates and the memory type for the split halves get forced to UC. Since use-once does not apply to stores, the store unlock instructions go out as WB memory type. The full sequence on the bus is: locked partial read (UC), partial read (UC), partial write (WB), locked partial write (WB). The use-once protocol should not be applied to load locks.

Implication: When this erratum occurs, the memory type of the load lock will be different than the memory type of the store unlock operation. This behavior (load locks and store unlocks having different memory types) does not introduce any functional failures such as system hangs or memory corruption.

Workaround: None identified.

Status: For the steppings affected, see the *Summary Tables of Changes*.

Z32. Shutdown and IERR# May Result Due to a Machine Check Exception on a Hyper-Threading Technology Enabled Processor

Problem: When a Machine Check Exception (MCE) occurs due to an internal error, both logical processors on a Hyper-Threading Technology enabled processor normally vector to the MCE handler. However, if one of the logical processors is in the “Wait-for-SIPI” state, that logical processor will not have an MCE handler and will shut down and assert IERR#.

Implication: A processor with a logical processor in the “Wait-for-SIPI” state will shut down when an MCE occurs on the other thread.

Workaround: None identified.

Status: For the steppings affected, see the *Summary Tables of Changes*.

Z33. A 16-bit Address Wrap Resulting from a Near Branch (Jump or Call) May Cause an Incorrect Address to Be Reported to the #GP Exception Handler

Problem: If a 16-bit application executes a branch instruction that causes an address wrap to a target address outside of the code segment, the address of the branch instruction should be provided to the general protection exception handler. It is possible that, as a result of this erratum, that the general protection handler may be called with the address of the branch target.

Implication: The 16-bit software environment which is affected by this erratum, will see that the address reported by the exception handler points to the target of the branch, rather than the address of the branch instruction.

Workaround: None identified

Status: For the steppings affected, see the *Summary Tables of Changes*.

Z34. Locks and SMC Detection May Cause the Processor to Temporarily Hang

Problem: The processor may temporarily hang in an HT Technology enabled system if one logical processor executes a synchronization loop that includes one or more locks and is waiting for release by the other logical processor. If the releasing logical processor is executing instructions that are within the detection range of the self modifying code (SMC) logic, then the processor may be locked in the synchronization loop until the arrival of an interrupt or other event.

Implication: If this erratum occurs in an HT Technology enabled system, the application may temporarily stop making forward progress. Intel has not observed this erratum with any commercially available software.

Workaround: None identified.

Status: For the steppings affected, see the *Summary Table of Changes*

Z35. Incorrect Debug Exception (#DB) May Occur When a Data Breakpoint Is Set on an FP Instruction

Problem: The default Microcode Floating Point Event Handler routine executes a series of loads to obtain data about the FP instruction that is causing the FP event. If a data breakpoint is set on the instruction causing the FP event, the load in the microcode routine will trigger the data breakpoint resulting in a Debug Exception.

Implication: An incorrect Debug Exception (#DB) may occur if data breakpoint is placed on an FP instruction. Intel has not observed this erratum with any commercially available software or system.

Workaround: None identified.

Status: For the steppings affected, see the *Summary Table of Changes*



Z36. xAPIC May Not Report Some Illegal Vector Errors

Problem: The local xAPIC has an Error Status Register, which records all errors. The bit 6 (the Receive Illegal Vector bit) of this register, is set when the local xAPIC detects an illegal vector in a received message. When an illegal vector error is received on the same internal clock that the error status register is being written (due to a previous error), bit 6 does not get set and illegal vector errors are not flagged.

Implication: The xAPIC may not report some Illegal Vector errors when they occur at approximately the same time as other xAPIC errors. The other xAPIC errors will continue to be reported.

Workaround: None identified.

Status: For the steppings affected, see the *Summary Tables of Changes*.

Z37. Incorrect Duty Cycle Is Chosen when On-Demand Clock Modulation Is Enabled in a Processor Supporting Hyper-Threading Technology

Problem: When a processor supporting Hyper-Threading Technology enables On-Demand Clock Modulation on both logical processors, the processor is expected to select the lowest duty cycle of the two potentially different values. When one logical processor enters the AUTOHALT state, the duty cycle implemented should be unaffected by the halted logical processor. Due to this erratum, the duty cycle is incorrectly chosen to be the higher duty cycle of both logical processors.

Implication: Due to this erratum, higher duty cycle may be chosen when the On-Demand Clock Modulation is enabled on both logical processors.

Workaround: None identified.

Status: For the steppings affected, see the *Summary Tables of Changes*.

Z38. Memory Aliasing of Pages as Uncacheable Memory Type and Write Back (WB) May Hang the System

Problem: When a page is being accessed as either Uncacheable (UC) or Write Combining (WC) and WB, under certain bus and memory timing conditions, the system may loop in a continual sequence of UC fetch, implicit writeback, and Request For Ownership (RFO) retries.

Implication: This erratum has not been observed in any commercially available operating system or application. The aliasing of memory regions, a condition necessary for this erratum to occur, is documented as being unsupported in the *IA-32 Intel® Architecture Software Developer's Manual*, Volume 3, section 10.12.4, Programming the PAT. However, if this erratum occurs the system may hang.

Workaround: The pages should not be mapped as either UC or WC and WB at the same time.

Status: For the steppings affected, see the *Summary Tables of Changes*.

Z39. A Timing Marginality in the Instruction Decoder Unit May Cause an Unpredictable Application Behavior and/or System Hang

Problem: A timing marginality may exist in the clocking of the instruction decoder unit which leads to a circuit slowdown in the read path from the Instruction Decode PLA circuit. This timing marginality may not be visible for some period of time.

Implication: When this erratum occurs, an incorrect instruction stream may be executed resulting in an unpredictable application behavior and/or system hang.

Workaround: It is possible for the BIOS to contain a workaround for this erratum.

Status: For the steppings affected, see the *Summary Tables of Changes*.

Z40. Missing Stop Grant Acknowledge Special Bus Cycle May Cause a System Hang

Problem: If a Stop Grant Acknowledge special bus cycle is deferred by the processor for a period of time long enough for the chipset to de-assert and then re-assert STPCLK# signal, a processor supporting Hyper-Threading Technology may fail to detect the de-assertion and re-assertion of STPCLK# signal. When this occurs, the processor will not issue a Stop Grant Acknowledge special bus cycle in response to the second STPCLK# assertion.

Implication: When this erratum occurs in an HT Technology enabled system, it may cause a system hang.

Workaround: It is possible for the BIOS to contain a workaround for this erratum.

Status: For the steppings affected, see the *Summary Tables of Changes*.

Z41. A Timing Marginality in the Arithmetic Logic Unit (ALU) May Cause Indeterminate Behavior

Problem: A timing marginality may exist in the clocking of the ALU which leads to a slowdown in the speed of the circuit's operation. This could lead to incorrect behavior of the ALU.

Implication: When this erratum occurs, unpredictable application behavior and/or system hang may occur.

Workaround: It is possible for the BIOS to contain a workaround for this erratum.

Status: For the steppings affected, see the *Summary Tables of Changes*.



Z42. With TF (Trap Flag) Asserted, FP Instruction That Triggers an Unmasked FP Exception May Take Single Step Trap Before Retirement of Instruction

Problem: If an FP instruction generates an unmasked exception with the EFLAGS.TF=1, it is possible for external events to occur, including a transition to a lower power state. When resuming from the lower power state, it may be possible to take the single step trap before the execution of the original FP instruction completes.

Implication: A Single Step trap will be taken when not expected.

Workaround: None identified.

Status: For the steppings affected, see the *Summary Tables of Changes*.

Z43. BTS(Branch Trace Store) and PEBS(Precise Event Based Sampling) May Update Memory outside the BTS/PEBS Buffer

Problem: If the BTS/PEBS buffer is defined such that:

- The difference between BTS/PEBS buffer base and BTS/PEBS absolute maximum is not an integer multiple of the corresponding record sizes
- BTS/PEBS absolute maximum is less than a record size from the end of the virtual address space
- The record that would cross BTS/PEBS absolute maximum will also continue past the end of the virtual address space

Implication: Software that uses BTS/PEBS near the 4G boundary (IA32) or 2^{64} boundary (EMT64T mode), and defines the buffer such that it does not hold an integer multiple of records can update memory outside the BTS/PEBS buffer.

Workaround: Define BTS/PEBS buffer such that BTS/PEBS absolute maximum minus BTS/PEBS buffer base is integer multiple of the corresponding record sizes as recommended in the Programmers Reference Manual Volume 3.

Status: For the steppings affected, see the *Summary Tables of Changes*.

Z44. Memory Ordering Failure May Occur with Snoop Filtering Third- Party Agents after Issuing and Completing a BWIL (Bus Write Invalidate Line) or BLW (Bus Locked Write) Transaction

Problem: Under limited circumstances, the processors may, after issuing and completing a BWIL or BLW transaction, retain data from the addressed cache line in shared state even though the specification requires complete invalidation. This data retention may also occur when a BWIL transaction's self-snooping yields HITM snoop results.

Implication: A system may suffer memory ordering failures if its central agent incorporates coherence sequencing which depends on full self-invalidation of the cache line associated with (1) BWIL and BLW transactions, or (2) all HITM snoop results without regard to the transaction type and snoop results' source.

Workaround: 1. The central agent can issue a bus cycle that causes a cache line to be invalidated (Bus Read Invalidate Line (BRIL) or BWIL transaction) in response to a processor-generated BWIL (or BLW) transaction to insure complete invalidation of the associated cache line. If there are no intervening processor-originated transactions to that cache line, the central agent's invalidating snoop will get a clean snoop result.

Or

2. Snoop filtering central agents can:

- a. Not use processor-originated BWIL or BLW transactions to update their snoop filter information, or
- b. Update the associated cache line state information to shared state on the originating bus (rather than invalid state) in reaction to a BWIL or BLW.

Status: For the steppings affected, see the *Summary Tables of Changes*.

Z45. Control Register 2 (CR2) Can be Updated during a REP MOVSB/STOS Instruction with Fast Strings Enabled

Problem: Under limited circumstances while executing a REP MOVSB/STOS string instruction, with fast strings enabled, it is possible for the value in CR2 to be changed as a result of an interim paging event, normally invisible to the user. Any higher priority architectural event that arrives and is handled while the interim paging event is occurring may see the modified value of CR2.

Implication: The value in CR2 is correct at the time that an architectural page fault is signaled. Intel has not observed this erratum with any commercially available software.

Workaround: None Identified

Status: For the steppings affected, see the *Summary Tables of Changes*.

Z46. Writing the Local Vector Table (LVT) When an Interrupt Is Pending May Cause an Unexpected Interrupt

Problem: If a local interrupt is pending when the LVT entry is written, an interrupt may be taken on the new interrupt vector even if the mask bit is set.

Implication: An interrupt may immediately be generated with the new vector when an LVT entry is written, even if the new LVT entry has the mask bit set. If there is no Interrupt Service Routine (ISR) set up for that vector the system will GP fault. If the ISR does not do an End of Interrupt (EOI) the bit for the vector will be left set in the in-service register and mask all interrupts at the same or lower priority.

Workaround: Any vector programmed into an LVT entry must have an ISR associated with it, even if that vector was programmed as masked. This ISR routine must do an EOI to clear any unexpected interrupts that may occur. The ISR associated with the spurious vector does not generate an EOI, therefore the spurious vector should not be used when writing the LVT.

Status: For the steppings affected, see the *Summary Tables of Changes*.



Z47. A Write to an APIC Register Sometimes May Appear to Have Not Occurred

Problem: With respect to the retirement of instructions, stores to the uncacheable memory-based APIC register space are handled in a non-synchronized way. For example if an instruction that masks the interrupt flag, e.g. CLI, is executed soon after an uncacheable write to the Task Priority Register (TPR) that lowers the APIC priority, the interrupt masking operation may take effect before the actual priority has been lowered. This may cause interrupts whose priority is lower than the initial TPR, but higher than the final TPR, to not be serviced until the interrupt enabled flag is finally set, i.e. by STI instruction. Interrupts will remain pending and are not lost.

Implication: In this example, the processor may allow interrupts to be accepted but may delay their service.

Workaround: This non-synchronization can be avoided by issuing an APIC register read after the APIC register write. This will force the store to the APIC register before any subsequent instructions are executed. No commercial operating system is known to be impacted by this erratum.

Status: For the steppings affected, see the *Summary Tables of Changes*.

§

Specification Changes

There are no Specification Changes in this Specification Update revision.

§



Specification Clarifications

There are no Specification Clarifications in this Specification Update revision.

§

Documentation Changes

There are no Documentation Changes in this Specification Update revision.

§