

DCMI Conformance Test Suite (DCTS for Windows) User Guide

Rev 1.5.0.27

Notice: This document contains information on products in the design phase of development. The information here is subject to change without notice. Do not finalize a design with this information.

INFORMATION IN THIS SPECIFICATION [DOCUMENT] IS PROVIDED IN CONNECTION WITH INTEL[®] PRODUCTS. NO LICENSE, EXPRESS OR IMPLIED, BY ESTOPPEL OR OTHERWISE, TO ANY INTELLECTUAL PROPERTY RIGHTS IS GRANTED BY THIS DOCUMENT. EXCEPT AS PROVIDED IN INTEL'S TERMS AND CONDITIONS OF SALE FOR SUCH PRODUCTS.

INTEL ASSUMES NO LIABILITY WHATSOEVER, AND INTEL DISCLAIMS ANY EXPRESS OR IMPLIED WARRANTY, RELATING TO SALE AND/OR USE OF INTEL PRODUCTS INCLUDING LIABILITY OR WARRANTIES RELATING TO FITNESS FOR A PARTICULAR PURPOSE, MERCHANTABILITY, OR INFRINGEMENT OF ANY PATENT, COPYRIGHT OR OTHER INTELLECTUAL PROPERTY RIGHT. Intel products are not intended for use in medical, life saving, life sustaining applications.

Intel may make changes to specifications and product descriptions at any time, without notice.

Designers must not rely on the absence or characteristics of any features or instructions marked reserved or undefined. Intel reserves these for future definition and shall have no responsibility whatsoever for conflicts or incompatibilities arising from future changes to them.

Contact your local Intel sales office or your distributor to obtain the latest specifications and before placing your product order.

Copies of documents which have an order number and are referenced in this document, or other Intel literature, may be obtained by calling 1-800-548-4725, or by visiting [Intel's Web Site](#).

Intel and the Intel logo are trademarks or registered trademarks of Intel Corporation or its subsidiaries in the United States and other countries.

Copyright © 2011, Intel Corporation. All rights reserved.

* Other brands and names may be claimed as the property of others.

Table of contents

1. GLOSSARY OF TERMS	12
2. INTRODUCTION	13
2.1 SCOPE AND PURPOSE	13
2.2 AUDIENCE	13
2.3 LOCATION OF THIS DOCUMENT	13
2.4 CHANGE HISTORY	13
3. DCMI CONFORMANCE SUITE OVERVIEW	14
3.1 GENERAL DESCRIPTION	14
3.2 SOFTWARE COMPONENTS	14
3.3 USERCONF.CFG	15
4. USAGE PRE-REQUISITES	16
4.1 INSTALLATION	16
4.2 OUT-OF-BAND TESTING	16
4.2.1 <i>Network Connectivity & IPMI Session Configuration</i>	16
4.2.2 <i>DCTS Configuration</i>	17
4.2.3 <i>DHCP/DCMI Discovery</i>	17
4.3 IN-BAND TESTING	18
4.3.1 <i>Driver Installation</i>	18
5. TEST EXECUTION	19
6. TEST COMPLETION	20
7. TROUBLESHOOTING GUIDE	22
APPENDIX A	23
APPENDIX B — SPECIFICATION CROSS REFERENCE	28
APPENDIX C – EXCERPTS FROM RESULTS.LOG	31

1. Glossary of Terms

This document uses the following terms and abbreviations:

Term	Definition
DCMI	Data Center Management Interface
DCTS	DCMI Conformance Test Suite
FW	Firmware
IB	In Band
IOL	IPMI over Lan
IPDC	Internet Portal Data Center
IPMI	Intelligent Platform Management Interface
KCS	Keyboard Controller Style
MC	Management Console
NIC	Network Interface Card
NM	Node Manager
OEM	Original Equipment Manufacturer
OOB	Out of Band
OS	Operating System
RMCP	Remote Management Control Protocol
SDR	Sensor Data Record
SEL	System Event Log
TBD	ToBe Determined
TCP/IP	Transmission Control Protocol/Internet Protocol
TMode	Terminal Mode
UUT	Unit Under Test

2. Introduction

2.1 Scope and Purpose

This document covers operational procedures, configuration and setup needed to run the DCMI conformance test suite (DCTS).

Please note that currently DCTS covers the functionality of the DCMI specification: 1.1 and 1.5

2.2 Audience

This document is intended for use by Validation Engineers, Program/Project Managers and Development Engineers to test DCMI compliance. It is assumed that the reader has a background in Server manageability and DCMI.

2.3 Location of this Document

Updates to the user document can be obtained from the following link:

<http://www.intel.com/technology/product/DCMI/index.htm>

2.4 Change History

Date	Rev	Comments
08/11/2011	1.5.00.026	Initial Release
16/12/2011	1.5.00.027	Hot fix for Sensor Discovery

DCTS 1.1 Change History

Date	Rev	Comments
11/10/10	(1.1.) 2.0	Updated from 1.4 version for DCMI 1.1 DCTS Release: 2.0
24/05/11	(1.1.) 2.3	Fixed: - SHA256 Truncation - Cipher Suite Entries invalid response data size expectation – result the test failed, if there was listed all allowable entries - Fixed messages for optional features: <ul style="list-style-type: none">- SEL Roll over- Optional Platform Attributes- Enhanced System Power Statistics Attribute - Changes in the delays for SEL Entries test cases

3. DCMI Conformance Suite Overview

3.1 General Description

The DCMI Conformance Test Suite (DCTS) provides a baseline set of tests for verifying compliance with the Data Center Management Interface (DCMI) specification (in both version 1.1 and 1.5). DCTS is designed to perform “Black Box” testing, wherein the focus is solely on the outputs generated in response to selected inputs and execution conditions. The primary objectives of the test suite are:

1. Reduce ambiguity in the specifications interface description.
2. Increase customer’s confidence in interoperability between different implementations.
3. Identify which parts of the specification have been implemented.
4. Help implementers and users understand how the DCMI interfaces are expected to be called.

DCTS presents a simple menu driven user interface. Each test scenario verifies a logical unit of functionality and reports a pass, a fail or a skipped. A cross reference of tests to DCMI specification references can be viewed in Appendix B.

Based on the method chosen for communication with the target system, the following two modes of testing are supported.

- **In-Band Testing (IB)**
 - Using KCS or HECI Interface
 - The test tool resides on the Server Platform (UUT)
- **Out-of-Band Testing (OOB)**
 - Using Ethernet LAN based connectivity via IPMI/RMCP+ protocol
 - The test tool resides on the remote PC.

3.2 Software Components

The package is distributed as an extracting package; it contains the files listed below and all files should be extracted to the same directory.

- **DCMIConformance.exe** - WIN32 application, that serves as the
 - Presentation layer for user Input/Output
 - Send, receive and process the commands.
 - Report results
- **TransportInBand.dll** - In-band driver component via KCS and HECI
- **TransportRMCP.dll** - Out-of-band driver component.
- **userconf.cfg** - Text file for configuring the user and network environment.
- **DCTS_Windows_ReleaseNotes.txt** - Text file that has the release information.

3.3 Userconf.cfg

The basic network and session configuration for the test environment is extracted from the file “UserConf.cfg”. Please note this is a text file and it is modeled after the “.ini” file that is commonly used in the Windows environment. A complete list of parameters along with default values are listed in the sample user config file in Appendix A.

4. Usage Pre-Requisites

All the prep-work listed in this section should be completed before starting the actual test run.

4.1 Installation

- Extract the DCMI_Conformance.zip file into a folder of your choice.
 - For OOB application install on your client PC.
 - Client PC should be running Windows Operating System 32bit compatible¹
 - For IB application install on the UUT or Target Server.
 - Requires Windows Operating System 32bit compatible¹
 - Obtain, install, and configure on the client PC/Server any utility that will allow you to view the TCP/IP packets that will need to be observed during the platform DHCP discovery operation.

4.2 Out-of-Band testing

4.2.1 Network Connectivity & IPMI Session Configuration

It is assumed that the user is familiar with the tools and procedures to configure the server manageability stack on the UUT.

- The Manageability Controller should be configured for IP connectivity, this implies IP address and ensuring there is IP based network connectivity between the UUT and the host PC.
- The test is intended to run in a one-to-one configuration. It is not meant to run on a network with significant network traffic.

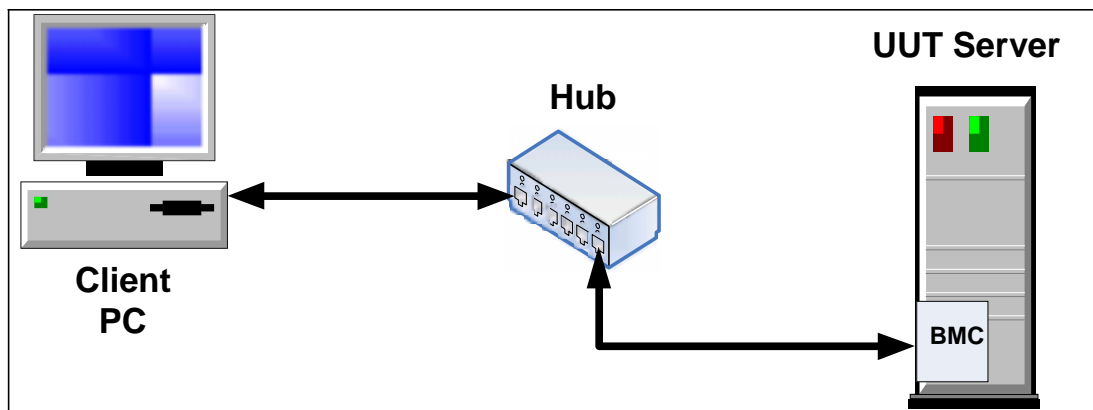

- A set of usernames and passwords with admin privilege should be configured on the server as part of BMC provisioning

¹ suitable: Windows XP, Windows Server 2003, Windows Server 2008, Windows 7

4.2.2 DCTS Configuration

The recommended values for testing are shown below.

```
[DCMI_Conformance]
# screen-output
screen-output=summary

# log-to-file
log-to-file=summary

# log-file-name
log-file-name=results.log

[RMCPP]
# Target IP of UUT (assigned to FW)
targetIP=xxx.xxx.xxx.xxx

# User Name
username=username

#Cipher Suite
CipherSuite=3

[TimeOutValues]
TimeOutPwrOn=15
TimeOutPwrOff=30
TimeOutLedBlink=15
TimeOutSELReserve=1
TimeOutSELGet=1
TimeOutSELClear=1
```

4.2.3 DHCP/DCMI Discovery

1. This test is in support of Test Case 13.1 of the DCMI Conformance Test Suite.
2. This test assumes that the user will be using DHCP for the target server.
3. Start the packet sniffing tool and insure you are reading from the test network port that is connected to your test network.
4. DC cycle the UUT to off.
5. Cycle AC power off for about 10-15 seconds.
6. Cycle AC power on.
7. Immediately after AC power on, use the packet capture tool to capture the initial DHCP discovery packet and verify the DHCP host name.
8. Take note that the host name as this will not be requested in the test execution but it is recommended to verify it.

4.3 In-Band testing

4.3.1 Driver Installation

IPMI Driver:

In the case of in-band testing the management and monitoring tools need to be selected and the ipmi driver installed⁽¹⁾. Please refer to the reference [http://msdn.microsoft.com/en-us/library/aa391402\(VS.85\).aspx](http://msdn.microsoft.com/en-us/library/aa391402(VS.85).aspx). The steps are listed below:

- Select Control Plane
 - Add or Remove Programs
 - Add/Remove Windows Components
 - Select Management and Monitoring Tools
 - Deselect Microsoft .NET Framework* 2.0
- At the command prompt enter <runll32 ipmissetp.dll, AddTheDevice>⁽²⁾

(1) The standard install of Windows may not include the complete list of files needed for enabling the management and monitoring tools. Have your install CD/DVD available to enable the tools. Also, insure you have administrator rights to install the components.

(2) User will not get an indication that this passes or fails.

HECI & DCMI-HI (formerly IDC-HI) Drivers

Please refer to the readme files for the installation instructions.

5. Test Execution

1. Open a command window on the Client PC(3) if executing OOB or on the Unit.
2. Under Test if running IB.
3. Verify if running OOB that the UUT is turned on and booted to the OS.
4. Move to the directory that has the DCMIconformance.exe file resident.

Run DCMIconformance.exe and the menu will open as shown in the screen shot below.

Please notice that currently DCTS is supporting both DCMI specification versions: 1.1 and 1.5, so please select appropriate options.

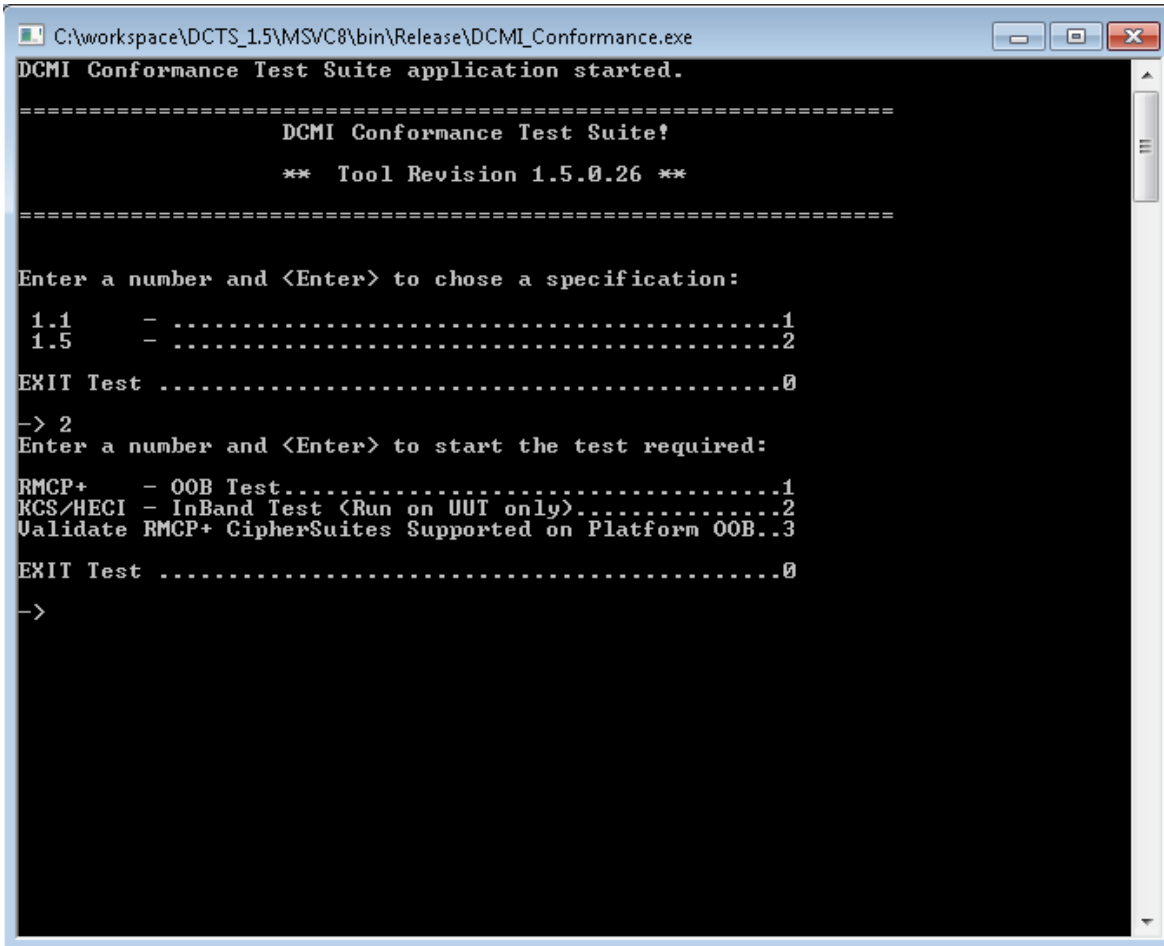

```
C:\workspace\DCTS_1.5\MSVC8\bin\Release\DCMI_Conformance.exe
DCMI Conformance Test Suite application started.
=====
                    DCMI Conformance Test Suite!
                    ** Tool Revision 1.5.0.26 **
=====

Enter a number and <Enter> to chose a specification:
 1.1      - .....1
 1.5      - .....2
EXIT Test .....0
-> 2
Enter a number and <Enter> to start the test required:
RMCP+    - OOB Test.....1
KCS/HECI - InBand Test (Run on UUT only).....2
Validate RMCP+ CipherSuites Supported on Platform OOB..3
EXIT Test .....0
->
```

Figure 1 Sample view

NOTE: At various times the test will delay. You may see the prompt; **“Delay for: X s”**². This is primarily used to allow the Manageability controller to stabilize before and after power cycles and during flash reads and writes which take longer to execute than routine command issues.

Administrator rights not needed to execute the in-band test.

² Depending on verbosity level

6. Test Completion

On completion of the test run, the summary results will appear as shown below.

Please note the results are captured in results.log file in the same directory where the executable is located. The log will contain details of the test execution summary.

There are four possible outcomes to each test case:

- **PASS** all the expectations for those test cases were met.
- **FAIL** at least one of the test failed
- **ABORTED** test could not be completed due to connectivity issues.
- **SKIPPED** skipped because the feature is not supported.

```

C:\windows\System32\cmd.exe
C:\workspace\DCMI_1.5\MSUCS\bin\Release>DCMI_Conformance.exe
DCMI Conformance Test Suite application started.

=====
DCMI Conformance Test Suite!
** Tool Revision 1.5.0.26 **
=====

Enter a number and <Enter> to chose a specification:
1.1 - .....1
1.5 - .....2
EXIT Test .....0
-> 2
Enter a number and <Enter> to start the test required:
RMCP+ - OOB Test.....1
KCS/HECI - InBand Test (Run on UUT only).....2
Validate RMCP+ CipherSuites Supported on Platform OOB.3
EXIT Test .....0
-> 1
Establishing RMCP+ session with CipherSuite: 3
Checking Supported DCMI Capabilities for Platform.
Checking Manageability Access Attributes.
Tests 1, Basic Discovery
Test Case 1.1 : Supported DCMI Platform Capabilities
PASS
Test Case 1.2 : Manageability Access Attributes
PASS
Test Case 1.3 : Session Less Capabilities
PASS
Test Case 1.4 : Minimum Platform Attributes
PASS
Test Case 1.5 : Optional Platform Attributes
PASS
Test Case 1.6 : Enhanced System Power Statistics Attributes
PASS

Tests 2, Basics Test
Test Case 2.1 : Device ID from Management Controller
PASS
Test Case 2.2 : System GUID from Management Controller
PASS
Test Case 2.3 : Asset Tag from UUT
PASS

Tests 3, Cipher Tests
Test Case 3.1 : Checking Supported CipherSuites
PASS

Tests 4, SEL Tests
Test Case 4.1 : Get SEL Info
PASS
Test Case 4.2 : Reserve SEL
PASS
Test Case 4.3 : Get SEL Entry, with Reservation ID
PASS
Test Case 4.4 : Get First SEL Entry after Reservation
PASS
Test Case 4.5 : Get Last SEL Entry and Verify
PASS
Test Case 4.6 : Clear SEL
PASS
Test Case 4.7 : Verify SEL Clear Action
PASS

Tests 5, DCMI Sensor Tests
Test Case 5.1 : Sensors Entity: Inlet (0x40)
PASS
Test Case 5.2 : Sensors Entity: CPU (0x41)
PASS
Test Case 5.3 : Sensors Entity: Baseboard (0x42)
PASS
Test Case 5.4 : Sensor Entity ID: 0x40, Type: 0x1, Instance: 1
PASS
Test Case 5.5 : Sensor Entity ID: 0x41, Type: 0x1, Instance: 1
PASS
Test Case 5.6 : Sensor Entity ID: 0x41, Type: 0x1, Instance: 2
PASS
Test Case 5.7 : Sensor Entity ID: 0x42, Type: 0x1, Instance: 1
PASS
Test Case 5.8 : Sensor Entity ID: 0x42, Type: 0x1, Instance: 2
PASS

Tests 6, DCMI SDR Tests
Test Case 6.1 : Checking SDR Repository Info
PASS

Tests 7, Chassis Commands
Test Case 7.1 : Issue Get Chassis Capabilities Command
PASS
Test Case 7.2 : Checking Chassis Status for Initial Power State
PASS
Test Case 7.3 : Checking Chassis Identify Command supported
PASS
Test Case 7.4 : Check ACPI Power State
PASS
Test Case 7.5 : Check Turn System Off
PASS
Test Case 7.6 : Check Turn System On
PASS
Test Case 7.7 : Check Reboot System
PASS

Tests 8, Verify support for the LAN Configuration Commands
Test Case 8.1 : LAN Support Test
PASS
Test Case 8.2 : VLAN Priority Test
PASS
Test Case 8.3 : VLAN RMCP+ Entry Support
PASS
Test Case 8.4 : VLAN RMCP+ Entries
PASS
Test Case 8.5 : VLAN RMCP+ Privilege level
PASS

Tests 9, DCMI SOL Tests
Test Case 9.1 : Checking Serial Over Lan Configuration
PASS
Test Case 9.2 : Checking SOL Channel Auth. Capabilities
PASS
Test Case 9.3 : Checking SOL Payload Activation - Type SOL
PASS
Test Case 9.4 : Checking SOL Payload Instance Info - Type SOL
PASS

Tests 10, DCMI TMode Tests
Test Case 10.1 : TMODE Support Test

```

```

DCMI 1.5 Conformance Suite

Tests 1, Basic Discovery
Test Case 1.1 : Supported DCMI Platform Capabilities
PASS
Test Case 1.2 : Manageability Access Attributes
PASS
Test Case 1.3 : Session Less Capabilities
PASS
Test Case 1.4 : Minimum Platform Attributes
PASS
Test Case 1.5 : Optional Platform Attributes
PASS
Test Case 1.6 : Enhanced System Power Statistics Attributes
PASS

Tests 2, Basics Test
Test Case 2.1 : Device ID from Management Controller
PASS
Test Case 2.2 : System GUID from Management Controller
PASS
Test Case 2.3 : Asset Tag from UUT
PASS

Tests 3, Cipher Tests
Test Case 3.1 : Checking Supported CipherSuites
PASS

Tests 4, SEL Tests
Test Case 4.1 : Get SEL Info
PASS
Test Case 4.2 : Reserve SEL
PASS
Test Case 4.3 : Get SEL Entry, with Reservation ID
PASS
Test Case 4.4 : Get First SEL Entry after Reservation
PASS
Test Case 4.5 : Get Last SEL Entry and Verify
PASS
Test Case 4.6 : Clear SEL
PASS
Test Case 4.7 : Verify SEL Clear Action
PASS

Tests 5, DCMI Sensor Tests
Test Case 5.1 : Sensors Entity: Inlet (0x40)
PASS
Test Case 5.2 : Sensors Entity: CPU (0x41)
PASS
Test Case 5.3 : Sensors Entity: Baseboard (0x42)
PASS
Test Case 5.4 : Sensor Entity ID: 0x40, Type: 0x1, Instance: 1
PASS
Test Case 5.5 : Sensor Entity ID: 0x41, Type: 0x1, Instance: 1
PASS
Test Case 5.6 : Sensor Entity ID: 0x41, Type: 0x1, Instance: 2
PASS
Test Case 5.7 : Sensor Entity ID: 0x42, Type: 0x1, Instance: 1
PASS
Test Case 5.8 : Sensor Entity ID: 0x42, Type: 0x1, Instance: 2
PASS

Tests 6, DCMI SDR Tests
Test Case 6.1 : Checking SDR Repository Info
PASS

Tests 7, Chassis Commands
Test Case 7.1 : Issue Get Chassis Capabilities Command
PASS
Test Case 7.2 : Checking Chassis Status for Initial Power State
PASS
Test Case 7.3 : Checking Chassis Identify Command supported
PASS
Test Case 7.4 : Check ACPI Power State
PASS
Test Case 7.5 : Check Turn System Off
PASS
Test Case 7.6 : Check Turn System On
PASS
Test Case 7.7 : Check Reboot System
PASS

Tests 8, Verify support for the LAN Configuration Commands
Test Case 8.1 : LAN Support Test
PASS
Test Case 8.2 : VLAN Priority Test
PASS
Test Case 8.3 : VLAN RMCP+ Entry Support
PASS
Test Case 8.4 : VLAN RMCP+ Entries
PASS
Test Case 8.5 : VLAN RMCP+ Privilege level
PASS

Tests 9, DCMI SOL Tests
Test Case 9.1 : Checking Serial Over Lan Configuration
PASS
Test Case 9.2 : Checking SOL Channel Auth. Capabilities
PASS
Test Case 9.3 : Checking SOL Payload Activation - Type SOL
PASS
Test Case 9.4 : Checking SOL Payload Instance Info - Type SOL
PASS

Tests 10, DCMI TMode Tests
Test Case 10.1 : TMODE Support Test
SKIPPED

Tests 11, DCMI Discovery for Power Management Controller Info
Test Case 11.1 : DCMI Get Power Reading
PASS
Test Case 11.2 : DCMI Get Power Limit
PASS

Tests 12, LAN Configuration Check Tests
Test Case 12.1 : Lan Configuration Gratuitous App Check
PASS
Test Case 12.2 : Lan Configuration App Control Check
PASS
Test Case 12.3 : Lan Configuration IP Source Check
PASS
Test Case 12.4 : Lan Configuration Access Mode Check
PASS
Test Case 12.5 : User Access Check
PASS
Test Case 12.6 : Multi-Session test
PASS
Test Case 12.7 : Get MC ID String Test
PASS

Tests 13, Configuration Parameters Test
Test Case 13.1 : Get Active DHCP
PASS
Test Case 13.2 : Get Discovery Configuration
PASS
Test Case 13.3 : Get DHCP Timing 1
PASS
Test Case 13.4 : Get DHCP Timing 2
PASS
Test Case 13.5 : Get DHCP Timing 3
PASS

Tests 14, Thermal Management Tests
Test Case 14.1 : Temperature reading for sensor: Inlet (0x40)
PASS
Test Case 14.2 : Temperature reading for sensor: CPU (0x41)
PASS
Test Case 14.3 : Temperature reading for sensor: Baseboard (0x42)
PASS

```

Figure 2 Sample views

7. Troubleshooting Guide

Issue	Possible Solution
Unable to connect to UUT via RMCP+.	Possible incorrect IP Address in usercfg.cfg file. Unable to ping the UUT using <ping IP Address> Username or Password not in sync for the UUT and the usercfg.cfg file.
Unable to start execution of the KCS/HECI test on the UUT.	Management and monitoring and driver not enabled in the OS.
Test aborts and indicates no DCMI	Controller doesn't support DCMI interface.

Appendix A

This appendix provides in detail the descriptions and variables the user should have knowledge of in preparing to execute the test suite against a DCMI supported server.

```
#####
#       User Configuration File - userconf.cfg
#####
# The User Configuration file defines the Settings for the
# main application, and the RMCPP connection parameters,
# the timeout options of the Platform.
# This file is intended to be changed only if you have a good
# knowledge of the Manageability Controller and Platform
#
# Caution: Please follow the guidelines for initializing
# the following user configurations, any deviations
# will result in unpredictable behavior. All options need to be initialized.
#####

#=====
#[DCMI_Conformance] section defines the following options
# to control the level of information displayed in the Test
# suite to the screen and the file, the name of the result file
# options :
# -> screen-output
# -> log-to-file
# -> log-file-name
#=====

[DCMI_Conformance]
#-----
# Option       : screen-output
# Description   : Defines the level of detail to be printed to current console.
# Valid Options : [no, summary, details, info, warning, debug]
# Usage        : screen-output=summary
#
# Option       : log-to-file
# Description   : Defines the level of detail to be printed to log file.
# Valid Options : [no, summary, details, info, warning, debug]
# Usage        : log-to-file=summary
#
#Both option - the user can choose:
#           no       - log file will not be generated
#           summary- for high level output to file
#           details  - for more detailed output
#           info     - for info level output more detailed than details
#           warning  - for warning messages
#           debug    - prints the raw data command sent to the DCMI and any other information
```

```

#
# Space terminates line, make sure there is no space before and after =
#-----
screen-output=summary

#-----
log-to-file=summary

#-----
# Option      : log-file-name
# Description  : The name of the log file
# Valid Options : valid File name
# Usage       : log-to-file=results.log
# Space terminates line, make sure there is no space before and after =
#-----
log-file-name=results.log

#-----
# Option      : version
# Description  : Forces suit to run in specified DCMI specification mode.
#             If applied application will not be asking for the specification version at the execute stage.
# Valid Options : valid specification version:
#             1.1 - compatibility mode DCMI 1.1
#             1.5 - compatibility mode DCMI 1.5
# Usage       : version=1.1
# Space terminates line, make sure there is no space before and after =
#-----
version=1.1

#=====
# [INBAND] section defines the following options
# to provide the settings for INBAND transport
#
# options :
# DriverName -> The Driver Name or Interface Name to communicate with BMC.
#             Currently supports:
#             - dcmi (for HECI based platform)
#             - Microsoft_IPMI (KCS based platform)
#=====
[INBAND]
DriverName=dcmi

#=====
# [RMCPP] section defines the following options
# to provide the settings for RMCPP transport
#
# options :
# Target IP -> The target IP to establish RMCPP connection

```

```

# Username -> Username of manageability account provisioned in UUT
# Password -> Password corresponding to username
#=====
[RMCPP]
#-----
# Option      : Target IP
# Description  : Target IP of UUT (assigned to BMC)
# Valid Options : Target IP should have following format
#              <xx.xx.xx.xx>. xx should be in decimal.
# Usage       : (ex) targetIP=222.94.222.32
# Space terminates line, make sure there is no space before and after =
#-----
targetIP=192.168.0.100

#-----
# Option      : Username
# Description  : Valid Username provisioned in the BMC. Must be ADMIN
#              to run all tests.
#
# Valid Options : Username can be maximum of 16 characters
# Usage       : (ex) username=username
# Space terminates line, make sure there is no space before and after =
#-----
username=username

#-----
# Option      : CipherSuite
# Description  : The CipherSuite ID as in the Table-4: Mandatory
#              Cipher Suite support
# Valid Options : The valid IDs supported are - 3,8,17
# Usage       : (ex) CipherSuite=8
# Space terminates line, make sure there is no space before and after =
#-----
CipherSuite=3

#=====
# [TimeOutValues] section defines the following options
# to provide platform specific Delay time in seconds required for
# the UUT to stabilise after power off/ power on etc, before
# sending the next command to BMC. The test suite expects these
# time outs to be less than 50 seconds. The tests may fail if the
# time-out delays are not adequate enough for the BMC to stabilize.
# options :
#
# TimeOutPwrOn=25
# TimeOutPwrOff=15
# TimeOutLedBlink=15

```

```
# TimeOutSELReserve=1
# TimeOutSELGet=1
# TimeOutSELClear=1
#=====
```

```
[TimeOutValues]
```

```
#-----
# Option      : TimeOutPwrOn
# Description  : The TimeOutPwrOn is the time in seconds required
#              for the platform to stabilise after a DC ON
#              is issued.
# Valid options : time delay of 1-50. minimal delay of 10 is
#              suggested
# Usage       : (ex)TimeOutPwrOn=30
# Space terminates line, make sure there is no space before and after =
#-----
TimeOutPwrOn=40
```

```
#-----
# Option      : TimeOutPwrOff
# Description  : The TimeOutPwrOff is the time in seconds required
#              for the platform to stabilise after a DC OFF
#              is issued.
# Valid options : time delay of 1-50. minimal delay of 15 is
#              suggested
# Usage       : (ex)TimeOutPwrOff=30
# Space terminates line, make sure there is no space before and# after =
#-----
TimeOutPwrOff=40
```

```
#-----
# Option      : TimeOutLedBlink

# Description  : The TimeOutLedBlink is the time in seconds for
#              blinking the LED in the Chassis Identify command
#              testcase. This is the delay time for user to observe the
#              LED blinking in the platform
# Valid options : time delay of 1-50.
# Usage       : (ex)TimeOutLedBlink=15
# Space terminates line, make sure there is no space before and after =
#-----
TimeOutLedBlink=15
```

```
#-----
# Option      : TimeOutSELReserve
# Description  : The TimeOutSELReserve is the time in seconds
#              for the BMC in the platform to complete a
#              SEL Reserve action
```

```

# Valid options : time delay of 1-50.
# Usage          : (ex)TimeOutSELReserve=1
# Space terminates line, make sure there is no space before and after =
#-----
TimeOutSELReserve=1

#-----
# Option         : TimeOutSELGet
# Description    : The TimeOutSELGet is the time in seconds
#               for the BMC in the platform to complete a SEL Get action
# Valid options : time delay of 1-50.
# Usage          : (ex)TimeOutSELGet=1
# Space terminates line, make sure there is no space before and after =
#-----
TimeOutSELGet=1

#-----
# Option         : TimeOutSELClear
# Description    : The TimeOutSELClear is the time in seconds
#               for the BMC in the platform to complete a SEL Clear action
# Valid options : time delay of 1-50.
# Usage          : (ex)TimeOutSELClear=1
# Space terminates line, make sure there is no space before and after =
#-----
TimeOutSELClear=1

```

Appendix B — Specification Cross Reference

This appendix provides a cross reference map of the line items in the DCM1 specification to the test case number contained in the conformance test suite and brief description of the test case.

DCMI Specification	Test Case Number	Test Case Description
V1.5 V1.1Revision V1.0Reference section.		
	1	Basic Discovery
6.1	1.1	Get DCMI Capabilities Supported DCMI Capabilities
6.1	1.2	Manageability Access Attributes
6.1	1.3	Session Less DCMI Capabilities
6.1	1.4	Minimum Platform Attributes
6.1	1.5	Optional Platform Attributes
6.1	1.6	Enhanced System Power Attribute
	2	Basics Test
6.0, 6.4.2	2.1	Get Device ID
2.5.1, 3, 3.1.1.3, 6,6.4.3	2.2	Get System GUID
2.6, 3, 5.5.1, 6, 6.4.2	2.3	Asset Tag Command
	3	Cipher Test
4 (22.15 ³)	3.1	Supported Cipher Suites
	4	SEL Test
3, 3.1.3, 6, 6.3	4	SEL Check
6, 6.3.1	4.1	Get SEL Info
6, 6.3.2	4.2	Reserve SEL
6.3.2, 6.3.3	4.3	Get SEL Entry with Reservation ID
6.3.2, 6.3.3	4.4	Get First SEL Entry with Reservation ID
6.3.2, 6.3.3	4.5	Get Last SEL Entry with Reservation ID
6, 6.3.4	4.6	Clear SEL
6, 6.3.4	4.7	Verify Clear SEL Action

³ IPMI v2.0

	5	DCMI Sensor Tests
6.1, 6.5, 6.5.1, 6.5.2, 6.5.3, 6.5.4	5.x	Temperature Sensor Discovery: <ul style="list-style-type: none"> • Inlet, • CPU, • Baseboard
	6	DCMI SDR Test
6.5.3	6.1	Checking SDR Repository Info
	7	Chassis Command
6, 6.1	7.1	Issue Get Chassis Capabilities
6, 6.2.2	7.2	Checking Chassis Status for Initial Power State
6, 6.2.3	7.3	Checking Chassis Identify Command supported
6, 6.2.4	7.4	Check ACPI power state
3, 3.1.2, 6, 6.1, 6.2, 6.2.2	7.5	Check Turn System OFF
3, 3.1.2, 6, 6.1, 6.2, 6.2.2	7.6	Check Turn System ON
3, 3.1.2, 6, 6.1, 6.2, 6.2.2	7.7	Check Reboot System
	8	Verify support for the LAN Configuration Commands
5.3.1.2, 6.1, 7.1.1	8.1	VLAN Support Test
	9	DCMI SOL Tests
2.5, 5.2, 5.3.1.2, 5.4.1.3, 6.1, 7	9.1	Checking Serial Over Lan Configuration
2.5, 5.2, 5.3.1.2, 5.4.1.4, 6.1, 7	9.2	Checking SOL Channel Auth. Capabilities
7	9.3	Checking SOL Payload Activation - Type SOL
7	9.4	Checking SOL Payload Instance Info - Type SOL
	10	DCMI TMode Test
2.5, 5.2, 5.3.2.1, 5.4.2.1, 6.1	10.1	TMODE Support Test
	11	DCMI Discovery for Power Management Controller Info
2.5.3, 3, 3.2.1, 6, 6.6, 6.6.1	11.1	DCMI Get Power Reading
2.5.3, 3, 3.2.1, 6, 6.6, 6.6.2	11.2	DCMI Get Power Limit
	12	LAN Configuration Check Tests
5.3.1.2	12.1	Lan Configuration Gratuitous ARP Check
5.3.1.2	12.2	Lan Configuration ARP Control Check
5.3.1.2	12.3	Lan Configuration IP Source Check
5.3.1.2	12.4	Lan Configuration Access Mode Check
5.2, 5.4.1.3	12.5	User Access Check
5.2, 5.4.1.4	12.6	Multi Session Check
6.4.4	12.7	Get MC ID String Test
	13	Configuration Parameters Test
6.1.3	13.1	Get Active DHCP
6.1.3	13.2	Get Discovery Configuration

6.1.3	13.3	Get DHCP Timing 1
6.1.3	13.4	Get DHCP Timing 1
6.1.3	13.5	Get DHCP Timing 1
	14	Thermal Management Tests
6.7.2	14.1	Temperature reading for sensor: Inlet (0x40)
6.7.2	14.2	Temperature reading for sensor: CPU (0x41)
6.7.2	14.3	Temperature reading for sensor: Baseboard (0x42)
	15	Watchdog Timer Tests
	15.1	Get Watchdog Timer

Appendix C – Excerpts from results.log

This appendix shows a sample excerpt from the results.log that will be output by the DCMI conformance test suite for verbose level set to details.

DCMI Conformance Test Suite application started.

```
=====
                        DCMI Conformance Test Suite!
                        ** Tool Revision 1.5.0.26 **
=====
```

Enter a number and <Enter> to chose a specification:

```
1.1      - .....1
1.5      - .....2
EXIT Test .....0
```

-> Enter a number and <Enter> to start the test required:

```
RMCP+    - OOB Test.....1
KCS/HECI - InBand Test (Run on UUT only).....2
Validate RMCP+ CipherSuites Supported on Platform OOB..3
EXIT Test .....0
```

->

Establishing RMCP+ session with CipherSuite: 3

Checking Supported DCMI Capabilities for Platform.

```
Command Request: 0x2c 0 0x1 0xdc 0x1
Command Response: 0 0xdc 0x1 0x5 0x2 0 0x1 0x1
Checking Manageability Access Attributes.
```

```
Command Request: 0x2c 0 0x1 0xdc 0x4
Command Response: 0 0xdc 0x1 0x5 0x2 0x1 0xff 0xff
```

Tests 1, Basic Discovery

```
Test Case 1.1      : Supported DCMI Platform Capabilities
PASS
```

```
Test Case 1.2      : Manageability Access Attributes
PASS
```

```
Test Case 1.3      : Session Less Capabilities
Session Less Test.
```

Checking Supported DCMI Capabilities for Platform.

```
Command Request: 0x2c 0 0x1 0xdc 0x1
Command Response: 0 0xdc 0x1 0x5 0x2 0 0x1 0x1
PASS
```

```
Test Case 1.4      : Minimum Platform Attributes
```

```
Command Request: 0x2c 0 0x1 0xdc 0x2
Command Response: 0 0xdc 0x1 0x5 0x2 0xfe 0xa1 0 0 0x1
PASS
```

```
Test Case 1.5      : Optional Platform Attributes
```

```
Command Request: 0x2c 0 0x1 0xdc 0x3
Command Response: 0 0xdc 0x1 0x5 0x2 0x20 0x2
PASS
```

```
Test Case 1.6      : Enhanced System Power Statistics Attributes
```

```
Command Request: 0x2c 0 0x1 0xdc 0x5
Command Response: 0 0xdc 0x1 0x5 0x2 0x9 0x5 0xf 0x1e 0x41 0x43 0x47 0x4f 0x5e 0x81
```

Tests 5, DCMI Sensor Tests

Test Case 5.1 : Sensors Entity: Inlet (0x40)

Command Request: 0x2c 0 0x7 0xdc 0x1 0x40 0 0
Command Response: 0 0xdc 0x1 0x1 0x7 0x1

PASS

Test Case 5.2 : Sensors Entity: CPU (0x41)

Command Request: 0x2c 0 0x7 0xdc 0x1 0x41 0 0
Command Response: 0 0xdc 0x2 0x2 0x9 0x1 0xa 0x1

PASS

Test Case 5.3 : Sensors Entity: Baseboard (0x42)

Command Request: 0x2c 0 0x7 0xdc 0x1 0x42 0 0
Command Response: 0 0xdc 0x2 0x2 0x1 0x1 0x2 0x1

PASS

Test Case 5.4 : Sensor Entity ID: 0x40, Type: 0x1, Instance: 1

Command Request: 0x2c 0 0x7 0xdc 0x1 0x40 0x1 0x1
Command Response: 0 0xdc 0x1 0x1 0x7 0x1

Command Request: 0xa 0 0x22
Command Response: 0 0x17 0x27

Command Request: 0xa 0 0x23 0x17 0x27 0x7 0x1 0 0x10

Command Response: 0 0x8 0x1 0x7 0x1 0x51 0x1 0x3b 0x20 0 0x7 0x40 0x1 0x37 0xc8 0x1
0x1 0x85 0x32

Command Request: 0xa 0 0x23 0x17 0x27 0x7 0x1 0x10 0x10
Command Response: 0 0x8 0x1 0x85 0x32 0x1b 0x1b 0x80 0x1 0 0 0x1 0 0 0 0 0x7 0x26

Command Request: 0xa 0 0x23 0x17 0x27 0x7 0x1 0x20 0x10
Command Response: 0 0x8 0x1 0x37 0x14 0x7f 0x80 0 0x42 0x3d 0 0x5 0xa 0x2 0x2 0 0 0

0xd0

Command Request: 0x4 0 0x2d 0x7
Command Response: 0 0x18 0xc0 0

Command Request: 0x4 0 0x27 0x7
Command Response: 0 0x1b 0xa 0x5 0 0x3d 0x42 0

PASS

Test Case 5.5 : Sensor Entity ID: 0x41, Type: 0x1, Instance: 1

Command Request: 0x2c 0 0x7 0xdc 0x1 0x41 0x1 0x1
Command Response: 0 0xdc 0x2 0x1 0x9 0x1

Command Request: 0xa 0 0x22
Command Response: 0 0x90 0x27

Command Request: 0xa 0 0x23 0x90 0x27 0x9 0x1 0 0x10

Command Response: 0 0xa 0x1 0x9 0x1 0x51 0x1 0x3b 0x20 0 0x9 0x41 0x1 0x37 0xc8 0x1
0x1 0 0

Command Request: 0xa 0 0x23 0x90 0x27 0x9 0x1 0x10 0x10
Command Response: 0 0xa 0x1 0 0 0 0x80 0x1 0 0 0x1 0 0 0 0 0x7 0xf1

Command Request: 0xa 0 0x23 0x90 0x27 0x9 0x1 0x20 0x10
Command Response: 0 0xa 0x1 0 0xba 0 0xba 0 0 0 0 0x5 0 0 0 0xd0

Command Request: 0x4 0 0x2d 0x9
Command Response: 0 0xd1 0xc0 0

Command Request: 0x4 0 0x27 0x9
Command Response: 0 0 0 0 0 0 0

PASS

Test Case 5.6 : Sensor Entity ID: 0x41, Type: 0x1, Instance: 2

Command Request: 0x2c 0 0x7 0xdc 0x1 0x41 0x2 0x1
Command Response: 0 0xdc 0x2 0x1 0xa 0x1

Command Request: 0xa 0 0x22
Command Response: 0 0x8 0x28

Command Request: 0xa 0 0x23 0x8 0x28 0xa 0x1 0 0x10
Command Response: 0 0x11 0x1 0xa 0x1 0x51 0x1 0x3b 0x20 0 0xa 0x41 0x2 0x37 0xc8 0x1
0x1 0 0

Command Request: 0xa 0 0x23 0x8 0x28 0xa 0x1 0x10 0x10
Command Response: 0 0x11 0x1 0 0 0 0 0x80 0x1 0 0 0x1 0 0 0 0 0x7 0xf1

Command Request: 0xa 0 0x23 0x8 0x28 0xa 0x1 0x20 0x10
Command Response: 0 0x11 0x1 0 0xba 0 0xba 0 0 0 0 0 0 0x5 0 0 0 0xd0

Command Request: 0x4 0 0x2d 0xa
Command Response: 0 0 0xe0

Command Request: 0x4 0 0x27 0xa
Command Response: 0 0 0 0 0 0 0 0

PASS

Test Case 5.7 : Sensor Entity ID: 0x42, Type: 0x1, Instance: 1

Command Request: 0x2c 0 0x7 0xdc 0x1 0x42 0x1 0x1
Command Response: 0 0xdc 0x2 0x1 0x1 0x1

Command Request: 0xa 0 0x22
Command Response: 0 0x7a 0x28

Command Request: 0xa 0 0x23 0x7a 0x28 0x1 0x1 0 0x10
Command Response: 0 0x2 0x1 0x1 0x1 0x51 0x1 0x3b 0x20 0 0x1 0x42 0x1 0x37 0xc8 0x1
0x1 0x85 0x32

Command Request: 0xa 0 0x23 0x7a 0x28 0x1 0x1 0x10 0x10
Command Response: 0 0x2 0x1 0x85 0x32 0x1b 0x1b 0x80 0x1 0 0 0x1 0 0 0 0 0x7 0x26

Command Request: 0xa 0 0x23 0x7a 0x28 0x1 0x1 0x20 0x10
Command Response: 0 0x2 0x1 0x37 0x14 0x7f 0x80 0 0x42 0x3d 0 0x5 0xa 0x2 0x2 0 0 0
0xd0

Command Request: 0x4 0 0x2d 0x1
Command Response: 0 0x16 0xc0 0

Command Request: 0x4 0 0x27 0x1
Command Response: 0 0x1b 0xa 0x5 0 0x3d 0x42 0

PASS

Test Case 5.8 : Sensor Entity ID: 0x42, Type: 0x1, Instance: 2

Command Request: 0x2c 0 0x7 0xdc 0x1 0x42 0x2 0x1
Command Response: 0 0xdc 0x2 0x1 0x2 0x1

Command Request: 0xa 0 0x22
Command Response: 0 0xea 0x28

Command Request: 0xa 0 0x23 0xea 0x28 0x2 0x1 0 0x10
Command Response: 0 0x7 0x1 0x2 0x1 0x51 0x1 0x3b 0x20 0 0x2 0x42 0x2 0x37 0xc8 0x1
0x1 0x85 0x32

Command Request: 0xa 0 0x23 0xea 0x28 0x2 0x1 0x10 0x10
Command Response: 0 0x7 0x1 0x85 0x32 0x1b 0x1b 0x80 0x1 0 0 0x1 0 0 0 0 0x7 0x19

Command Request: 0xa 0 0x23 0xea 0x28 0x2 0x1 0x20 0x10
Command Response: 0 0x7 0x1 0x28 0xa 0x7f 0x80 0 0x30 0x2c 0 0 0x5 0x2 0x2 0 0 0 0xd0

Command Request: 0x4 0 0x2d 0x2
Command Response: 0 0x1c 0xc0 0

Command Request: 0x4 0 0x27 0x2
Command Response: 0 0x1b 0x5 0 0 0x2c 0x30 0

PASS

Tests 6, DCMI SDR Tests

Test Case 6.1 : Checking SDR Repository Info

Command Request: 0xa 0 0x20
Command Response: 0 0x51 0x29 0 0xc0 0x15 0 0 0 0 0 0 0 0 0x2

PASS

Tests 7, Chassis Commands

Test Case 7.1 : Issue Get Chassis Capabilities Command

Command Request: 0 0 0

Command Response: 0 0x1 0x20 0x20 0x20 0x20 0x20

PASS

Test Case 7.2 : Checking Chassis Status for Initial Power State

Command Request: 0 0 0x1

Command Response: 0 0x41 0x11 0x48 0

PASS

Test Case 7.3 : Checking Chassis Identify Command supported

Command Request: 0 0 0x4 0 0x1

Command Response: 0

Command Request: 0 0 0x4 0 0

Command Response: 0

PASS

Test Case 7.4 : Check ACPI Power State

Command Request: 0 0 0x1

Command Response: 0 0x41 0x11 0x48 0

Command Request: 0x6 0 0x7

Command Response: 0 0x20 0

Command Request: 0 0 0x2 0

Command Response: 0

Command Request: 0x6 0 0x7

Command Response: 0 0x5 0x1

Command Request: 0 0 0x2 0x1

Command Response: 0

PASS

Test Case 7.5 : Check Turn System Off

Command Request: 0 0 0x2 0

Command Response: 0

PASS

Test Case 7.6 : Check Turn System On

Command Request: 0 0 0x2 0x1

Command Response: 0

PASS

Test Case 7.7 : Check Reboot System

Command Request: 0 0 0x2 0x2

Command Response: 0

PASS

Tests 8, Verify support for the LAN Configuration Commands

Test Case 8.1 : VLAN Support Test

Command Request: 0xc 0 0x2 0x1 0x14 0 0

Command Response: 0 0x11 0 0

PASS

Test Case 8.2 : VLAN Priority Test

Command Request: 0xc 0 0x2 0x1 0x15 0 0

Command Response: 0 0x11 0

PASS

Test Case 8.3 : VLAN RMCPP+ Entry Support

Command Request: 0xc 0 0x2 0x1 0x16 0 0

Command Response: 0 0x11 0x3

PASS

Test Case 8.4 : VLAN RMCPP+ Entries

Command Request: 0xc 0 0x2 0x1 0x17 0 0

Command Response: 0 0x11 0 0x3 0x8 0x11

```

PASS
Test Case 8.5      : VLAN RMCPP+ Privilege level

    Command Request: 0xc 0 0x2 0x1 0x18 0 0
    Command Response: 0 0x11 0 0x44 0x4 0 0 0 0 0 0
PASS

Tests 9, DDMI SOL Tests
Test Case 9.1     : Checking Serial Over Lan Configuration

    Command Request: 0xc 0 0x22 0x1 0 0 0
    Command Response: 0 0x11 0

    Command Request: 0xc 0 0x22 0x1 0x1 0 0
    Command Response: 0 0x11 0x1

    Command Request: 0xc 0 0x22 0x1 0x2 0 0
    Command Response: 0 0x11 0xc4

    Command Request: 0xc 0 0x22 0x1 0x3 0 0
    Command Response: 0 0x11 0x6 0x20

    Command Request: 0xc 0 0x22 0x1 0x4 0 0
    Command Response: 0 0x11 0x5 0x64

    Command Request: 0xc 0 0x22 0x1 0x5 0 0
    Command Response: 0 0x11 0xa

    Command Request: 0xc 0 0x22 0x1 0x6 0 0
    Command Response: 0 0x11 0xa
PASS
Test Case 9.2     : Checking SOL Channel Auth. Capabilities

    Command Request: 0x6 0 0x38 0x81 0x4
    Command Response: 0 0x1 0x84 0x4 0x3 0 0 0 0
PASS
Test Case 9.3     : Checking SOL Payload Activation - Type SOL

    Command Request: 0x6 0 0x4a 0x1
    Command Response: 0 0x1 0 0
PASS
Test Case 9.4     : Checking SOL Payload Instance Info - Type SOL

    Command Request: 0x6 0 0x4b 0x1 0x1
    Command Response: 0 0 0 0 0 0x1 0 0 0 0 0 0 0
PASS

Tests 10, DDMI TMode Tests
Test Case 10.1    : TMODE Support Test
    SKIPPED

Tests 11, DDMI Discovery for Power Management Controller Info
Test Case 11.1   : DDMI Get Power Reading

    Command Request: 0x2c 0 0x2 0xdc 0x1 0 0
    Command Response: 0 0xdc 0 0 0 0 0 0 0 0 0xa0 0x41 0xc5 0x4e 0x58 0x91 0x16 0 0x40
PASS
Test Case 11.2   : DDMI Get Power Limit

    Command Request: 0x2c 0 0x3 0xdc 0 0
    Command Response: 0x80 0xdc 0 0 0x11 0x40 0 0xff 0xff 0 0 0 0 0xff 0
PASS

Tests 12, LAN Configuration Check Tests
Test Case 12.1   : Lan Configuration Gratuitous Arp Check

    Command Request: 0xc 0 0x2 0x1 0xa 0 0
    Command Response: 0 0x11 0x2
PASS
Test Case 12.2   : Lan Configuration Arp Control Check

    Command Request: 0xc 0 0x2 0x1 0xa 0 0
    Command Response: 0 0x11 0x2

```

Command Request: 0x2c 0 0x10 0xdc 0x1 0x41 0 0
Command Response: 0 0xdc 0x2 0x1 0xb5 0x1

PASS

Test Case 14.3 : Temperature reading for sensor: Baseboard (0x42)

Command Request: 0x2c 0 0x10 0xdc 0x1 0x42 0 0
Command Response: 0 0xdc 0x2 0x2 0x16 0x1 0x1a 0x2

PASS

DCMI 1.5 Conformance Suite

Tests 1, Basic Discovery

Test Case 1.1	: Supported DCMI Platform Capabilities	PASS
Test Case 1.2	: Manageability Access Attributes	PASS
Test Case 1.3	: Session Less Capabilities	PASS
Test Case 1.4	: Minimum Platform Attributes	PASS
Test Case 1.5	: Optional Platform Attributes	PASS
Test Case 1.6	: Enhanced System Power Statistics Attributes	PASS

Tests 2, Basics Test

Test Case 2.1	: Device ID from Management Controller	PASS
Test Case 2.2	: System GUID from Management Controller	PASS
Test Case 2.3	: Asset Tag from UUT	PASS

Tests 3, Cipher Tests

Test Case 3.1	: Checking Supported CipherSuites	PASS
---------------	-----------------------------------	------

Tests 4, SEL Tests

Test Case 4.1	: Get SEL Info	PASS
Test Case 4.2	: Reserve SEL	PASS
Test Case 4.3	: Get SEL Entry, with Reservation ID	PASS
Test Case 4.4	: Get First SEL Entry after Reservation	PASS
Test Case 4.5	: Get Last SEL Entry and Verify	PASS
Test Case 4.6	: Clear SEL	PASS
Test Case 4.7	: Verify SEL Clear Action	PASS

Tests 5, DCMI Sensor Tests

Test Case 5.1	: Sensors Entity: Inlet (0x40)	PASS
Test Case 5.2	: Sensors Entity: CPU (0x41)	PASS
Test Case 5.3	: Sensors Entity: Baseboard (0x42)	PASS
Test Case 5.4	: Sensor Entity ID: 0x40, Type: 0x1, Instance: 1	PASS
Test Case 5.5	: Sensor Entity ID: 0x41, Type: 0x1, Instance: 1	PASS
Test Case 5.6	: Sensor Entity ID: 0x41, Type: 0x1, Instance: 2	PASS
Test Case 5.7	: Sensor Entity ID: 0x42, Type: 0x1, Instance: 1	PASS
Test Case 5.8	: Sensor Entity ID: 0x42, Type: 0x1, Instance: 2	PASS

Tests 6, DCMI SDR Tests

Test Case 6.1	: Checking SDR Repository Info	PASS
---------------	--------------------------------	------

Tests 7, Chassis Commands

Test Case 7.1	: Issue Get Chassis Capabilities Command	PASS
Test Case 7.2	: Checking Chassis Status for Initial Power State	PASS
Test Case 7.3	: Checking Chassis Identify Command supported	PASS
Test Case 7.4	: Check ACPI Power State	PASS
Test Case 7.5	: Check Turn System Off	PASS
Test Case 7.6	: Check Turn System On	PASS
Test Case 7.7	: Check Reboot System	PASS

Tests 8, Verify support for the LAN Configuration Commands

Test Case 8.1	: VLAN Support Test	PASS
Test Case 8.2	: VLAN Priority Test	PASS
Test Case 8.3	: VLAN RMCPP+ Entry Support	PASS
Test Case 8.4	: VLAN RMCPP+ Entries	PASS
Test Case 8.5	: VLAN RMCPP+ Privilege level	PASS

Tests 9, DCMI SOL Tests

Test Case 9.1	: Checking Serial Over Lan Configuration	PASS
Test Case 9.2	: Checking SOL Channel Auth. Capabilities	PASS

Test Case 9.3	: Checking SOL Payload Activation - Type SOL	PASS
Test Case 9.4	: Checking SOL Payload Instance Info - Type SOL	PASS
Tests 10, DCMI TMode Tests		
Test Case 10.1	: TMODE Support Test	SKIPPED
Tests 11, DCMI Discovery for Power Management Controller Info		
Test Case 11.1	: DCMI Get Power Reading	PASS
Test Case 11.2	: DCMI Get Power Limit	PASS
Tests 12, LAN Configuration Check Tests		
Test Case 12.1	: Lan Configuration Gratuitous Arp Check	PASS
Test Case 12.2	: Lan Configuration Arp Control Check	PASS
Test Case 12.3	: Lan Configuration IP Source Check	PASS
Test Case 12.4	: Lan Configuration Access Mode Check	PASS
Test Case 12.5	: User Access Check	PASS
Test Case 12.6	: Multi Session Test	PASS
Test Case 12.7	: Get MC ID String Test	PASS
Tests 13, Configuration Parameters Test		
Test Case 13.1	: Get Active DHCP	PASS
Test Case 13.2	: Get Discovery Configuration	PASS
Test Case 13.3	: Get DHCP Timing 1	PASS
Test Case 13.4	: Get DHCP Timing 2	PASS
Test Case 13.5	: Get DHCP Timing 3	PASS
Tests 14, Thermal Management Tests		
Test Case 14.1	: Temperature reading for sensor: Inlet (0x40)	PASS
Test Case 14.2	: Temperature reading for sensor: CPU (0x41)	PASS
Test Case 14.3	: Temperature reading for sensor: Baseboard (0x42)	PASS