



Intel[®] 41210 Serial to Parallel PCI Bridge Evaluation Board

User's Guide

October 2004

Order Number: [278947-002](#)





INFORMATION IN THIS DOCUMENT IS PROVIDED IN CONNECTION WITH INTEL® PRODUCTS. NO LICENSE, EXPRESS OR IMPLIED, BY ESTOPPEL OR OTHERWISE, TO ANY INTELLECTUAL PROPERTY RIGHTS IS GRANTED BY THIS DOCUMENT. EXCEPT AS PROVIDED IN INTEL'S TERMS AND CONDITIONS OF SALE FOR SUCH PRODUCTS, INTEL ASSUMES NO LIABILITY WHATSOEVER, AND INTEL DISCLAIMS ANY EXPRESS OR IMPLIED WARRANTY, RELATING TO SALE AND/OR USE OF INTEL PRODUCTS INCLUDING LIABILITY OR WARRANTIES RELATING TO FITNESS FOR A PARTICULAR PURPOSE, MERCHANTABILITY, OR INFRINGEMENT OF ANY PATENT, COPYRIGHT OR OTHER INTELLECTUAL PROPERTY RIGHT. Intel products are not intended for use in medical, life saving, life sustaining applications.

Intel may make changes to specifications and product descriptions at any time, without notice.

The Intel® 41210 Serial to Parallel PCI Bridge may contain design defects or errors known as errata which may cause the product to deviate from published specifications. Current characterized errata are available on request.

Contact your local Intel sales office or your distributor to obtain the latest specifications and before placing your product order.

Copies of documents which have an ordering number and are referenced in this document, or other Intel literature may be obtained by calling 1-800-548-4725 or by visiting Intel's website at <http://www.intel.com>.

Intel is a trademark or registered trademark of Intel Corporation or its subsidiaries in the United States and other countries.

*Other names and brands may be claimed as the property of others.

Copyright © 2004, Intel Corporation

Contents

1.0 Introduction	5
2.0 Overview	5
3.0 Features	5
4.0 Major Components	6
5.0 DIP Switches	7

Figures

1 Major Components Overview	6
2 Switches, Jumpers, and Connectors Location.....	7

Tables

1 DIP Switch Operation, PCI-X and PCI Clock Frequency.....	8
2 DIP Switch Operation, SMBUS ADDRESS.....	8
3 Jumper Connections, JTAG Port.....	9
4 Jumper Connections, Microcontroller I2C interface.....	9
5 Jumper Connections, GNT “A” and “B” Header.....	9
6 Jumper Connections, REQ “A” and “B” Header.....	10
7 Jumper Connections, J13, J14 and J17	10
8 Jumper Connections, QSWITCH EN Header	10

Revision History

Date	Revision	Description
October 2004	002	-Updated naming terminology in Sections 2.0 and 3.0. -Corrected PCI Bus name Header Connectors J5 and J6 in Section 4.0. -Corrected Switch S3 and S4 PCI-X 66 MHZ Pos 3 settings in Table 1.
December 2003	001	This is the first release of this document.

1.0 Introduction

This document describes the Intel® 41210 Serial to Parallel PCI Bridge (also called 41210 Bridge) Evaluation Board.

2.0 Overview

The Intel® 41210 Serial to Parallel PCI Bridge evaluation board is a PCI-Express enabling tool with PCI-X expansion slots that are used to evaluate the operation of the 41210 Bridge. The 41210 Bridge evaluation board can be used to perform the following functions:

- Develop initialization code to configure the 41210 Bridge and associated logic and devices on the local PCI-X bus as a intelligent controller.
- Evaluate the operation of the 41210 Bridge with a variety of PCI/PCI-X devices configured in an intelligent subsystem.
- Build and evaluate a system.
- Testing of the 41210 Bridge feature set.

3.0 Features

The 41210 Bridge evaluation board has the following features:

- Complies fully with:
 - Protocol and electrical standards of the *PCI Local Bus Specification*, Revision 2.3
 - *PCI-X Bridge Architecture*, Rev 1.0 B
 - *PCI-Express Base Specification*, Rev 1.0A
 - *PCI-Express Card Electrical Mechanical Specification*
 - *PCI-Express Bridge Specification*.
- Includes a 41210 "transparent" PCI-X Enhanced PCI-to-PCI Bridge that provides bridging between two processor domains.
- Includes a host PCI-Express interface that plugs into any x8 PCI-Express option card slot.
- Provides dual peer PCI-X 133 MHz slots on separate bus segments in addition to each having a segregated PCI-X100/66 MHz slot
- Three MICTOR LA connectors for logic analyzer interfacing of each bus segment
- Support, Products, and Documentation

4.0 Major Components

The major components for the 41210 Bridge include:

- For the A Secondary:
 - J11 is the PCI-X 100/66 MHz card slot.
 - J7 is the PCI-X 133 MHz card slot.
- For the B Secondary:
 - J12 is the PCI-X 100/66 MHz card slot.
 - J8 is the PCI-X 133 MHz card slot.
- MICTOR connectors U14-17 and U19-20 provide test points for the 64-bit S_AD signals.
- Header Connectors J3 and J4 provides test points for the PCI Bus A REQ/GNT signals.
- Header Connectors J5 and J6 provides test points for the PCI Bus B REQ/GNT signals.
- J1 is the JTAG connector.
- J15 provides access to the Microcontroller
- S1, S3, S4, are option switches.

Figure 1. Major Components Overview

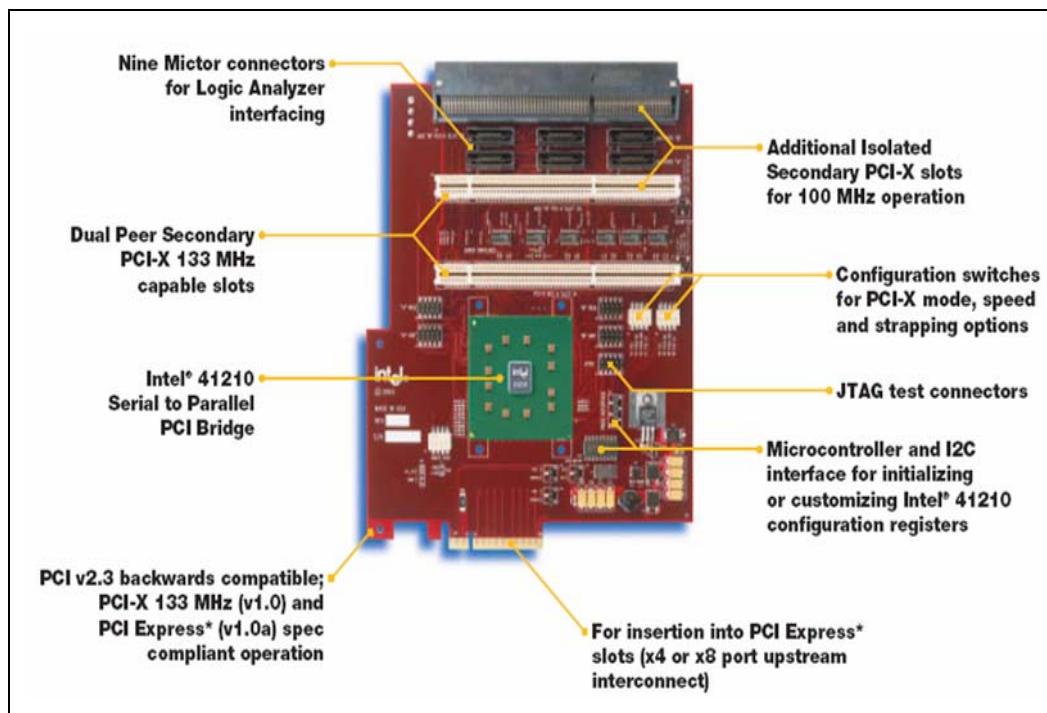

5.0 DIP Switches

The 41210 Bridge uses a combination of switches and jumpers to control the various configuration options. The following sections describe these controls.

Figure 2. Switches, Jumpers, and Connectors Location

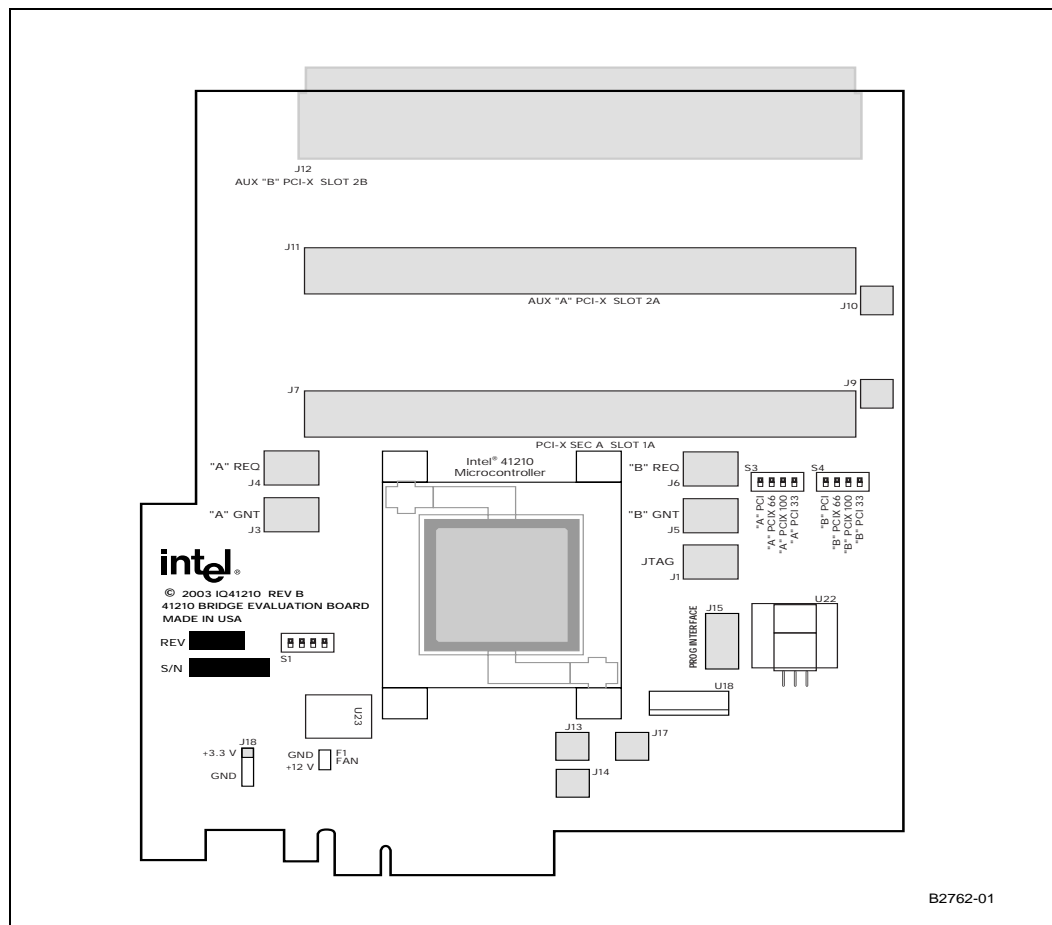

5.0.1 Switch Settings

Table 1 and Table 2 describe the functions of the 41210 Bridge Evaluation Board switches. The switches should be set before powering up the system. Figure 2 shows the Evaluation board switches.

Note: When a switch is ON, it is Closed.

Table 1. DIP Switch Operation, PCI-X and PCI Clock Frequency

Switch	Function	Pos 1	Pos 2	Pos 3	Pos 4
S3	Selects Secondary A PCI-X 133 MHz	Open	Open	Open	NA
S3	Selects Secondary A PCI-X 100 MHz	Open	Open	Closed	NA
S3	Selects Secondary A PCI-X 66 MHz	Open	Open	Closed	NA
S3	Selects Secondary A PCI 66 MHz	Closed	NA	NA	Open
S3	Selects Secondary A PCI 33 MHz	Closed	NA	NA	Closed
S4	Selects Secondary B PCI-X 133 MHz	Open	Open	Open	NA
S4	Selects Secondary B PCI-X 100 MHz	Open	Open	Closed	NA
S4	Selects Secondary B PCI-X 66 MHz	Open	Open	Closed	NA
S4	Selects Secondary B PCI 66 MHz	Closed	NA	NA	Open
S4	Selects Secondary B PCI 33 MHz	Closed	NA	NA	Closed

Table 2. DIP Switch Operation, SMBUS ADDRESS

Switch	Function	Pos 1-4
S1	All 1's	Open
S4	All 0's	CLOSED

Note: **BOLD** settings are Defaults.

5.1 Jumpers

In addition to the DIP switches, the 41210 Bridge provides stake-pin jumpers for selecting special features. The jumpers can be used for debugging and for evaluating special features. [Table 3](#) through [Table 8](#) show the configuration jumpers and the jumper function. [Figure 2](#) shows the 41210 Evaluation Board jumpers.

Table 3. Jumper Connections, JTAG Port

Jumper	Function	Default
J1-2,1	TCK Test Clock	<i>Not Installed</i>
J1-4,3	TDO Test Data Out	<i>Not Installed</i>
J1-6,5	TDI Test Data In	<i>Not Installed</i>
J1-8,7	TMS Test Mode Select	<i>Not Installed</i>
J1-10,9	TRST# Test Reset	<i>Not Installed</i>
J1-1,3,5,7,9	GND	
J1-11,12	NC	

Table 4. Jumper Connections, Microcontroller I2C interface

Jumper	Function
J15-1	MPP/CLR
J15-2	VDD
J15-3	GND
J15-4	RB(7) (dat)
J15-5	RB(6)(Clk)
J15-6	nc

Table 5. Jumper Connections, GNT “A” and “B” Header

Jumper	Function	Position	Default
J3 & 5-1,2	GNT4	1	Not Installed
J3 & 5-3,4	GNT3	2	Not Installed
J3 & 5-5,6	GNT2	3	Installed
J3 & 5-7,8	GNT1	4	Installed
J3 & 5-9,10	GNT0	5	Installed
J7-2,4,6,8,10	GND		
J7-11,12	NC		

Table 6. Jumper Connections, REQ “A” and “B” Header

Jumper	Function	Position	Default
J4 & 6-1,2	REQ4	1	Not Installed
J4 & 6-3,4	REQ3	2	Not Installed
J4 & 6-5,6	REQ2	3	Installed
J4 & 6-7,8	REQ1	4	Installed
J4 & 6-9,10	REQ0	5	Installed
J7-2,4,6,8,10	GND		
J7-11,12	NC		

Table 7. Jumper Connections, J13, J14 and J17

Function	Normal Installed	Test mode
SMDAT	J13-1 to J13-2	J13-2 to J13-3
SMCLK	J14-1 to J14-2	J14-2 to J14-3
CFGRETRY	J17-1 to J17-2	J17-2 to J17-3

Note: When selecting External Oscillator Source, source can be connected to the J8 BNC.

Note: **BOLD** settings are Defaults.

Table 8. Jumper Connections, QSWITCH EN Header

Function	Installed	Not Installed
For 133 MHz Operation	J9 &10-1 to J9 &10-2	J9 &10-3
Enables 2nd PCI/PCI-X Connector & MICTOR LA Connectors	J9 &10-2 to J9 &10-3	J9 &10-1

Note: J9 and J10 straps the QSWITCHEN# line.

Note: **BOLD** settings are Defaults.