



AP-903

**APPLICATION
NOTE**

Mechanical Assembly and Customer Manufacturing Technology for S.E.C.C.2 Package Processors

February 1999

Order Number: 244457-001

Information in this document is provided in connection with Intel products. No license, express or implied, by estoppel or otherwise, to any intellectual property rights is granted by this document. Except as provided in Intel's Terms and Conditions of Sale for such products, Intel assumes no liability whatsoever, and Intel disclaims any express or implied warranty, relating to sale and/or use of Intel products including liability or warranties relating to fitness for a particular purpose, merchantability, or infringement of any patent, copyright or other intellectual property right. Intel products are not intended for use in medical, life saving, or life sustaining applications.

Intel may make changes to specifications and product descriptions at any time, without notice.

Designers must not rely on the absence or characteristics of any features or instructions marked "reserved" or "undefined." Intel reserves these for future definition and shall have no responsibility whatsoever for conflicts or incompatibilities arising from future changes to them.

The Pentium® II processor and Pentium III processor may contain design defects or errors known as errata which may cause the product to deviate from published specifications. Current characterized errata are available on request.

Contact your local Intel sales office or your distributor to obtain the latest specifications and before placing your product order.

Copies of documents which have an ordering number and are referenced in this document, or other Intel literature, may be obtained by calling 1-800-548-4725 or by visiting Intel's website at <http://www.intel.com>

Copyright © Intel Corporation 1999.

* Third-party brands and names are the property of their respective owners.

CONTENTS

	PAGE		PAGE
1. 0.INTRODUCTION	7	3.3.2. S.E.C.C.2 PACKAGE HEAT SINK CLIP DESIGN CONSIDERATIONS	21
1.1. Purpose of this Document	7	3.4. S.E.C.C.2 Heat Sink Mechanical Requirements	21
1.2. References.....	8	3.5. Retention Mechanism Mechanical Description	24
2. 0.SINGLE EDGE CONTACT CARTRIDGE 2 PACKAGE	8	4.0. BASEBOARD INTEGRATION MANUFACTURING GUIDELINES	25
2.1. S.E.C.C.2 Package Terminology	8	4.1. Introduction and Suggested Integration Flow	25
2.2. S.E.C.C.2 Package Design and Construction.....	9	4.1.1. RECOMMENDED SC242 CONNECTOR INSERTION STEPS AND REQUIREMENTS	27
2.2.1. S.E.C.C.2 PACKAGE ASSEMBLY	9	4.2. Retention Mechanism Attach Mount Installation	28
2.2.2. S.E.C.C.2 PACKAGE SUBSTRATE.....	10	4.2.1. ATTACH MOUNT ASSEMBLY CRITERIA	30
2.2.3. PROCESSOR CORE PACKAGE	12	5.0. SYSTEM INTEGRATION MANUFACTURING GUIDELINES	30
2.2.4. BSRAM.....	12	5.1. Introduction and Suggested Integration Flow	30
2.2.5. COVER.....	12	5.2. Heat Sink Attachment to the Processor Core and S.E.C.C.2 Cover.....	31
2.3. Package Handling and Shipping Media.....	12	5.2.1. HEAT SINK ATTACHMENT USING REFERENCE TOOLING	32
2.3.1. S.E.C.C.2 PACKAGE HANDLING PRECAUTIONS FOR ESD PROTECTION.....	12	5.3. Baseboard Preparation	35
2.3.2. S.E.C.C.2 PACKAGE HANDLING PRECAUTIONS	12	5.3.1. MANUAL INSTALLATION OF THE CAPTIVE FASTENER RETENTION MECHANISMS.....	35
2.3.3. PACKAGE ENABLING.....	13	5.3.2. MANUAL INSTALLATION OF THE PLASTIC FASTENER RETENTION MECHANISMS.....	35
2.3.4. RETENTION MECHANISM	13	5.3.3. INSTALLATION OF THE PROCESSOR/HEAT SINK ASSEMBLY.....	35
2.3.5. THERMAL INTERFACE MATERIAL.....	13	5.3.4. HVM REFERENCE PROCEDURES AND EQUIPMENT FOR THE REFERENCE RETENTION MECHANISM.....	35
2.3.6. HEAT SINK AND HEAT SINK ATTACHMENT	13	5.3.5. OTHER SYSTEM AND BASEBOARD ASSEMBLY ISSUES	36
2.3.7. PENTIUM® II PROCESSOR SHIPPING MEDIA DESCRIPTION AND SPECIFICATIONS.....	13	5.4. Removal of Processor and Mechanical Support Components	36
2.4. S.E.C.C.2 Package Quality and Reliability ..	14		
2.5. S.E.C.C.2 Package Change Control	14		
2.6. S.E.C.C.2 Package Marking.....	14		
2.7. S.E.C.C.2 Package Processor Return Procedure	15		
3.0. S.E.C.C.2 PACKAGE MECHANICAL SUPPORT COMPONENTS	16		
3.1. SC242 Connector	18		
3.2. Retention Mechanism Attach Mount.....	19		
3.3. Heat Sink Retention Clip.....	21		
3.3.1. HEAT SINK RETENTION CLIP	21		

- 5.4.1. REMOVING THE PROCESSOR36
- 5.4.2. REMOVAL OF THE CAPTIVE FASTENER RETENTION MECHANISM.....36
- 5.4.3. REMOVAL OF THE PLASTIC FASTENER RETENTION MECHANISM.....36
- 5.5. Reuse of Processor and Mechanical Support Components37
- 6. 0.INTEL BOXED PROCESSOR INTEGRATION GUIDELINES.....37**
- 6.1. Boxed Processor Fan Heat Sink.....38
- 6.2. Boxed Processor Mechanical and Electrical Support Components38
 - 6.2.1. RETENTION MECHANISM.....38
 - 6.2.2. FAN POWER CABLE38
- 6.3. Boxed Processor System Integration Manufacturing Guidelines.....39
 - 6.3.1. PRE-INSTALLATION PREPARATION39
 - 6.3.2. BASEBOARD PREPARATION – INSTALLATION OF THE RETENTION MECHANISM.....39
 - 6.3.3. INSTALLING THE BOXED PROCESSOR.....40
 - 6.3.4. REMOVING THE BOXED PROCESSOR.....40

FIGURES

- Figure 1. Single Edge Contact Cartridge 2 Package7
- Figure 2. S.E.C.C.2 Package — Substrate and Cover Side Views.....9
- Figure 3. Exploded View of S.E.C.C.2 Package10
- Figure 4. S.E.C.C.2 Package with OLGA Core and L2 Cache11
- Figure 5. S.E.C.C.2 Package with PLGA Core and L2 Cache11
- Figure 6. Substrate Edge Finger Contact and Key Detail12
- Figure 7. Pentium® II Processor Shipping Box ..13
- Figure 8. Processor Markings15
- Figure 9. S.E.C.C.2 Package with All Mechanical Support Components, Full Assembly.....17
- Figure 10. Exploded View of S.E.C.C.2 Package with All Mechanical Support Components....18

- Figure 11. Baseboard Retention Mechanism, SC242 Connector Recommended Hole Locations and Sizes 19
- Figure 12. SC242 Connector 19
- Figure 13. Retention Mechanism Attach Mount Assembly 20
- Figure 14. Retention Mechanism Attach Mount Baseboard Interaction Details 20
- Figure 15. Reference Design for Heat Sink Retention Clip 21
- Figure 16. Retention Mechanism Features to interface Heat Sink 22
- Figure 17. Heat Sink to Thermal Interface Attachment Requirements 23
- Figure 18. Heat Sink Requirements for Use with Reference Design Retention Clip 24
- Figure 19. SEPP Retention Mechanism, Exploded View 25
- Figure 20. Universal Retention Mechanism..... 25
- Figure 21. Suggested Baseboard/System Integration Manufacturing Flow 26
- Figure 22. SC242 Connector, Retention Features Highlighted..... 27
- Figure 23. SC242 Connector Mounted in Baseboard 28
- Figure 24. Recommended Process Capability to Ensure Correct Interaction of S.E.C.C.2 Package and Mechanical Support Components 29
- Figure 25. ATX Baseboard with SC242 Connector and RMAM Installed..... 29
- Figure 26. Attach Mount Installed in Baseboard. 30
- Figure 27. Suggested Baseboard/System Integration Manufacturing Flow 31
- Figure 28. Heat Sink Attach Fixture, Open..... 32
- Figure 29. Position the Processor on the Tool ... 33
- Figure 30. Heat Sink and Heat Sink Retention Clip Placement..... 33
- Figure 31. Pressing the Retention Clips into the Cover 34
- Figure 32. Assembled Processor and Heat Sink..... 34
- Figure 33. Installation of the Captive Fastener Retention Mechanism..... 35
- Figure 34. Installation of the Plastic Fastener Retention Mechanism..... 35
- Figure 35. Plastic Fastener Installation/Extraction Tool 36

Figure 36. Position Installation/Extraction Tool...	37
Figure 37. Pull Up Gently	37
Figure 38. Rotate Up	37
Figure 39 S.E.C.C.2 Package Boxed Processor	38
Figure 40. Suggested System Integration Manufacturing Flow.....	39

TABLES

Table 1. Environmental Test Conditions for S.E.C.C.2 Package	14
Table 2. Description Table for Processor Markings.....	15
Table 3. S.E.C.C.2 Package Reference Mechanical Solution and Materials List.....	26
Table 4. S.E.C.C.2 Package Reference Mechanical Solution and Materials List	31
Table 5. S.E.C.C.2 Boxed Processor System Assembly and Material List	39

1.0. INTRODUCTION

The Pentium® II and Pentium III processors are the next in the IA-32 architecture of Intel processors. These processors, like the Pentium Pro processor, implement a Dynamic Execution micro-architecture — a unique combination of multiple branch prediction, data flow analysis and speculative execution. This enables the Pentium II processor and Pentium III processor to deliver higher performance than the Pentium processor, while maintaining binary compatibility with all previous Intel architecture processors. The Pentium II processor also executes MMX™ technology instructions for enhanced media and communication performance, while the Pentium III also includes the Streaming SIMD Extensions. These processors utilize multiple low-power states such as AutoHALT, Stop-Grant, Sleep and Deep Sleep to conserve power during idle times.

With the Pentium II processor, Intel introduced the S.E.C.C. package to ensure performance growth into future generations. The introduction of the Single Edge Contact Cartridge 2 (S.E.C.C.2) package technology ensures the Pentium II and future Intel processor can

handle the increasing demands for power from businesses and consumers interested in the new world of multimedia (see Figure 1).

The S.E.C.C.2 package, like the Single Edge Contact Cartridge (S.E.C.C.) package, combines a processor core, along with other devices mounted on the substrate.

The introduction of the S.E.C.C.2 package technology continues the commitment to providing packaging solutions which meet Intel's rigorous criteria for quality and performance.

1.1. Purpose of this Document

This application note is meant to familiarize the reader with the S.E.C.C.2 package technology developed by Intel and related issues for the Personal Computer Original Equipment Manufacturer (PC OEM) The first section will detail the manufacturing technology used by Intel for the S.E.C.C.2 package. The second half of the document will describe a reference mechanical solution for use in PC OEM systems and impacts that solution has on the PC OEM manufacturing process.

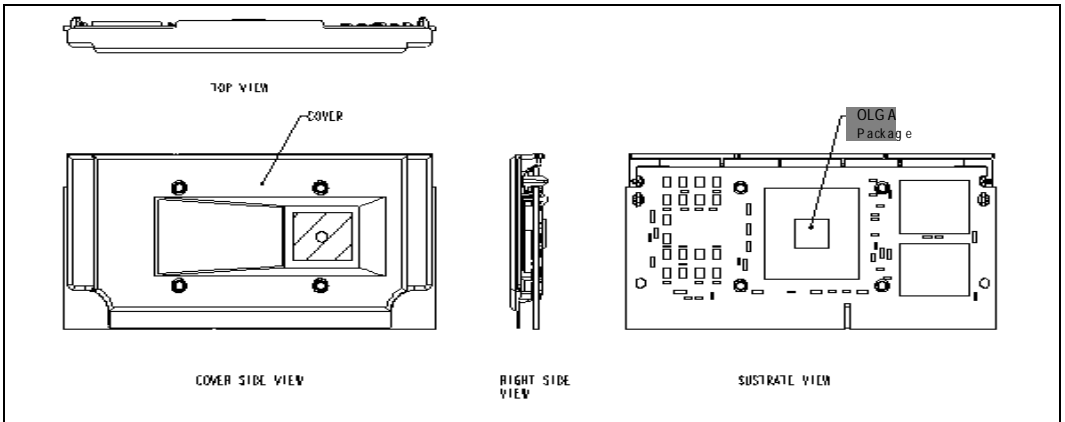

Figure 1. Single Edge Contact Cartridge 2 Package

1.2. References

The reader of this specification should also consult the Intel Developer's website at: <http://developer.intel.com/design/processor/> for the latest Intel processor information. The web page at the following URL: <http://developer.intel.com/design/pentiumiii/packtech/> is specific to the S.E.C.C.2 package. This site is constantly being updated with new information. All of the documents referenced in this document are available on these websites.

2.0. SINGLE EDGE CONTACT CARTRIDGE 2 PACKAGE

The Pentium II processor is the first microprocessor product from Intel Corporation to utilize the Single Edge Contact (S.E.C.C.2) cartridge packaging technology. The S.E.C.C.2 package utilizes surface mount technology and a substrate with an edge finger connection.

The S.E.C.C.2 package has the following features:, a cover and a substrate with the SC242 edge finger connection.

In the transition from the S.E.C.C. package to the S.E.C.C.2 package the following items were removed: thermal plate, skirt, and latches. In addition the cover was redesigned to allow a new heat sink retention scheme. By eliminating the thermal plate the OEM has a more direct thermal solution to the processor core.

The edge finger connection maintains socketability for system configuration. The edge finger connection uses a

connector that is noted as the SC242 connector in this and other documentation.

2.1. S.E.C.C.2 Package Terminology

The following terms are used often in this document and are explained here for clarification (see Figure 2).

- **Processor** — The entire product including internal components, substrate, and cover.
- **S.E.C.C.2 package** — The processor packaging technology is called a “Single Edge Contact Cartridge 2.”
- **Processor substrate** —The structure on which the components are mounted inside the S.E.C.C.2 package (with or without components attached).
- **Processor core** — The processor's execution engine
- **OLGA** — Organic Land Grid Array. This processor core package technology permits attaching the heat sink directly to the die.
- **PLGA** — Plastic Land Grid Array. This processor core package technology permits attaching the heat sink to a cover.
- **Cover** — The processor casing on the opposite side of the substrate from the processor core package.

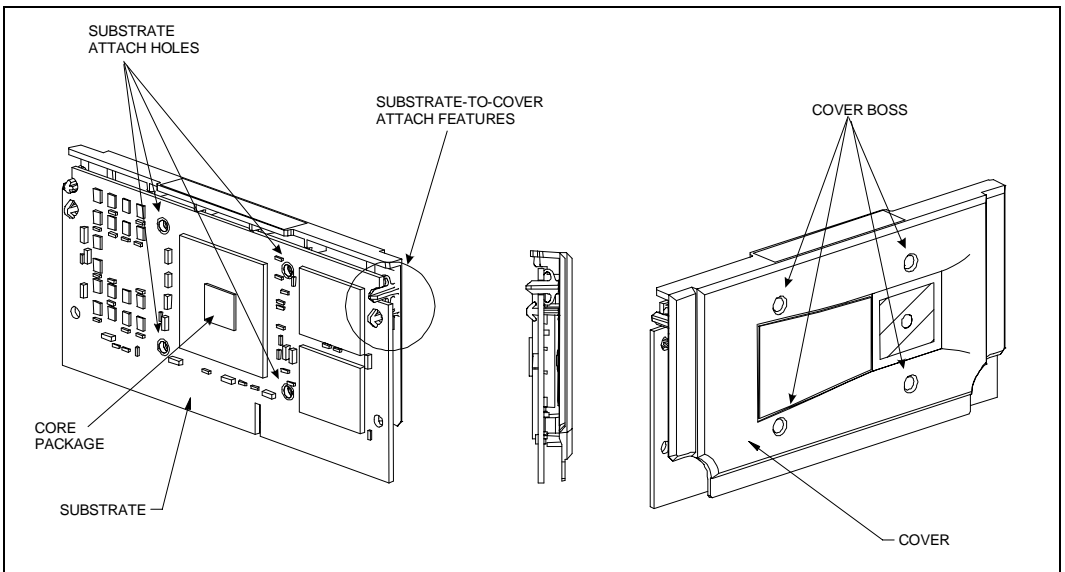

Figure 2. S.E.C.C.2 Package — Substrate and Cover Side Views (OLGA Processor Package Core Shown)

Additional terms referred to in this and other related documentation are the Mechanical Support Components (MSCs), which are used on the system to connect the processor to the system baseboard, and retention of the processor during system shock and vibration. The MSCs represent two possible solutions for retention of the processor in the SC242 connector. This application note will focus on the use of these components:

- **SC242 Connector** — The 242-contact slot connector (previously referred to as Slot 1) that the processor plugs into, just as the Pentium® Pro processor uses Socket 8.
- **Retention Mechanism Attach Mount** — Mechanical piece, which secures a threaded fastener type retention mechanism to the baseboard.
- **Retention Mechanism (RM)** — Mechanical components, which hold the processor and heat sink assembly in the SC242 connector.
- **Universal Retention Mechanism (URM)** — One RM design which holds processors in packaged in S.E.C.C., S.E.C.C.2 or S.E.P.P package styles
- **SEPP Retention Mechanism** — One RM design which holds processors packaged in either S.E.C.C.2 or S.E.P.P packages. This version has a slightly lower profile than the URM.

- **Heat Sink Retention Clip** — Plastic clip design to apply steady loads to the thermal interface material and retain the heat sink.
- **Substrate Attach Holes** — Clearance holes in the substrate to allow the heat sink retention clip to clear the substrate.
- **Cover Boss** — Feature formed in cover to retain the heat sink retention clip.

2.2. S.E.C.C.2 Package Design and Construction

2.2.1. S.E.C.C.2 PACKAGE ASSEMBLY

Figure 3 shows an exploded view of the S.E.C.C.2 package with the processor core, substrate, and cover shown.

The design of the S.E.C.C.2. package and materials used in the package undergo testing to assure the highest quality. Testing is performed across multiple lots and the correlation of lot data to manufacturing performance at Intel is determined. Suppliers also undergo quality audits in order to demonstrate manufacturability and quality-to-performance specifications.

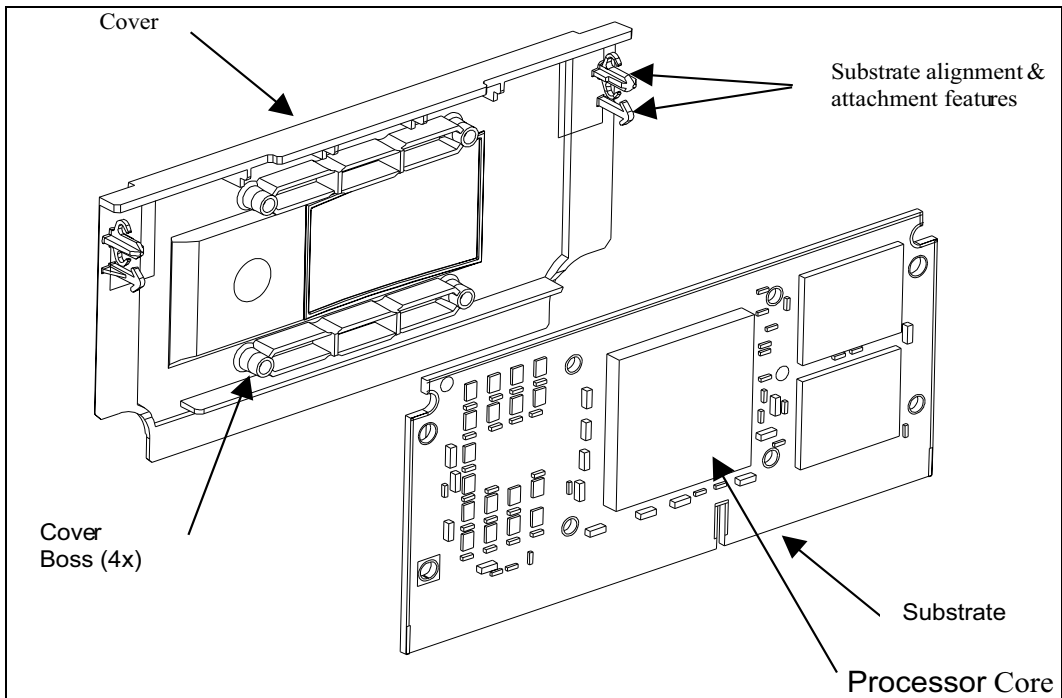

Figure 3. Exploded View of S.E.C.C.2 Package

2.2.2. S.E.C.C.2 PACKAGE SUBSTRATE

The S.E.C.C.2 package contains a processor core and other components mounted onto a substrate. The substrate has contact fingers on one edge that provide the electro-mechanical connection to the SC242 connector (and thus to the system baseboard). The substrate is fabricated of FR-4 based organic laminate material and has a minimum flammability rating of 94V-0. Copper trace and power plane parametrics, along with other key performance and manufacturing designs, have been selected to provide optimum electrical performance. The

edge finger contacts are gold plated over a nickel barrier layer for a reliable substrate edge finger to SC242 connector electrical contact. The edge fingers are equally distributed between the primary and secondary sides of the substrate (121 edge finger contacts per side, 242 total contacts). A key slot is provided in the edge finger array, off center of the card length, to prevent improper placement of the S.E.C.C.2 package substrate into the SC242 connector. Please consult the applicable processor datasheet for detailed mechanical dimensions and signal listing for the substrate edge fingers.

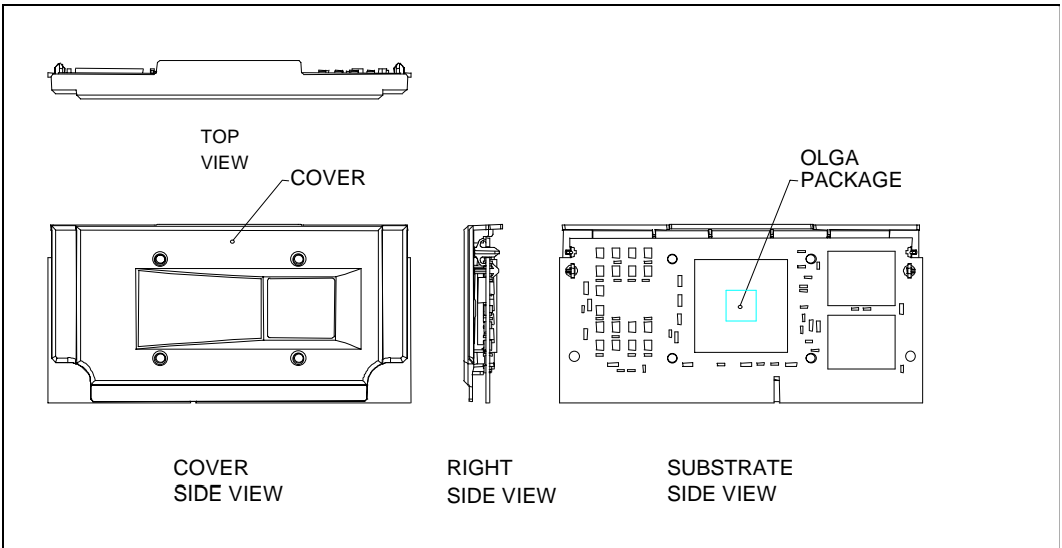

Figure 4. S.E.C.C.2 Package with OLGA Core and L2 Cache

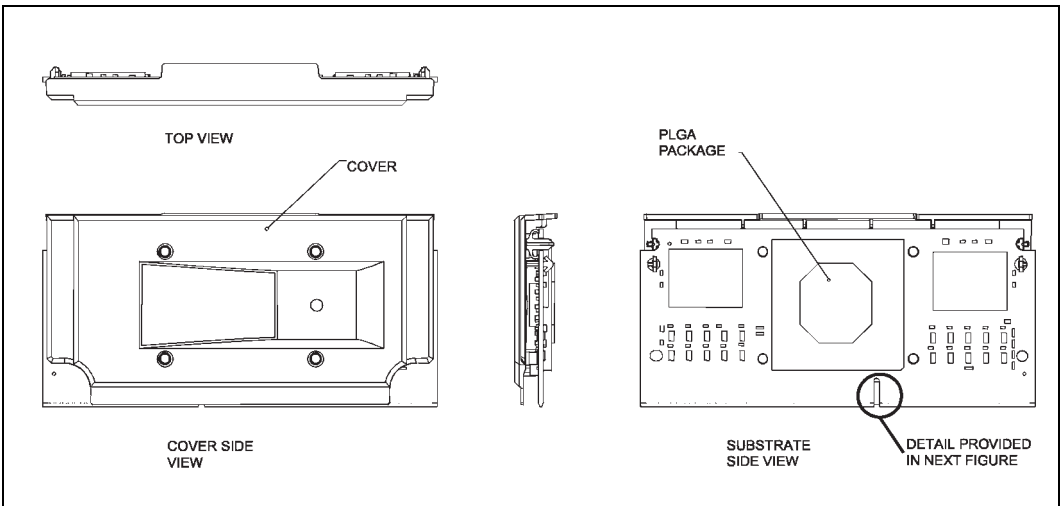

Figure 5. S.E.C.C.2 Package with PLGA Core and L2 Cache

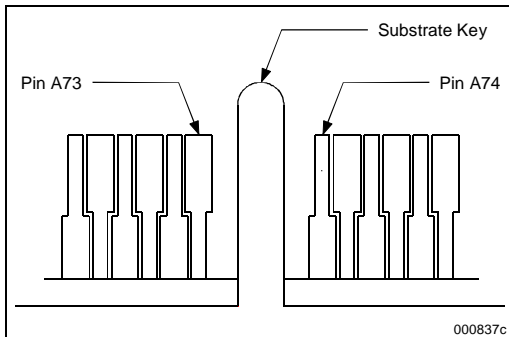

Figure 6. Substrate Edge Finger Contact and Key Detail

2.2.3. PROCESSOR CORE PACKAGE

The processor core for the S.E.C.C.2 package can be in one of two styles Plastic Land Grid Array (PLGA) Or Organic Land Grid Array (OLGA).

The OEM must make sure that heat sinks are designed to accommodate the different processor core package styles.

2.2.4. BSRAM

The BSRAMs in the S.E.C.C.2 package are packaged in commercially available QFP packages.

2.2.5. COVER

The S.E.C.C.2 cover is made of a molded high grade plastic. It is recommended that the S.E.C.C.2 package not be subjected to storage temperatures above 85 °C, based on the assembly materials maximum continuous use temperature. (See the datasheet for your specific processor for recommended storage and operational temperature maximums.)

2.3. Package Handling and Shipping Media

The S.E.C.C.2 package was designed to be a robust packaging solution for processors. Sealed, desiccant, ESD protective bags are not required, and thus not used, during shipping of the processors from Intel. The S.E.C.C.2 package processor, though, should be unpacked at ESD workstations. The package is **not**

meant to survive severe mishandling such as: dropping the processor from a workstation table top to the floor; foreign material contact on substrate edge fingers; and any attempt to disassemble the cartridge package.

This section will provide additional handling guidelines and information on the shipping media used for the processors. The processor datasheet contains the operational and storage specifications.

2.3.1. S.E.C.C.2 PACKAGE HANDLING PRECAUTIONS FOR ESD PROTECTION

Electrical fields are able to penetrate electrical devices. An ungrounded person handling a component or computer board in a nonstatic shielding container can cause a large charge to be transferred through the container into the sensitive electronic device.

Eliminating static electricity in the work place is accomplished by grounding operators, equipment (including the use of dissipative table mats) and parts (components and computer boards). Grounding prevents static charge buildup and electrostatic potential differences. Electrical field damage is averted by transporting products in special electrostatic shielding packages (i.e., antistatic or dissipative carriers).

Refer to Package Databook located at the Intel website for detailed information, guidelines and recommendations on proper precautions against component damage due to ESD. The Package Databook also contains information on package handling, electrical overstress and other information.

2.3.2. S.E.C.C.2 PACKAGE HANDLING PRECAUTIONS

In the S.E.C.C.2 package additional handling precautions should be observed prior to the heat sink installation.

- Handle the processor by the edges of the substrate, without touching the gold finger areas.
- Place the S.E.C.C.2 on surfaces with the cover side down.
- Avoid touching the OLGA processor package.
- Avoid situations where the substrate components can be hit and potentially be knocked off (capacitors/resistors).

Avoid S.E.C.C.2. package substrate deflections induced during handling and/or assembly. The S.E.C.C.2. package cannot exceed 0.050" deflection as measured

from the end of the substrate in the direction of the heat sink and 0.25" deflection as measured from the end of the substrate in the direction away from the heat sink.

2.3.3. PACKAGE ENABLING

Intel has provided reference designs for the support components. The support components include, Retention Mechanism, Heat sink, Thermal Interface Material, and Heat sink attach clip. The paragraphs below describe the handling of each of these components during integration.

2.3.4. RETENTION MECHANISM

The retention mechanism is used to guide the S.E.C.C.2 package and heat sink assembly into the SC242 connector and when fully seated, provides structural support. Insertion force of a S.E.C.C.2 package and heat sink assembly into a connector with a retention mechanism is 35 lbs. maximum. Extraction force in the same configuration is a maximum of 25 lbs.

System mounting of the retention mechanism is on the primary side of planar. Installation and removal of the retention mechanism utilizes common tools such as Phillips screwdriver, pliers, and Allen wrench. Caution must be taken not to damage the planar or S.E.C.C.2 package during retention mechanism installation or removal.

2.3.5. THERMAL INTERFACE MATERIAL

The thermal interface material is used to assure good heat transfer between the S.E.C.C.2 package and the heat sink. The heat sink supplier typically applies this material. A protective cover is placed over the thermal interface for shipment. Assure the cover is removed and no contaminants exist in the material prior to attachment to the S.E.C.C.2 package.

2.3.6. HEAT SINK AND HEAT SINK ATTACHMENT

The heat sink attachment mechanism must not induce permanent stress on the S.E.C.C.2 package substrate with the exception of a uniform load not to exceed 20 psi compressive loads to maintain the heat sink to processor thermal interface. There is 0.020" minimum clearance between the edge of the substrate hole and any trace in the substrate.

During heat sink attach, handle all components with clean gloves. It is recommended that the units be removed singly from the packaging as needed to attach

heat sinks. An operator should grip the substrate by the edges except for the connector edges — DO NOT TOUCH THE CONNECTOR EDGE. This could lead to contamination or scratch the edge connector fingers. During installation/removal of the heat sink/processor assembly into the retention mechanism, handle the assembly by the heat sink only.

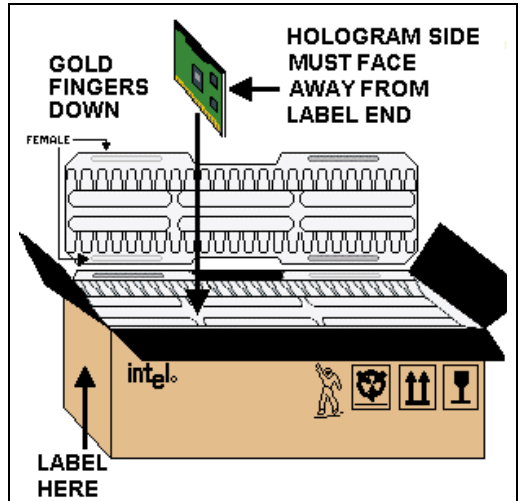

Figure 7. Pentium® II Processor Shipping Box

2.3.7. PENTIUM® II PROCESSOR SHIPPING MEDIA DESCRIPTION AND SPECIFICATIONS

The S.E.C.C.2 package Processor is packaged in a shipping box using materials which are different from PGA processors. The S.E.C.C.2 package processors are loaded into the thermo-formed ESD plastic with the substrate edge fingers down. As shown in Figure 7, the insert closes over the processor in a clam-shell fashion.

The processors are oriented such that the laser mark on the top edge of the S.E.C.C.2 package is visible when the top of the shipping box and insert are opened.

There are 25 S.E.C.C.2 packages per insert, and 2 inserts per shipping box for a total of 50 processors per shipping carton. The outer box is constructed from corrugated cardboard and has a conductive carbon coating inside to dissipate any electrostatic charge.

The insert in the shipping box is recyclable. Contact Intel for further information.

2.4. S.E.C.C.2 Package Quality and Reliability

The S.E.C.C.2 package components were submitted to a series of reliability stress evaluations. Table 1 lists the environmental test conditions, which were used in the study.

After each of the stress conditions described in Table 1, electrical end-point testing was performed to verify that the processor under test had not degraded. All processors under stress passed after every environmental stress test exposure.

2.5. S.E.C.C.2 Package Change Control

New products at Intel undergo development phases prior to production. Once the product has gone through the development phases and entered into production, it is still possible that changes may occur. A change is any modification that could impact performance, appearance, quality, reliability, functionality, interchangeability, cleanliness, handling, or manufacturability of the

supplied materials. This may apply to any change in the raw materials used directly or indirectly in the supplier's manufacturing process (including changing suppliers), any change in the manufacturing flow, or any change in handling or shipping materials used internally or in shipment to Intel.

In the event that a change is made to the S.E.C.C.2 package, Intel will qualify the changed material prior to approving the change for implementation. For any form, fit or function change, Intel will notify customers using the same criteria used for other Intel components.

2.6. S.E.C.C.2 Package Marking

In order to identify S.E.C.C.2 package (and processor) history, each unit is marked with the lot number and other information about the unit. This will enable traceability through the manufacturing process, factory planning and logistics, and shop floor control links to the actual units. Both human readable markings and an encoded 2-D matrix mark are provided. See Figure 8 and Table 2 for details on marking of the S.E.C.C.2 package.

Table 1. Environmental Test Conditions for S.E.C.C.2 Package

Test	Condition	Duration	Test Configuration
Temperature Cycling	40 °C to 85 °C	1000 cycles 15 min soak at each extreme	S.E.C.C.2 package
Random Vibration	5 Hz to 20 Hz 0.01 g ² /Hz sloping to 0.02 g ² /Hz (flat) 20 Hz – 500 Hz 0.02 g ² /Hz (flat) Area under PSD curve is 3.1 grms	10 min/axis	S.E.C.C.2 package, SC242 connector, and Retention Mechanism
Mechanical Shock	Trapezoidal 50G Velocity change of 170 in/sec	Three drops in each of six directions	S.E.C.C.2 package, SC242 connector, and Retention Mechanism
Biased Humidity	85%RH: 55C (3.3 V bias)	500 hours	S.E.C.C.2 package

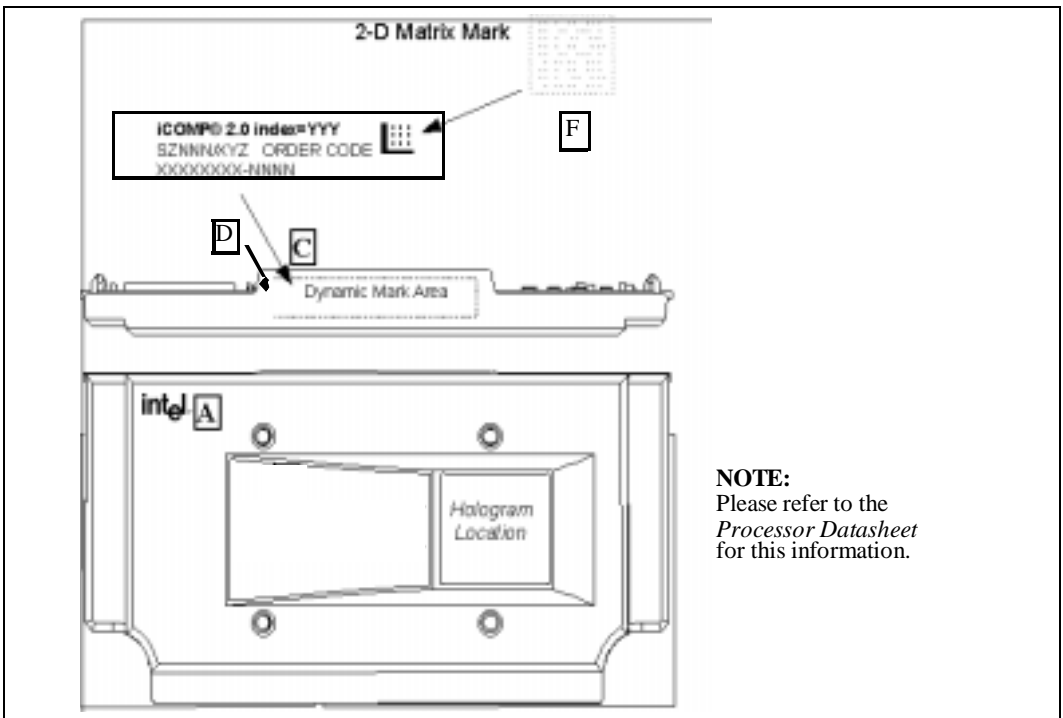

Figure 8. Processor Markings

Table 2. Description Table for Processor Markings

Code Letter	Description
A	Logo
C	Trademark
D	Logo
F	Dynamic Mark Area – with 2-D matrix

2.7. S.E.C.C.2 Package Processor Return Procedure

The processor should be returned directly to the local Quality Support Center via your components Customer Quality Engineer (CQE) contact. Within the U.S., the S.E.C.C.2 package can also be returned via the 1-800-628-8686 (Intel hotline). The following procedure is only applicable for returns needing

analysis. All other returns need to be handled through the normal RMA process. Heat sinks should **not** be removed. A description of the failure mode should be enclosed (contact your Intel CQE for a Failure Analysis/Correlation Request (FACR) checklist). S.E.C.C.2 package returns will follow the normal microprocessor FACR process and throughput commitments.

- Cartridge/heat sink should be returned in appropriate packing
 - Incorporate ESD Dissipative boxes/bags
 - Place unit into an ESD bag and wrap unit with at least two to four inches of wrapping. For multiple returns, ensure that individual units are wrapped and cushioned with at least two to four inches of bubble wrap/foam between units and between unit and outer box.
 - Processor return packaging is available through a third-party vendor as listed in the

Pentium® II Processor Supplier's Guide, located at the Intel website.

- Return box contains the white cardboard small box and the foam insert
- If desired, a bigger box holding five small boxes is also available
- Return Box Dimensions
 - Five-pack master box
 - Small white box (#M427), 4" x 4" x 7"
 - Foam insert set, die cut center (1) approximately 5.16" x 2.3" inside diameter, pads (2) approximately 1" thick

3.0. S.E.C.C.2 PACKAGE MECHANICAL SUPPORT COMPONENTS

The S.E.C.C.2 package is an evolution of the S.E.C.C. package. The elimination of the thermal plate reduces the number of thermal interfaces between the processor and the heat sink. This allows the OEM to use a lighter and less costly heat sink.

The main difference between the S.E.C.C. package and the S.E.C.C.2 package is that the S.E.C.C.2 package does not have latches to engage the RM. Instead a special heat sink geometry that interfaces with the RM provides the mechanical latch.

To keep the SC242 connector simple, there are NO features to retain the S.E.C.C.2 package during significant, but realistic, environmental conditions. These conditions are encountered during normal

transport of baseboards (with processors installed) and systems in an OEM production line and eventual shipment to an end user.

Intel has designed two reference mechanical solutions meant to support the S.E.C.C.2 processor package and ensure retention of the processor into the SC242 connector. These specific solutions are referred to as the Mechanical Support Components (MSCs). These components represent only two possible solutions to ensure the processor remains in the SC242 connector. Other methods and mechanical solutions will NOT be covered by this document. This document will only provide details on the use and operation of the MSCs. While each OEM must perform actual validation to ensure the processor stays in the SC242 connector, Intel has shown, through shock and vibration test validation, that these components will provide adequate mechanical support of the processor, when used correctly.

The MSCs consist of the SC242 connector, retention mechanism (RM), heat sink assembly (HSA), heat sink retention clip, and retention mechanism attach mount (RMAM). The SC242 connector provides the electrical path between the processor and the other logic components on the baseboard. The RM holds the processor into the SC242 connector during mechanical shock and vibration. The RMAM attaches the RM to the baseboard. Figure 9 and Figure 10 provide illustrations of all MSCs and how they interact with the processor. Please note that example heat sinks are shown throughout Section 3.0., Section 4.0. and Section 5.0. Heat sinks and thermal solutions are the responsibility of the OEM manufacturer. Please refer to processor's thermal application note for further information on evaluating heat sink designs.

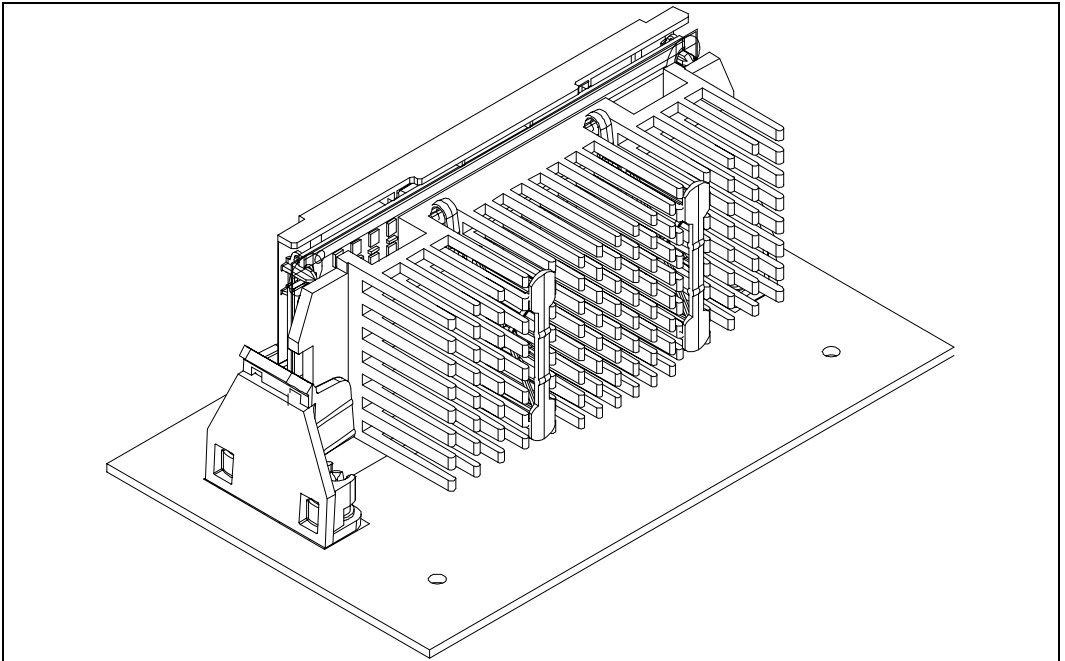
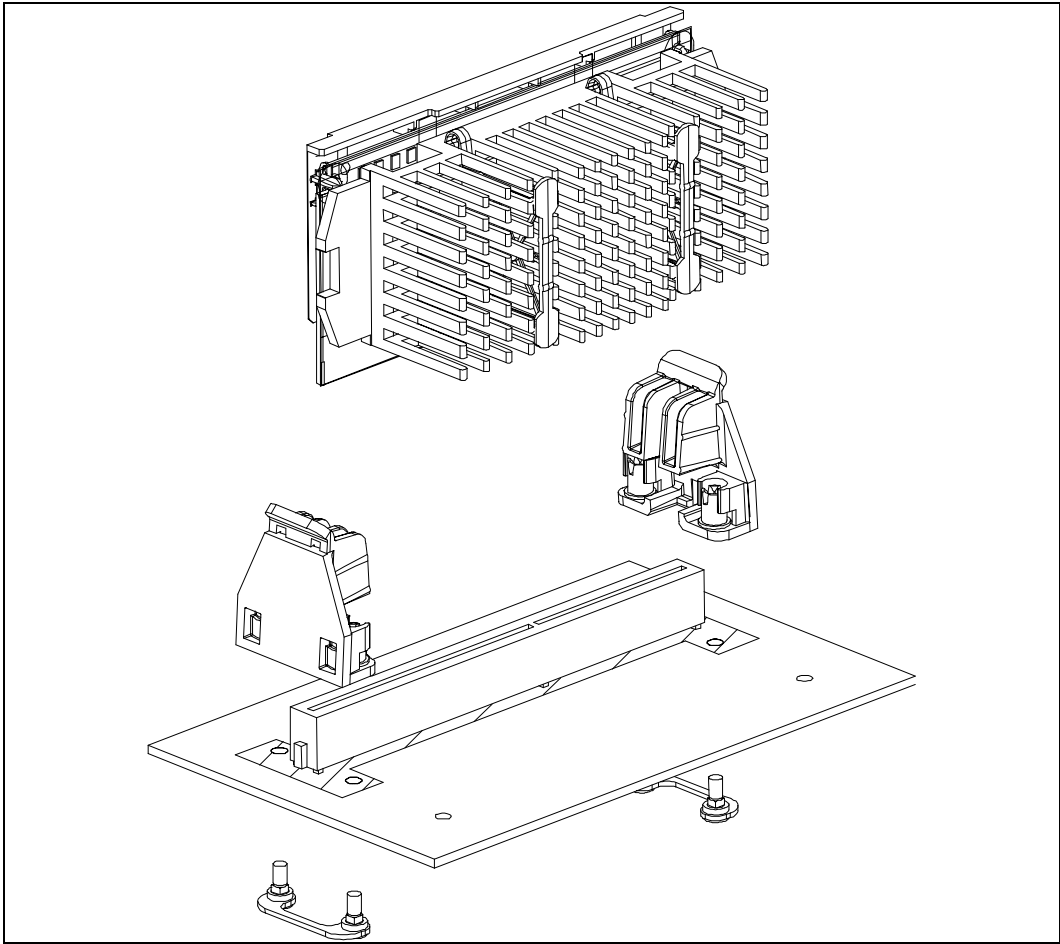

Figure 9. S.E.C.C.2 Package with All Mechanical Support Components, Full Assembly (SEPP RM Shown)



**Figure 10. Exploded View of S.E.C.C.2 Package with All Mechanical Support Components
(Example Heat Sink Attached to Processor)**

3.1. SC242 Connector

The SC242 connector is a 242 contact, 1.0 mm pitch, edge connector intended for the S.E.P.P., S.E.C.C. and S.E.C.C.2 packaged processors. The SC242 connector mounts on the baseboard and allows insertion and removal of the processor from the baseboard (see Figure 12). Mechanical, electrical and other technical details of the SC242 connector can be found by visiting the Intel developers website at: <http://developer.intel.com/design/processor/>

Figure 11 provides the basic baseboard footprint for the SC242 connector, RMAM, and RM components. Mechanical dimensions and other structural information for the MSCs are located in the SC242 Connector Design Guidelines and Mechanical Support Pieces for S.E.C.C. package Processors, both located at the Intel website. Intel does not supply the MSCs or equipment described in this application note. Refer to the updated Pentium® II processor Support Component supplier list located at the Intel website for supplier information.

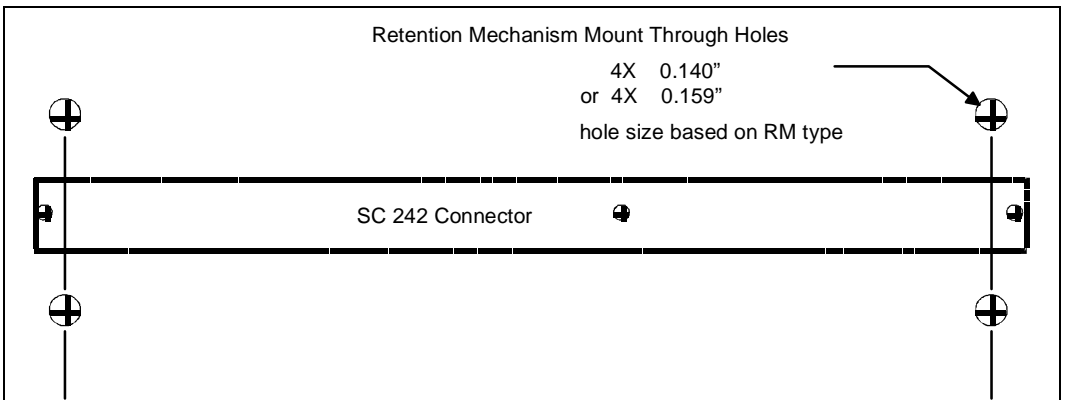

Figure 11. Baseboard Retention Mechanism, SC242 Connector Recommended Hole Locations and Sizes

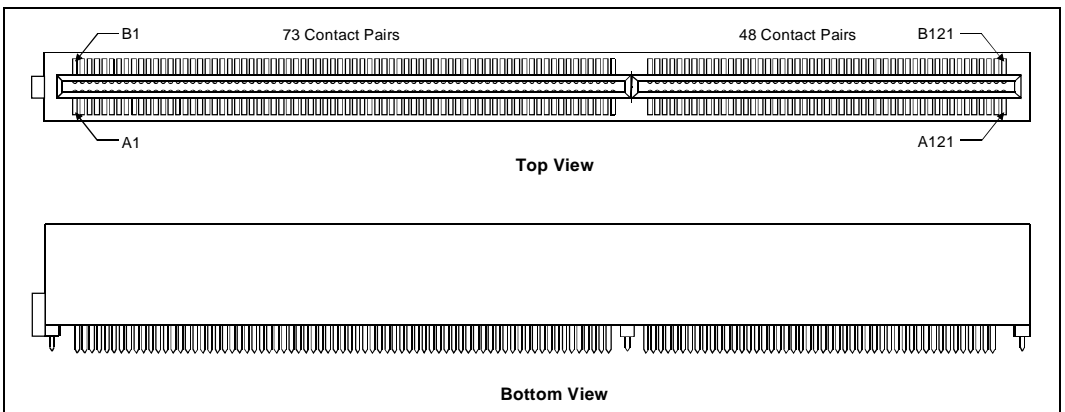

Figure 12. SC242 Connector

3.2. Retention Mechanism Attach Mount

The Retention Mechanism Attach Mount (RMAM) is a small assembly that is part of the Mechanical Support Components (MSC) (see Figure 13). The RMAM holds the retention mechanism to the baseboard using the captured nuts on the retention mechanism. The RMAM assembly (two studs and bridge) requires approximately

44 lbs-f to insert into the baseboard (using the defined holes shown in Figure 11). The RMAM studs are threaded and are fabricated from brass, and the bridge is molded plastic. The RMAM is designed to be inserted from the bottom of the baseboard. See the Intel website for further mechanical details of the RMAM that are not presented here. Figure 14 provides details on RMAM and baseboard interaction, providing depths underneath the baseboard itself.

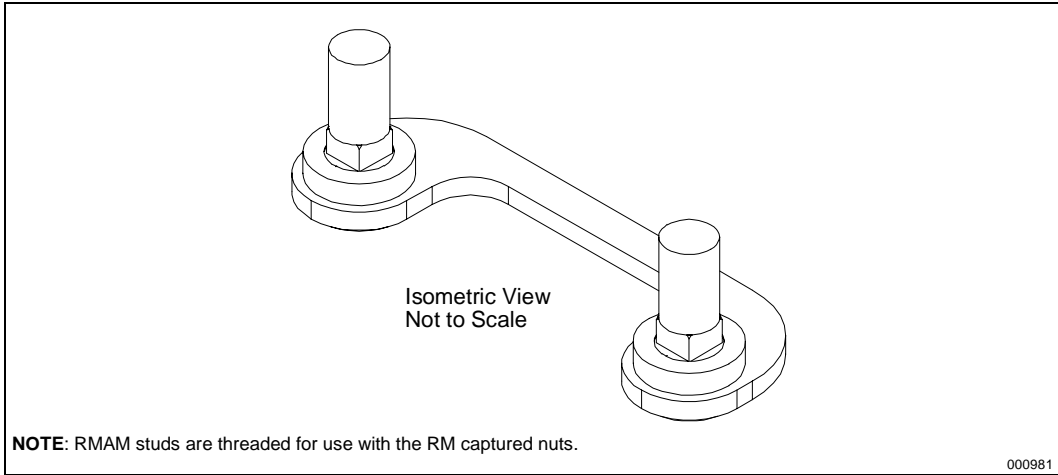

Figure 13. Retention Mechanism Attach Mount Assembly

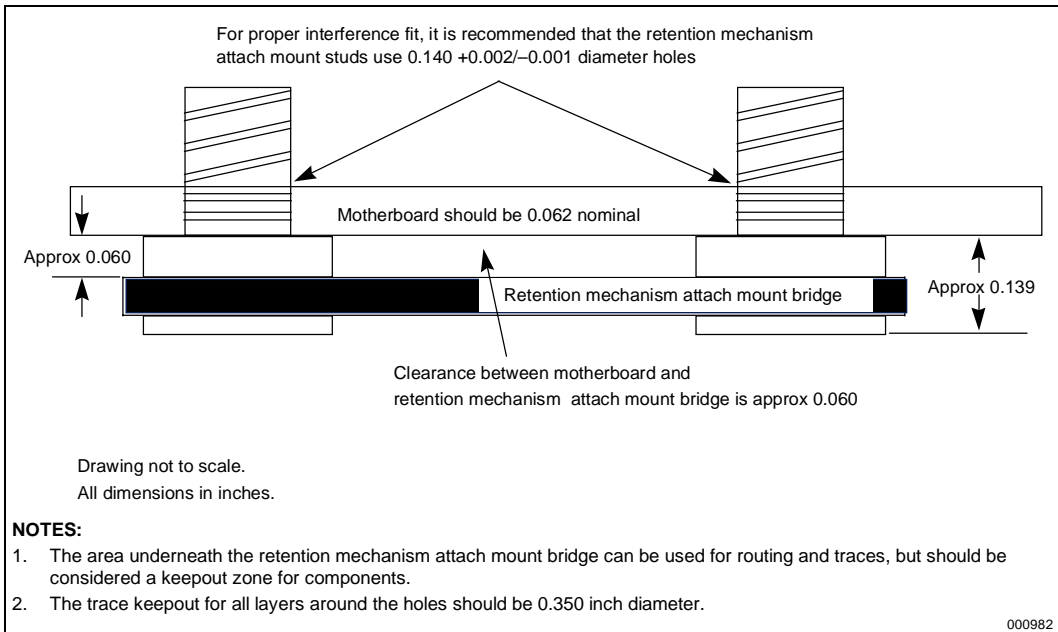

Figure 14. Retention Mechanism Attach Mount Baseboard Interaction Details

3.3. Heat Sink Retention Clip

3.3.1. HEAT SINK RETENTION CLIP

A new method for heat sink attachment has been designed. A formed plastic clip passes through clearance holes in the substrate and engages on bosses on the cover. Figure 15 shows the heat sink retention clip reference design. The heat sink retention clip provides clamping force to ensure good thermal grease bond line creation. The retention clip is fabricated from GE Ultem 1010, a polycarbonate plastic, in a near black color.

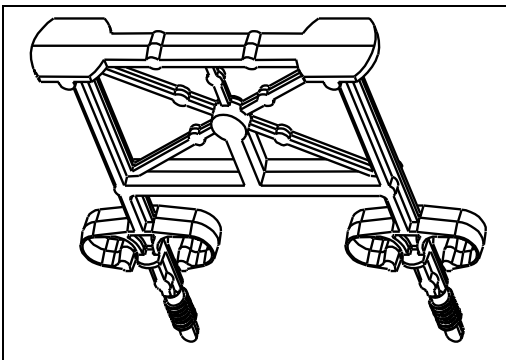

Figure 15. Reference Design for Heat Sink Retention Clip

3.3.2. S.E.C.C.2 PACKAGE HEAT SINK CLIP DESIGN CONSIDERATIONS

To ensure that heat sink clips designed for a processor in the S.E.C.C.2 package provide a robust heat sink attachment solution, the following recommendations and concerns should be considered:

- The clip should provide a sufficient compressive load between the heat sink and the processor core to complement the thermal interface material selected. For the reference design thermal interface the static clip load can not exceed 20 lb-f. The assembly transient compressive forces can not exceed a 100 lb-f normal uniform load or a maximum 75 lb-f nonuniform load. No line or corner loads are allowed.
- The thermal interface material must maintain a finite separation between the heat sink and the die

package during all dynamic and assembly loading and environmental tests. The purpose of this separation is to prevent heat sink to die package contact which testing has shown can result in die damage and processor failure. This is especially critical with OLGA core packages. The separation media must be capable of absorbing and/or dampening shock loads to be effective in preventing die damage. The reference design maintains a minimum of 0.001" separation between the die and the heat sink for a static loading of 12-20 lb-f over 0.25 in² surface

- Heat sink clips for the processor should be designed to stay within the allowed zones on the substrate. Factory, field service and end user installation and removal procedures should be considered. The clearances to the substrate are shown in the applicable processor datasheets.
- The heat sink clip should be designed to meet all the specifications listed in the data sheet for the specific processor you are using.
- Heat sink clips should be designed to meet system level shock and vibration requirements. Designs should be validated using shock and vibration testing.
- The thermal degradation characteristics of the heat sink clip material should be analyzed to determine if the expected temperature exposure will alter the retention force of the clip enough to affect the performance of the thermal interface.

The heat sink clip should be designed to provide adequate clamping force to ensure a robust interface between the heat sink, thermal plate and thermal interface material.

3.4. S.E.C.C.2 Heat Sink Mechanical Requirements

Figure 16 through Figure 18 provide an overview of the recommended design guidelines for heat sink designs compatible with the reference RMs. It is important to follow these guidelines to ensure the heat sink works properly with the RM and supports the processor. For the complete document see the Intel website for the Single Edge Contact Cartridge 2 (S.E.C.C.2) Heat Sink Attachment and Heat Sink Functional Requirements.

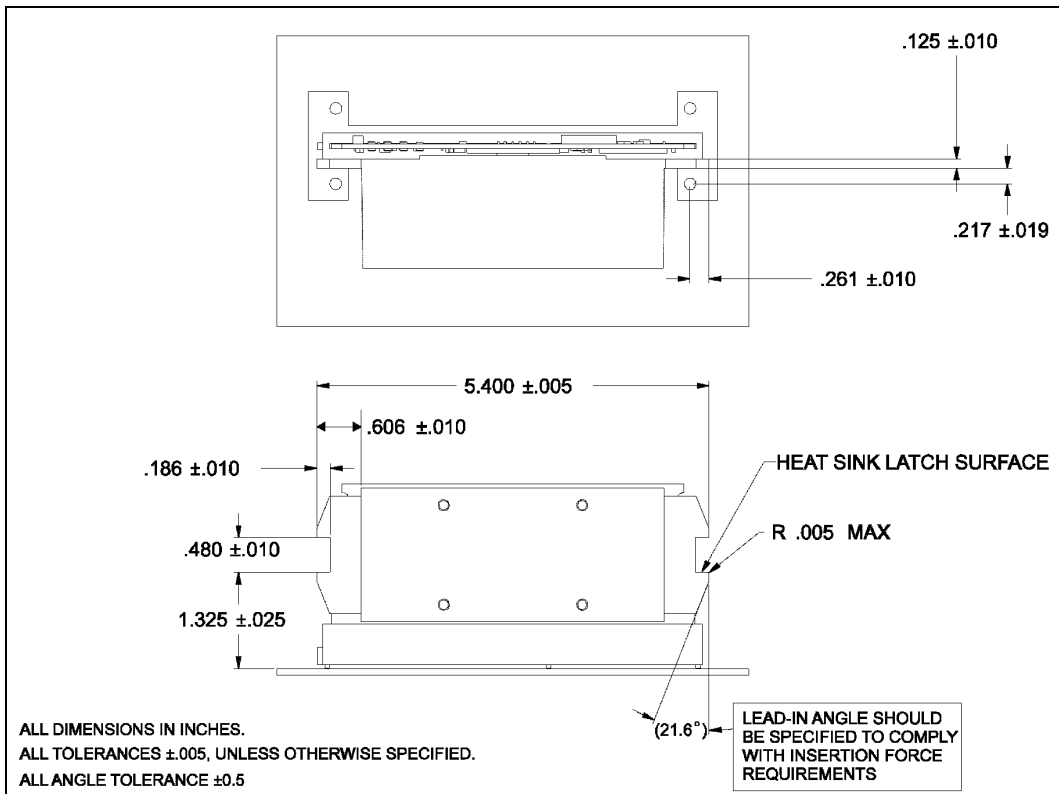
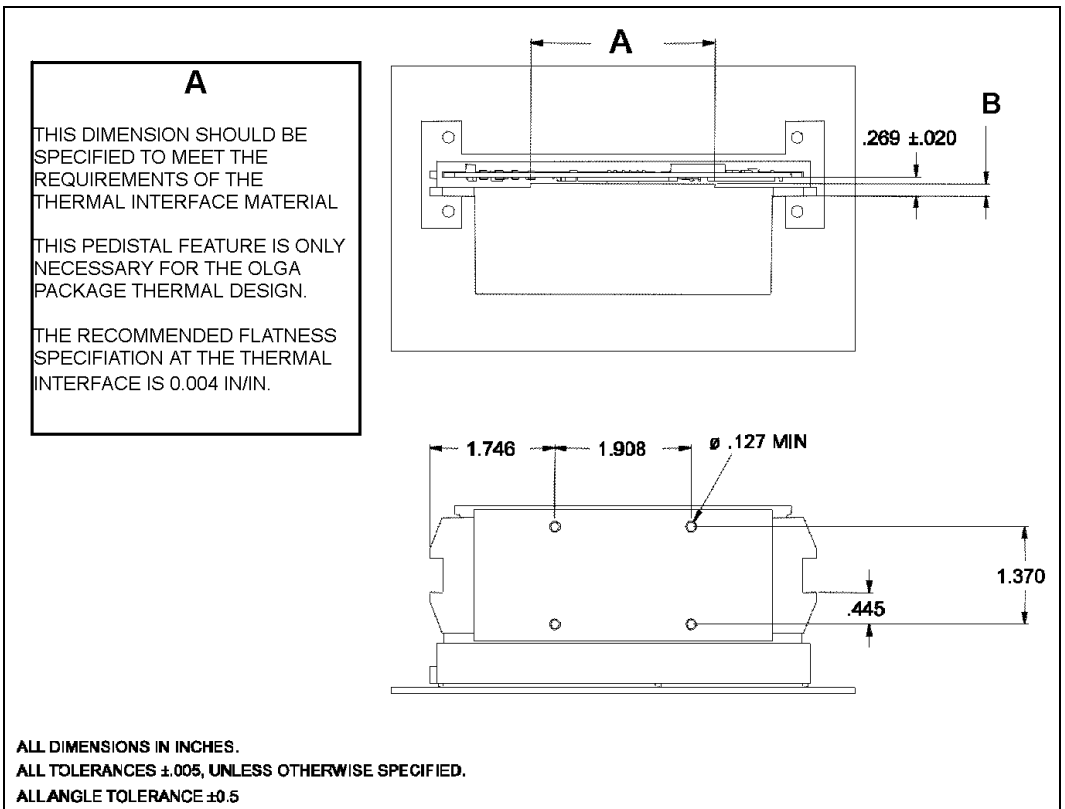

Figure 16. Retention Mechanism Features to interface Heat Sink

Figure 16 shows dimensioned critical features of the generic heat sink that will interface with the RM. The .480" wide rectangular cutout is designed to be the latching feature for the reference RMs and must be

located 1.325" above the planar. All other necessary dimensions are given to locate the heat sink latch surface.



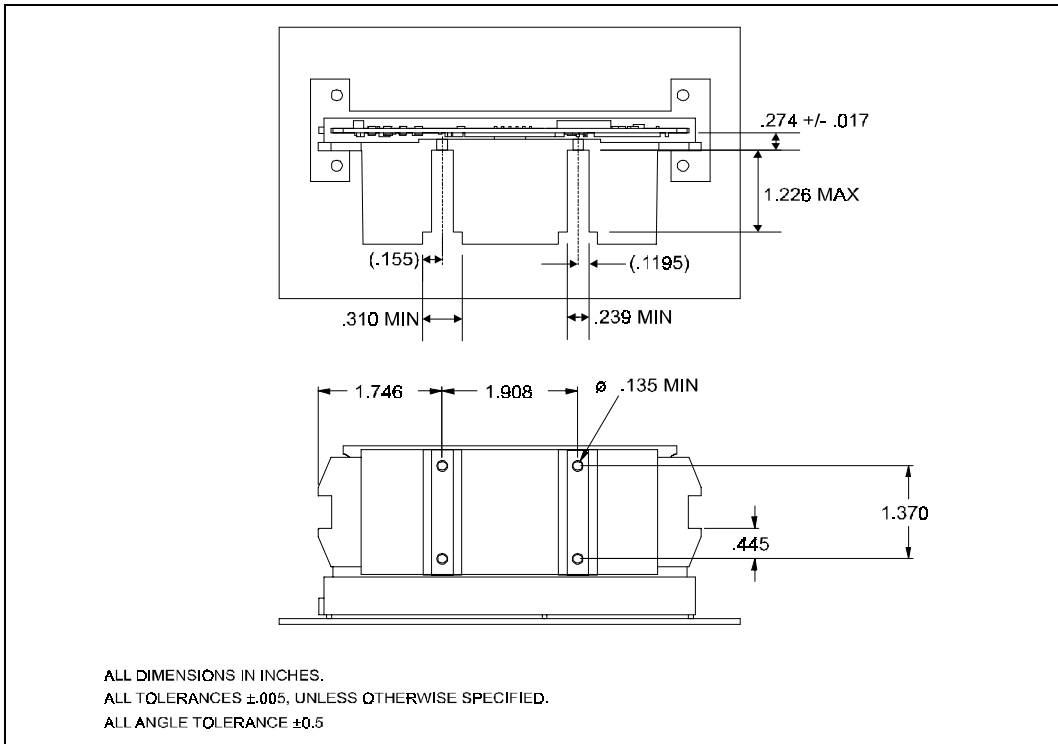

Figure 18. Heat Sink Requirements for Use with Reference Design Retention Clip

Figure 18 shows additional heat sink keep-out zones that are necessary in order for the design to be compatible with the reference heat sink attachment clip. Note that the dimension in the upper right of the figure is from the heat sink surface shown to the surface of the substrate and can be used for both PLGA and OLGA processor core packages.

3.5. Retention Mechanism Mechanical Description

The retention mechanism (RM) holds the S.E.C.C.2 package in the SC242 connector during mechanical shock and vibration. The reference design RM is symmetrical; and can be used on either end of the SC242 connector. The RM, is designed to engage with a slot on the heat sink. The RM comes in two styles described in the next two sections. The Plastic Fastener RM uses push pin plastic fasteners which uses a push/pry

assembly/disassembly process. The Captive Fastener RM utilizes the Retention Mechanism Attach Mount (RMAM) and a Phillips screwdriver assembly and disassembly process.

Correct orientation of the S.E.C.C.2 package is achieved when the ‘substrate key’ and the SC242 connector are engaged—the S.E.C.C.2. package will not seat into the SC242 connector without correct orientation. The RM also aids in processor alignment to the SC242 connector during insertion of the processor. Unlike the S.E.C.C., the S.E.C.C.2. package utilizes special features in the heat sink to latch into the RM. Instead of the leaf springs designed into the cartridge of the S.E.C.C., the S.E.C.C.2. package utilizes the existing spring-like properties of the retention mechanism to hold the S.E.C.C.2. package in the SC242 connector. The RM contains draft angles, lead-ins and chamfers for smooth travel of the processor down the posts and into the connector (see Figure 19 and Figure 20).

The RM is comprised of two pieces: RM body, and captive or plastic fastener (see Figure 19). The RM body is the plastic housing which supports the processor. The captured nut screws onto the RMAM for a secure fit onto a baseboard. The plastic fasteners snap into clearance holes in the motherboard. For more detail on the support pieces see the Intel website for the Mechanical Support Pieces for S.E.C.C.2.

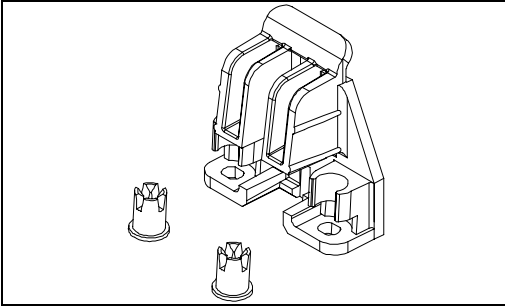

**Figure 19. SEPP Retention Mechanism, Exploded View
(Captive Fasteners Shown)**

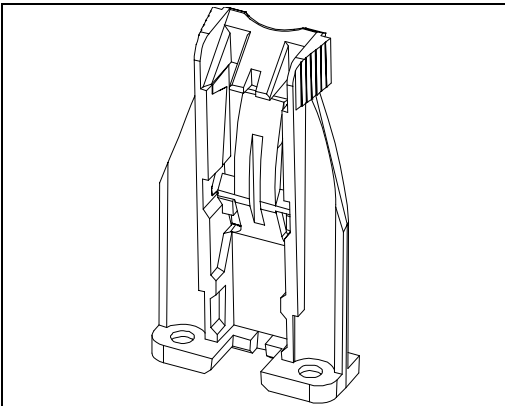

**Figure 20. Universal Retention Mechanism
(Without Fasteners)**

4.0. BASEBOARD INTEGRATION MANUFACTURING GUIDELINES

The S.E.C.C.2 package processor and mechanical support components (MSC) have similar manufacturing concerns and issues to those identified for the S.E.C.C. package. It is important to understand the impact to manufacturing for each of these components. All components are recommended for a robust solution for the S.E.C.C.2 package processor.

This section will address issues surrounding baseboard manufacturing and preparation. Section 5.0. will address issues surrounding system integration.

For the most current listing of vendors of mechanical solutions visit the Intel website. The manufacturing steps required for S.E.C.C.2 package, are a subset of the ones OEMs have already implemented for the S.E.C.C. package. The assembly requires a SC242 connector, retention mechanism and may include the retention mechanism attach mount. The heat sink for the S.E.C.C.2 package might be attached using the reference clip, which is different from the attachment solution for the S.E.C.C. package and systems manufacturing should carefully evaluate the integration of the processor and mechanical support components into the manufacturing environment.

4.1. Introduction and Suggested Integration Flow

Table 3 and Figure 21 provide the overall list of materials and suggested manufacturing flow for the integration of the S.E.C.C.2 package processor (and MSC), into the baseboard and system manufacturing flow. Baseboard related items highlighted in each will be covered in this section. The other materials and manufacturing steps will be covered in Section 5.0.

Table 3. S.E.C.C.2 Package Reference Mechanical Solution and Materials List

Assembly Type	Quantity per Board and System
Board Assembly	
SC242 connector	1
Retention Mechanism Attach Mount (if using RM with captive fasteners)	2
System Assembly	
Heat sink	1
Thermal Interface (usually part of heat sink assembly)	1
Heat sink Retention Clip	2
Retention Mechanism	2

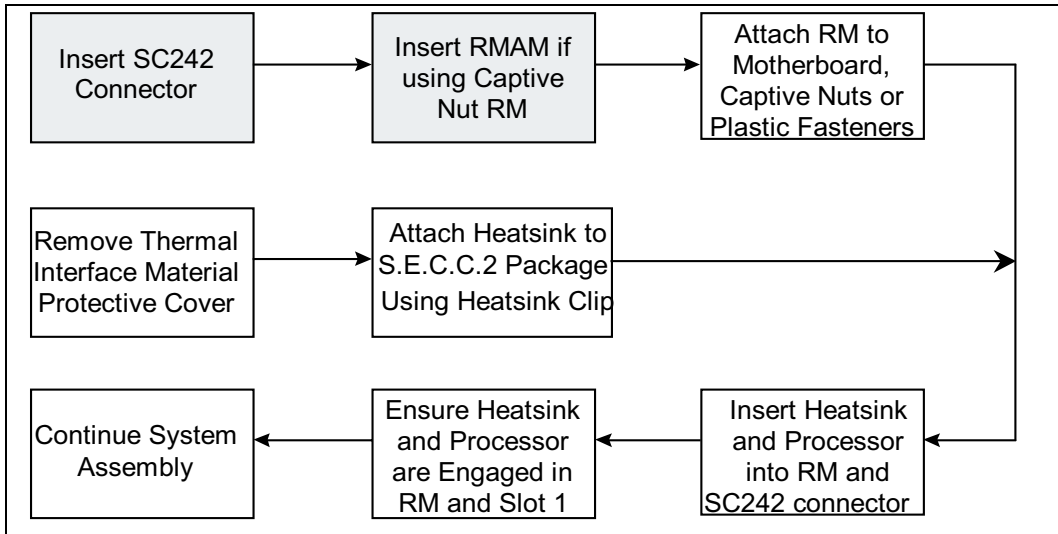

Figure 21. Suggested Baseboard/System Integration Manufacturing Flow (Bolded Boxes Covered in This Section)

As shown in Figure 21, it is recommended to perform SC242 connector installation, and RMAM mounting during the baseboard manufacturing process. The SC242 connector mounts similar to other edge connectors (PCI, ISA, AGP), but has specific requirements to ensure correct integration with the other MSC. The RMAM is a bottom side integration piece; a specific press is available for high volume manufacturing environments. See Section 5.3.5. for other information on installation issues.

4.1.1. RECOMMENDED SC242 CONNECTOR INSERTION STEPS AND REQUIREMENTS

NOTE

Only use SC242 connectors that are stored correctly in the supplier packaging. It is not recommended to use components that are loose or stacked without completely inspecting the component leads for alignment.

1. Pick the SC242 connectors, one at a time, from the supplier packaging and ensure that no contact is made with the lead area of the component. Supplier packaging should be placed on the line so

the retention features do not rest on the packaging material.

2. Place the SC242 connectors on the board so that all the leads are within their corresponding plated through hole (using the retention features as a guide, see Figure 22) and allow it to rest on the retention feature before the application of any insertion force.
3. Ensure that the SC242 connector stands vertically, that is, does not tend to lean to one side or another and sit evenly on the board, (if this happens, remove the SC242 connector and inspect the lead alignment). Note: Depending on the vendor, the SC242 connector may not stand vertically and will have to be held in place by hand.
4. Apply uniform insertion force to 2 positions on the SC242 connector (1/3 and 2/3 along the length of the component, (see Figure 23). Ensure that the SC242 connector enters the board smoothly. An operator can listen for the sound of a lead bending on the substrate.

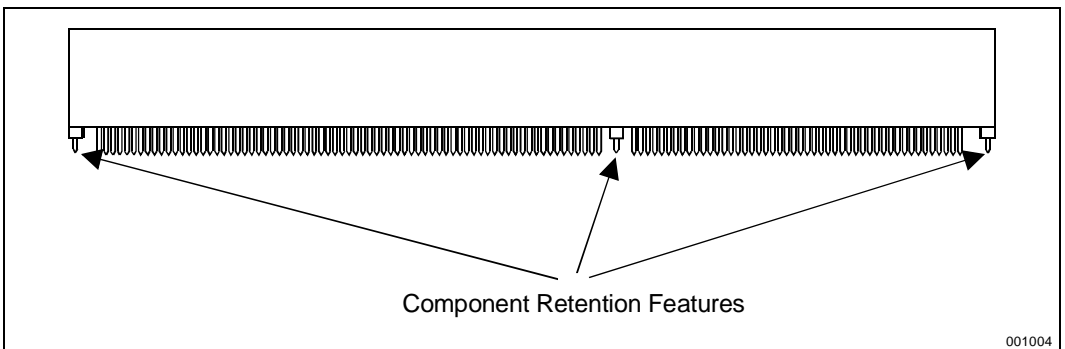

Figure 22. SC242 Connector, Retention Features Highlighted

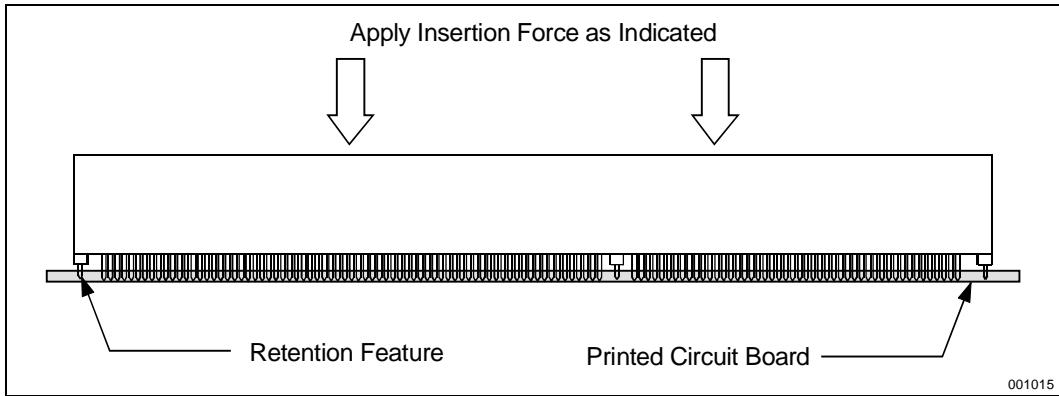
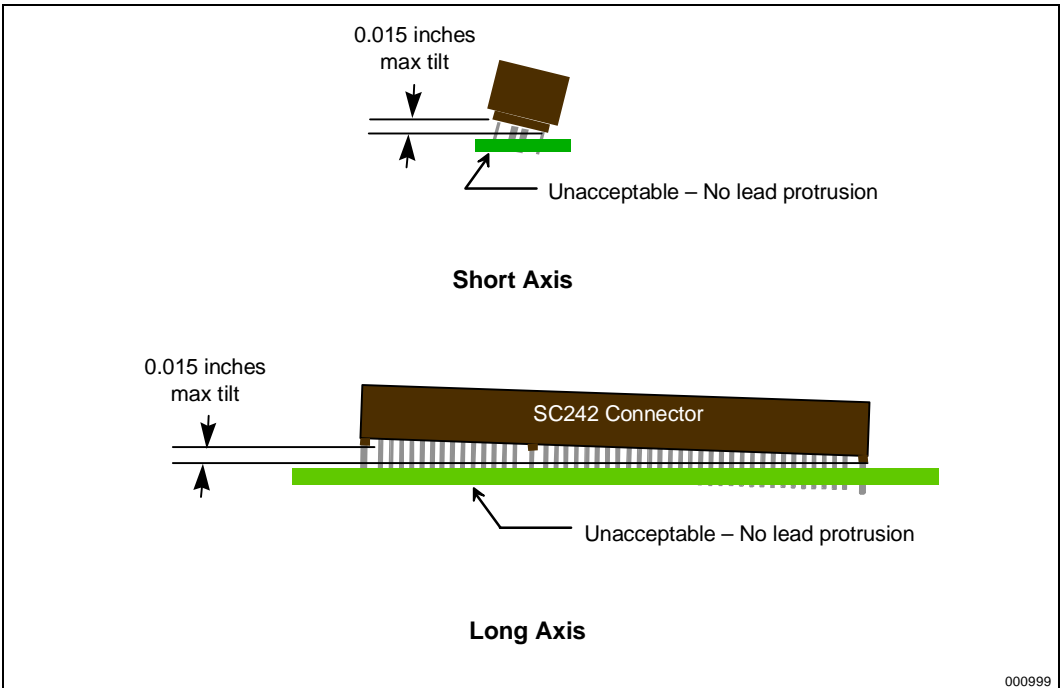

Figure 23. SC242 Connector Mounted in Baseboard

Figure 24 provides SC242 connector assembly guidelines that are recommended to be met to ensure the S.E.C.C.2 package interacts correctly with the remaining reference mechanical components. The recommended process capability along both axis is to ensure the S.E.C.C.2 package can interface correctly with the SC242 connector and other reference mechanical components (retention mechanism, etc.).

4.2. Retention Mechanism Attach Mount Installation

For the RMAM to work correctly, the attach mount stud must be fully inserted into the baseboard with a snug fit. The attach mount stud must be straight (normal or perpendicular) to the baseboard for purposes of attaching the Retention Mechanism. Figure 25 shows a baseboard with SC242 connector and RMAM installed.



000999

Figure 24. Recommended Process Capability to Ensure Correct Interaction of S.E.C.C.2 Package and Mechanical Support Components

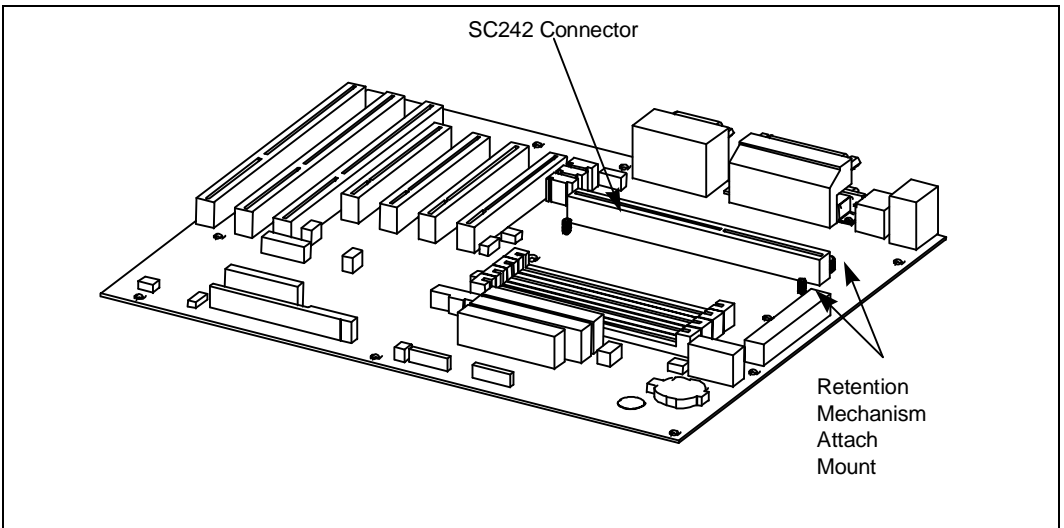

Figure 25. ATX Baseboard with SC242 Connector and RMAM Installed

4.2.1. ATTACH MOUNT ASSEMBLY CRITERIA

The RMAM studs should be protruding through the board on the top side as in Figure 26. The RMAM studs are designed to contact the baseboard hole in four locations in the hole, rather than around the entire circumference of the baseboard itself. There should be no cracking of the laminate around the holes through which the attach mount studs protrude. Cracks will typically be emanating radially from the hole edges. Cracks would occur due to an incorrect assembly that uses either too much force, incorrectly aligned studs, incorrectly sized holes in baseboard or incorrectly manufactured RMAM.

4.2.1.1. HVM Reference Procedures and Equipment for RMAM Installation

A set of machinery for efficient for efficient installation of the RMAM in High Volume Manufacturing (HVM) environments is available. The machinery is a press which performs the insertion of the RMAM into the baseboard, from the bottom side. The machine is

pneumatically driven, and requires baseboard specific jigs and fixtures to properly hold the baseboard and RMAM. The machine can also be used to rework (i.e., remove) an incorrectly processed RMAM. The Pentium II processor supplier list provides a list of suppliers for equipment for HVM presses, jigs and fixtures.

5.0. SYSTEM INTEGRATION MANUFACTURING GUIDELINES

5.1. Introduction and Suggested Integration Flow

Table 4 and Figure 27 provide the overall list of materials and manufacturing flow for the integration of the S.E.C.C.2 package processor and MSC into the baseboard and system manufacturing flow. System integration related items highlighted in each will be covered in this section. The other materials and manufacturing steps are covered in Section 4.0.

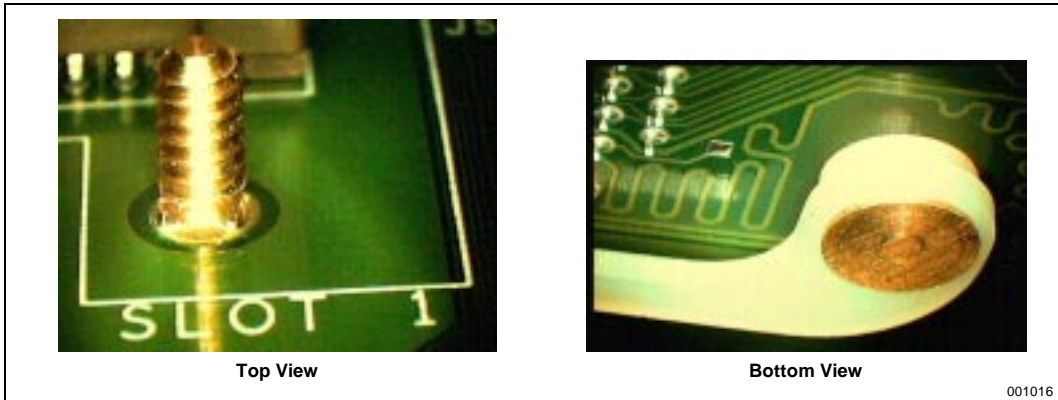

Figure 26. Attach Mount Installed in Baseboard

Table 4. S.E.C.C.2 Package Reference Mechanical Solution and Materials List

Assembly Type	Quantity per Board and System
Board Assembly	
SC242 connector	1
Retention Mechanism Attach Mount	2
System Assembly	
Heat sink (usually includes Thermal Interface)	1
Heat sink Retention Clip	2
Retention Mechanism	2

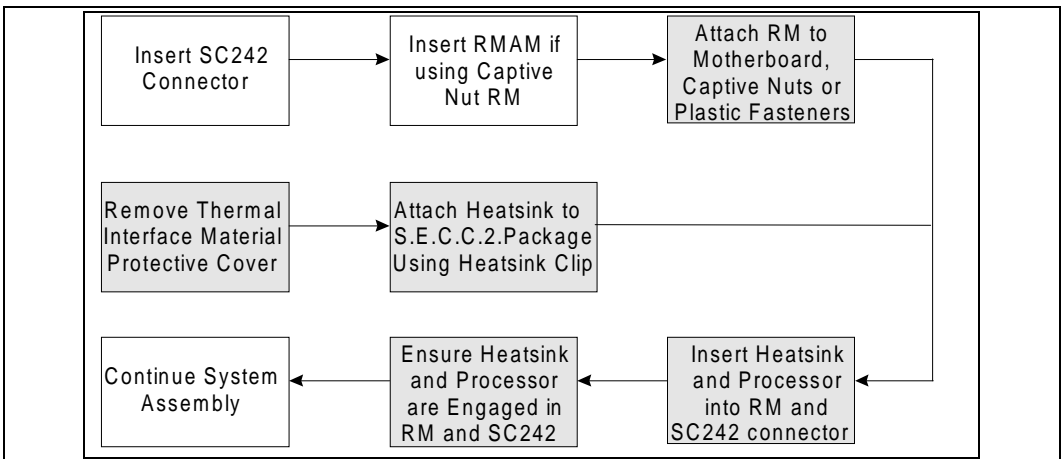

Figure 27. Suggested Baseboard/System Integration Manufacturing Flow (Bolded Boxes Covered in This Subsection)

5.2. Heat Sink Attachment to the Processor Core and S.E.C.C.2 Cover

A reference design for the thermal solution attachment is a heat sink retention clip. (Other attach solutions are possible, but have not been thoroughly investigated by Intel.) Thermal solutions must provide adequate thermal conduction paths to remove the heat generated by the processor and dissipate that heat into the system environment. The system environment must then ensure adequate overall circulation to properly cool the processor and other internal components. Each solution, though, requires good thermal interface material contact

and subsequent cooling performance. The applicable processor thermal design guidelines, provides detailed information on the thermal management and measurement processes. This section will describe attachment of the heat sink using the heat sink retention clip.

Assembly of the heat sink and heat sink retention clip to the cover must not induce excessive stresses to the substrate. Listed below are the key attributes to keep in mind when designing an attachment process. For the complete listing see the Intel website for the Single Edge Contact Cartridge 2 (S.E.C.C.2) Heat Sink Attachment and Heat Sink Functional Requirements.

5.2.1. HEAT SINK ATTACHMENT USING REFERENCE TOOLING

With the S.E.C.C.2 package, a new method for heat sink attachment has been designed. A formed plastic clip passes through clearance holes in the substrate and engages on bosses on the cover. The heat sink clip

provides clamping force to ensure good thermal bond line creation. The instructions below are an abridged version from AP-902, S.E.C.C.2 Heat Sink Installation and Removal Process. See the Intel website for the complete document the list of vendors producing this tool.

Maximum allowable substrate deflection	.025 in. away from primary side .050 in. toward primary side
Minimum required compressive force at heat sink/processor interface	12 lbf. min.
Maximum static compressive force at heat sink/processor interface	20 lbf. max.
Maximum transient compressive force at heat sink/processor interface	100 lbf. Max for uniform load 75 lbf. Max for nonuniform load

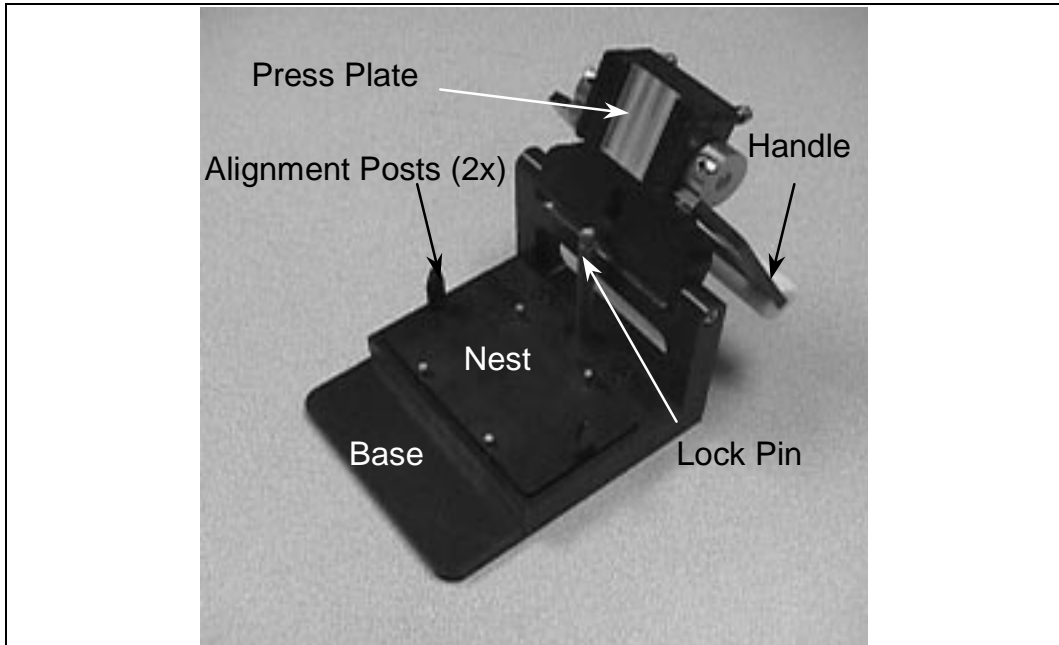

Figure 28. Heat Sink Attach Fixture, Open

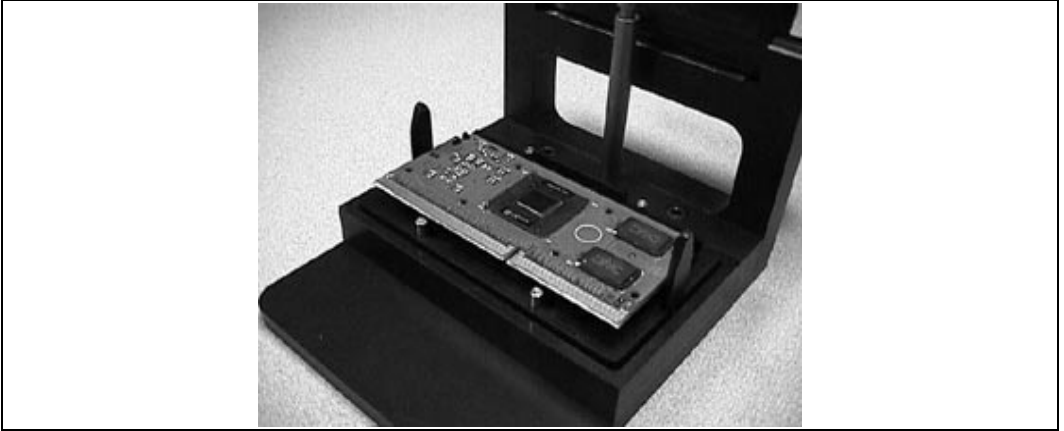

Figure 29. Position the Processor on the Tool

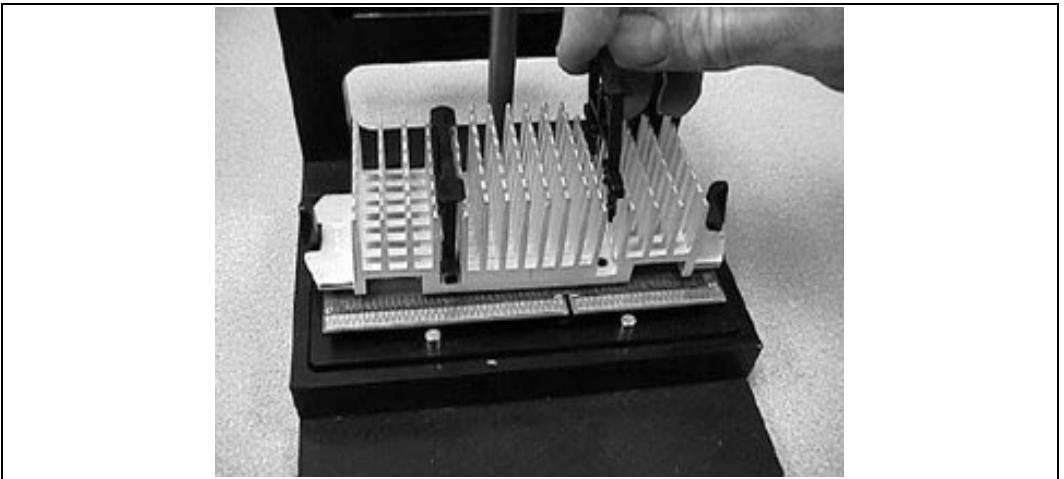

Figure 30. Heat Sink and Heat Sink Retention Clip Placement

1. Place the S.E.C.C.2 package in the nest between locating pins. The gold fingers face toward the operator with the cover flat on the nest.
2. Prepare heat sink for installation. Remove the backing from thermal interface material on the heat sink. Verify the thermal interface material on the heat sink is continuous; no through holes or debris in the material.
3. Place heat sink carefully on the processor core. Notches in heat sink tabs engage alignment posts on the fixture. Insert heat-sink retention clips through heat sink. The tips should just engage the cover bosses.

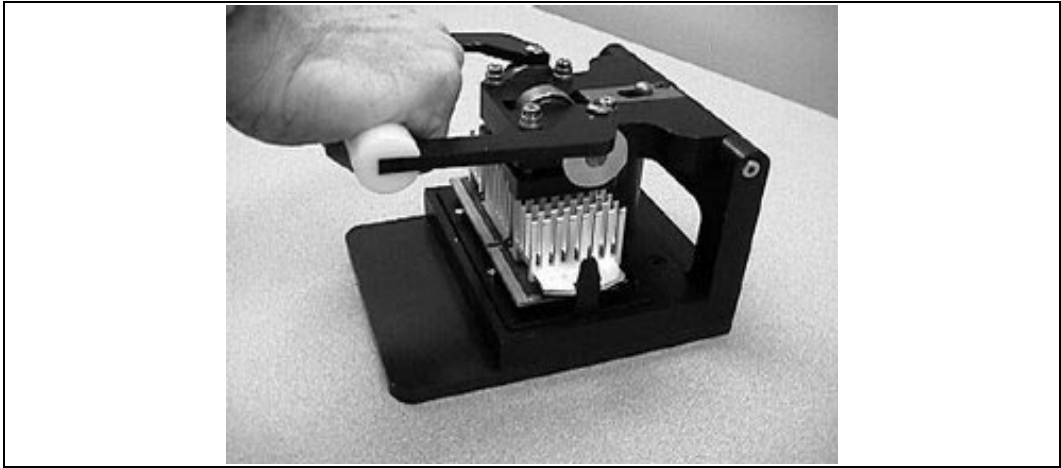

Figure 31. Pressing the Retention Clips into the Cover

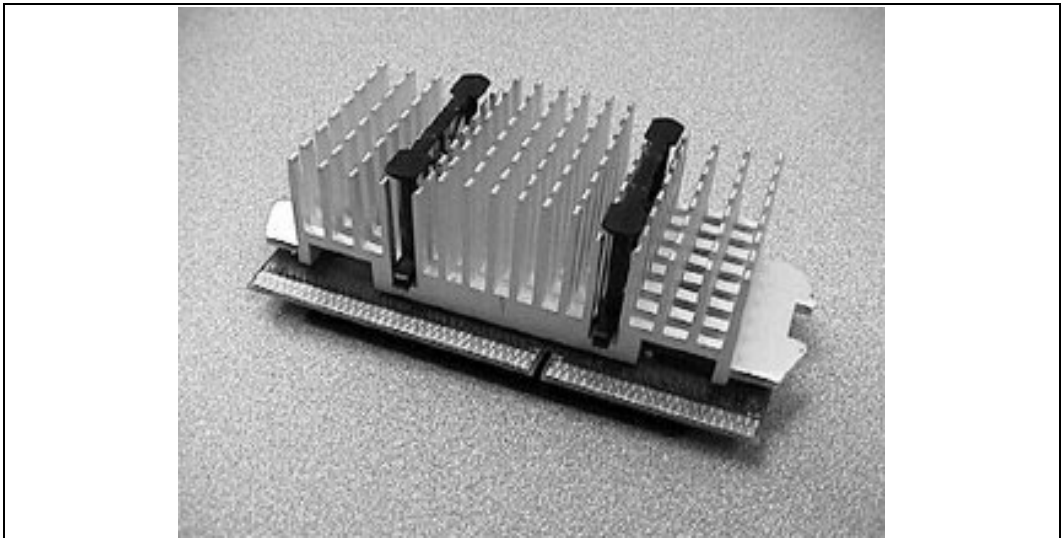

Figure 32. Assembled Processor and Heat Sink

4. Rotate the handle forward and down until it stops. The cover latch engages the lock pin to hold the top down. The cam rolls forward, applying pressure to the press plate. The press plate pushes the clips into the S.E.C.C.2 cover and seats the retention clip springs on the heat sink. The nest in the base will depress slightly as the retention clips are seated. This limits the load that can be applied by the tool to the processor core and the substrate.
5. Push the handle all the way back. Top rotates back just beyond vertical. Remove the processor and heat sink assembly from fixture.

5.3. Baseboard Preparation

5.3.1. MANUAL INSTALLATION OF THE CAPTIVE FASTENER RETENTION MECHANISMS

To install the captive fastener RM, orient the RM at either end of the SC242 connector. The part is symmetrical and fits easily around the end of the connector. Using a Phillips screwdriver rotate each of the four captive nuts in a clockwise direction while pushing down slightly to start the thread engagement (see Figure 33).

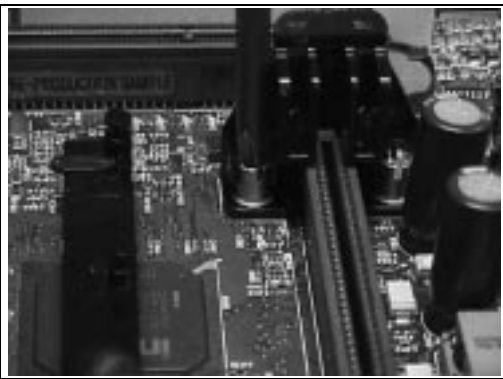

Figure 33. Installation of the Captive Fastener Retention Mechanism

5.3.2. MANUAL INSTALLATION OF THE PLASTIC FASTENER RETENTION MECHANISMS

Prepare the RM's by first inserting the plastic fastener assemblies into each of the four holes. Be sure that the white plastic pins are raised up from the black plastic component of the push-pin assembly, otherwise it may be difficult to insert the assembly into the motherboard hole. Next install the RM's onto the motherboard at both ends of the SC242 connector. Using the push-end of the insertion/removal tool apply a slight down ward force until the white plastic component of the push-pin is seated all the way down against the assembly (as shown in Figure 34). Repeat this process for all four of the pins.

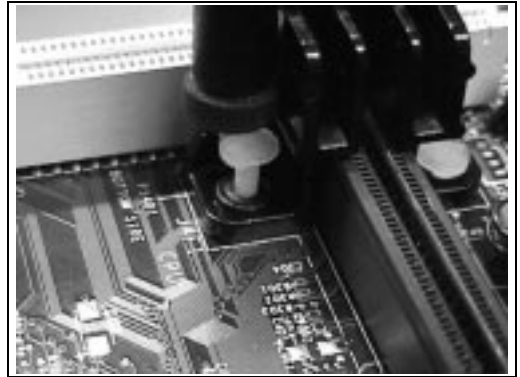

Figure 34. Installation of the Plastic Fastener Retention Mechanism

5.3.3. INSTALLATION OF THE PROCESSOR/HEAT SINK ASSEMBLY

Align the notch of the processor substrate with the notch on the SC242 connector. Insert processor/heat sink assembly into the guide rails along the retention mechanism making sure to install the heat sink into the retention mechanism and the processor substrate into the SC242 connector. Press firmly (but not with excessive force) on the top of the heat sink and cover until you hear a click as the retention mechanism pops back, firmly locking the processor into the SC242 connector.

The system integrator must ensure the baseboard is adequately supported during processor installation. An incorrectly supported baseboard might result in SC242 connector, trace or component damage during installation of the processor. The processor should be inserted enough to hear an audible click of the RM into the heat sink notch.

5.3.4. HVM REFERENCE PROCEDURES AND EQUIPMENT FOR THE REFERENCE RETENTION MECHANISM

A set of machinery for efficient installation of the RM in high volume manufacturing environment is available. The machinery is pneumatically powered, and consists of

four fixtured pneumatic screwdrivers together with baseboard-specific mounting jigs to properly hold the baseboard and RM. The machine tightens the captured nuts to the attach mount studs, while minimizing the potential for screwdriver damage to the processor and baseboard. The machine can also be used to rework (i.e., remove) an incorrectly processed RM. Refer to the Pentium II processor supplier list, for supplier information.

5.3.5. OTHER SYSTEM AND BASEBOARD ASSEMBLY ISSUES

For some chassis designs (e.g., ATX), the S.E.C.C.2 package may need to be inserted into the SC242 connector before the baseboard is assembled in to the chassis. Or the power supply unit (PSU) may need to be installed after the baseboard is placed into the chassis. It is important to ensure adequate distance is allowed between the S.E.C.C.2 package and the PSU during installation, removal and shock/vibration environmental testing. Also, the memory modules (e.g., SIMMs or DIMMs) may need to be inserted before the S.E.C.C.2 package. These types of issues should be addressed as the S.E.C.C.2 package processor is evaluated for introduction to the manufacturing flow.

5.4. Removal of Processor and Mechanical Support Components

Once installed, it is possible to disassemble the processor and mechanical support components. It is recommended to follow the correct procedure as outlined in this section. Improper use of force or effort can damage the processor, mechanical support components or baseboard. Pushing on the motherboard or components during processor removal can cause damage.

The first step is to remove the processor and heat sink assembly. The second and last step of disassembly is to remove the RM posts. How these posts are removed is determined by which type of post is used—captive fastener type or plastic fastener type.

5.4.1. REMOVING THE PROCESSOR

To remove the S.E.C.C.2 packaged processor grasp the processor and heat sink assembly by the heat sink. Apply pressure on the tab of one RM post, while pulling up on one end of the package and heat sink assembly. It is very important to only work on one end of the package and heat sink assembly. With sufficient force the RM post

should release the S.E.C.C.2. package. Once one end of the processor is free from the RM it will be possible to rotate that end up and out of the connector and RM.

The retention mechanism provides firm mechanical support for the processor. If you find that considerable force is required to remove the processor, consider wearing gloves to protect your hands and take care to keep your hands away from any metal edges on the chassis and processor package when removing the processor from the retention mechanisms. Loosening or removing one of the retention mechanisms greatly reduces the force required to remove the processor.

5.4.2. REMOVAL OF THE CAPTIVE FASTENER RETENTION MECHANISM

The captive fastener RM can be removed by unscrewing the fasteners from the RMAM studs. After unscrewing the fasteners, the RM can be lifted off of the studs and SC242 connector and placed aside.



Figure 35. Plastic Fastener Installation/Extraction Tool

5.4.3. REMOVAL OF THE PLASTIC FASTENER RETENTION MECHANISM

To increase the ease of disassembly, a tool has been developed to assist in the manual removal, as well as insertion, of the plastic pin fasteners. This tool is shown in Figure 35. Simply slide the forked head under the pin, pull up gently, and rotate the pin up as show in Figure 36 through Figure 38. Avoid touching the motherboard with the extraction tool so as not to damage any components or traces. Once the pins are raised, the RM can be

removed. The push pins and plastic fastener sleeve are not meant to be reused.

If no tool is available, removal of the motherboard from the chassis may be required. Once the motherboard is removed and while viewing the underside of the motherboard, use the tip of a ballpoint pen or other tool to carefully push the bottom of the white pin insert out of the black plastic fastener sleeve. Once the white insert pins are removed, carefully push the black sleeve portion of the fastener out of the motherboard to free the retention mechanism.

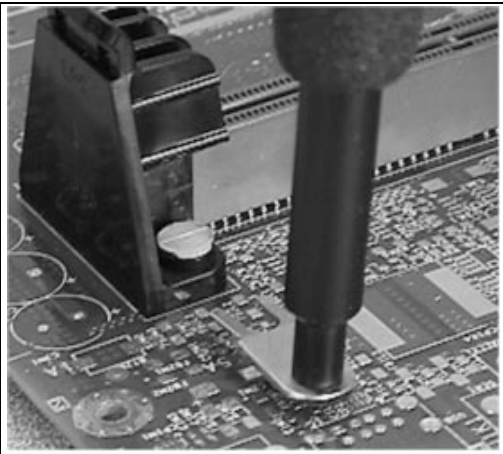

Figure 36. Position Installation/Extraction Tool

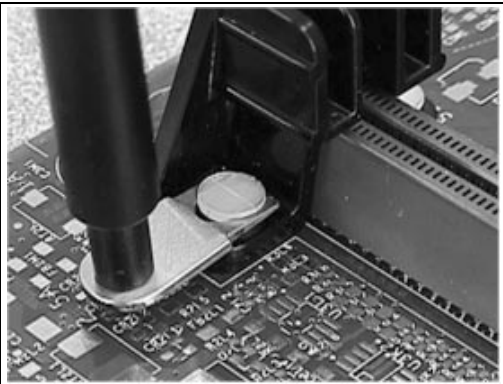

Figure 37. Pull Up Gently

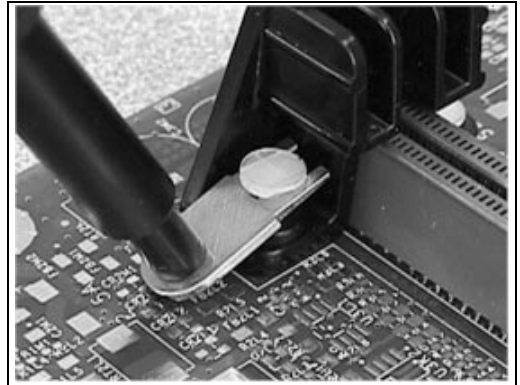

Figure 38. Rotate Up

5.5. Reuse of Processor and Mechanical Support Components

The processor and mechanical support components are robust components, meant for use in PC OEM manufacturing and system environments. The processor is “reusable” within the specification limits defined in the applicable datasheet. The mechanical support components can be removed from the baseboard as described above. Removal, though, is NOT recommended for the SC242 connector and RMAM. Each of these pieces interacts with the baseboard material and could damage the board if removed incorrectly. Also, if removed, each mechanical piece should receive a thorough inspection to ensure mechanical integrity.

6.0. INTEL BOXED PROCESSOR INTEGRATION GUIDELINES

Intel processors are also offered as a boxed processor. The term “boxed processor” refers to processors specifically designed and packaged for system integrators who use varied combinations of off-the-shelf chassis, power supplies, baseboard form factors, and peripherals to assemble personal computer systems. This provides for a wide variety of thermal environments in which the processor must operate within thermal specifications. For this reason, boxed processors include an active cooling solution (hereafter referred to as the fan heat sink) that is specially designed for the particular processor. Boxed processors also come with all the necessary hardware and installation instructions to integrate the boxed processor into a system.

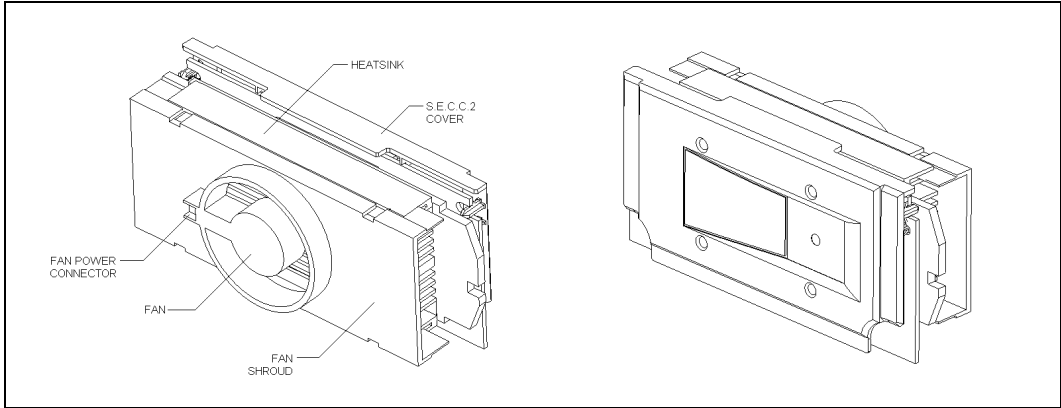

Figure 39 S.E.C.C.2 Package Boxed Processor

6.1. Boxed Processor Fan Heat Sink

Boxed processors are available in a variety of packages. For those boxed processors in the S.E.C.C.2 package the fan heat sink is already attached to the processor before the unit is shipped, using a thermal grease and heat sink retention clips. Specifications for the boxed processor's fan heat sink can be found in the applicable processor datasheet.

The fan heat sink comes in two pieces: a molded aluminum heat sink base and a plastic fan-shroud that attaches to the base. The shroud is made of a molded high grade plastic.

The fan heat sink requires clearance around the unit for proper airflow and cooling efficiency. The fan heat sink also requires the air-intake temperature to not exceed a specified limit, in order to keep the processor thermal plate below its maximum temperature. Clearance requirements and air-intake temperature requirements can be found in the applicable processor datasheet.

6.2. Boxed Processor Mechanical and Electrical Support Components

6.2.1. RETENTION MECHANISM

The boxed processor and fan heat sink are designed to be compatible with the RMs discussed in this document. The boxed processor does not ship with a RM. Motherboards designed for use by system integrators must include retention mechanisms that support the S.E.C.C.2 package.

6.2.2. FAN POWER CABLE

The fan heat sink also requires power to drive the integrated fan and provide needed airflow. A fan power cable is included with the boxed processor and connects to a power header on the baseboard. Specifications and location of the fan power header on the baseboard are defined in the applicable processor datasheet.

6.3. Boxed Processor System Integration Manufacturing Guidelines

Table 5 and Figure 40 provide the overall list of materials and manufacturing flow for the integration of the S.E.C.C.2 packaged boxed processor and support components into the system manufacturing flow. Baseboard Integration described in Section 4.0. is essentially the same.

6.3.1. PRE-INSTALLATION PREPARATION

1. Be sure that the motherboard kit includes a retention mechanism and instructions for installing it onto the baseboard.
2. Be sure that the boxed processor kit includes the following:
 - One processor with fan heat sink attached

- One power cable

3. Place the baseboard on an ESD workbench (not in a chassis). Be sure that the baseboard is bare (that is, no SIMMs, DIMMs, cables, or cards are installed) and that the holes for the fan heat sink support pegs are empty. If a passive heat sink support is installed on the baseboard, consult the manufacturer's documentation for instructions to remove it.

6.3.2. BASEBOARD PREPARATION – INSTALLATION OF THE RETENTION MECHANISM

Baseboards for system integrators should be shipped with a retention mechanism and include instructions on installing the retention mechanism, since such a design may be specific to that baseboard. In general, however, the procedure in Section 5.3 can be followed to install the retention mechanism in the baseboard.

Table 5. S.E.C.C.2 Boxed Processor System Assembly and Material List

Assembly Type	Quantity per System
System Assembly	
Processor with Attached Fan Heat sink	1
Retention Mechanism	2
Fan Power Cable	1

Note: Retention Mechanism is not included with the boxed processor and should be supplied to the system integrator by the motherboard vendor.

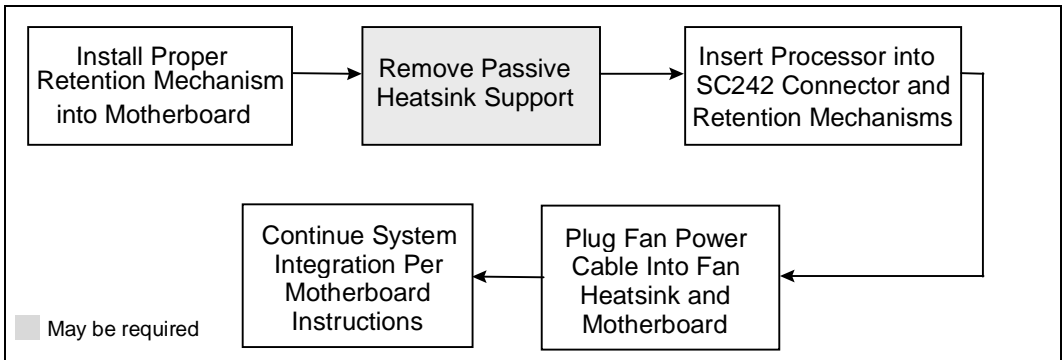

Figure 40. Suggested System Integration Manufacturing Flow

6.3.3. INSTALLING THE BOXED PROCESSOR

1. Align the notch of the processor substrate with the notch on the SC242 connector. Install the processor into the SCS242 connector by pressing firmly (but not with excessive force) on the top of the cover and the heat sink. Make sure to install the heat sink into the retention mechanism and the processors substrate in the SC242 connector.
2. Attach the small end of the power cable to the three-pin connector on the processor, and then attach the large end to the three-pin power header on the baseboard. Consult the baseboard documentation for the power header location.

6.3.4. REMOVING THE BOXED PROCESSOR

First, remove the baseboard from the chassis. To remove the boxed processor from the baseboard, follow these steps (the reverse of the installation process).

Disconnect the fan power cable from the baseboard.

Lift one end of the processor until it is freed from SC242. Lift the other end of the processor until it is freed from SC242. Lift the entire processor until it is free from the retention mechanism.