



## INTEL 380FB PCISSET: 82380AB MOBILE PCI-TO-ISA BRIDGE (MISA)

- PCI Bus at 25 MHz to 33 MHz
- ISA Bus at 7.5 MHz to 8.33 MHz
- 5 Volt ISA and PCI Interfaces
- Full ISA Support Including ISA Masters
- PC/PCI DMA Protocol for Software Transparent, Low Pin Count DMA on ISA
- Supports 3 ISA Slots
- 160-lead MQFP Package

---

The Intel 380FB PCISet (380FB) consists of the 82380FB Intel Docking Controller (MPC12) and the 82380AB Mobile PCI-to-ISA Bridge (MISA). The 380FB provides the logic necessary to build a full Hot Docking capable docking station with 5V PCI and ISA add-in expansion slots. MPC12 provides the docking control for Hot-Insertion, power management and a PCI-to-PCI bridge to a 5V PCI desktop style add-in bus. MISA provides a PCI-to-ISA bridge for a 5V ISA desktop style add-in bus.

MISA provides both a master and slave interface to the PCI bus. As a PCI master, MISA runs cycles on behalf of ISA masters. As a PCI slave, MISA accepts cycles initiated by PCI masters targeted for the MISA's internal configuration registers or ISA Bus.

MISA incorporates a fully ISA Bus compatible master and slave interface. MISA directly drives 3 ISA slots without external data or address buffering. The ISA interface also provides byte swap logic, I/O recovery support, wait-state generation, refresh and SYSCLK generation. MISA supports compatible ISA DMA timings for all 7 DMA channels. MISA integrates ISA refresh logic including refresh address generation and a refresh timer.

MISA implements the PC/PCI DMA protocol for the serialization of the docking station DMA and ISA master requests over the PCI Bus. MISA regenerates ISA DMA cycles from the PC/PCI DMA cycles taking place across the PCI Bus.

Information in this document is provided in connection with Intel products. No license, express or implied, by estoppel or otherwise, to any intellectual property rights is granted by this document or by the sale of Intel products. Except as provided in Intel's Terms and Conditions of Sale for such products, Intel assumes no liability whatsoever, and Intel disclaims any express or implied warranty, relating to sale and/or use of Intel products including liability or warranties relating to fitness for a particular purpose, merchantability, or infringement of any patent, copyright or other intellectual property right. Intel products are not intended for use in medical, life saving, or life sustaining applications. Intel retains the right to make changes to specifications and product descriptions at any time, without notice. The Intel 380FB PCISet may contain design defects or errors known as errata. Current characterized errata are available on request. Third-party brands and names are the property of their respective owners.

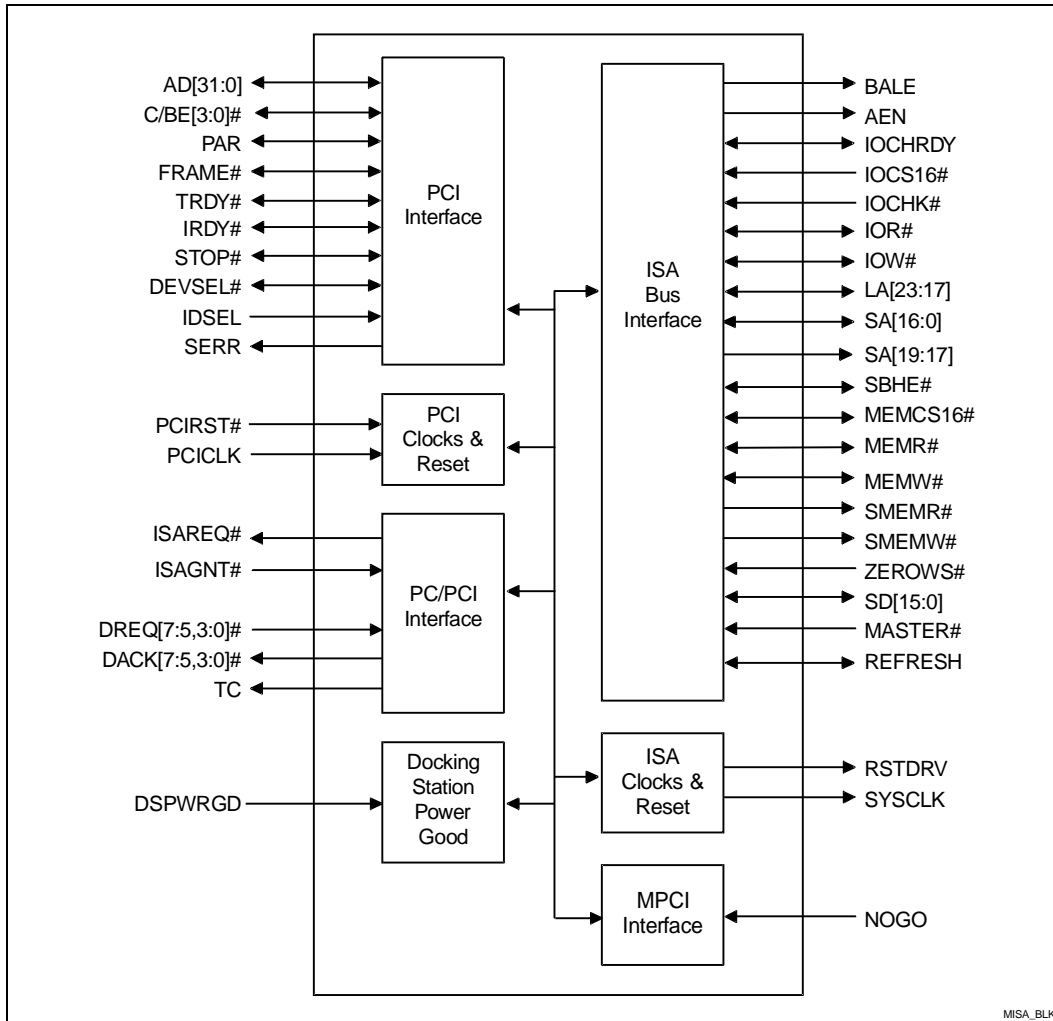

82380AB MISA Simplified Block Diagram



# CONTENTS

	PAGE
<b>1.0. ARCHITECTURE OVERVIEW .....</b>	<b>4</b>
<b>2.0. SIGNAL DESCRIPTION .....</b>	<b>5</b>
2.1. PCI Signals .....	5
2.2. PC/PCI Signals .....	6
2.3. ISA Interface Signals .....	6
2.4. MPC12 Signals .....	8
2.5. Test and Power Signals .....	8
<b>3.0. REGISTER DESCRIPTION .....</b>	<b>9</b>
3.1. PCI Configuration Registers .....	10
3.1.1. VID—Vendor Identification Register .....	10
3.1.2. DID—Device Identification Register .....	10
3.1.3. PCICMD—PCI Command Register .....	10
3.1.4. PCISTS—PCI Status Register .....	11
3.1.5. REVID—Revision Identification Register .....	12
3.1.6. CCODE—Class Code Register .....	12
3.1.7. HEADT—Header Type Register .....	12
3.1.8. IO_RCVR—IO Recovery Register .....	13
3.1.9. MISA_STS—MISA Error Status Register .....	14
<b>4.0. MISA BUS FUNCTIONAL DESCRIPTION .....</b>	<b>15</b>
4.1. MISA's Retry Mode .....	15
4.2. MISA Error Generation .....	15
4.3. MISA's PC/PCI Support .....	15
<b>5.0. PINOUT INFORMATION .....</b>	<b>16</b>
<b>6.0. MISA PACKAGE INFORMATION .....</b>	<b>19</b>
<b>7.0. TESTABILITY .....</b>	<b>20</b>











































