

Accelerating Silicon Design with the Intel® Xeon® Processor E7-4800 Product Family

- 1.35x increased throughput compared with Intel® Xeon® processor 7500 series.
- 7.81x increased throughput compared with Intel® Xeon® processor 7100 series.

Silicon design is one of the most critical business functions at Intel—and it requires significant computing resources. Larger and more compute-intensive design jobs require four-socket servers, which offer greater processing power and memory capacity to help ensure these long-running jobs are completed to meet critical design timelines. Accordingly, large-memory four-socket servers are an essential component of the Intel IT high-performance computing (HPC) silicon design environment.

Intel IT recently conducted tests to assess the potential benefits to silicon design of four-socket servers based on the Intel® Xeon® processor E7-4800 product family. These servers include up to 10 cores and 30 MB last-level cache per processor—25 percent more than the previous generation. They also provide 2x the maximum memory, by supporting 32-GB DIMMs,¹ for application workloads that require large memory capacity. Our tests used a large multi-threaded electronic design automation (EDA) application operating on current Intel silicon design datasets.

This new server completed a complex silicon design workload 1.35x faster than a server based on the Intel® Xeon® processor 7500 series and 7.81x faster than a server based on the Intel® Xeon® processor 7100 series, as shown in Figure 1.

Based on our results, the Intel Xeon processor E7-4800 product family offers significant throughput improvements compared to prior generations; these improvements can accelerate long-running silicon design jobs, thereby helping to reduce the time required to bring new silicon designs to market.

¹ Intel IT tests used 8-GB DIMMs.

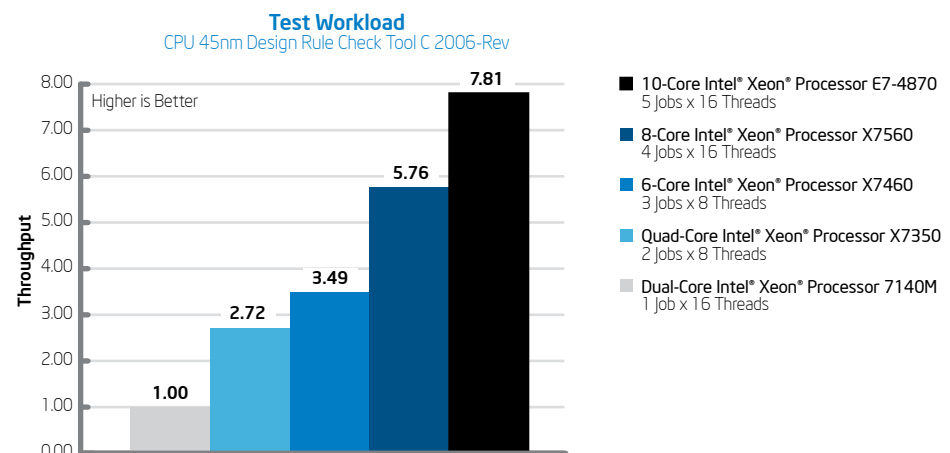

Figure 1. Four-socket servers based on the Intel® Xeon® processor E7-4800 product family completed silicon design workloads 7.81x faster than previous generation processors in Intel IT tests. Intel internal measurements, March 2010 and March 2011.

Business Challenge

To continue to deliver on the promise of Moore’s Law, silicon chip design engineers at Intel face the challenges of integrating more features into ever-shrinking silicon chips, bringing products to market more quickly, and keeping design engineering and manufacturing costs low. As design complexity increases, the requirements for compute capacity also increase; therefore, refreshing servers and workstations with faster systems is cost effective and offers a competitive advantage by enabling faster chip design.

The largest, most compute-intensive back-end design jobs require servers with considerable processing power, memory capacity, and memory bandwidth. Servers also must provide higher availability, along with support for large local disk drives, to help ensure completion of these long-running design jobs to meet critical design timelines.

We conducted performance comparison tests using EDA applications and current silicon design workloads to evaluate the potential of servers based on the Intel Xeon processor E7-4800 product family to accelerate silicon design compared with servers based on previous processors.

The Intel Xeon processor E7-4800 product family includes new features that can increase

EDA throughput, including up to 10 cores and up to 30 MB of last-level cache—25 percent more than previous generations of processors. Four-socket servers based on these processors include up to 40 cores and can run up to 80 simultaneous threads using Intel® Hyper-Threading Technology (Intel® HT Technology). They provide 2x the memory capacity compared with previous generations, supporting up to 512 GB of memory per socket using 16 32-GB DIMMs (a total of 2 TB of memory per server), with up to 102 Gb/s memory bandwidth. A four-socket platform based on Intel Xeon processor E7-4800 product family is shown in Figure 2, along with the previous generations for comparison.

The Intel Xeon processor E7-4800 product family is more energy-efficient than previous generations, delivering increased performance within the same power envelope due to the use of 32nm process technology and features such as Intel® Intelligent Power Technology, which automatically shifts the CPU and memory into the lowest available power state.

The purpose of our tests was to measure the EDA application throughput improvement we could achieve using servers based on the Intel Xeon processor E7-4800 product family. Increased EDA throughput would enable us to

accelerate key design tasks and potentially bring products to market more quickly.

Test Methodology

We ran tests using an industry-leading design rule check (DRC) EDA application operating on our chip design workloads on four-socket servers based on different Intel® processor generations:

- Intel® Xeon® processor 7140M with two cores
- Intel® Xeon® processor X7350 with four cores
- Intel® Xeon® processor X7460 with six cores
- Intel® Xeon® processor X7560 with eight cores
- Intel® Xeon® processor E7-4870 with 10 cores

Test configurations are shown in Table 1.

We recorded throughput for each platform, measuring and comparing the time taken to complete a specific number of design workloads.

To maximize throughput, we configured the application to utilize all the available cores. This resulted in multiple simultaneous jobs on each platform, as shown in Table 2. We enabled Intel HT Technology where available; this provided 80 logical cores on the server based on Intel Xeon processor E7-4870, enabling us to run five 16-threaded jobs simultaneously.

Table 1. Test System Specifications

	Intel® Xeon® Processor 7140M	Intel® Xeon® Processor X7350	Intel® Xeon® Processor X7460	Intel® Xeon® Processor X7560	Intel® Xeon® Processor E7-4870
Cores per Processor	2	4	6	8	10
Speed	3.4 GHz	2.93 GHz	2.66 GHz	2.26 GHz	2.4 GHz
Process Technology	65nm	65nm	45nm	45nm	32nm
Last-level Cache per Processor	16 MB	2x 4 MB	16 MB	24 MB	30 MB
Intel® Turbo Boost Technology	N/A	N/A	N/A	Enabled	Enabled
Hyper-Threading	Enabled	N/A	N/A	Enabled	Enabled
NUMA Mode	N/A	N/A	N/A	Enabled	Enabled
Chipset	Intel® E8501	Intel® 7300	Intel® 7300	Intel® 7500	Intel® 7500
Front Side Bus/Intel® QPI Speed	800 MHz Dual Shared	1066 MHz DHSI	1066 MHz DHSI	6.4 GT/s Intel QPI	6.4 GT/s Intel QPI
RAM	64 GB (16x 4 GB)	128 GB (32x 4 GB)	128 GB (32x 4 GB)	256 GB (64x 4 GB)	512 GB (64x 8 GB)
RAM Type	DDR2-400	FB-DIMM-667	FB-DIMM-667	DDR3-1333 ^o	DDR3-1333 ^o
Hard Drives	2x 73 GB 10K RPM SCSI	2x 73 GB 10K RPM SAS	2x 73 GB 10K RPM SAS	2x 146 GB 10K RPM SAS	2x 146 GB 10K RPM SAS

DDR - double data rate; DHSI - dedicated high speed interconnect; FB-DIMM - fully buffered dual in-line memory module; Intel® QPI - Intel® QuickPath Interconnect; NUMA - non-uniform memory access

^o On Intel Xeon processor X7560 and Intel Xeon processor E7-4870, DDR3-1333 RAM runs at 1066 MHz.

Four-Socket Server Based on Intel® Xeon® Processor 7100 Series with Intel® E8501 Chipset

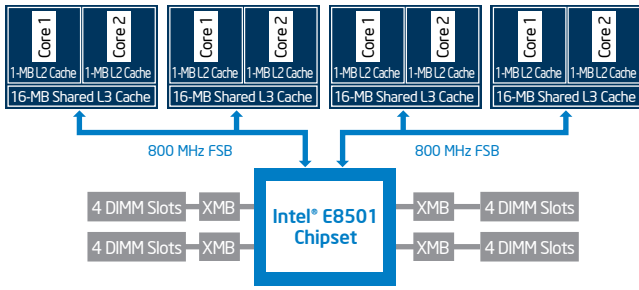

Four-Socket Server Based on Intel® Xeon® Processor 7300 Series with Intel® 7300 Chipset

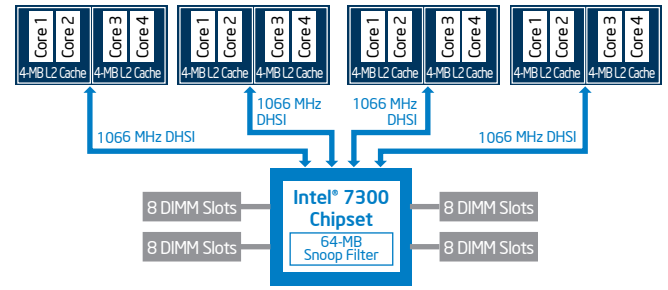

Four-Socket Server Based on Intel® Xeon® Processor 7400 Series with Intel® 7300 Chipset

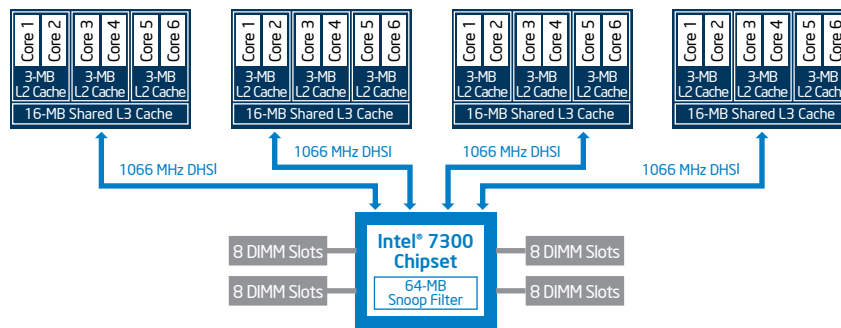

Four-Socket Server Based on Intel® Xeon® Processor 7500 Series with Intel® 7500 Chipset

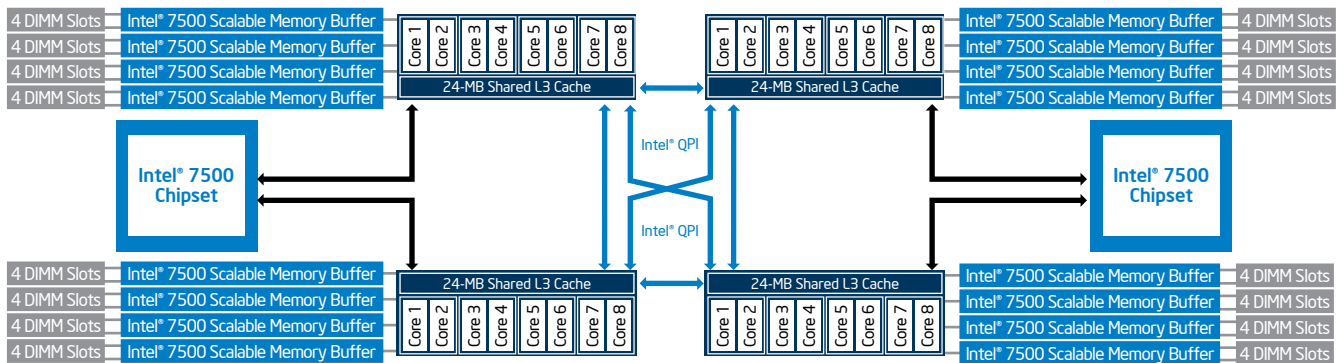

Four-Socket Server Based on Intel® Xeon® Processor E7-4800 Product Family with Intel® 7500 Chipset

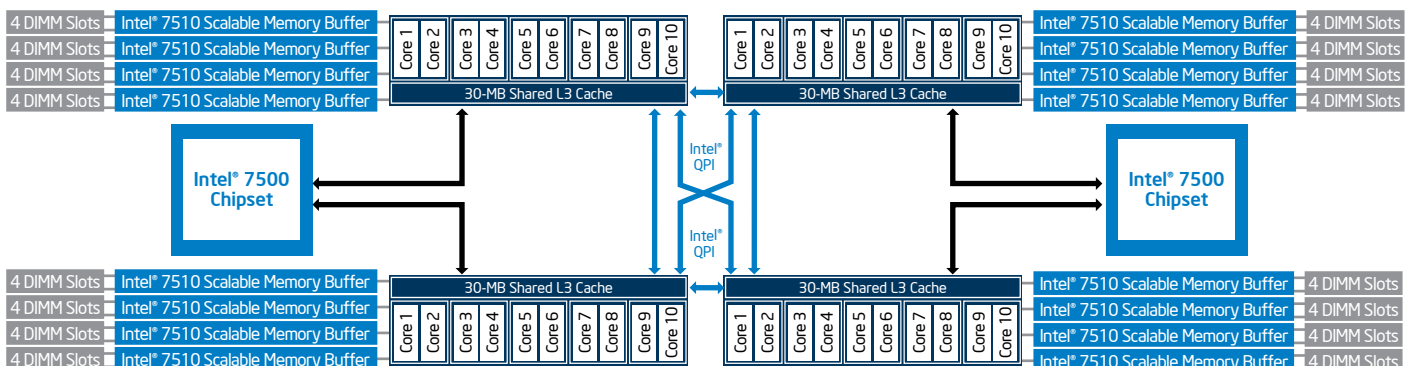

DHSI - dedicated high speed interconnect; DIMM - dual in-line memory module; FSB - front side bus; Intel® QPI - Intel® QuickPath Interconnect at 6.4 GT/s; XMB - eXternal memory bridge

Figure 2. Four-socket servers based on different generations of Intel® Xeon® processors.

Table 2. Results of Intel IT Tests Comparing Throughput of Four-Socket Servers Running Electronic Design Automation (EDA) Applications

Design Rule Check Application - CPU 45nm Design Testcase; 43 GB Peak Memory Per Job					
	Intel® Xeon® Processor 7140M	Intel® Xeon® Processor X7350	Intel® Xeon® Processor X7460	Intel® Xeon® Processor X7560	Intel® Xeon® Processor E7-4870
Number of Jobs and Threads per Iteration	1 Job x 16 Threads/Job	2 Jobs x 8 Threads/Job	3 Jobs x 8 Threads/Job	4 Jobs x 16 Threads/Job	5 Jobs x 16 Threads/Job
Total Iterations Needed to Complete 60 Jobs	60	30	20	15	12
Total Time to Complete 60 Jobs	597:26:00	219:27:00	171:02:40	103:41:08	76:31:43
Relative Throughput	1.00	2.72	3.49	5.76	7.81

Results

With 1.25x as many cores as the previous-generation system based on Intel Xeon processor X7560, the server based on Intel Xeon processor E7-4870 completed the workloads 1.35x faster, representing a greater-than-linear increase in throughput. It was 7.81x faster than the system based on Intel Xeon processor 7140M. Results are shown in Table 2 and Figure 1.

Conclusion

The Intel Xeon processor E7-4800 product family has the potential to deliver significant benefits for silicon design at Intel. Our testing indicated that servers based on the Intel Xeon processor E7-4800 product family could be a very efficient platform for our large design workloads; the server based on this product family delivered a greater-than-linear performance increase, relative to the growth in the number of cores and cache size, compared with the previous server generation based on Intel Xeon processor 7500 series.

We anticipate that the faster performance will allow engineers to accelerate key design tasks

in Intel's HPC environment, potentially helping us to bring products to market more quickly.

Our results suggest that other technical applications with large memory requirements, such as simulation and verification applications in the auto, aeronautical, oil and gas, and life sciences industries, could see similar improvements.

Systems based on the Intel Xeon processor E7-4800 product family are also expected to help control operational and software licensing costs by achieving greater throughput using fewer systems than were necessary with previous generations of processors. Based on our results, two new servers based on Intel Xeon processor E7-4870 could replace up to 15 older servers based on Intel Xeon processor 7140M.

Based on our evaluation, we plan to deploy systems based on Intel Xeon processor E7-4800 product family in order to achieve these benefits for our silicon design teams and for Intel IT.

AUTHORS

Shesha Krishnapura
Senior Principal Engineer, Intel IT

Vipul Lal
Senior Principal Engineer, Intel IT

Shaji Achuthan
Senior Staff Engineer, Intel IT

Ty Tang
Senior Principal Engineer, Intel IT

Ajay Chandramouly
Industry Engagement Manager, Intel IT

For more straight talk on current topics from Intel's IT leaders, visit www.intel.com/it.

Performance tests and ratings are measured using specific computer systems and/or components and reflect the approximate performance of Intel products as measured by those tests. Any difference in system hardware or software design or configuration may affect actual performance. Buyers should consult other sources of information to evaluate the performance of systems or components they are considering purchasing. For more information on performance tests and on the performance of Intel products, reference www.intel.com/performance/resources/benchmark_limitations.htm or call (U.S.) 1-800-628-8686 or 1-916-356-3104.

Intel processor numbers are not a measure of performance. Processor numbers differentiate features within each processor family, not across different processor families. Go to: http://www.intel.com/products/processor_number

This paper is for informational purposes only. THIS DOCUMENT IS PROVIDED "AS IS" WITH NO WARRANTIES WHATSOEVER, INCLUDING ANY

WARRANTY OF MERCHANTABILITY, NON-INFRINGEMENT, FITNESS FOR ANY PARTICULAR PURPOSE, OR ANY WARRANTY OTHERWISE ARISING OUT OF ANY PROPOSAL, SPECIFICATION OR SAMPLE. Intel disclaims all liability, including liability for infringement of any proprietary rights, relating to use of information in this specification. No license, express or implied, by estoppel or otherwise, to any intellectual property rights is granted herein.

Intel, the Intel logo, and Xeon are trademarks of Intel Corporation in the U.S. and other countries.

* Other names and brands may be claimed as the property of others.

Copyright © 2011 Intel Corporation. All rights reserved.

Printed in USA
0411/ABC/KC/PDF

 Please Recycle
324594-001US

