

---

# **Sample Applications User Guide**

*Release 2.0.0*

April 24, 2015

<b>1</b>	<b>Introduction</b>	<b>2</b>
1.1	Documentation Roadmap . . . . .	2
<b>2</b>	<b>Command Line Sample Application</b>	<b>3</b>
2.1	Overview . . . . .	3
2.2	Compiling the Application . . . . .	3
2.3	Running the Application . . . . .	4
2.4	Explanation . . . . .	4
<b>3</b>	<b>Exception Path Sample Application</b>	<b>6</b>
3.1	Overview . . . . .	6
3.2	Compiling the Application . . . . .	7
3.3	Running the Application . . . . .	7
3.4	Explanation . . . . .	8
<b>4</b>	<b>Hello World Sample Application</b>	<b>12</b>
4.1	Compiling the Application . . . . .	12
4.2	Running the Application . . . . .	12
4.3	Explanation . . . . .	12
<b>5</b>	<b>Basic Forwarding Sample Application</b>	<b>14</b>
5.1	Compiling the Application . . . . .	14
5.2	Running the Application . . . . .	14
5.3	Explanation . . . . .	14
<b>6</b>	<b>RX/TX Callbacks Sample Application</b>	<b>19</b>
6.1	Compiling the Application . . . . .	19
6.2	Running the Application . . . . .	19
6.3	Explanation . . . . .	20
<b>7</b>	<b>IP Fragmentation Sample Application</b>	<b>23</b>
7.1	Overview . . . . .	23
7.2	Building the Application . . . . .	23
7.3	Running the Application . . . . .	24
<b>8</b>	<b>IPv4 Multicast Sample Application</b>	<b>26</b>
8.1	Overview . . . . .	26
8.2	Building the Application . . . . .	26
8.3	Running the Application . . . . .	27
8.4	Explanation . . . . .	27

<b>9</b>	<b>IP Reassembly Sample Application</b>	<b>32</b>
9.1	Overview . . . . .	32
9.2	The Longest Prefix Match (LPM for IPv4, LPM6 for IPv6) table is used to store/lookup an outgoing port number, associated with that IPv4 address. Any unmatched packets are forwarded to the originating port. Compiling the Application . . . . .	32
9.3	Running the Application . . . . .	33
9.4	Explanation . . . . .	34
<b>10</b>	<b>Kernel NIC Interface Sample Application</b>	<b>37</b>
10.1	Overview . . . . .	37
10.2	Compiling the Application . . . . .	38
10.3	Loading the Kernel Module . . . . .	38
10.4	Running the Application . . . . .	39
10.5	KNI Operations . . . . .	40
10.6	Explanation . . . . .	40
<b>11</b>	<b>L2 Forwarding Sample Application (in Real and Virtualized Environments) with core load statistics.</b>	<b>47</b>
11.1	Overview . . . . .	47
11.2	Compiling the Application . . . . .	49
11.3	Running the Application . . . . .	49
11.4	Explanation . . . . .	49
<b>12</b>	<b>L2 Forwarding Sample Application (in Real and Virtualized Environments)</b>	<b>58</b>
12.1	Overview . . . . .	58
12.2	Compiling the Application . . . . .	60
12.3	Running the Application . . . . .	60
12.4	Explanation . . . . .	60
<b>13</b>	<b>L3 Forwarding Sample Application</b>	<b>67</b>
13.1	Overview . . . . .	67
13.2	Compiling the Application . . . . .	67
13.3	Running the Application . . . . .	68
13.4	Explanation . . . . .	69
<b>14</b>	<b>L3 Forwarding with Power Management Sample Application</b>	<b>73</b>
14.1	Introduction . . . . .	73
14.2	Overview . . . . .	73
14.3	Compiling the Application . . . . .	74
14.4	Running the Application . . . . .	75
14.5	Explanation . . . . .	75
<b>15</b>	<b>L3 Forwarding with Access Control Sample Application</b>	<b>80</b>
15.1	Overview . . . . .	80
15.2	Compiling the Application . . . . .	84
15.3	Running the Application . . . . .	84
15.4	Explanation . . . . .	85
<b>16</b>	<b>L3 Forwarding in a Virtualization Environment Sample Application</b>	<b>87</b>
16.1	Overview . . . . .	87
16.2	Compiling the Application . . . . .	87
16.3	Running the Application . . . . .	88

16.4	Explanation . . . . .	89
<b>17</b>	<b>Link Status Interrupt Sample Application</b>	<b>90</b>
17.1	Overview . . . . .	90
17.2	Compiling the Application . . . . .	90
17.3	Running the Application . . . . .	91
17.4	Explanation . . . . .	91
<b>18</b>	<b>Load Balancer Sample Application</b>	<b>98</b>
18.1	Overview . . . . .	98
18.2	Compiling the Application . . . . .	99
18.3	Running the Application . . . . .	99
18.4	Explanation . . . . .	100
<b>19</b>	<b>Multi-process Sample Application</b>	<b>103</b>
19.1	Example Applications . . . . .	103
<b>20</b>	<b>QoS Metering Sample Application</b>	<b>118</b>
20.1	Overview . . . . .	118
20.2	Compiling the Application . . . . .	118
20.3	Running the Application . . . . .	119
20.4	Explanation . . . . .	119
<b>21</b>	<b>QoS Scheduler Sample Application</b>	<b>121</b>
21.1	Overview . . . . .	121
21.2	Compiling the Application . . . . .	121
21.3	Running the Application . . . . .	122
21.4	Explanation . . . . .	125
<b>22</b>	<b>Intel® QuickAssist Technology Sample Application</b>	<b>127</b>
22.1	Overview . . . . .	127
22.2	Building the Application . . . . .	129
22.3	Running the Application . . . . .	129
<b>23</b>	<b>Quota and Watermark Sample Application</b>	<b>131</b>
23.1	Overview . . . . .	131
23.2	Compiling the Application . . . . .	133
23.3	Running the Application . . . . .	133
23.4	Code Overview . . . . .	134
<b>24</b>	<b>Timer Sample Application</b>	<b>141</b>
24.1	Compiling the Application . . . . .	141
24.2	Running the Application . . . . .	141
24.3	Explanation . . . . .	141
<b>25</b>	<b>Packet Ordering Application</b>	<b>145</b>
25.1	Overview . . . . .	145
25.2	Compiling the Application . . . . .	145
25.3	Running the Application . . . . .	145
<b>26</b>	<b>VMDQ and DCB Forwarding Sample Application</b>	<b>147</b>
26.1	Overview . . . . .	147
26.2	Compiling the Application . . . . .	148

26.3	Running the Application . . . . .	148
26.4	Explanation . . . . .	149
<b>27</b>	<b>Vhost Sample Application</b>	<b>152</b>
27.1	Background . . . . .	152
27.2	Sample Code Overview . . . . .	154
27.3	Supported Distributions . . . . .	154
27.4	Prerequisites . . . . .	154
27.5	Compiling the Sample Code . . . . .	159
27.6	Running the Sample Code . . . . .	159
27.7	Running the Virtual Machine (QEMU) . . . . .	162
27.8	Running DPDK in the Virtual Machine . . . . .	165
27.9	Passing Traffic to the Virtual Machine Device . . . . .	167
<b>28</b>	<b>Netmap Compatibility Sample Application</b>	<b>168</b>
28.1	Introduction . . . . .	168
28.2	Available APIs . . . . .	168
28.3	Caveats . . . . .	168
28.4	Porting Netmap Applications . . . . .	169
28.5	Compiling the “bridge” Sample Application . . . . .	170
28.6	Running the “bridge” Sample Application . . . . .	170
<b>29</b>	<b>Internet Protocol (IP) Pipeline Sample Application</b>	<b>171</b>
29.1	Overview . . . . .	171
29.2	Compiling the Application . . . . .	171
29.3	Running the Sample Code . . . . .	171
<b>30</b>	<b>Test Pipeline Application</b>	<b>173</b>
30.1	Overview . . . . .	173
30.2	Compiling the Application . . . . .	173
30.3	Running the Application . . . . .	174
<b>31</b>	<b>Distributor Sample Application</b>	<b>177</b>
31.1	Overview . . . . .	177
31.2	Compiling the Application . . . . .	178
31.3	Running the Application . . . . .	178
31.4	Explanation . . . . .	178
31.5	Debug Logging Support . . . . .	179
31.6	Statistics . . . . .	179
31.7	Application Initialization . . . . .	180
<b>32</b>	<b>VM Power Management Application</b>	<b>181</b>
32.1	Introduction . . . . .	181
32.2	Overview . . . . .	183
32.3	Configuration . . . . .	184
32.4	Compiling and Running the Host Application . . . . .	185
32.5	Compiling and Running the Guest Applications . . . . .	186

April 24, 2015

**Contents**

## INTRODUCTION

This document describes the sample applications that are included in the Data Plane Development Kit (DPDK). Each chapter describes a sample application that showcases specific functionality and provides instructions on how to compile, run and use the sample application.

### 1.1 Documentation Roadmap

The following is a list of DPDK documents in suggested reading order:

- **Release Notes** : Provides release-specific information, including supported features, limitations, fixed issues, known issues and so on. Also, provides the answers to frequently asked questions in FAQ format.
- **Getting Started Guides** : Describes how to install and configure the DPDK software for your operating system; designed to get users up and running quickly with the software.
- **Programmer's Guide**: Describes:
  - The software architecture and how to use it (through examples), specifically in a Linux\* application (linuxapp) environment.
  - The content of the DPDK, the build system (including the commands that can be used in the root DPDK Makefile to build the development kit and an application) and guidelines for porting an application.
  - Optimizations used in the software and those that should be considered for new development

A glossary of terms is also provided.

- **API Reference** : Provides detailed information about DPDK functions, data structures and other programming constructs.
- **Sample Applications User Guide** : Describes a set of sample applications. Each chapter describes a sample application that showcases specific functionality and provides instructions on how to compile, run and use the sample application.

## COMMAND LINE SAMPLE APPLICATION

This chapter describes the Command Line sample application that is part of the Data Plane Development Kit (DPDK).

### 2.1 Overview

The Command Line sample application is a simple application that demonstrates the use of the command line interface in the DPDK. This application is a readline-like interface that can be used to debug a DPDK application, in a Linux\* application environment.

---

**Note:** The `rte_cmdline` library should not be used in production code since it is not validated to the same standard as other Intel® DPDK libraries. See also the “`rte_cmdline` library should not be used in production code due to limited testing” item in the “Known Issues” section of the Release Notes.

---

The Command Line sample application supports some of the features of the GNU readline library such as, completion, cut/paste and some other special bindings that make configuration and debug faster and easier.

The application shows how the `rte_cmdline` application can be extended to handle a list of objects. There are three simple commands:

- `add obj_name IP`: Add a new object with an IP/IPv6 address associated to it.
- `del obj_name`: Delete the specified object.
- `show obj_name`: Show the IP associated with the specified object.

---

**Note:** To terminate the application, use **Ctrl-d**.

---

### 2.2 Compiling the Application

1. Go to example directory:

```
export RTE_SDK=/path/to/rte_sdk
cd ${RTE_SDK}/examples/cmdline
```

2. Set the target (a default target is used if not specified). For example:

```
export RTE_TARGET=x86_64-native-linuxapp-gcc
```



Refer to the *DPDK Getting Started Guide* for possible RTE\_TARGET values.

3. Build the application:

```
make
```

## 2.3 Running the Application

To run the application in linuxapp environment, issue the following command:

```
$ ./build/cmdline -c f -n 4
```

Refer to the *DPDK Getting Started Guide* for general information on running applications and the Environment Abstraction Layer (EAL) options.

## 2.4 Explanation

The following sections provide some explanation of the code.

### 2.4.1 EAL Initialization and cmdline Start

The first task is the initialization of the Environment Abstraction Layer (EAL). This is achieved as follows:

```
int main(int argc, char **argv)
{
    ret = rte_eal_init(argc, argv);
    if (ret < 0)
        rte_panic("Cannot init EAL\n");
}
```

Then, a new command line object is created and started to interact with the user through the console:

```
cl = cmdline_stdin_new(main_ctx, "example> ");
cmdline_interact(cl);
cmdline_stdin_exit(cl);
```

The `cmd_line_interact()` function returns when the user types **Ctrl-d** and in this case, the application exits.

### 2.4.2 Defining a cmdline Context

A cmdline context is a list of commands that are listed in a NULL-terminated table, for example:

```
cmdline_parse_ctx_t main_ctx[] = {
    (cmdline_parse_inst_t *) &cmd_obj_del_show,
    (cmdline_parse_inst_t *) &cmd_obj_add,
    (cmdline_parse_inst_t *) &cmd_help,
    NULL,
};
```

Each command (of type `cmdline_parse_inst_t`) is defined statically. It contains a pointer to a callback function that is executed when the command is parsed, an opaque pointer, a help string and a list of tokens in a NULL-terminated table.

The `rte_cmdline` application provides a list of pre-defined token types:

- String Token: Match a static string, a list of static strings or any string.
- Number Token: Match a number that can be signed or unsigned, from 8-bit to 32-bit.
- IP Address Token: Match an IPv4 or IPv6 address or network.
- Ethernet\* Address Token: Match a MAC address.

In this example, a new token type `obj_list` is defined and implemented in the `parse_obj_list.c` and `parse_obj_list.h` files.

For example, the `cmd_obj_del_show` command is defined as shown below:

```

struct cmd_obj_add_result {
    cmdline_fixed_string_t action;
    cmdline_fixed_string_t name;
    struct object *obj;
};

static void cmd_obj_del_show_parsed(void *parsed_result, struct cmdline *cl, attribute ((unused))
{
    /* ... */
}

cmdline_parse_token_string_t cmd_obj_action = TOKEN_STRING_INITIALIZER(struct cmd_obj_del_show
parse_token_obj_list_t cmd_obj_obj = TOKEN_OBJ_LIST_INITIALIZER(struct cmd_obj_del_show_result

cmdline_parse_inst_t cmd_obj_del_show = {
    .f = cmd_obj_del_show_parsed, /* function to call */
    .data = NULL, /* 2nd arg of func */
    .help_str = "Show/del an object",
    .tokens = { /* token list, NULL terminated */
        (void *)&cmd_obj_action,
        (void *)&cmd_obj_obj,
        NULL,
    },
};

```

This command is composed of two tokens:

- The first token is a string token that can be show or del.
- The second token is an object that was previously added using the add command in the `global_obj_list` variable.

Once the command is parsed, the `rte_cmdline` application fills a `cmd_obj_del_show_result` structure. A pointer to this structure is given as an argument to the callback function and can be used in the body of this function.

## EXCEPTION PATH SAMPLE APPLICATION

The Exception Path sample application is a simple example that demonstrates the use of the DPDK to set up an exception path for packets to go through the Linux\* kernel. This is done by using virtual TAP network interfaces. These can be read from and written to by the DPDK application and appear to the kernel as a standard network interface.

### 3.1 Overview

The application creates two threads for each NIC port being used. One thread reads from the port and writes the data unmodified to a thread-specific TAP interface. The second thread reads from a TAP interface and writes the data unmodified to the NIC port.

The packet flow through the exception path application is as shown in the following figure.

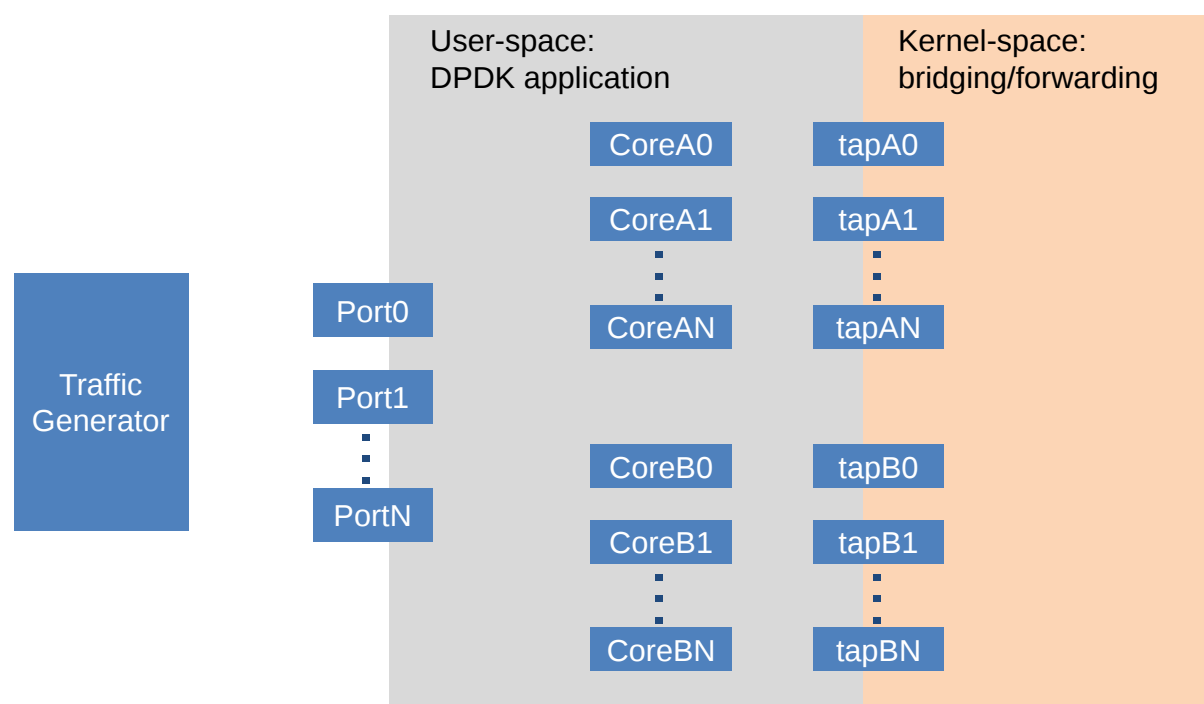

Figure 3.1: Packet Flow

To make throughput measurements, kernel bridges must be setup to forward data between the bridges appropriately.

## 3.2 Compiling the Application

1. Go to example directory:

```
export RTE_SDK=/path/to/rte_sdk
cd ${RTE_SDK}/examples/exception_path
```

2. Set the target (a default target will be used if not specified). For example:

```
export RTE_TARGET=x86_64-native-linuxapp-gcc
```

This application is intended as a linuxapp only. See the *DPDK Getting Started Guide* for possible RTE\_TARGET values.

1. Build the application:

```
make
```

## 3.3 Running the Application

The application requires a number of command line options:

```
./build/exception_path [EAL options] -- -p PORTMASK -i IN_CORES -o OUT_CORES
```

where:

- -p PORTMASK: A hex bitmask of ports to use
- -i IN\_CORES: A hex bitmask of cores which read from NIC
- -o OUT\_CORES: A hex bitmask of cores which write to NIC

Refer to the *DPDK Getting Started Guide* for general information on running applications and the Environment Abstraction Layer (EAL) options.

The number of bits set in each bitmask must be the same. The coremask -c parameter of the EAL options should include IN\_CORES and OUT\_CORES. The same bit must not be set in IN\_CORES and OUT\_CORES. The affinities between ports and cores are set beginning with the least significant bit of each mask, that is, the port represented by the lowest bit in PORTMASK is read from by the core represented by the lowest bit in IN\_CORES, and written to by the core represented by the lowest bit in OUT\_CORES.

For example to run the application with two ports and four cores:

```
./build/exception_path -c f -n 4 -- -p 3 -i 3 -o c
```

### 3.3.1 Getting Statistics

While the application is running, statistics on packets sent and received can be displayed by sending the SIGUSR1 signal to the application from another terminal:

```
killall -USR1 exception_path
```

The statistics can be reset by sending a SIGUSR2 signal in a similar way.

## 3.4 Explanation

The following sections provide some explanation of the code.

### 3.4.1 Initialization

Setup of the mbuf pool, driver and queues is similar to the setup done in the L2 Forwarding sample application (see Chapter 9 “L2 forwarding Sample Application (in Real and Virtualized Environments” for details). In addition, the TAP interfaces must also be created. A TAP interface is created for each lcore that is being used. The code for creating the TAP interface is as follows:

```

/*
 * Create a tap network interface, or use existing one with same name.
 * If name[0]='\0' then a name is automatically assigned and returned in name.
 */
static int tap_create(char *name)
{
    struct ifreq ifr;
    int fd, ret;

    fd = open("/dev/net/tun", O_RDWR);
    if (fd < 0)
        return fd;

    memset(&ifr, 0, sizeof(ifr));

    /* TAP device without packet information */

    ifr.ifr_flags = IFF_TAP | IFF_NO_PI;
    if (name && *name)
        rte_snprintf(ifr.ifr_name, IFNAMSIZ, name);

    ret = ioctl(fd, TUNSETIFF, (void *) &ifr);

    if (ret < 0) {
        close(fd);
        return ret;
    }

    if (name)
        rte_snprintf(name, IFNAMSIZ, ifr.ifr_name);

    return fd;
}

```

The other step in the initialization process that is unique to this sample application is the association of each port with two cores:

- One core to read from the port and write to a TAP interface
- A second core to read from a TAP interface and write to the port

This is done using an array called `port_ids[]`, which is indexed by the lcore IDs. The population of this array is shown below:

```

tx_port = 0;
rx_port = 0;

```

```

RTE_LCORE_FOREACH(i) {
    if (input_cores_mask & (1ULL << i)) {
        /* Skip ports that are not enabled */
        while ((ports_mask & (1 << rx_port)) == 0) {
            rx_port++;
            if (rx_port > (sizeof(ports_mask) * 8))
                goto fail; /* not enough ports */
        }
        port_ids[i] = rx_port++;
    } else if (output_cores_mask & (1ULL << i)) {
        /* Skip ports that are not enabled */
        while ((ports_mask & (1 << tx_port)) == 0) {
            tx_port++;
            if (tx_port > (sizeof(ports_mask) * 8))
                goto fail; /* not enough ports */
        }
        port_ids[i] = tx_port++;
    }
}

```

### 3.4.2 Packet Forwarding

After the initialization steps are complete, the `main_loop()` function is run on each lcore. This function first checks the `lcore_id` against the user provided `input_cores_mask` and `output_cores_mask` to see if this core is reading from or writing to a TAP interface.

For the case that reads from a NIC port, the packet reception is the same as in the L2 Forwarding sample application (see Section *Receive, Process and Transmit Packets*). The packet transmission is done by calling `write()` with the file descriptor of the appropriate TAP interface and then explicitly freeing the mbuf back to the pool.

```

/* Loop forever reading from NIC and writing to tap */
for (;;) {
    struct rte_mbuf *pkts_burst[PKT_BURST_SZ];
    unsigned i;

    const unsigned nb_rx = rte_eth_rx_burst(port_ids[lcore_id], 0, pkts_burst, PKT_BURST_SZ);

    lcore_stats[lcore_id].rx += nb_rx;

    for (i = 0; likely(i < nb_rx); i++) {
        struct rte_mbuf *m = pkts_burst[i];
        int ret = write(tap_fd, rte_pktmbuf_mtod(m, void*),
            rte_pktmbuf_data_len(m));
        rte_pktmbuf_free(m);
        if (unlikely(ret < 0))
            lcore_stats[lcore_id].dropped++;
        else
            lcore_stats[lcore_id].tx++;
    }
}

```

For the other case that reads from a TAP interface and writes to a NIC port, packets are retrieved by doing a `read()` from the file descriptor of the appropriate TAP interface. This fills in the data into the mbuf, then other fields are set manually. The packet can then be transmitted as normal.

```

/* Loop forever reading from tap and writing to NIC */
for (;;) {
    int ret;
    struct rte_mbuf *m = rte_pktmbuf_alloc(pktmbuf_pool);

    if (m == NULL)
        continue;

    ret = read(tap_fd, m->pkt.data, MAX_PACKET_SZ); lcore_stats[lcore_id].rx++;
    if (unlikely(ret < 0)) {
        FATAL_ERROR("Reading from %s interface failed", tap_name);
    }

    m->pkt.nb_segs = 1;
    m->pkt.next = NULL;
    m->pkt.data_len = (uint16_t)ret;

    ret = rte_eth_tx_burst(port_ids[lcore_id], 0, &m, 1);
    if (unlikely(ret < 1)) {
        rte_pktmbuf_free(m);
        lcore_stats[lcore_id].dropped++;
    }
    else {
        lcore_stats[lcore_id].tx++;
    }
}
}

```

To set up loops for measuring throughput, TAP interfaces can be connected using bridging. The steps to do this are described in the section that follows.

### 3.4.3 Managing TAP Interfaces and Bridges

The Exception Path sample application creates TAP interfaces with names of the format `tap_dpdk_nn`, where `nn` is the `lcore` ID. These TAP interfaces need to be configured for use:

```
ifconfig tap_dpdk_00 up
```

To set up a bridge between two interfaces so that packets sent to one interface can be read from another, use the `brctl` tool:

```
brctl addbr "br0"
brctl addif br0 tap_dpdk_00
brctl addif br0 tap_dpdk_03
ifconfig br0 up
```

The TAP interfaces created by this application exist only when the application is running, so the steps above need to be repeated each time the application is run. To avoid this, persistent TAP interfaces can be created using `openvpn`:

```
openvpn --mktun --dev tap_dpdk_00
```

If this method is used, then the steps above have to be done only once and the same TAP interfaces can be reused each time the application is run. To remove bridges and persistent TAP interfaces, the following commands are used:

```
ifconfig br0 down
brctl delbr br0
```

```
openvpn --rmtun --dev tap_dpdk_00
```



## HELLO WORLD SAMPLE APPLICATION

The Hello World sample application is an example of the simplest DPDK application that can be written. The application simply prints an “helloworld” message on every enabled lcore.

### 4.1 Compiling the Application

1. Go to the example directory:

```
export RTE_SDK=/path/to/rte_sdk
cd ${RTE_SDK}/examples/helloworld
```

2. Set the target (a default target is used if not specified). For example:

```
export RTE_TARGET=x86_64-native-linuxapp-gcc
```

See the *DPDK Getting Started Guide* for possible RTE\_TARGET values.

3. Build the application:

```
make
```

### 4.2 Running the Application

To run the example in a linuxapp environment:

```
$ ./build/helloworld -c f -n 4
```

Refer to *DPDK Getting Started Guide* for general information on running applications and the Environment Abstraction Layer (EAL) options.

### 4.3 Explanation

The following sections provide some explanation of code.

#### 4.3.1 EAL Initialization

The first task is to initialize the Environment Abstraction Layer (EAL). This is done in the main() function using the following code:

```

int
main(int argc, char **argv)
{
    ret = rte_eal_init(argc, argv);
    if (ret < 0)
        rte_panic("Cannot init EAL\n");
}

```

This call finishes the initialization process that was started before `main()` is called (in case of a Linuxapp environment). The `argc` and `argv` arguments are provided to the `rte_eal_init()` function. The value returned is the number of parsed arguments.

### 4.3.2 Starting Application Unit Lcores

Once the EAL is initialized, the application is ready to launch a function on an lcore. In this example, `lcore_hello()` is called on every available lcore. The following is the definition of the function:

```

static int
lcore_hello( attribute ((unused)) void *arg)
{
    unsigned lcore_id;

    lcore_id = rte_lcore_id();
    printf("hello from core %u\n", lcore_id);
    return 0;
}

```

The code that launches the function on each lcore is as follows:

```

/* call lcore_hello() on every slave lcore */
RTE_LCORE_FOREACH_SLAVE(lcore_id) {
    rte_eal_remote_launch(lcore_hello, NULL, lcore_id);
}

/* call it on master lcore too */
lcore_hello(NULL);

```

The following code is equivalent and simpler:

```

rte_eal_mp_remote_launch(lcore_hello, NULL, CALL_MASTER);

```

Refer to the *DPDK API Reference* for detailed information on the `rte_eal_mp_remote_launch()` function.

## BASIC FORWARDING SAMPLE APPLICATION

The Basic Forwarding sample application is a simple *skeleton* example of a forwarding application.

It is intended as a demonstration of the basic components of a DPDK forwarding application. For more detailed implementations see the L2 and L3 forwarding sample applications.

### 5.1 Compiling the Application

To compile the application export the path to the DPDK source tree and go to the example directory:

```
export RTE_SDK=/path/to/rte_sdk
cd ${RTE_SDK}/examples/skeleton
```

Set the target, for example:

```
export RTE_TARGET=x86_64-native-linuxapp-gcc
```

See the *DPDK Getting Started Guide* for possible RTE\_TARGET values.

Build the application as follows:

```
make
```

### 5.2 Running the Application

To run the example in a `linuxapp` environment:

```
./build/basicfwd -c 2 -n 4
```

Refer to *DPDK Getting Started Guide* for general information on running applications and the Environment Abstraction Layer (EAL) options.

### 5.3 Explanation

The following sections provide an explanation of the main components of the code.

All DPDK library functions used in the sample code are prefixed with `rte_` and are explained in detail in the *DPDK API Documentation*.

### 5.3.1 The Main Function

The `main()` function performs the initialization and calls the execution threads for each lcore.

The first task is to initialize the Environment Abstraction Layer (EAL). The `argc` and `argv` arguments are provided to the `rte_eal_init()` function. The value returned is the number of parsed arguments:

```
int ret = rte_eal_init(argc, argv);
if (ret < 0)
    rte_exit(EXIT_FAILURE, "Error with EAL initialization\n");
```

The `main()` also allocates a mempool to hold the mbufs (Message Buffers) used by the application:

```
mbuf_pool = rte_mempool_create("MBUF POOL",
                              NUM_MBUFS * nb_ports,
                              MBUF_SIZE,
                              MBUF_CACHE_SIZE,
                              sizeof(struct rte_pktmbuf_pool_private),
                              rte_pktmbuf_pool_init, NULL,
                              rte_pktmbuf_init, NULL,
                              rte_socket_id(),
                              0);
```

Mbufs are the packet buffer structure used by DPDK. They are explained in detail in the “Mbuf Library” section of the *DPDK Programmer’s Guide*.

The `main()` function also initializes all the ports using the user defined `port_init()` function which is explained in the next section:

```
for (portid = 0; portid < nb_ports; portid++) {
    if (port_init(portid, mbuf_pool) != 0) {
        rte_exit(EXIT_FAILURE,
                 "Cannot init port %" PRIu8 "\n", portid);
    }
}
```

Once the initialization is complete, the application is ready to launch a function on an lcore. In this example `lcore_main()` is called on a single lcore.

```
lcore_main();
```

The `lcore_main()` function is explained below.

### 5.3.2 The Port Initialization Function

The main functional part of the port initialization used in the Basic Forwarding application is shown below:

```
static inline int
port_init(uint8_t port, struct rte_mempool *mbuf_pool)
{
    struct rte_eth_conf port_conf = port_conf_default;
```

```

const uint16_t rx_rings = 1, tx_rings = 1;
struct ether_addr addr;
int retval;
uint16_t q;

if (port >= rte_eth_dev_count())
    return -1;

/* Configure the Ethernet device. */
retval = rte_eth_dev_configure(port, rx_rings, tx_rings, &port_conf);
if (retval != 0)
    return retval;

/* Allocate and set up 1 RX queue per Ethernet port. */
for (q = 0; q < rx_rings; q++) {
    retval = rte_eth_rx_queue_setup(port, q, RX_RING_SIZE,
        rte_eth_dev_socket_id(port), NULL, mbuf_pool);
    if (retval < 0)
        return retval;
}

/* Allocate and set up 1 TX queue per Ethernet port. */
for (q = 0; q < tx_rings; q++) {
    retval = rte_eth_tx_queue_setup(port, q, TX_RING_SIZE,
        rte_eth_dev_socket_id(port), NULL);
    if (retval < 0)
        return retval;
}

/* Start the Ethernet port. */
retval = rte_eth_dev_start(port);
if (retval < 0)
    return retval;

/* Enable RX in promiscuous mode for the Ethernet device. */
rte_eth_promiscuous_enable(port);

return 0;
}

```

The Ethernet ports are configured with default settings using the `rte_eth_dev_configure()` function and the `port_conf_default` struct:

```

static const struct rte_eth_conf port_conf_default = {
    .rxmode = { .max_rx_pkt_len = ETHER_MAX_LEN }
};

```

For this example the ports are set up with 1 RX and 1 TX queue using the `rte_eth_rx_queue_setup()` and `rte_eth_tx_queue_setup()` functions.

The Ethernet port is then started:

```
retval = rte_eth_dev_start(port);
```

Finally the RX port is set in promiscuous mode:

```
rte_eth_promiscuous_enable(port);
```

### 5.3.3 The Lcores Main

As we saw above the `main()` function calls an application function on the available lcores. For the Basic Forwarding application the lcore function looks like the following:

```
static __attribute__((noreturn)) void
lcore_main(void)
{
    const uint8_t nb_ports = rte_eth_dev_count();
    uint8_t port;

    /*
     * Check that the port is on the same NUMA node as the polling thread
     * for best performance.
     */
    for (port = 0; port < nb_ports; port++)
        if (rte_eth_dev_socket_id(port) > 0 &&
            rte_eth_dev_socket_id(port) !=
                (int)rte_socket_id())
            printf("WARNING, port %u is on remote NUMA node to "
                  "polling thread.\n\tPerformance will "
                  "not be optimal.\n", port);

    printf("\nCore %u forwarding packets. [Ctrl+C to quit]\n",
          rte_lcore_id());

    /* Run until the application is quit or killed. */
    for (;;) {
        /*
         * Receive packets on a port and forward them on the paired
         * port. The mapping is 0 -> 1, 1 -> 0, 2 -> 3, 3 -> 2, etc.
         */
        for (port = 0; port < nb_ports; port++) {

            /* Get burst of RX packets, from first port of pair. */
            struct rte_mbuf *bufs[BURST_SIZE];
            const uint16_t nb_rx = rte_eth_rx_burst(port, 0,
                bufs, BURST_SIZE);

            if (unlikely(nb_rx == 0))
                continue;

            /* Send burst of TX packets, to second port of pair. */
            const uint16_t nb_tx = rte_eth_tx_burst(port ^ 1, 0,
                bufs, nb_rx);

            /* Free any unsend packets. */
            if (unlikely(nb_tx < nb_rx)) {
                uint16_t buf;
                for (buf = nb_tx; buf < nb_rx; buf++)
                    rte_pktmbuf_free(bufs[buf]);
            }
        }
    }
}
```

The main work of the application is done within the loop:

```
for (;;) {
    for (port = 0; port < nb_ports; port++) {

        /* Get burst of RX packets, from first port of pair. */
```

```
struct rte_mbuf *bufs[BURST_SIZE];
const uint16_t nb_rx = rte_eth_rx_burst(port, 0,
    bufs, BURST_SIZE);

if (unlikely(nb_rx == 0))
    continue;

/* Send burst of TX packets, to second port of pair. */
const uint16_t nb_tx = rte_eth_tx_burst(port ^ 1, 0,
    bufs, nb_rx);

/* Free any unsent packets. */
if (unlikely(nb_tx < nb_rx)) {
    uint16_t buf;
    for (buf = nb_tx; buf < nb_rx; buf++)
        rte_pktmbuf_free(bufs[buf]);
}
}
```

Packets are received in bursts on the RX ports and transmitted in bursts on the TX ports. The ports are grouped in pairs with a simple mapping scheme using the an XOR on the port number:

```
0 -> 1
1 -> 0

2 -> 3
3 -> 2

etc.
```

The `rte_eth_tx_burst()` function frees the memory buffers of packets that are transmitted. If packets fail to transmit, (`nb_tx < nb_rx`), then they must be freed explicitly using `rte_pktmbuf_free()`.

The forwarding loop can be interrupted and the application closed using `Ctrl-C`.

## RX/TX CALLBACKS SAMPLE APPLICATION

The RX/TX Callbacks sample application is a packet forwarding application that demonstrates the use of user defined callbacks on received and transmitted packets. The application performs a simple latency check, using callbacks, to determine the time packets spend within the application.

In the sample application a user defined callback is applied to all received packets to add a timestamp. A separate callback is applied to all packets prior to transmission to calculate the elapsed time, in CPU cycles.

### 6.1 Compiling the Application

To compile the application export the path to the DPDK source tree and go to the example directory:

```
export RTE_SDK=/path/to/rte_sdk
cd ${RTE_SDK}/examples/rxtx_callbacks
```

Set the target, for example:

```
export RTE_TARGET=x86_64-native-linuxapp-gcc
```

See the *DPDK Getting Started* Guide for possible `RTE_TARGET` values.

The callbacks feature requires that the `CONFIG_RTE_ETHDEV_RXTX_CALLBACKS` setting is on in the `config/common_config` file that applies to the target. This is generally on by default:

```
CONFIG_RTE_ETHDEV_RXTX_CALLBACKS=y
```

Build the application as follows:

```
make
```

### 6.2 Running the Application

To run the example in a `linuxapp` environment:

```
./build/rxtx_callbacks -c 2 -n 4
```



Refer to *DPDK Getting Started Guide* for general information on running applications and the Environment Abstraction Layer (EAL) options.

## 6.3 Explanation

The `rxtx_callbacks` application is mainly a simple forwarding application based on the *Basic Forwarding Sample Application*. See that section of the documentation for more details of the forwarding part of the application.

The sections below explain the additional RX/TX callback code.

### 6.3.1 The Main Function

The `main()` function performs the application initialization and calls the execution threads for each lcore. This function is effectively identical to the `main()` function explained in *Basic Forwarding Sample Application*.

The `lcore_main()` function is also identical.

The main difference is in the user defined `port_init()` function where the callbacks are added. This is explained in the next section:

### 6.3.2 The Port Initialization Function

The main functional part of the port initialization is shown below with comments:

```
static inline int
port_init(uint8_t port, struct rte_mempool *mbuf_pool)
{
    struct rte_eth_conf port_conf = port_conf_default;
    const uint16_t rx_rings = 1, tx_rings = 1;
    struct ether_addr addr;
    int retval;
    uint16_t q;

    if (port >= rte_eth_dev_count())
        return -1;

    /* Configure the Ethernet device. */
    retval = rte_eth_dev_configure(port, rx_rings, tx_rings, &port_conf);
    if (retval != 0)
        return retval;

    /* Allocate and set up 1 RX queue per Ethernet port. */
    for (q = 0; q < rx_rings; q++) {
        retval = rte_eth_rx_queue_setup(port, q, RX_RING_SIZE,
            rte_eth_dev_socket_id(port), NULL, mbuf_pool);
        if (retval < 0)
            return retval;
    }

    /* Allocate and set up 1 TX queue per Ethernet port. */
    for (q = 0; q < tx_rings; q++) {
        retval = rte_eth_tx_queue_setup(port, q, TX_RING_SIZE,
            rte_eth_dev_socket_id(port), NULL);
        if (retval < 0)
            return retval;
    }
}
```

```

        return retval;
    }

    /* Start the Ethernet port. */
    retval = rte_eth_dev_start(port);
    if (retval < 0)
        return retval;

    /* Enable RX in promiscuous mode for the Ethernet device. */
    rte_eth_promiscuous_enable(port);

    /* Add the callbacks for RX and TX.*/
    rte_eth_add_rx_callback(port, 0, add_timestamps, NULL);
    rte_eth_add_tx_callback(port, 0, calc_latency, NULL);

    return 0;
}

```

The RX and TX callbacks are added to the ports/queues as function pointers:

```

rte_eth_add_rx_callback(port, 0, add_timestamps, NULL);
rte_eth_add_tx_callback(port, 0, calc_latency, NULL);

```

More than one callback can be added and additional information can be passed to callback function pointers as a void\*. In the examples above NULL is used.

The add\_timestamps() and calc\_latency() functions are explained below.

### 6.3.3 The add\_timestamps() Callback

The add\_timestamps() callback is added to the RX port and is applied to all packets received:

```

static uint16_t
add_timestamps(uint8_t port __rte_unused, uint16_t qidx __rte_unused,
               struct rte_mbuf **pkts, uint16_t nb_pkts, void * __rte_unused)
{
    unsigned i;
    uint64_t now = rte_rdtsc();

    for (i = 0; i < nb_pkts; i++)
        pkts[i]->udata64 = now;

    return nb_pkts;
}

```

The DPDK function rte\_rdtsc() is used to add a cycle count timestamp to each packet (see the *cycles* section of the *DPDK API Documentation* for details).

### 6.3.4 The calc\_latency() Callback

The calc\_latency() callback is added to the TX port and is applied to all packets prior to transmission:

```

static uint16_t
calc_latency(uint8_t port __rte_unused, uint16_t qidx __rte_unused,
             struct rte_mbuf **pkts, uint16_t nb_pkts, void * __rte_unused)

```

```
{
    uint64_t cycles = 0;
    uint64_t now = rte_rdtsc();
    unsigned i;

    for (i = 0; i < nb_pkts; i++)
        cycles += now - pkts[i]->udata64;

    latency_numbers.total_cycles += cycles;
    latency_numbers.total_pkts += nb_pkts;

    if (latency_numbers.total_pkts > (100 * 1000 * 1000ULL)) {
        printf("Latency = %"PRIu64" cycles\n",
            latency_numbers.total_cycles / latency_numbers.total_pkts);

        latency_numbers.total_cycles = latency_numbers.total_pkts = 0;
    }

    return nb_pkts;
}
```

The `calc_latency()` function accumulates the total number of packets and the total number of cycles used. Once more than 100 million packets have been transmitted the average cycle count per packet is printed out and the counters are reset.

## IP FRAGMENTATION SAMPLE APPLICATION

The IPv4 Fragmentation application is a simple example of packet processing using the Data Plane Development Kit (DPDK). The application does L3 forwarding with IPv4 and IPv6 packet fragmentation.

### 7.1 Overview

The application demonstrates the use of zero-copy buffers for packet fragmentation. The initialization and run-time paths are very similar to those of the L2 forwarding application (see Chapter 9 “L2 Forwarding Simple Application (in Real and Virtualized Environments)” for more information). This guide highlights the differences between the two applications.

There are three key differences from the L2 Forwarding sample application:

- The first difference is that the IP Fragmentation sample application makes use of indirect buffers.
- The second difference is that the forwarding decision is taken based on information read from the input packet’s IP header.
- The third difference is that the application differentiates between IP and non-IP traffic by means of offload flags.

The Longest Prefix Match (LPM for IPv4, LPM6 for IPv6) table is used to store/lookup an outgoing port number, associated with that IP address. Any unmatched packets are forwarded to the originating port.

By default, input frame sizes up to 9.5 KB are supported. Before forwarding, the input IP packet is fragmented to fit into the “standard” Ethernet\* v2 MTU (1500 bytes).

### 7.2 Building the Application

To build the application:

1. Go to the sample application directory:

```
export RTE_SDK=/path/to/rte_sdk
cd ${RTE_SDK}/examples/ip_fragmentation
```

2. Set the target (a default target is used if not specified). For example:

```
export RTE_TARGET=x86_64-native-linuxapp-gcc
```

See the *DPDK Getting Started Guide* for possible RTE\_TARGET values.

1. Build the application:

```
make
```

## 7.3 Running the Application

The LPM object is created and loaded with the pre-configured entries read from global `l3fwd_ipv4_route_array` and `l3fwd_ipv6_route_array` tables. For each input packet, the packet forwarding decision (that is, the identification of the output interface for the packet) is taken as a result of LPM lookup. If the IP packet size is greater than default output MTU, then the input packet is fragmented and several fragments are sent via the output interface.

Application usage:

```
./build/ip_fragmentation [EAL options] -- -p PORTMASK [-q NQ]
```

where:

- -p PORTMASK is a hexadecimal bitmask of ports to configure
- -q NQ is the number of queue (=ports) per lcore (the default is 1)

To run the example in linuxapp environment with 2 lcores (2,4) over 2 ports(0,2) with 1 RX queue per lcore:

```
./build/ip_fragmentation -c 0x14 -n 3 -- -p 5
EAL: coremask set to 14
EAL: Detected lcore 0 on socket 0
EAL: Detected lcore 1 on socket 1
EAL: Detected lcore 2 on socket 0
EAL: Detected lcore 3 on socket 1
EAL: Detected lcore 4 on socket 0
...
Initializing port 0 on lcore 2... Address:00:1B:21:76:FA:2C, rxq=0 txq=2,0 txq=4,1
done: Link Up - speed 10000 Mbps - full-duplex
Skipping disabled port 1
Initializing port 2 on lcore 4... Address:00:1B:21:5C:FF:54, rxq=0 txq=2,0 txq=4,1
done: Link Up - speed 10000 Mbps - full-duplex
Skipping disabled port 3
IP_FRAG: Socket 0: adding route 100.10.0.0/16 (port 0)
IP_FRAG: Socket 0: adding route 100.20.0.0/16 (port 1)
...
IP_FRAG: Socket 0: adding route 0101:0101:0101:0101:0101:0101:0101:0101/48 (port 0)
IP_FRAG: Socket 0: adding route 0201:0101:0101:0101:0101:0101:0101:0101/48 (port 1)
...
IP_FRAG: entering main loop on lcore 4
IP_FRAG: -- lcoreid=4 portid=2
IP_FRAG: entering main loop on lcore 2
IP_FRAG: -- lcoreid=2 portid=0
```

To run the example in linuxapp environment with 1 lcore (4) over 2 ports(0,2) with 2 RX queues per lcore:

```
./build/ip_fragmentation -c 0x10 -n 3 -- -p 5 -q 2
```

To test the application, flows should be set up in the flow generator that match the values in the `l3fwd_ipv4_route_array` and/or `l3fwd_ipv6_route_array` table.

The default `l3fwd_ipv4_route_array` table is:

```
struct l3fwd_ipv4_route l3fwd_ipv4_route_array[] = {
    {IPv4(100, 10, 0, 0), 16, 0},
    {IPv4(100, 20, 0, 0), 16, 1},
    {IPv4(100, 30, 0, 0), 16, 2},
    {IPv4(100, 40, 0, 0), 16, 3},
    {IPv4(100, 50, 0, 0), 16, 4},
    {IPv4(100, 60, 0, 0), 16, 5},
    {IPv4(100, 70, 0, 0), 16, 6},
    {IPv4(100, 80, 0, 0), 16, 7},
};
```

The default `l3fwd_ipv6_route_array` table is:

```
struct l3fwd_ipv6_route l3fwd_ipv6_route_array[] = {
    {{1, 1, 1, 1, 1, 1, 1, 1, 1, 1, 1, 1, 1, 1, 1}, 48, 0},
    {{2, 1, 1, 1, 1, 1, 1, 1, 1, 1, 1, 1, 1, 1, 1}, 48, 1},
    {{3, 1, 1, 1, 1, 1, 1, 1, 1, 1, 1, 1, 1, 1, 1}, 48, 2},
    {{4, 1, 1, 1, 1, 1, 1, 1, 1, 1, 1, 1, 1, 1, 1}, 48, 3},
    {{5, 1, 1, 1, 1, 1, 1, 1, 1, 1, 1, 1, 1, 1, 1}, 48, 4},
    {{6, 1, 1, 1, 1, 1, 1, 1, 1, 1, 1, 1, 1, 1, 1}, 48, 5},
    {{7, 1, 1, 1, 1, 1, 1, 1, 1, 1, 1, 1, 1, 1, 1}, 48, 6},
    {{8, 1, 1, 1, 1, 1, 1, 1, 1, 1, 1, 1, 1, 1, 1}, 48, 7},
};
```

For example, for the input IPv4 packet with destination address: 100.10.1.1 and packet length 9198 bytes, seven IPv4 packets will be sent out from port #0 to the destination address 100.10.1.1: six of those packets will have length 1500 bytes and one packet will have length 318 bytes. IP Fragmentation sample application provides basic NUMA support in that all the memory structures are allocated on all sockets that have active lcores on them.

Refer to the *DPDK Getting Started Guide* for general information on running applications and the Environment Abstraction Layer (EAL) options.

## IPV4 MULTICAST SAMPLE APPLICATION

The IPv4 Multicast application is a simple example of packet processing using the Data Plane Development Kit (DPDK). The application performs L3 multicasting.

### 8.1 Overview

The application demonstrates the use of zero-copy buffers for packet forwarding. The initialization and run-time paths are very similar to those of the L2 forwarding application (see Chapter 9 “L2 Forwarding Sample Application (in Real and Virtualized Environments)” for details more information). This guide highlights the differences between the two applications. There are two key differences from the L2 Forwarding sample application:

- The IPv4 Multicast sample application makes use of indirect buffers.
- The forwarding decision is taken based on information read from the input packet’s IPv4 header.

The lookup method is the Four-byte Key (FBK) hash-based method. The lookup table is composed of pairs of destination IPv4 address (the FBK) and a port mask associated with that IPv4 address.

For convenience and simplicity, this sample application does not take IANA-assigned multicast addresses into account, but instead equates the last four bytes of the multicast group (that is, the last four bytes of the destination IP address) with the mask of ports to multicast packets to. Also, the application does not consider the Ethernet addresses; it looks only at the IPv4 destination address for any given packet.

### 8.2 Building the Application

To compile the application:

1. Go to the sample application directory:

```
export RTE_SDK=/path/to/rte_sdk
cd ${RTE_SDK}/examples/ipv4_multicast
```

2. Set the target (a default target is used if not specified). For example:

```
export RTE_TARGET=x86_64-native-linuxapp-gcc
```

See the *DPDK Getting Started Guide* for possible RTE\_TARGET values.

1. Build the application:

```
make
```

---

**Note:** The compiled application is written to the build subdirectory. To have the application written to a different location, the `O=/path/to/build/directory` option may be specified in the make command.

---

## 8.3 Running the Application

The application has a number of command line options:

```
./build/ipv4_multicast [EAL options] -- -p PORTMASK [-q NQ]
```

where,

- `-p PORTMASK`: Hexadecimal bitmask of ports to configure
- `-q NQ`: determines the number of queues per lcore

---

**Note:** Unlike the basic L2/L3 Forwarding sample applications, NUMA support is not provided in the IPv4 Multicast sample application.

---

Typically, to run the IPv4 Multicast sample application, issue the following command (as root):

```
./build/ipv4_multicast -c 0x00f -n 3 -- -p 0x3 -q 1
```

In this command:

- The `-c` option enables cores 0, 1, 2 and 3
- The `-n` option specifies 3 memory channels
- The `-p` option enables ports 0 and 1
- The `-q` option assigns 1 queue to each lcore

Refer to the *DPDK Getting Started Guide* for general information on running applications and the Environment Abstraction Layer (EAL) options.

## 8.4 Explanation

The following sections provide some explanation of the code. As mentioned in the overview section, the initialization and run-time paths are very similar to those of the L2 Forwarding sample application (see Chapter 9 “L2 Forwarding Sample Application in Real and Virtualized Environments” for more information). The following sections describe aspects that are specific to the IPv4 Multicast sample application.

### 8.4.1 Memory Pool Initialization

The IPv4 Multicast sample application uses three memory pools. Two of the pools are for indirect buffers used for packet duplication purposes. Memory pools for indirect buffers are



initialized differently from the memory pool for direct buffers:

```
packet_pool = rte_mempool_create("packet_pool", NB_PKT_MBUF, PKT_MBUF_SIZE, 32, sizeof(struct
    rte_pktmbuf_pool_init, NULL, rte_pktmbuf_init, NULL, rte_sock

header_pool = rte_mempool_create("header_pool", NB_HDR_MBUF, HDR_MBUF_SIZE, 32, 0, NULL, NULL,
clone_pool = rte_mempool_create("clone_pool", NB_CLONE_MBUF,
CLONE_MBUF_SIZE, 32, 0, NULL, NULL, rte_pktmbuf_init, NULL, rte_socket_id(), 0);
```

The reason for this is because indirect buffers are not supposed to hold any packet data and therefore can be initialized with lower amount of reserved memory for each buffer.

## 8.4.2 Hash Initialization

The hash object is created and loaded with the pre-configured entries read from a global array:

```
static int
init_mcast_hash(void)
{
    uint32_t i;
    mcast_hash_params.socket_id = rte_socket_id();

    mcast_hash = rte_fbk_hash_create(&mcast_hash_params);
    if (mcast_hash == NULL){
        return -1;
    }

    for (i = 0; i < N_MCAST_GROUPS; i++){
        if (rte_fbk_hash_add_key(mcast_hash, mcast_group_table[i].ip, mcast_group_table[i].port) != 0)
            return -1;
    }
    return 0;
}
```

## 8.4.3 Forwarding

All forwarding is done inside the `mcast_forward()` function. Firstly, the Ethernet\* header is removed from the packet and the IPv4 address is extracted from the IPv4 header:

```
/* Remove the Ethernet header from the input packet */
iphdr = (struct ipv4_hdr *)rte_pktmbuf_adj(m, sizeof(struct ether_hdr));
RTE_MBUF_ASSERT(iphdr != NULL);
dest_addr = rte_be_to_cpu_32(iphdr->dst_addr);
```

Then, the packet is checked to see if it has a multicast destination address and if the routing table has any ports assigned to the destination address:

```
if (!IS_IPV4_MCAST(dest_addr) ||
    (hash = rte_fbk_hash_lookup(mcast_hash, dest_addr)) <= 0 ||
    (port_mask = hash & enabled_port_mask) == 0) {
    rte_pktmbuf_free(m);
    return;
}
```

Then, the number of ports in the destination portmask is calculated with the help of the `bitcnt()` function:

```
/* Get number of bits set. */
static inline uint32_t bitcnt(uint32_t v)
{
    uint32_t n;

    for (n = 0; v != 0; v &= v - 1, n++)
        ;
    return (n);
}
```

This is done to determine which forwarding algorithm to use. This is explained in more detail in the next section.

Thereafter, a destination Ethernet address is constructed:

```
/* construct destination Ethernet address */
dst_eth_addr = ETHER_ADDR_FOR_IPV4_MCAST(dest_addr);
```

Since Ethernet addresses are also part of the multicast process, each outgoing packet carries the same destination Ethernet address. The destination Ethernet address is constructed from the lower 23 bits of the multicast group OR-ed with the Ethernet address 01:00:5e:00:00:00, as per RFC 1112:

```
#define ETHER_ADDR_FOR_IPV4_MCAST(x) \
    (rte_cpu_to_be_64(0x01005e000000ULL | ((x) & 0x7ffffff) >> 16))
```

Then, packets are dispatched to the destination ports according to the portmask associated with a multicast group:

```
for (port = 0; use_clone != port_mask; port_mask >>= 1, port++) {
    /* Prepare output packet and send it out. */

    if ((port_mask & 1) != 0) {
        if (likely ((mc = mcast_out_pkt(m, use_clone)) != NULL))
            mcast_send_pkt(mc, &dst_eth_addr.as_addr, qconf, port);
        else if (use_clone == 0)
            rte_pktmbuf_free(m);
    }
}
```

The actual packet transmission is done in the `mcast_send_pkt()` function:

```
static inline void mcast_send_pkt(struct rte_mbuf *pkt, struct ether_addr *dest_addr, struct l
{
    struct ether_hdr *ethdr;
    uint16_t len;

    /* Construct Ethernet header. */

    ethdr = (struct ether_hdr *)rte_pktmbuf_prepend(pkt, (uint16_t) sizeof(*ethdr));
    RTE_MBUF_ASSERT(ethdr != NULL);

    ether_addr_copy(dest_addr, &ethdr->d_addr);
    ether_addr_copy(&ports_eth_addr[port], &ethdr->s_addr);
    ethdr->ether_type = rte_be_to_cpu_16(ETHER_TYPE_IPv4);
}
```

```

    /* Put new packet into the output queue */

    len = qconf->tx_mbufs[port].len;
    qconf->tx_mbufs[port].m_table[len] = pkt;
    qconf->tx_mbufs[port].len = ++len;

    /* Transmit packets */

    if (unlikely(MAX_PKT_BURST == len))
        send_burst(qconf, port);
}

```

### 8.4.4 Buffer Cloning

This is the most important part of the application since it demonstrates the use of zero-copy buffer cloning. There are two approaches for creating the outgoing packet and although both are based on the data zero-copy idea, there are some differences in the detail.

The first approach creates a clone of the input packet, for example, walk through all segments of the input packet and for each of segment, create a new buffer and attach that new buffer to the segment (refer to `rte_pktmbuf_clone()` in the `rte_mbuf` library for more details). A new buffer is then allocated for the packet header and is prepended to the cloned buffer.

The second approach does not make a clone, it just increments the reference counter for all input packet segment, allocates a new buffer for the packet header and prepends it to the input packet.

Basically, the first approach reuses only the input packet's data, but creates its own copy of packet's metadata. The second approach reuses both input packet's data and metadata.

The advantage of first approach is that each outgoing packet has its own copy of the metadata, so we can safely modify the data pointer of the input packet. That allows us to skip creation if the output packet is for the last destination port and instead modify input packet's header in place. For example, for  $N$  destination ports, we need to invoke `mcast_out_pkt()` ( $N-1$ ) times.

The advantage of the second approach is that there is less work to be done for each outgoing packet, that is, the "clone" operation is skipped completely. However, there is a price to pay. The input packet's metadata must remain intact, so for  $N$  destination ports, we need to invoke `mcast_out_pkt()` ( $N$ ) times.

Therefore, for a small number of outgoing ports (and segments in the input packet), first approach is faster. As the number of outgoing ports (and/or input segments) grows, the second approach becomes more preferable.

Depending on the number of segments or the number of ports in the outgoing portmask, either the first (with cloning) or the second (without cloning) approach is taken:

```
use_clone = (port_num <= MCAST_CLONE_PORTS && m->pkt.nb_segs <= MCAST_CLONE_SEGS);
```

It is the `mcast_out_pkt()` function that performs the packet duplication (either with or without actually cloning the buffers):

```

static inline struct rte_mbuf *mcast_out_pkt(struct rte_mbuf *pkt, int use_clone)
{
    struct rte_mbuf *hdr;

```

```
/* Create new mbuf for the header. */  
  
if (unlikely ((hdr = rte_pktmbuf_alloc(header_pool)) == NULL))  
    return (NULL);  
  
/* If requested, then make a new clone packet. */  
  
if (use_clone != 0 && unlikely ((pkt = rte_pktmbuf_clone(pkt, clone_pool)) == NULL)) {  
    rte_pktmbuf_free(hdr);  
    return (NULL);  
}  
  
/* prepend new header */  
  
hdr->pkt.next = pkt;  
  
/* update header's fields */  
  
hdr->pkt.pkt_len = (uint16_t)(hdr->pkt.data_len + pkt->pkt.pkt_len);  
hdr->pkt.nb_segs = (uint8_t)(pkt->pkt.nb_segs + 1);  
  
/* copy metadata from source packet */  
  
hdr->pkt.in_port = pkt->pkt.in_port;  
hdr->pkt.vlan_macip = pkt->pkt.vlan_macip;  
hdr->pkt.hash = pkt->pkt.hash;  
hdr->ol_flags = pkt->ol_flags;  
rte_mbuf_sanity_check(hdr, RTE_MBUF_PKT, 1);  
  
return (hdr);  
}
```

---

## IP REASSEMBLY SAMPLE APPLICATION

The L3 Forwarding application is a simple example of packet processing using the DPDK. The application performs L3 forwarding with reassembly for fragmented IPv4 and IPv6 packets.

### 9.1 Overview

The application demonstrates the use of the DPDK libraries to implement packet forwarding with reassembly for IPv4 and IPv6 fragmented packets. The initialization and run-time paths are very similar to those of the L2 forwarding application (see Chapter 9 “L2 Forwarding Sample Application” for more information). The main difference from the L2 Forwarding sample application is that it reassembles fragmented IPv4 and IPv6 packets before forwarding. The maximum allowed size of reassembled packet is 9.5 KB.

There are two key differences from the L2 Forwarding sample application:

- The first difference is that the forwarding decision is taken based on information read from the input packet’s IP header.
- The second difference is that the application differentiates between IP and non-IP traffic by means of offload flags.

### 9.2 The Longest Prefix Match (LPM for IPv4, LPM6 for IPv6) table is used to store/lookup an outgoing port number, associated with that IPv4 address. Any unmatched packets are forwarded to the originating port.

#### Compiling the Application

To compile the application:

1. Go to the sample application directory:

```
export RTE_SDK=/path/to/rte_sdk
cd ${RTE_SDK}/examples/ip_reassembly
```

1. Set the target (a default target is used if not specified). For example:

```
export RTE_TARGET=x86_64-native-linuxapp-gcc
```

See the *DPDK Getting Started Guide* for possible RTE\_TARGET values.

1. Build the application:

```
make
```

## 9.3 Running the Application

The application has a number of command line options:

```
./build/ip_reassembly [EAL options] -- -p PORTMASK [-q NQ] [--maxflows=FLAWS>] [--flowttl=TTL]
```

where:

- -p PORTMASK: Hexadecimal bitmask of ports to configure
- -q NQ: Number of RX queues per lcore
- --maxflows=FLAWS: determines maximum number of active fragmented flows (1-65535). Default value: 4096.
- --flowttl=TTL[(s|ms)]: determines maximum Time To Live for fragmented packet. If all fragments of the packet wouldn't appear within given time-out, then they are considered as invalid and will be dropped. Valid range is 1ms - 3600s. Default value: 1s.

To run the example in linuxapp environment with 2 lcores (2,4) over 2 ports(0,2) with 1 RX queue per lcore:

```
./build/ip_reassembly -c 0x14 -n 3 -- -p 5
EAL: coremask set to 14
EAL: Detected lcore 0 on socket 0
EAL: Detected lcore 1 on socket 1
EAL: Detected lcore 2 on socket 0
EAL: Detected lcore 3 on socket 1
EAL: Detected lcore 4 on socket 0
...

Initializing port 0 on lcore 2... Address:00:1B:21:76:FA:2C, rxq=0 txq=2,0 txq=4,1
done: Link Up - speed 10000 Mbps - full-duplex
Skipping disabled port 1
Initializing port 2 on lcore 4... Address:00:1B:21:5C:FF:54, rxq=0 txq=2,0 txq=4,1
done: Link Up - speed 10000 Mbps - full-duplex
Skipping disabled port 3
IP_FRAG: Socket 0: adding route 100.10.0.0/16 (port 0)
IP_RSMBL: Socket 0: adding route 100.20.0.0/16 (port 1)
...

IP_RSMBL: Socket 0: adding route 0101:0101:0101:0101:0101:0101:0101:0101/48 (port 0)
IP_RSMBL: Socket 0: adding route 0201:0101:0101:0101:0101:0101:0101:0101/48 (port 1)
...

IP_RSMBL: entering main loop on lcore 4
IP_RSMBL: -- lcoreid=4 portid=2
IP_RSMBL: entering main loop on lcore 2
IP_RSMBL: -- lcoreid=2 portid=0
```

To run the example in linuxapp environment with 1 lcore (4) over 2 ports(0,2) with 2 RX queues per lcore:

```
./build/ip_reassembly -c 0x10 -n 3 -- -p 5 -q 2
```

To test the application, flows should be set up in the flow generator that match the values in the `l3fwd_ipv4_route_array` and/or `l3fwd_ipv6_route_array` table.

Please note that in order to test this application, the traffic generator should be generating valid fragmented IP packets. For IPv6, the only supported case is when no other extension headers other than fragment extension header are present in the packet.

The default `l3fwd_ipv4_route_array` table is:

```
struct l3fwd_ipv4_route l3fwd_ipv4_route_array[] = {
    {IPv4(100, 10, 0, 0), 16, 0},
    {IPv4(100, 20, 0, 0), 16, 1},
    {IPv4(100, 30, 0, 0), 16, 2},
    {IPv4(100, 40, 0, 0), 16, 3},
    {IPv4(100, 50, 0, 0), 16, 4},
    {IPv4(100, 60, 0, 0), 16, 5},
    {IPv4(100, 70, 0, 0), 16, 6},
    {IPv4(100, 80, 0, 0), 16, 7},
};
```

The default `l3fwd_ipv6_route_array` table is:

```
struct l3fwd_ipv6_route l3fwd_ipv6_route_array[] = {
    {{1, 1, 1, 1, 1, 1, 1, 1, 1, 1, 1, 1, 1, 1, 1}, 48, 0},
    {{2, 1, 1, 1, 1, 1, 1, 1, 1, 1, 1, 1, 1, 1, 1}, 48, 1},
    {{3, 1, 1, 1, 1, 1, 1, 1, 1, 1, 1, 1, 1, 1, 1}, 48, 2},
    {{4, 1, 1, 1, 1, 1, 1, 1, 1, 1, 1, 1, 1, 1, 1}, 48, 3},
    {{5, 1, 1, 1, 1, 1, 1, 1, 1, 1, 1, 1, 1, 1, 1}, 48, 4},
    {{6, 1, 1, 1, 1, 1, 1, 1, 1, 1, 1, 1, 1, 1, 1}, 48, 5},
    {{7, 1, 1, 1, 1, 1, 1, 1, 1, 1, 1, 1, 1, 1, 1}, 48, 6},
    {{8, 1, 1, 1, 1, 1, 1, 1, 1, 1, 1, 1, 1, 1, 1}, 48, 7},
};
```

For example, for the fragmented input IPv4 packet with destination address: 100.10.1.1, a reassembled IPv4 packet be sent out from port #0 to the destination address 100.10.1.1 once all the fragments are collected.

## 9.4 Explanation

The following sections provide some explanation of the sample application code. As mentioned in the overview section, the initialization and run-time paths are very similar to those of the L2 forwarding application (see Chapter 9 “L2 Forwarding Sample Application” for more information). The following sections describe aspects that are specific to the IP reassemble sample application.

### 9.4.1 IPv4 Fragment Table Initialization

This application uses the `rte_ip_frag` library. Please refer to Programmer’s Guide for more detailed explanation of how to use this library. Fragment table maintains information about already received fragments of the packet. Each IP packet is uniquely identified by triple `<Source IP address>`, `<Destination IP address>`, `<ID>`. To avoid lock contention, each RX queue has its own Fragment Table, e.g. the application can’t handle the situation when different fragments of the same packet arrive through different RX queues. Each table entry can hold information about packet consisting of up to `RTE_LIBRTE_IP_FRAG_MAX_FRAGS` fragments.

```

frag_cycles = (rte_get_tsc_hz() + MS_PER_S - 1) / MS_PER_S * max_flow_ttl;

if ((qconf->frag_tbl[queue] = rte_ip_frag_tbl_create(max_flow_num, IPV4_FRAG_TBL_BUCKET_ENTRIES,
{
    RTE_LOG(ERR, IP_RSMBL, "ip_frag_tbl_create(%u) on " "lcore: %u for queue: %u failed\n", m
    return -1;
}

```

## 9.4.2 Mempools Initialization

The reassembly application demands a lot of mbuf's to be allocated. At any given time up to  $(2 * \text{max\_flow\_num} * \text{RTE\_LIBRTE\_IP\_FRAG\_MAX\_FRAGS} * \text{<maximum number of mbufs per packet>})$  can be stored inside Fragment Table waiting for remaining fragments. To keep mempool size under reasonable limits and to avoid situation when one RX queue can starve other queues, each RX queue uses its own mempool.

```

nb_mbuf = RTE_MAX(max_flow_num, 2UL * MAX_PKT_BURST) * RTE_LIBRTE_IP_FRAG_MAX_FRAGS;
nb_mbuf *= (port_conf.rxmode.max_rx_pkt_len + BUF_SIZE - 1) / BUF_SIZE;
nb_mbuf *= 2; /* ipv4 and ipv6 */
nb_mbuf += RTE_TEST_RX_DESC_DEFAULT + RTE_TEST_TX_DESC_DEFAULT;
nb_mbuf = RTE_MAX(nb_mbuf, (uint32_t)NB_MBUF);

rte_sprintf(buf, sizeof(buf), "mbuf_pool_%u_%u", lcore, queue);

if ((rxq->pool = rte_mempool_create(buf, nb_mbuf, MBUF_SIZE, 0, sizeof(struct rte_pktmbuf_pool)
    rte_pktmbuf_init, NULL, socket, MEMPOOL_F_SP_PUT | MEMPOOL_F_SC_GET)) == NULL) {

    RTE_LOG(ERR, IP_RSMBL, "mempool_create(%s) failed", buf);
    return -1;
}

```

## 9.4.3 Packet Reassembly and Forwarding

For each input packet, the packet forwarding operation is done by the `l3fwd_simple_forward()` function. If the packet is an IPv4 or IPv6 fragment, then it calls `rte_ipv4_reassemble_packet()` for IPv4 packets, or `rte_ipv6_reassemble_packet()` for IPv6 packets. These functions either return a pointer to valid mbuf that contains reassembled packet, or NULL (if the packet can't be reassembled for some reason). Then `l3fwd_simple_forward()` continues with the code for the packet forwarding decision (that is, the identification of the output interface for the packet) and actual transmit of the packet.

The `rte_ipv4_reassemble_packet()` or `rte_ipv6_reassemble_packet()` are responsible for:

1. Searching the Fragment Table for entry with packet's <IP Source Address, IP Destination Address, Packet ID>
2. If the entry is found, then check if that entry already timed-out. If yes, then free all previously received fragments, and remove information about them from the entry.
3. If no entry with such key is found, then try to create a new one by one of two ways:
  - (a) Use as empty entry
  - (b) Delete a timed-out entry, free mbufs associated with it mbufs and store a new entry with specified key in it.



4. Update the entry with new fragment information and check if a packet can be reassembled (the packet's entry contains all fragments).
  - (a) If yes, then, reassemble the packet, mark table's entry as empty and return the reassembled mbuf to the caller.
  - (b) If no, then just return a NULL to the caller.

If at any stage of packet processing a reassembly function encounters an error (can't insert new entry into the Fragment table, or invalid/timed-out fragment), then it will free all associated with the packet fragments, mark the table entry as invalid and return NULL to the caller.

#### 9.4.4 Debug logging and Statistics Collection

The `RTE_LIBRTE_IP_FRAG_TBL_STAT` controls statistics collection for the IP Fragment Table. This macro is disabled by default. To make `ip_reassembly` print the statistics to the standard output, the user must send either an `USR1`, `INT` or `TERM` signal to the process. For all of these signals, the `ip_reassembly` process prints Fragment table statistics for each RX queue, plus the `INT` and `TERM` will cause process termination as usual.

## **KERNEL NIC INTERFACE SAMPLE APPLICATION**

The Kernel NIC Interface (KNI) is a DPDK control plane solution that allows userspace applications to exchange packets with the kernel networking stack. To accomplish this, DPDK userspace applications use an IOCTL call to request the creation of a KNI virtual device in the Linux\* kernel. The IOCTL call provides interface information and the DPDK's physical address space, which is re-mapped into the kernel address space by the KNI kernel loadable module that saves the information to a virtual device context. The DPDK creates FIFO queues for packet ingress and egress to the kernel module for each device allocated.

The KNI kernel loadable module is a standard net driver, which upon receiving the IOCTL call access the DPDK's FIFO queue to receive/transmit packets from/to the DPDK userspace application. The FIFO queues contain pointers to data packets in the DPDK. This:

- Provides a faster mechanism to interface with the kernel net stack and eliminates system calls
- Facilitates the DPDK using standard Linux\* userspace net tools (tcpdump, ftp, and so on)
- Eliminate the copy\_to\_user and copy\_from\_user operations on packets.

The Kernel NIC Interface sample application is a simple example that demonstrates the use of the DPDK to create a path for packets to go through the Linux\* kernel. This is done by creating one or more kernel net devices for each of the DPDK ports. The application allows the use of standard Linux tools (ethtool, ifconfig, tcpdump) with the DPDK ports and also the exchange of packets between the DPDK application and the Linux\* kernel.

### **10.1 Overview**

The Kernel NIC Interface sample application uses two threads in user space for each physical NIC port being used, and allocates one or more KNI device for each physical NIC port with kernel module's support. For a physical NIC port, one thread reads from the port and writes to KNI devices, and another thread reads from KNI devices and writes the data unmodified to the physical NIC port. It is recommended to configure one KNI device for each physical NIC port. If configured with more than one KNI devices for a physical NIC port, it is just for performance testing, or it can work together with VMDq support in future.

The packet flow through the Kernel NIC Interface application is as shown in the following figure.

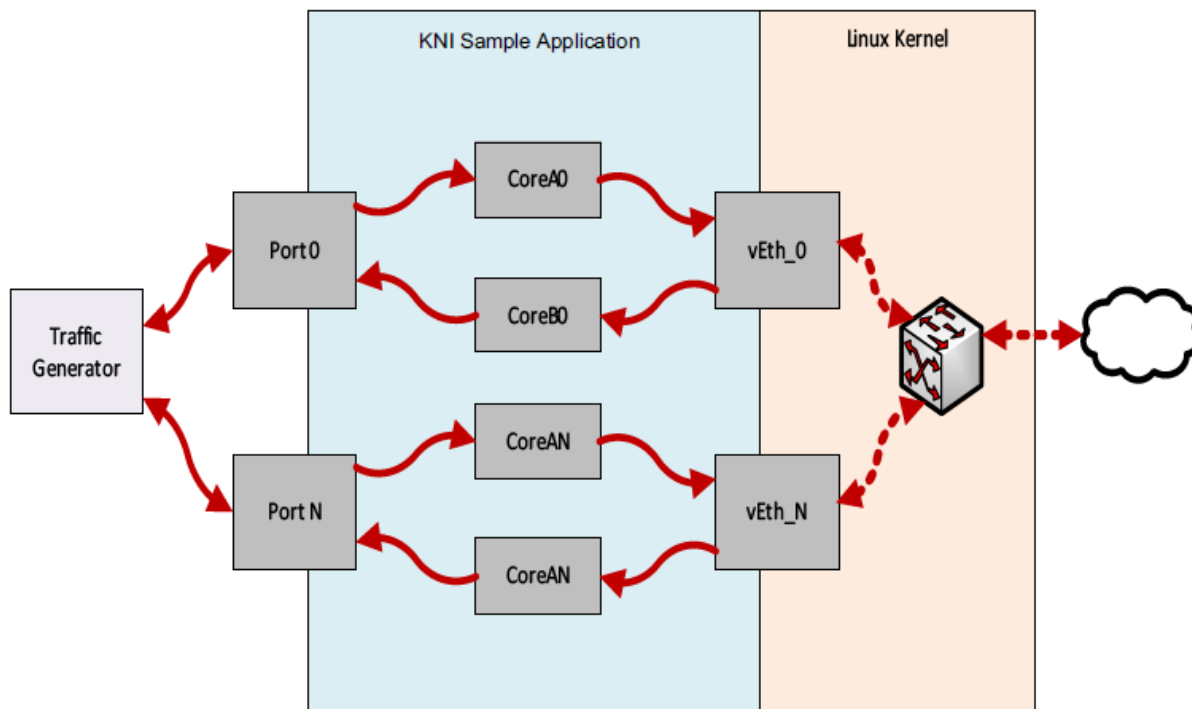

Figure 10.1: Kernel NIC Application Packet Flow

## 10.2 Compiling the Application

Compile the application as follows:

1. Go to the example directory:

```
export RTE_SDK=/path/to/rte_sdk cd
${RTE_SDK}/examples/kni
```

2. Set the target (a default target is used if not specified)

**Note:** This application is intended as a linuxapp only.

```
export RTE_TARGET=x86_64-native-linuxapp-gcc
```

3. Build the application:

```
make
```

## 10.3 Loading the Kernel Module

Loading the KNI kernel module without any parameter is the typical way a DPDK application gets packets into and out of the kernel net stack. This way, only one kernel thread is created for all KNI devices for packet receiving in kernel side:

```
#insmod rte_kni.ko
```

Pinning the kernel thread to a specific core can be done using a taskset command such as following:

```
#taskset -p 100000 pgrep --fl kni_thread | awk '{print $1}'
```

This command line tries to pin the specific kni\_thread on the 20th lcore (lcore numbering starts at 0), which means it needs to check if that lcore is available on the board. This command must be sent after the application has been launched, as insmod does not start the kni thread.

For optimum performance, the lcore in the mask must be selected to be on the same socket as the lcores used in the KNI application.

To provide flexibility of performance, the kernel module of the KNI, located in the kmod sub-directory of the DPDK target directory, can be loaded with parameter of kthread\_mode as follows:

- #insmod rte\_kni.ko kthread\_mode=single

This mode will create only one kernel thread for all KNI devices for packet receiving in kernel side. By default, it is in this single kernel thread mode. It can set core affinity for this kernel thread by using Linux command taskset.

- #insmod rte\_kni.ko kthread\_mode =multiple

This mode will create a kernel thread for each KNI device for packet receiving in kernel side. The core affinity of each kernel thread is set when creating the KNI device. The lcore ID for each kernel thread is provided in the command line of launching the application. Multiple kernel thread mode can provide scalable higher performance.

To measure the throughput in a loopback mode, the kernel module of the KNI, located in the kmod sub-directory of the DPDK target directory, can be loaded with parameters as follows:

- #insmod rte\_kni.ko lo\_mode=lo\_mode\_fifo

This loopback mode will involve ring enqueue/dequeue operations in kernel space.

- #insmod rte\_kni.ko lo\_mode=lo\_mode\_fifo\_skb

This loopback mode will involve ring enqueue/dequeue operations and sk buffer copies in kernel space.

## 10.4 Running the Application

The application requires a number of command line options:

```
kni [EAL options] -- -P -p PORTMASK --config="(port,lcore_rx,lcore_tx[,lcore_kthread,...]),[,port,lcore_rx,lcore_tx[,lcore_kthread,...]]"
```

Where:

- -P: Set all ports to promiscuous mode so that packets are accepted regardless of the packet's Ethernet MAC destination address. Without this option, only packets with the Ethernet MAC destination address set to the Ethernet address of the port are accepted.
- -p PORTMASK: Hexadecimal bitmask of ports to configure.
- --config="(port,lcore\_rx, lcore\_tx[,lcore\_kthread, ...]) [, port,lcore\_rx, lcore\_tx[,lcore\_kthread, ...]]": Determines which lcores of RX, TX, kernel thread are mapped to which ports.

Refer to *DPDK Getting Started Guide* for general information on running applications and the Environment Abstraction Layer (EAL) options.

The `-c` `coremask` parameter of the EAL options should include the lcores indicated by the `lcore_rx` and `lcore_tx`, but does not need to include lcores indicated by `lcore_kthread` as they are used to pin the kernel thread on. The `-p` `PORTMASK` parameter should include the ports indicated by the port in `--config`, neither more nor less.

The `lcore_kthread` in `--config` can be configured none, one or more lcore IDs. In multiple kernel thread mode, if configured none, a KNI device will be allocated for each port, while no specific lcore affinity will be set for its kernel thread. If configured one or more lcore IDs, one or more KNI devices will be allocated for each port, while specific lcore affinity will be set for its kernel thread. In single kernel thread mode, if configured none, a KNI device will be allocated for each port. If configured one or more lcore IDs, one or more KNI devices will be allocated for each port while no lcore affinity will be set as there is only one kernel thread for all KNI devices.

For example, to run the application with two ports served by six lcores, one lcore of RX, one lcore of TX, and one lcore of kernel thread for each port:

```
./build/kni -c 0xf0 -n 4 -- -P -p 0x3 -config="(0,4,6,8),(1,5,7,9)"
```

## 10.5 KNI Operations

Once the KNI application is started, one can use different Linux\* commands to manage the net interfaces. If more than one KNI devices configured for a physical port, only the first KNI device will be paired to the physical device. Operations on other KNI devices will not affect the physical port handled in user space application.

Assigning an IP address:

```
#ifconfig vEth0_0 192.168.0.1
```

Displaying the NIC registers:

```
#ethtool -d vEth0_0
```

Dumping the network traffic:

```
#tcpdump -i vEth0_0
```

When the DPDK userspace application is closed, all the KNI devices are deleted from Linux\*.

## 10.6 Explanation

The following sections provide some explanation of code.

### 10.6.1 Initialization

Setup of mbuf pool, driver and queues is similar to the setup done in the L2 Forwarding sample application (see Chapter 9 “L2 Forwarding Sample Application (in Real and Virtualized Environments)” for details). In addition, one or more kernel NIC interfaces are allocated for each of the configured ports according to the command line parameters.

The code for creating the kernel NIC interface for a specific port is as follows:

```
kni = rte_kni_create(port, MAX_PACKET_SZ, pktmbuf_pool, &kni_ops);
if (kni == NULL)
    rte_exit(EXIT_FAILURE, "Fail to create kni dev "
              "for port: %d\n", port);
```

The code for allocating the kernel NIC interfaces for a specific port is as follows:

```
static int
kni_alloc(uint8_t port_id)
{
    uint8_t i;
    struct rte_kni *kni;
    struct rte_kni_conf conf;
    struct kni_port_params **params = kni_port_params_array;

    if (port_id >= RTE_MAX_ETHPORTS || !params[port_id])
        return -1;

    params[port_id]->nb_kni = params[port_id]->nb_lcore_k ? params[port_id]->nb_lcore_k : 1;

    for (i = 0; i < params[port_id]->nb_kni; i++) {
        /* Clear conf at first */

        memset(&conf, 0, sizeof(conf));
        if (params[port_id]->nb_lcore_k) {
            rte_sprintf(conf.name, RTE_KNI_NAMESIZE, "vEth%u_%u", port_id, i);
            conf.core_id = params[port_id]->lcore_k[i];
            conf.force_bind = 1;
        } else
            rte_sprintf(conf.name, RTE_KNI_NAMESIZE, "vEth%u", port_id);
        conf.group_id = (uint16_t)port_id;
        conf.mbuf_size = MAX_PACKET_SZ;

        /*
         * The first KNI device associated to a port
         * is the master, for multiple kernel thread
         * environment.
         */

        if (i == 0) {
            struct rte_kni_ops ops;
            struct rte_eth_dev_info dev_info;

            memset(&dev_info, 0, sizeof(dev_info));
            rte_eth_dev_info_get(port_id, &dev_info);

            conf.addr = dev_info.pci_dev->addr;
            conf.id = dev_info.pci_dev->id;

            memset(&ops, 0, sizeof(ops));

            ops.port_id = port_id;
            ops.change_mtu = kni_change_mtu;
            ops.config_network_if = kni_config_network_interface;

            kni = rte_kni_alloc(pktmbuf_pool, &conf, &ops);
        } else
            kni = rte_kni_alloc(pktmbuf_pool, &conf, NULL);

        if (!kni)
            rte_exit(EXIT_FAILURE, "Fail to create kni for "
                    "port %d, core %d\n", port_id, i);
    }
}
```

```

        "port: %d\n", port_id);

        params[port_id]->kni[i] = kni;
    }
    return 0;
}

```

The other step in the initialization process that is unique to this sample application is the association of each port with lcores for RX, TX and kernel threads.

- One lcore to read from the port and write to the associated one or more KNI devices
- Another lcore to read from one or more KNI devices and write to the port
- Other lcores for pinning the kernel threads on one by one

This is done by using the 'kni\_port\_params\_array[]' array, which is indexed by the port ID. The code is as follows:

```

static int
parse_config(const char *arg)
{
    const char *p, *p0 = arg;
    char s[256], *end;
    unsigned size;
    enum fieldnames {
        FLD_PORT = 0,
        FLD_LCORE_RX,
        FLD_LCORE_TX,
        _NUM_FLD = KNI_MAX_KTHREAD + 3,
    };
    int i, j, nb_token;
    char *str_fld[_NUM_FLD];
    unsigned long int_fld[_NUM_FLD];
    uint8_t port_id, nb_kni_port_params = 0;

    memset(&kni_port_params_array, 0, sizeof(kni_port_params_array));

    while (((p = strchr(p0, '(')) != NULL) && nb_kni_port_params < RTE_MAX_ETHPORTS) {
        p++;
        if ((p0 = strchr(p, ')')) == NULL)
            goto fail;

        size = p0 - p;

        if (size >= sizeof(s)) {
            printf("Invalid config parameters\n");
            goto fail;
        }

        rte_sprintf(s, sizeof(s), "%.*s", size, p);
        nb_token = rte_strsplit(s, sizeof(s), str_fld, _NUM_FLD, ',');

        if (nb_token <= FLD_LCORE_TX) {
            printf("Invalid config parameters\n");
            goto fail;
        }

        for (i = 0; i < nb_token; i++) {
            errno = 0;
            int_fld[i] = strtoul(str_fld[i], &end, 0);
            if (errno != 0 || end == str_fld[i]) {
                printf("Invalid config parameters\n");
            }
        }
    }
}

```

```

        goto fail;
    }
}

i = 0;
port_id = (uint8_t)int_fld[i++];

if (port_id >= RTE_MAX_ETHPORTS) {
    printf("Port ID %u could not exceed the maximum %u\n", port_id, RTE_MAX_ETHPORTS);
    goto fail;
}

if (kni_port_params_array[port_id]) {
    printf("Port %u has been configured\n", port_id);
    goto fail;
}

kni_port_params_array[port_id] = (struct kni_port_params*)rte_zmalloc("KNI_port_params",
    sizeof(struct kni_port_params), 0);
kni_port_params_array[port_id]->port_id = port_id;
kni_port_params_array[port_id]->lcore_rx = (uint8_t)int_fld[i++];
kni_port_params_array[port_id]->lcore_tx = (uint8_t)int_fld[i++];

if (kni_port_params_array[port_id]->lcore_rx >= RTE_MAX_LCORE || kni_port_params_array[port_id]->lcore_tx >= RTE_MAX_LCORE) {
    printf("lcore_rx %u or lcore_tx %u ID could not "
        "exceed the maximum %u\n",
        kni_port_params_array[port_id]->lcore_rx, kni_port_params_array[port_id]->lcore_tx, RTE_MAX_LCORE);
    goto fail;
}

for (j = 0; i < nb_token && j < KNI_MAX_KTHREAD; i++, j++)
    kni_port_params_array[port_id]->lcore_k[j] = (uint8_t)int_fld[i];
kni_port_params_array[port_id]->nb_lcore_k = j;
}

print_config();

return 0;

fail:

for (i = 0; i < RTE_MAX_ETHPORTS; i++) {
    if (kni_port_params_array[i]) {
        rte_free(kni_port_params_array[i]);
        kni_port_params_array[i] = NULL;
    }
}

return -1;
}

```

## 10.6.2 Packet Forwarding

After the initialization steps are completed, the `main_loop()` function is run on each lcore. This function first checks the `lcore_id` against the user provided `lcore_rx` and `lcore_tx` to see if this lcore is reading from or writing to kernel NIC interfaces.

For the case that reads from a NIC port and writes to the kernel NIC interfaces, the packet reception is the same as in L2 Forwarding sample application (see Section [Receive, Process and Transmit Packets](#)). The packet transmission is done by sending mbufs into the kernel NIC



interfaces by `rte_kni_tx_burst()`. The KNI library automatically frees the mbufs after the kernel successfully copied the mbufs.

```

/**
 * Interface to burst rx and enqueue mbufs into rx_q
 */

static void
kni_ingress(struct kni_port_params *p)
{
    uint8_t i, nb_kni, port_id;
    unsigned nb_rx, num;
    struct rte_mbuf *pkts_burst[PKT_BURST_SZ];

    if (p == NULL)
        return;

    nb_kni = p->nb_kni;
    port_id = p->port_id;

    for (i = 0; i < nb_kni; i++) {
        /* Burst rx from eth */
        nb_rx = rte_eth_rx_burst(port_id, 0, pkts_burst, PKT_BURST_SZ);
        if (unlikely(nb_rx > PKT_BURST_SZ)) {
            RTE_LOG(ERR, APP, "Error receiving from eth\n");
            return;
        }

        /* Burst tx to kni */
        num = rte_kni_tx_burst(p->kni[i], pkts_burst, nb_rx);
        kni_stats[port_id].rx_packets += num;
        rte_kni_handle_request(p->kni[i]);

        if (unlikely(num < nb_rx)) {
            /* Free mbufs not tx to kni interface */
            kni_burst_free_mbufs(&pkts_burst[num], nb_rx - num);
            kni_stats[port_id].rx_dropped += nb_rx - num;
        }
    }
}

```

For the other case that reads from kernel NIC interfaces and writes to a physical NIC port, packets are retrieved by reading mbufs from kernel NIC interfaces by `rte_kni_rx_burst()`. The packet transmission is the same as in the L2 Forwarding sample application (see Section *Receive, Process and Transmit Packets*).

```

/**
 * Interface to dequeue mbufs from tx_q and burst tx
 */

static void
kni_egress(struct kni_port_params *p)
{
    uint8_t i, nb_kni, port_id;
    unsigned nb_tx, num;
    struct rte_mbuf *pkts_burst[PKT_BURST_SZ];

    if (p == NULL)
        return;

    nb_kni = p->nb_kni;

```

```

port_id = p->port_id;

for (i = 0; i < nb_kni; i++) {
    /* Burst rx from kni */
    num = rte_kni_rx_burst(p->kni[i], pkts_burst, PKT_BURST_SZ);
    if (unlikely(num > PKT_BURST_SZ)) {
        RTE_LOG(ERR, APP, "Error receiving from KNI\n");
        return;
    }

    /* Burst tx to eth */

    nb_tx = rte_eth_tx_burst(port_id, 0, pkts_burst, (uint16_t)num);

    kni_stats[port_id].tx_packets += nb_tx;

    if (unlikely(nb_tx < num)) {
        /* Free mbufs not tx to NIC */
        kni_burst_free_mbufs(&pkts_burst[nb_tx], num - nb_tx);
        kni_stats[port_id].tx_dropped += num - nb_tx;
    }
}
}

```

### 10.6.3 Callbacks for Kernel Requests

To execute specific PMD operations in user space requested by some Linux\* commands, callbacks must be implemented and filled in the struct `rte_kni_ops` structure. Currently, setting a new MTU and configuring the network interface (up/down) are supported.

```

static struct rte_kni_ops kni_ops = {
    .change_mtu = kni_change_mtu,
    .config_network_if = kni_config_network_interface,
};

/* Callback for request of changing MTU */

static int
kni_change_mtu(uint8_t port_id, unsigned new_mtu)
{
    int ret;
    struct rte_eth_conf conf;

    if (port_id >= rte_eth_dev_count()) {
        RTE_LOG(ERR, APP, "Invalid port id %d\n", port_id);
        return -EINVAL;
    }

    RTE_LOG(INFO, APP, "Change MTU of port %d to %u\n", port_id, new_mtu);

    /* Stop specific port */

    rte_eth_dev_stop(port_id);

    memcpy(&conf, &port_conf, sizeof(conf));

    /* Set new MTU */

    if (new_mtu > ETHER_MAX_LEN)
        conf.rxmode.jumbo_frame = 1;
    else

```

```

        conf.rxmode.jumbo_frame = 0;

        /* mtu + length of header + length of FCS = max pkt length */
        conf.rxmode.max_rx_pkt_len = new_mtu + KNI_ENET_HEADER_SIZE + KNI_ENET_FCS_SIZE;

        ret = rte_eth_dev_configure(port_id, 1, 1, &conf);
        if (ret < 0) {
            RTE_LOG(ERR, APP, "Fail to reconfigure port %d\n", port_id);
            return ret;
        }

        /* Restart specific port */

        ret = rte_eth_dev_start(port_id);
        if (ret < 0) {
            RTE_LOG(ERR, APP, "Fail to restart port %d\n", port_id);
            return ret;
        }

        return 0;
    }

    /* Callback for request of configuring network interface up/down */
    static int
    kni_config_network_interface(uint8_t port_id, uint8_t if_up)
    {
        int ret = 0;

        if (port_id >= rte_eth_dev_count() || port_id >= RTE_MAX_ETHPORTS) {
            RTE_LOG(ERR, APP, "Invalid port id %d\n", port_id);
            return -EINVAL;
        }

        RTE_LOG(INFO, APP, "Configure network interface of %d %s\n",
            port_id, if_up ? "up" : "down");

        if (if_up != 0) {
            /* Configure network interface up */
            rte_eth_dev_stop(port_id);
            ret = rte_eth_dev_start(port_id);
        } else /* Configure network interface down */
            rte_eth_dev_stop(port_id);

        if (ret < 0)
            RTE_LOG(ERR, APP, "Failed to start port %d\n", port_id);
        return ret;
    }
}

```

## L2 FORWARDING SAMPLE APPLICATION (IN REAL AND VIRTUALIZED ENVIRONMENTS) WITH CORE LOAD STATISTICS.

The L2 Forwarding sample application is a simple example of packet processing using the Data Plane Development Kit (DPDK) which also takes advantage of Single Root I/O Virtualization (SR-IOV) features in a virtualized environment.

---

**Note:** This application is a variation of L2 Forwarding sample application. It demonstrate possible scheme of job stats library usage therefore some parts of this document is identical with original L2 forwarding application.

---

### 11.1 Overview

The L2 Forwarding sample application, which can operate in real and virtualized environments, performs L2 forwarding for each packet that is received. The destination port is the adjacent port from the enabled portmask, that is, if the first four ports are enabled (portmask 0xf), ports 1 and 2 forward into each other, and ports 3 and 4 forward into each other. Also, the MAC addresses are affected as follows:

- The source MAC address is replaced by the TX port MAC address
- The destination MAC address is replaced by 02:00:00:00:00:TX\_PORT\_ID

This application can be used to benchmark performance using a traffic-generator, as shown in the Fig. 11.1.

The application can also be used in a virtualized environment as shown in Fig. 11.2.

The L2 Forwarding application can also be used as a starting point for developing a new application based on the DPDK.

#### 11.1.1 Virtual Function Setup Instructions

This application can use the virtual function available in the system and therefore can be used in a virtual machine without passing through the whole Network Device into a guest machine in a virtualized scenario. The virtual functions can be enabled in the host machine or the hypervisor with the respective physical function driver.

For example, in a Linux\* host machine, it is possible to enable a virtual function using the following command:

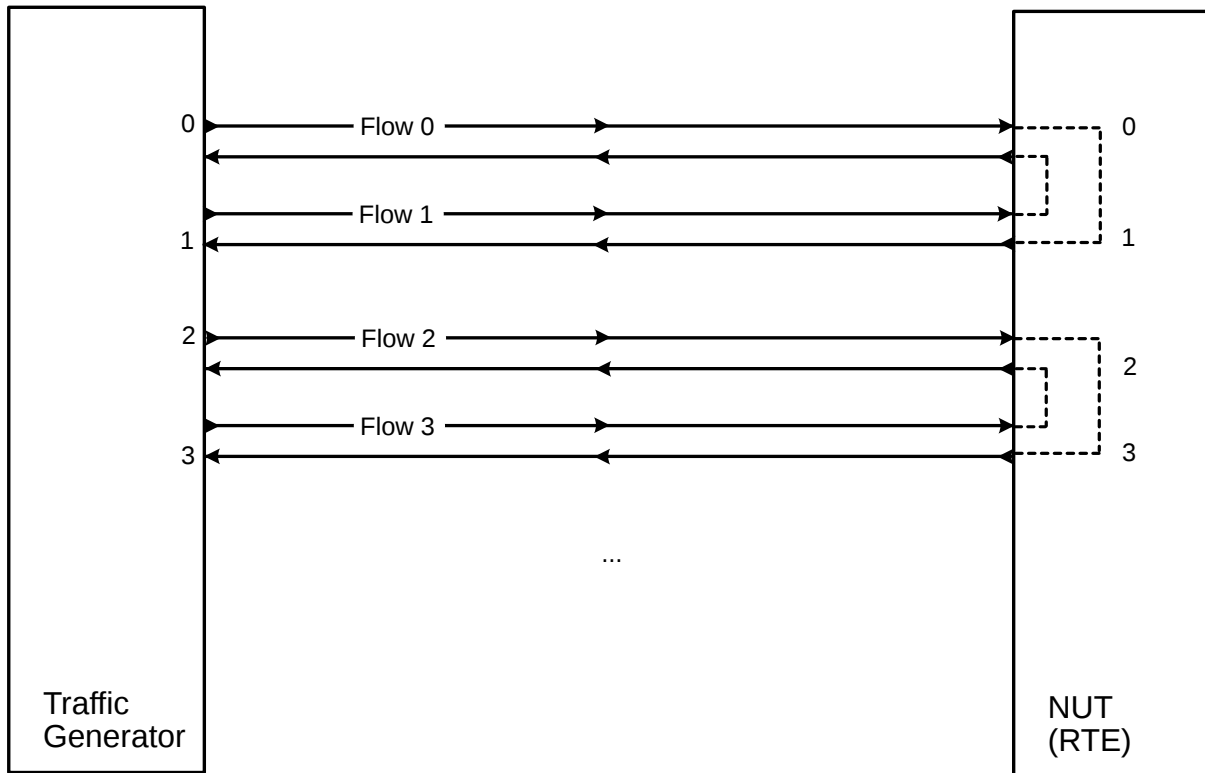

Figure 11.1: Performance Benchmark Setup (Basic Environment)

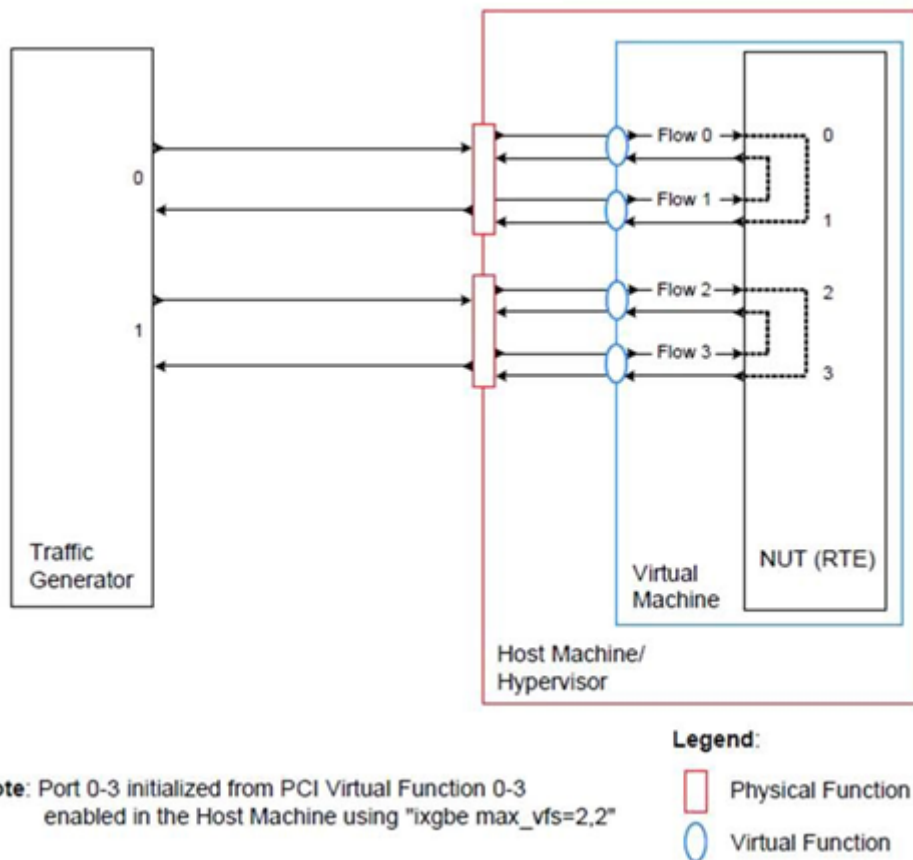

Figure 11.2: Performance Benchmark Setup (Virtualized Environment)

```
modprobe ixgbe max_vfs=2,2
```

This command enables two Virtual Functions on each of Physical Function of the NIC, with two physical ports in the PCI configuration space. It is important to note that enabled Virtual Function 0 and 2 would belong to Physical Function 0 and Virtual Function 1 and 3 would belong to Physical Function 1, in this case enabling a total of four Virtual Functions.

## 11.2 Compiling the Application

1. Go to the example directory:

```
export RTE_SDK=/path/to/rte_sdk cd ${RTE_SDK}/examples/l2fwd-jobstats
```

2. Set the target (a default target is used if not specified). For example:

```
export RTE_TARGET=x86_64-native-linuxapp-gcc
```

See the *DPDK Getting Started Guide* for possible RTE\_TARGET values.

3. Build the application:

```
make
```

## 11.3 Running the Application

The application requires a number of command line options:

```
./build/l2fwd-jobstats [EAL options] -- -p PORTMASK [-q NQ] [-l]
```

where,

- p PORTMASK: A hexadecimal bitmask of the ports to configure
- q NQ: A number of queues (=ports) per lcore (default is 1)
- l: Use locale thousands separator when formatting big numbers.

To run the application in linuxapp environment with 4 lcores, 16 ports, 8 RX queues per lcore and thousands separator printing, issue the command:

```
$ ./build/l2fwd-jobstats -c f -n 4 -- -q 8 -p ffff -l
```

Refer to the *DPDK Getting Started Guide* for general information on running applications and the Environment Abstraction Layer (EAL) options.

## 11.4 Explanation

The following sections provide some explanation of the code.

### 11.4.1 Command Line Arguments

The L2 Forwarding sample application takes specific parameters, in addition to Environment Abstraction Layer (EAL) arguments (see previous section). The preferred way to parse parameters is to use the `getopt()` function, since it is part of a well-defined and portable library.

The parsing of arguments is done in the `l2fwd_parse_args()` function. The method of argument parsing is not described here. Refer to the *glibc getopt(3)* man page for details.

EAL arguments are parsed first, then application-specific arguments. This is done at the beginning of the `main()` function:

```
/* init EAL */
ret = rte_eal_init(argc, argv);
if (ret < 0)
    rte_exit(EXIT_FAILURE, "Invalid EAL arguments\n");

argc -= ret;
argv += ret;

/* parse application arguments (after the EAL ones) */
ret = l2fwd_parse_args(argc, argv);
if (ret < 0)
    rte_exit(EXIT_FAILURE, "Invalid L2FWD arguments\n");
```

### 11.4.2 Mbuf Pool Initialization

Once the arguments are parsed, the mbuf pool is created. The mbuf pool contains a set of mbuf objects that will be used by the driver and the application to store network packet data:

```
/* create the mbuf pool */
l2fwd_pktmbuf_pool =
    rte_mempool_create("mbuf_pool", NB_MBUF,
                      MBUF_SIZE, 32,
                      sizeof(struct rte_pktmbuf_pool_private),
                      rte_pktmbuf_pool_init, NULL,
                      rte_pktmbuf_init, NULL,
                      rte_socket_id(), 0);

if (l2fwd_pktmbuf_pool == NULL)
    rte_exit(EXIT_FAILURE, "Cannot init mbuf pool\n");
```

The `rte_mempool` is a generic structure used to handle pools of objects. In this case, it is necessary to create a pool that will be used by the driver, which expects to have some reserved space in the mempool structure, `sizeof(struct rte_pktmbuf_pool_private)` bytes. The number of allocated pkt mbufs is `NB_MBUF`, with a size of `MBUF_SIZE` each. A per-lcore cache of 32 mbufs is kept. The memory is allocated in `rte_socket_id()` socket, but it is possible to extend this code to allocate one mbuf pool per socket.

Two callback pointers are also given to the `rte_mempool_create()` function:

- The first callback pointer is to `rte_pktmbuf_pool_init()` and is used to initialize the private data of the mempool, which is needed by the driver. This function is provided by the mbuf API, but can be copied and extended by the developer.

- The second callback pointer given to `rte_mempool_create()` is the mbuf initializer. The default is used, that is, `rte_pktmbuf_init()`, which is provided in the `rte_mbuf` library. If a more complex application wants to extend the `rte_pktmbuf` structure for its own needs, a new function derived from `rte_pktmbuf_init()` can be created.

### 11.4.3 Driver Initialization

The main part of the code in the `main()` function relates to the initialization of the driver. To fully understand this code, it is recommended to study the chapters that related to the Poll Mode Driver in the *DPDK Programmer's Guide* and the *DPDK API Reference*.

```

nb_ports = rte_eth_dev_count();

if (nb_ports == 0)
    rte_exit(EXIT_FAILURE, "No Ethernet ports - bye\n");

if (nb_ports > RTE_MAX_ETHPORTS)
    nb_ports = RTE_MAX_ETHPORTS;

/* reset l2fwd_dst_ports */

for (portid = 0; portid < RTE_MAX_ETHPORTS; portid++)
    l2fwd_dst_ports[portid] = 0;

last_port = 0;

/*
 * Each logical core is assigned a dedicated TX queue on each port.
 */
for (portid = 0; portid < nb_ports; portid++) {
    /* skip ports that are not enabled */
    if ((l2fwd_enabled_port_mask & (1 << portid)) == 0)
        continue;

    if (nb_ports_in_mask % 2) {
        l2fwd_dst_ports[portid] = last_port;
        l2fwd_dst_ports[last_port] = portid;
    }
    else
        last_port = portid;

    nb_ports_in_mask++;

    rte_eth_dev_info_get((uint8_t) portid, &dev_info);
}

```

The next step is to configure the RX and TX queues. For each port, there is only one RX queue (only one lcore is able to poll a given port). The number of TX queues depends on the number of available lcores. The `rte_eth_dev_configure()` function is used to configure the number of queues for a port:

```

ret = rte_eth_dev_configure((uint8_t)portid, 1, 1, &port_conf);
if (ret < 0)
    rte_exit(EXIT_FAILURE, "Cannot configure device: "
            "err=%d, port=%u\n",
            ret, portid);

```

The global configuration is stored in a static structure:



```

static const struct rte_eth_conf port_conf = {
    .rxmode = {
        .split_hdr_size = 0,
        .header_split = 0, /**< Header Split disabled */
        .hw_ip_checksum = 0, /**< IP checksum offload disabled */
        .hw_vlan_filter = 0, /**< VLAN filtering disabled */
        .jumbo_frame = 0, /**< Jumbo Frame Support disabled */
        .hw_strip_crc = 0, /**< CRC stripped by hardware */
    },

    .txmode = {
        .mq_mode = ETH_DCB_NONE
    },
};

```

#### 11.4.4 RX Queue Initialization

The application uses one lcore to poll one or several ports, depending on the -q option, which specifies the number of queues per lcore.

For example, if the user specifies -q 4, the application is able to poll four ports with one lcore. If there are 16 ports on the target (and if the portmask argument is -p ffff ), the application will need four lcores to poll all the ports.

```

ret = rte_eth_rx_queue_setup(portid, 0, nb_rxd,
    rte_eth_dev_socket_id(portid),
    NULL,
    l2fwd_pktmbuf_pool);

if (ret < 0)
    rte_exit(EXIT_FAILURE, "rte_eth_rx_queue_setup:err=%d, port=%u\n",
        ret, (unsigned) portid);

```

The list of queues that must be polled for a given lcore is stored in a private structure called struct lcore\_queue\_conf.

```

struct lcore_queue_conf {
    unsigned n_rx_port;
    unsigned rx_port_list[MAX_RX_QUEUE_PER_LCORE];
    struct mbuf_table tx_mbufs[RTE_MAX_ETHPORTS];

    struct rte_timer rx_timers[MAX_RX_QUEUE_PER_LCORE];
    struct rte_jobstats port_fwd_jobs[MAX_RX_QUEUE_PER_LCORE];

    struct rte_timer flush_timer;
    struct rte_jobstats flush_job;
    struct rte_jobstats idle_job;
    struct rte_jobstats_context jobs_context;

    rte_atomic16_t stats_read_pending;
    rte_spinlock_t lock;
} __rte_cache_aligned;

```

Values of struct lcore\_queue\_conf:

- n\_rx\_port and rx\_port\_list[] are used in the main packet processing loop (see the “Receive, Process and Transmit Packets” below).
- rx\_timers and flush\_timer are used to ensure forced TX on low packet rate.

- flush\_job, idle\_job and jobs\_context are librte\_jobstats objects used for managing l2fwd jobs.
- stats\_read\_pending and lock are used during job stats read phase.

#### 11.4.5 TX Queue Initialization

Each lcore should be able to transmit on any port. For every port, a single TX queue is initialized.

```
/* init one TX queue on each port */

fflush(stdout);
ret = rte_eth_tx_queue_setup(portid, 0, nb_txd,
    rte_eth_dev_socket_id(portid),
    NULL);
if (ret < 0)
    rte_exit(EXIT_FAILURE, "rte_eth_tx_queue_setup:err=%d, port=%u\n",
        ret, (unsigned) portid);
```

#### 11.4.6 Jobs statistics initialization

There are several statistics objects available:

- Flush job statistics

```
rte_jobstats_init(&qconf->flush_job, "flush", drain_tsc, drain_tsc,
    drain_tsc, 0);

rte_timer_init(&qconf->flush_timer);
ret = rte_timer_reset(&qconf->flush_timer, drain_tsc, PERIODICAL,
    lcore_id, &l2fwd_flush_job, NULL);

if (ret < 0) {
    rte_exit(1, "Failed to reset flush job timer for lcore %u: %s",
        lcore_id, rte_strerror(-ret));
}
```

- Statistics per RX port

```
rte_jobstats_init(job, name, 0, drain_tsc, 0, MAX_PKT_BURST);
rte_jobstats_set_update_period_function(job, l2fwd_job_update_cb);

rte_timer_init(&qconf->rx_timers[i]);
ret = rte_timer_reset(&qconf->rx_timers[i], 0, PERIODICAL, lcore_id,
    l2fwd_fwd_job, (void *) (uintptr_t) i);

if (ret < 0) {
    rte_exit(1, "Failed to reset lcore %u port %u job timer: %s",
        lcore_id, qconf->rx_port_list[i], rte_strerror(-ret));
}
```

Following parameters are passed to rte\_jobstats\_init():

- 0 as minimal poll period
- drain\_tsc as maximum poll period
- MAX\_PKT\_BURST as desired target value (RX burst size)

### 11.4.7 Main loop

The forwarding path is reworked comparing to original L2 Forwarding application. In the `l2fwd_main_loop()` function three loops are placed.

```

for (;;) {
    rte_spinlock_lock(&qconf->lock);

    do {
        rte_jobstats_context_start(&qconf->jobs_context);

        /* Do the Idle job:
         * - Read stats_read_pending flag
         * - check if some real job need to be executed
         */
        rte_jobstats_start(&qconf->jobs_context, &qconf->idle_job);

        do {
            uint8_t i;
            uint64_t now = rte_get_timer_cycles();

            need_manage = qconf->flush_timer.expire < now;
            /* Check if we was esked to give a stats. */
            stats_read_pending =
                rte_atomic16_read(&qconf->stats_read_pending);
            need_manage |= stats_read_pending;

            for (i = 0; i < qconf->n_rx_port && !need_manage; i++)
                need_manage = qconf->rx_timers[i].expire < now;

        } while (!need_manage);
        rte_jobstats_finish(&qconf->idle_job, qconf->idle_job.target);

        rte_timer_manage();
        rte_jobstats_context_finish(&qconf->jobs_context);
    } while (likely(stats_read_pending == 0));

    rte_spinlock_unlock(&qconf->lock);
    rte_pause();
}

```

First infinite for loop is to minimize impact of stats reading. Lock is only locked/unlocked when asked.

Second inner while loop do the whole jobs management. When any job is ready, the use `rte_timer_manage()` is used to call the job handler. In this place functions `l2fwd_fwd_job()` and `l2fwd_flush_job()` are called when needed. Then `rte_jobstats_context_finish()` is called to mark loop end - no other jobs are ready to execute. By this time stats are ready to be read and if `stats_read_pending` is set, loop breaks allowing stats to be read.

Third do-while loop is the idle job (idle stats counter). Its only purpose is monitoring if any job is ready or stats job read is pending for this lcore. Statistics from this part of code is considered as the headroom available for additional processing.

### 11.4.8 Receive, Process and Transmit Packets

The main task of `l2fwd_fwd_job()` function is to read ingress packets from the RX queue of particular port and forward it. This is done using the following code:

```
total_nb_rx = rte_eth_rx_burst((uint8_t) portid, 0, pkts_burst,
                               MAX_PKT_BURST);

for (j = 0; j < total_nb_rx; j++) {
    m = pkts_burst[j];
    rte_prefetch0(rte_pktmbuf_mtod(m, void *));
    l2fwd_simple_forward(m, portid);
}
```

Packets are read in a burst of size MAX\_PKT\_BURST. Then, each mbuf in the table is processed by the l2fwd\_simple\_forward() function. The processing is very simple: process the TX port from the RX port, then replace the source and destination MAC addresses.

The rte\_eth\_rx\_burst() function writes the mbuf pointers in a local table and returns the number of available mbufs in the table.

After first read second try is issued.

```
if (total_nb_rx == MAX_PKT_BURST) {
    const uint16_t nb_rx = rte_eth_rx_burst((uint8_t) portid, 0, pkts_burst,
                                             MAX_PKT_BURST);

    total_nb_rx += nb_rx;
    for (j = 0; j < nb_rx; j++) {
        m = pkts_burst[j];
        rte_prefetch0(rte_pktmbuf_mtod(m, void *));
        l2fwd_simple_forward(m, portid);
    }
}
```

This second read is important to give job stats library a feedback how many packets was processed.

```
/* Adjust period time in which we are running here. */
if (rte_jobstats_finish(job, total_nb_rx) != 0) {
    rte_timer_reset(&qconf->rx_timers[port_idx], job->period, PERIODICAL,
                   lcore_id, l2fwd_fwd_job, arg);
}
```

To maximize performance exactly MAX\_PKT\_BURST is expected (the target value) to be read for each l2fwd\_fwd\_job() call. If total\_nb\_rx is smaller than target value job->period will be increased. If it is greater the period will be decreased.

**Note:** In the following code, one line for getting the output port requires some explanation.

During the initialization process, a static array of destination ports (l2fwd\_dst\_ports[]) is filled such that for each source port, a destination port is assigned that is either the next or previous enabled port from the portmask. Naturally, the number of ports in the portmask must be even, otherwise, the application exits.

```
static void
l2fwd_simple_forward(struct rte_mbuf *m, unsigned portid)
{
    struct ether_hdr *eth;
    void *tmp;
    unsigned dst_port;

    dst_port = l2fwd_dst_ports[portid];
}
```

```

eth = rte_pktmbuf_mtod(m, struct ether_hdr *);
/* 02:00:00:00:00:xx */
tmp = &eth->d_addr.addr_bytes[0];
*((uint64_t *)tmp) = 0x00000000000002 + ((uint64_t) dst_port << 40);
/* src addr */
ether_addr_copy(&l2fwd_ports_eth_addr[dst_port], &eth->s_addr);
l2fwd_send_packet(m, (uint8_t) dst_port);
}

```

Then, the packet is sent using the `l2fwd_send_packet(m, dst_port)` function. For this test application, the processing is exactly the same for all packets arriving on the same RX port. Therefore, it would have been possible to call the `l2fwd_send_burst()` function directly from the main loop to send all the received packets on the same TX port, using the burst-oriented send function, which is more efficient.

However, in real-life applications (such as, L3 routing), packet N is not necessarily forwarded on the same port as packet N-1. The application is implemented to illustrate that, so the same approach can be reused in a more complex application.

The `l2fwd_send_packet()` function stores the packet in a per-lcore and per-txport table. If the table is full, the whole packets table is transmitted using the `l2fwd_send_burst()` function:

```

/* Send the packet on an output interface */
static int
l2fwd_send_packet(struct rte_mbuf *m, uint8_t port)
{
    unsigned lcore_id, len;
    struct lcore_queue_conf *qconf;

    lcore_id = rte_lcore_id();
    qconf = &lcore_queue_conf[lcore_id];
    len = qconf->tx_mbufs[port].len;
    qconf->tx_mbufs[port].m_table[len] = m;
    len++;

    /* enough pkts to be sent */

    if (unlikely(len == MAX_PKT_BURST)) {
        l2fwd_send_burst(qconf, MAX_PKT_BURST, port);
        len = 0;
    }

    qconf->tx_mbufs[port].len = len; return 0;
}

```

To ensure that no packets remain in the tables, the flush job exists. The `l2fwd_flush_job()` is called periodically to for each lcore draining TX queue of each port. This technique introduces some latency when there are not many packets to send, however it improves performance:

```

static void
l2fwd_flush_job(__rte_unused struct rte_timer *timer, __rte_unused void *arg)
{
    uint64_t now;
}

```

```
    unsigned lcore_id;
    struct lcore_queue_conf *qconf;
    struct mbuf_table *m_table;
    uint8_t portid;

    lcore_id = rte_lcore_id();
    qconf = &lcore_queue_conf[lcore_id];

    rte_jobstats_start(&qconf->jobs_context, &qconf->flush_job);

    now = rte_get_timer_cycles();
    lcore_id = rte_lcore_id();
    qconf = &lcore_queue_conf[lcore_id];
    for (portid = 0; portid < RTE_MAX_ETHPORTS; portid++) {
        m_table = &qconf->tx_mbufs[portid];
        if (m_table->len == 0 || m_table->next_flush_time <= now)
            continue;

        l2fwd_send_burst(qconf, portid);
    }

    /* Pass target to indicate that this job is happy of time interval
     * in which it was called. */
    rte_jobstats_finish(&qconf->flush_job, qconf->flush_job.target);
}
```

## L2 FORWARDING SAMPLE APPLICATION (IN REAL AND VIRTUALIZED ENVIRONMENTS)

The L2 Forwarding sample application is a simple example of packet processing using the Data Plane Development Kit (DPDK) which also takes advantage of Single Root I/O Virtualization (SR-IOV) features in a virtualized environment.

---

**Note:** Please note that previously a separate L2 Forwarding in Virtualized Environments sample application was used, however, in later DPDK versions these sample applications have been merged.

---

### 12.1 Overview

The L2 Forwarding sample application, which can operate in real and virtualized environments, performs L2 forwarding for each packet that is received on an RX\_PORT. The destination port is the adjacent port from the enabled portmask, that is, if the first four ports are enabled (portmask 0xf), ports 1 and 2 forward into each other, and ports 3 and 4 forward into each other. Also, the MAC addresses are affected as follows:

- The source MAC address is replaced by the TX\_PORT MAC address
- The destination MAC address is replaced by 02:00:00:00:00:TX\_PORT\_ID

This application can be used to benchmark performance using a traffic-generator, as shown in the Fig. 12.1.

The application can also be used in a virtualized environment as shown in Fig. 12.2.

The L2 Forwarding application can also be used as a starting point for developing a new application based on the DPDK.

#### 12.1.1 Virtual Function Setup Instructions

This application can use the virtual function available in the system and therefore can be used in a virtual machine without passing through the whole Network Device into a guest machine in a virtualized scenario. The virtual functions can be enabled in the host machine or the hypervisor with the respective physical function driver.

For example, in a Linux\* host machine, it is possible to enable a virtual function using the following command:

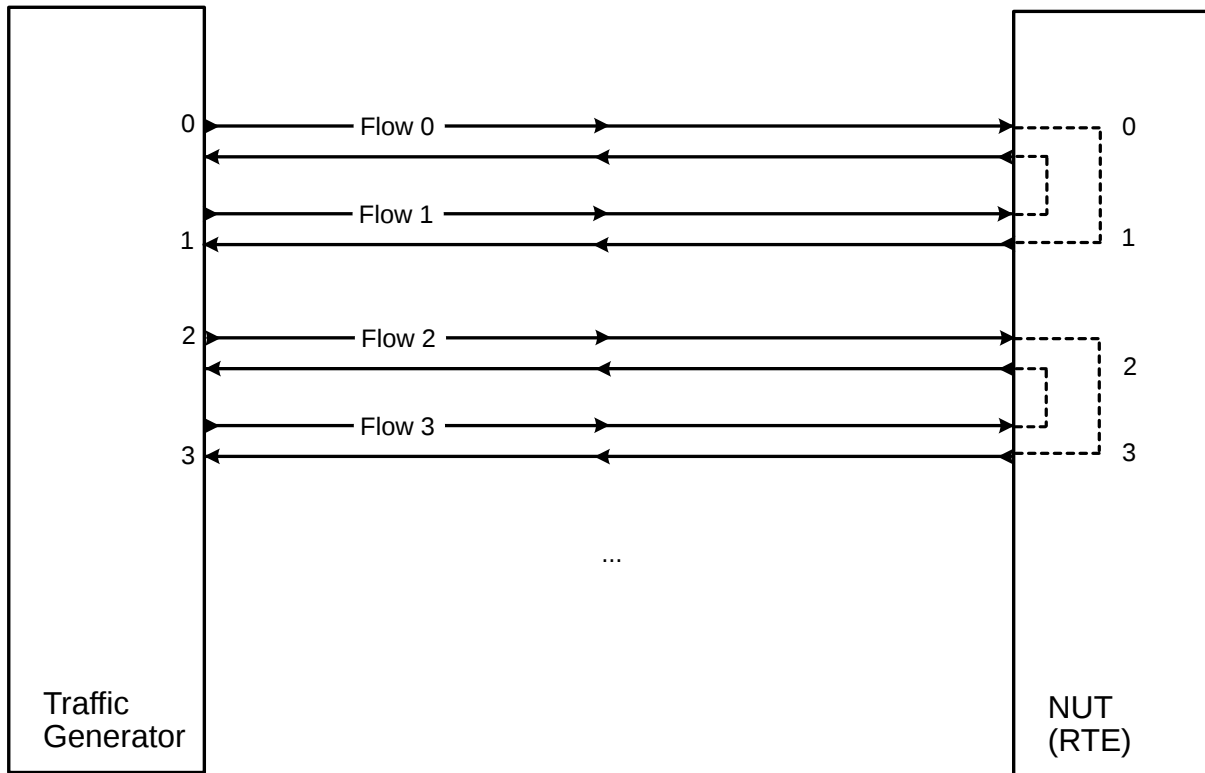

Figure 12.1: Performance Benchmark Setup (Basic Environment)

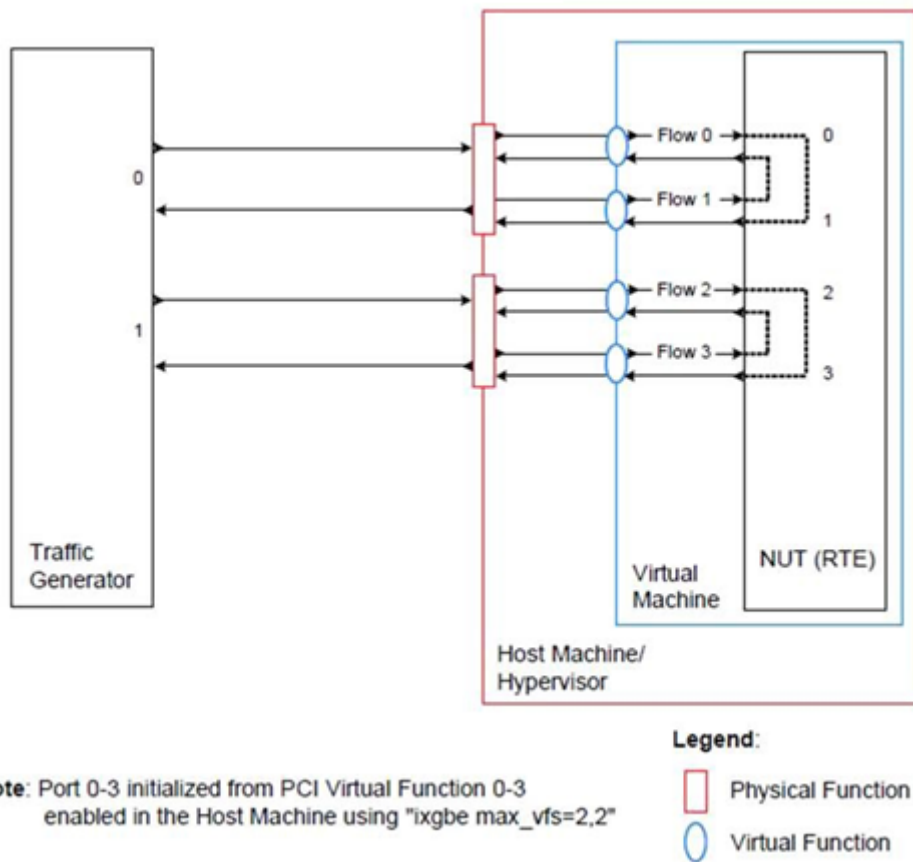

Figure 12.2: Performance Benchmark Setup (Virtualized Environment)



```
modprobe ixgbe max_vfs=2,2
```

This command enables two Virtual Functions on each of Physical Function of the NIC, with two physical ports in the PCI configuration space. It is important to note that enabled Virtual Function 0 and 2 would belong to Physical Function 0 and Virtual Function 1 and 3 would belong to Physical Function 1, in this case enabling a total of four Virtual Functions.

## 12.2 Compiling the Application

1. Go to the example directory:

```
export RTE_SDK=/path/to/rte_sdk cd ${RTE_SDK}/examples/l2fwd
```

2. Set the target (a default target is used if not specified). For example:

```
export RTE_TARGET=x86_64-native-linuxapp-gcc
```

See the *DPDK Getting Started Guide* for possible RTE\_TARGET values.

3. Build the application:

```
make
```

## 12.3 Running the Application

The application requires a number of command line options:

```
./build/l2fwd [EAL options] -- -p PORTMASK [-q NQ]
```

where,

- p PORTMASK: A hexadecimal bitmask of the ports to configure
- q NQ: A number of queues (=ports) per lcore (default is 1)

To run the application in linuxapp environment with 4 lcores, 16 ports and 8 RX queues per lcore, issue the command:

```
$ ./build/l2fwd -c f -n 4 -- -q 8 -p ffff
```

Refer to the *DPDK Getting Started Guide* for general information on running applications and the Environment Abstraction Layer (EAL) options.

## 12.4 Explanation

The following sections provide some explanation of the code.

### 12.4.1 Command Line Arguments

The L2 Forwarding sample application takes specific parameters, in addition to Environment Abstraction Layer (EAL) arguments (see above). The preferred way to parse parameters is to use the `getopt()` function, since it is part of a well-defined and portable library.

The parsing of arguments is done in the `l2fwd_parse_args()` function. The method of argument parsing is not described here. Refer to the *glibc getopt(3)* man page for details.

EAL arguments are parsed first, then application-specific arguments. This is done at the beginning of the `main()` function:

```
/* init EAL */
ret = rte_eal_init(argc, argv);
if (ret < 0)
    rte_exit(EXIT_FAILURE, "Invalid EAL arguments\n");

argc -= ret;
argv += ret;

/* parse application arguments (after the EAL ones) */
ret = l2fwd_parse_args(argc, argv);
if (ret < 0)
    rte_exit(EXIT_FAILURE, "Invalid L2FWD arguments\n");
```

### 12.4.2 Mbuf Pool Initialization

Once the arguments are parsed, the mbuf pool is created. The mbuf pool contains a set of mbuf objects that will be used by the driver and the application to store network packet data:

```
/* create the mbuf pool */

l2fwd_pktmbuf_pool = rte_mempool_create("mbuf_pool", NB_MBUF, MBUF_SIZE, 32, sizeof(struct rte_mbuf),
    rte_pktmbuf_pool_init, NULL, rte_pktmbuf_init, NULL, SOCKET0, 0);

if (l2fwd_pktmbuf_pool == NULL)
    rte_panic("Cannot init mbuf pool\n");
```

The `rte_mempool` is a generic structure used to handle pools of objects. In this case, it is necessary to create a pool that will be used by the driver, which expects to have some reserved space in the mempool structure, `sizeof(struct rte_pktmbuf_pool_private)` bytes. The number of allocated pkt mbufs is `NB_MBUF`, with a size of `MBUF_SIZE` each. A per-lcore cache of 32 mbufs is kept. The memory is allocated in NUMA socket 0, but it is possible to extend this code to allocate one mbuf pool per socket.

Two callback pointers are also given to the `rte_mempool_create()` function:

- The first callback pointer is to `rte_pktmbuf_pool_init()` and is used to initialize the private data of the mempool, which is needed by the driver. This function is provided by the mbuf API, but can be copied and extended by the developer.
- The second callback pointer given to `rte_mempool_create()` is the mbuf initializer. The default is used, that is, `rte_pktmbuf_init()`, which is provided in the `rte_mbuf` library. If a more complex application wants to extend the `rte_pktmbuf` structure for its own needs, a new function derived from `rte_pktmbuf_init()` can be created.

### 12.4.3 Driver Initialization

The main part of the code in the `main()` function relates to the initialization of the driver. To fully understand this code, it is recommended to study the chapters that related to the Poll Mode Driver in the *DPDK Programmer's Guide - Rel 1.4 EAR* and the *DPDK API Reference*.

```

if (rte_eal_pci_probe() < 0)
    rte_exit(EXIT_FAILURE, "Cannot probe PCI\n");

nb_ports = rte_eth_dev_count();

if (nb_ports == 0)
    rte_exit(EXIT_FAILURE, "No Ethernet ports - bye\n");

if (nb_ports > RTE_MAX_ETHPORTS)
    nb_ports = RTE_MAX_ETHPORTS;

/* reset l2fwd_dst_ports */

for (portid = 0; portid < RTE_MAX_ETHPORTS; portid++)
    l2fwd_dst_ports[portid] = 0;

last_port = 0;

/*
 * Each logical core is assigned a dedicated TX queue on each port.
 */

for (portid = 0; portid < nb_ports; portid++) {
    /* skip ports that are not enabled */

    if ((l2fwd_enabled_port_mask & (1 << portid)) == 0)
        continue;

    if (nb_ports_in_mask % 2) {
        l2fwd_dst_ports[portid] = last_port;
        l2fwd_dst_ports[last_port] = portid;
    }
    else
        last_port = portid;

    nb_ports_in_mask++;

    rte_eth_dev_info_get((uint8_t) portid, &dev_info);
}

```

Observe that:

- `rte_igb_pmd_init_all()` simultaneously registers the driver as a PCI driver and as an Ethernet\* Poll Mode Driver.
- `rte_eal_pci_probe()` parses the devices on the PCI bus and initializes recognized devices.

The next step is to configure the RX and TX queues. For each port, there is only one RX queue (only one lcore is able to poll a given port). The number of TX queues depends on the number of available lcores. The `rte_eth_dev_configure()` function is used to configure the number of queues for a port:

```

ret = rte_eth_dev_configure((uint8_t)portid, 1, 1, &port_conf);
if (ret < 0)
    rte_exit(EXIT_FAILURE, "Cannot configure device: "

```

```
"err=%d, port=%u\n",
ret, portid);
```

The global configuration is stored in a static structure:

```
static const struct rte_eth_conf port_conf = {
    .rxmode = {
        .split_hdr_size = 0,
        .header_split = 0, /**< Header Split disabled */
        .hw_ip_checksum = 0, /**< IP checksum offload disabled */
        .hw_vlan_filter = 0, /**< VLAN filtering disabled */
        .jumbo_frame = 0, /**< Jumbo Frame Support disabled */
        .hw_strip_crc = 0, /**< CRC stripped by hardware */
    },
    .txmode = {
        .mq_mode = ETH_DCB_NONE
    },
};
```

#### 12.4.4 RX Queue Initialization

The application uses one lcore to poll one or several ports, depending on the -q option, which specifies the number of queues per lcore.

For example, if the user specifies -q 4, the application is able to poll four ports with one lcore. If there are 16 ports on the target (and if the portmask argument is -p ffff), the application will need four lcores to poll all the ports.

```
ret = rte_eth_rx_queue_setup((uint8_t) portid, 0, nb_rxd, SOCKET0, &rx_conf, l2fwd_pktmbuf_pool);
if (ret < 0)

    rte_exit(EXIT_FAILURE, "rte_eth_rx_queue_setup: "
        "err=%d, port=%u\n",
        ret, portid);
```

The list of queues that must be polled for a given lcore is stored in a private structure called struct lcore\_queue\_conf.

```
struct lcore_queue_conf {
    unsigned n_rx_port;
    unsigned rx_port_list[MAX_RX_QUEUE_PER_LCORE];
    struct mbuf_table tx_mbufs[L2FWD_MAX_PORTS];
} rte_cache_aligned;

struct lcore_queue_conf lcore_queue_conf[RTE_MAX_LCORE];
```

The values n\_rx\_port and rx\_port\_list[] are used in the main packet processing loop (see the “Receive, Process and Transmit Packets” section below).

The global configuration for the RX queues is stored in a static structure:

```
static const struct rte_eth_rxconf rx_conf = {
    .rx_thresh = {
        .pthresh = RX_PTHRESH,
        .hthresh = RX_HTHRESH,
        .wthresh = RX_WTHRESH,
    },
};
```

### 12.4.5 TX Queue Initialization

Each lcore should be able to transmit on any port. For every port, a single TX queue is initialized.

```
/* init one TX queue on each port */

fflush(stdout);

ret = rte_eth_tx_queue_setup((uint8_t) portid, 0, nb_txd, rte_eth_dev_socket_id(portid), &tx_c
if (ret < 0)
    rte_exit(EXIT_FAILURE, "rte_eth_tx_queue_setup:err=%d, port=%u\n", ret, (unsigned) portid)
```

The global configuration for TX queues is stored in a static structure:

```
static const struct rte_eth_txconf tx_conf = {
    .tx_thresh = {
        .pthresh = TX_PTHRESH,
        .hthresh = TX_HTHRESH,
        .wthresh = TX_WTHRESH,
    },
    .tx_free_thresh = RTE_TEST_TX_DESC_DEFAULT + 1, /* disable feature */
};
```

### 12.4.6 Receive, Process and Transmit Packets

In the `l2fwd_main_loop()` function, the main task is to read ingress packets from the RX queues. This is done using the following code:

```
/*
 * Read packet from RX queues
 */

for (i = 0; i < qconf->n_rx_port; i++) {
    portid = qconf->rx_port_list[i];
    nb_rx = rte_eth_rx_burst((uint8_t) portid, 0, pkts_burst, MAX_PKT_BURST);

    for (j = 0; j < nb_rx; j++) {
        m = pkts_burst[j];
        rte_prefetch0[rte_pktmbuf_mtod(m, void *)]; l2fwd_simple_forward(m, portid);
    }
}
```

Packets are read in a burst of size `MAX_PKT_BURST`. The `rte_eth_rx_burst()` function writes the mbuf pointers in a local table and returns the number of available mbufs in the table.

Then, each mbuf in the table is processed by the `l2fwd_simple_forward()` function. The processing is very simple: process the TX port from the RX port, then replace the source and destination MAC addresses.

---

**Note:** In the following code, one line for getting the output port requires some explanation.

---

During the initialization process, a static array of destination ports (`l2fwd_dst_ports[]`) is filled such that for each source port, a destination port is assigned that is either the next or previous enabled port from the portmask. Naturally, the number of ports in the portmask must be even, otherwise, the application exits.

```

static void
l2fwd_simple_forward(struct rte_mbuf *m, unsigned portid)
{
    struct ether_hdr *eth;
    void *tmp;
    unsigned dst_port;

    dst_port = l2fwd_dst_ports[portid];

    eth = rte_pktmbuf_mtod(m, struct ether_hdr *);

    /* 02:00:00:00:00:xx */
    tmp = &eth->d_addr.addr_bytes[0];

    *((uint64_t *)tmp) = 0x000000000002 + ((uint64_t) dst_port << 40);

    /* src addr */
    ether_addr_copy(&l2fwd_ports_eth_addr[dst_port], &eth->s_addr);

    l2fwd_send_packet(m, (uint8_t) dst_port);
}

```

Then, the packet is sent using the `l2fwd_send_packet(m, dst_port)` function. For this test application, the processing is exactly the same for all packets arriving on the same RX port. Therefore, it would have been possible to call the `l2fwd_send_burst()` function directly from the main loop to send all the received packets on the same TX port, using the burst-oriented send function, which is more efficient.

However, in real-life applications (such as, L3 routing), packet N is not necessarily forwarded on the same port as packet N-1. The application is implemented to illustrate that, so the same approach can be reused in a more complex application.

The `l2fwd_send_packet()` function stores the packet in a per-lcore and per-txport table. If the table is full, the whole packets table is transmitted using the `l2fwd_send_burst()` function:

```

/* Send the packet on an output interface */

static int
l2fwd_send_packet(struct rte_mbuf *m, uint8_t port)
{
    unsigned lcore_id, len;
    struct lcore_queue_conf *qconf;

    lcore_id = rte_lcore_id();
    qconf = &lcore_queue_conf[lcore_id];
    len = qconf->tx_mbufs[port].len;
    qconf->tx_mbufs[port].m_table[len] = m;
    len++;

    /* enough pkts to be sent */

    if (unlikely(len == MAX_PKT_BURST)) {
        l2fwd_send_burst(qconf, MAX_PKT_BURST, port);
        len = 0;
    }

    qconf->tx_mbufs[port].len = len; return 0;
}

```

To ensure that no packets remain in the tables, each lcore does a draining of TX queue in its main loop. This technique introduces some latency when there are not many packets to send, however it improves performance:

```

cur_tsc = rte_rdtsc();

/*
 * TX burst queue drain
 */

diff_tsc = cur_tsc - prev_tsc;

if (unlikely(diff_tsc > drain_tsc)) {
    for (portid = 0; portid < RTE_MAX_ETHPORTS; portid++) {
        if (qconf->tx_mbufs[portid].len == 0)
            continue;

        l2fwd_send_burst(&lcore_queue_conf[lcore_id], qconf->tx_mbufs[portid].len, (uint8_t) p

        qconf->tx_mbufs[portid].len = 0;
    }

    /* if timer is enabled */

    if (timer_period > 0) {
        /* advance the timer */

        timer_tsc += diff_tsc;

        /* if timer has reached its timeout */

        if (unlikely(timer_tsc >= (uint64_t) timer_period)) {
            /* do this only on master core */

            if (lcore_id == rte_get_master_lcore()) {
                print_stats();

                /* reset the timer */
                timer_tsc = 0;
            }
        }
    }

    prev_tsc = cur_tsc;
}

```

## **L3 FORWARDING SAMPLE APPLICATION**

The L3 Forwarding application is a simple example of packet processing using the DPDK. The application performs L3 forwarding.

### **13.1 Overview**

The application demonstrates the use of the hash and LPM libraries in the DPDK to implement packet forwarding. The initialization and run-time paths are very similar to those of the L2 forwarding application (see Chapter 9 “L2 Forwarding Sample Application (in Real and Virtualized Environments)” for more information). The main difference from the L2 Forwarding sample application is that the forwarding decision is made based on information read from the input packet.

The lookup method is either hash-based or LPM-based and is selected at compile time. When the selected lookup method is hash-based, a hash object is used to emulate the flow classification stage. The hash object is used in correlation with a flow table to map each input packet to its flow at runtime.

The hash lookup key is represented by a DiffServ 5-tuple composed of the following fields read from the input packet: Source IP Address, Destination IP Address, Protocol, Source Port and Destination Port. The ID of the output interface for the input packet is read from the identified flow table entry. The set of flows used by the application is statically configured and loaded into the hash at initialization time. When the selected lookup method is LPM based, an LPM object is used to emulate the forwarding stage for IPv4 packets. The LPM object is used as the routing table to identify the next hop for each input packet at runtime.

The LPM lookup key is represented by the Destination IP Address field read from the input packet. The ID of the output interface for the input packet is the next hop returned by the LPM lookup. The set of LPM rules used by the application is statically configured and loaded into the LPM object at initialization time.

In the sample application, hash-based forwarding supports IPv4 and IPv6. LPM-based forwarding supports IPv4 only.

### **13.2 Compiling the Application**

To compile the application:

1. Go to the sample application directory:



```
export RTE_SDK=/path/to/rte_sdk cd ${RTE_SDK}/examples/l3fwd
```

2. Set the target (a default target is used if not specified). For example:

```
export RTE_TARGET=x86_64-native-linuxapp-gcc
```

See the *DPDK Getting Started Guide* for possible RTE\_TARGET values.

3. Build the application:

```
make
```

## 13.3 Running the Application

The application has a number of command line options:

```
./build/l3fwd [EAL options] -- -p PORTMASK [-P] --config(port,queue,lcore)[,(port,queue,lcore)
```

where,

- -p PORTMASK: Hexadecimal bitmask of ports to configure
- -P: optional, sets all ports to promiscuous mode so that packets are accepted regardless of the packet's Ethernet MAC destination address. Without this option, only packets with the Ethernet MAC destination address set to the Ethernet address of the port are accepted.
- --config (port,queue,lcore)[,(port,queue,lcore)]: determines which queues from which ports are mapped to which cores
- --enable-jumbo: optional, enables jumbo frames
- --max-pkt-len: optional, maximum packet length in decimal (64-9600)
- --no-numa: optional, disables numa awareness
- --hash-entry-num: optional, specifies the hash entry number in hexadecimal to be setup
- --ipv6: optional, set it if running ipv6 packets

For example, consider a dual processor socket platform where cores 0-7 and 16-23 appear on socket 0, while cores 8-15 and 24-31 appear on socket 1. Let's say that the programmer wants to use memory from both NUMA nodes, the platform has only two ports, one connected to each NUMA node, and the programmer wants to use two cores from each processor socket to do the packet processing.

To enable L3 forwarding between two ports, using two cores, cores 1 and 2, from each processor, while also taking advantage of local memory access by optimizing around NUMA, the programmer must enable two queues from each port, pin to the appropriate cores and allocate memory from the appropriate NUMA node. This is achieved using the following command:

```
./build/l3fwd -c 606 -n 4 -- -p 0x3 --config="(0,0,1),(0,1,2),(1,0,9),(1,1,10)"
```

In this command:

- The -c option enables cores 0, 1, 2, 3

- The `-p` option enables ports 0 and 1
- The `--config` option enables two queues on each port and maps each (port,queue) pair to a specific core. Logic to enable multiple RX queues using RSS and to allocate memory from the correct NUMA nodes is included in the application and is done transparently. The following table shows the mapping in this example:

Port	Queue	lcore	Description
0	0	0	Map queue 0 from port 0 to lcore 0.
0	1	2	Map queue 1 from port 0 to lcore 2.
1	0	1	Map queue 0 from port 1 to lcore 1.
1	1	3	Map queue 1 from port 1 to lcore 3.

Refer to the *DPDK Getting Started Guide* for general information on running applications and the Environment Abstraction Layer (EAL) options.

## 13.4 Explanation

The following sections provide some explanation of the sample application code. As mentioned in the overview section, the initialization and run-time paths are very similar to those of the L2 forwarding application (see Chapter 9 “L2 Forwarding Sample Application (in Real and Virtualized Environments)” for more information). The following sections describe aspects that are specific to the L3 Forwarding sample application.

### 13.4.1 Hash Initialization

The hash object is created and loaded with the pre-configured entries read from a global array, and then generate the expected 5-tuple as key to keep consistence with those of real flow for the convenience to execute hash performance test on 4M/8M/16M flows.

**Note:** The Hash initialization will setup both ipv4 and ipv6 hash table, and populate the either table depending on the value of variable `ipv6`. To support the hash performance test with up to 8M single direction flows/16M bi-direction flows, `populate_ipv4_many_flow_into_table()` function will populate the hash table with specified hash table entry number(default 4M).

**Note:** Value of global variable `ipv6` can be specified with `-ipv6` in the command line. Value of global variable `hash_entry_number`, which is used to specify the total hash entry number for all used ports in hash performance test, can be specified with `--hash-entry-num VALUE` in command line, being its default value 4.

```
#if (APP_LOOKUP_METHOD == APP_LOOKUP_EXACT_MATCH)

static void
setup_hash(int socketid)
{
    // ...

    if (hash_entry_number != HASH_ENTRY_NUMBER_DEFAULT) {
        if (ipv6 == 0) {
            /* populate the ipv4 hash */
            populate_ipv4_many_flow_into_table(ipv4_l3fwd_lookup_struct[socketid], hash_en
        } else {
```

```

        /* populate the ipv6 hash */
        populate_ipv6_many_flow_into_table( ipv6_l3fwd_lookup_struct[socketid], hash_e
    }
} else
    if (ipv6 == 0) {
        /* populate the ipv4 hash */
        populate_ipv4_few_flow_into_table(ipv4_l3fwd_lookup_struct[socketid]);
    } else {
        /* populate the ipv6 hash */
        populate_ipv6_few_flow_into_table(ipv6_l3fwd_lookup_struct[socketid]);
    }
}
}
#endif

```

### 13.4.2 LPM Initialization

The LPM object is created and loaded with the pre-configured entries read from a global array.

```

#if (APP_LOOKUP_METHOD == APP_LOOKUP_LPM)

static void
setup_lpm(int socketid)
{
    unsigned i;
    int ret;
    char s[64];

    /* create the LPM table */

    rte_sprintf(s, sizeof(s), "IPV4_L3FWD_LPM_%d", socketid);

    ipv4_l3fwd_lookup_struct[socketid] = rte_lpm_create(s, socketid, IPV4_L3FWD_LPM_MAX_RULES,

    if (ipv4_l3fwd_lookup_struct[socketid] == NULL)
        rte_exit(EXIT_FAILURE, "Unable to create the l3fwd LPM table"
            " on socket %d\n", socketid);

    /* populate the LPM table */

    for (i = 0; i < IPV4_L3FWD_NUM_ROUTES; i++) {
        /* skip unused ports */

        if ((1 << ipv4_l3fwd_route_array[i].if_out & enabled_port_mask) == 0)
            continue;

        ret = rte_lpm_add(ipv4_l3fwd_lookup_struct[socketid], ipv4_l3fwd_route_array[i].ip,
            ipv4_l3fwd_route_array[i].depth, ipv4_l3fwd_route_array[i].if

        if (ret < 0) {
            rte_exit(EXIT_FAILURE, "Unable to add entry %u to the "
                "l3fwd LPM table on socket %d\n", i, socketid);
        }

        printf("LPM: Adding route 0x%08x / %d (%d)\n",
            (unsigned)ipv4_l3fwd_route_array[i].ip, ipv4_l3fwd_route_array[i].depth, ipv4_l3fwd

    }
}
#endif

```

### 13.4.3 Packet Forwarding for Hash-based Lookups

For each input packet, the packet forwarding operation is done by the `l3fwd_simple_forward()` or `simple_ipv4_fwd_4pkts()` function for IPv4 packets or the `simple_ipv6_fwd_4pkts()` function for IPv6 packets. The `l3fwd_simple_forward()` function provides the basic functionality for both IPv4 and IPv6 packet forwarding for any number of burst packets received, and the packet forwarding decision (that is, the identification of the output interface for the packet) for hash-based lookups is done by the `get_ipv4_dst_port()` or `get_ipv6_dst_port()` function. The `get_ipv4_dst_port()` function is shown below:

```
static inline uint8_t
get_ipv4_dst_port(void *ipv4_hdr, uint8_t portid, lookup_struct_t *ipv4_l3fwd_lookup_struct)
{
    int ret = 0;
    union ipv4_5tuple_host key;

    ipv4_hdr = (uint8_t *)ipv4_hdr + offsetof(struct ipv4_hdr, time_to_live);

    m128i data = _mm_loadu_si128(( m128i*)(ipv4_hdr));

    /* Get 5 tuple: dst port, src port, dst IP address, src IP address and protocol */
    key.xmm = _mm_and_si128(data, mask0);

    /* Find destination port */

    ret = rte_hash_lookup(ipv4_l3fwd_lookup_struct, (const void *)&key);

    return (uint8_t)((ret < 0)? portid : ipv4_l3fwd_out_if[ret]);
}
```

The `get_ipv6_dst_port()` function is similar to the `get_ipv4_dst_port()` function.

The `simple_ipv4_fwd_4pkts()` and `simple_ipv6_fwd_4pkts()` function are optimized for continuous 4 valid ipv4 and ipv6 packets, they leverage the multiple buffer optimization to boost the performance of forwarding packets with the exact match on hash table. The key code snippet of `simple_ipv4_fwd_4pkts()` is shown below:

```
static inline void
simple_ipv4_fwd_4pkts(struct rte_mbuf* m[4], uint8_t portid, struct lcore_conf *qconf)
{
    // ...

    data[0] = _mm_loadu_si128(( m128i*)(rte_pktmbuf_mtod(m[0], unsigned char *) + sizeof(struct rte_mbuf)));
    data[1] = _mm_loadu_si128(( m128i*)(rte_pktmbuf_mtod(m[1], unsigned char *) + sizeof(struct rte_mbuf)));
    data[2] = _mm_loadu_si128(( m128i*)(rte_pktmbuf_mtod(m[2], unsigned char *) + sizeof(struct rte_mbuf)));
    data[3] = _mm_loadu_si128(( m128i*)(rte_pktmbuf_mtod(m[3], unsigned char *) + sizeof(struct rte_mbuf)));

    key[0].xmm = _mm_and_si128(data[0], mask0);
    key[1].xmm = _mm_and_si128(data[1], mask0);
    key[2].xmm = _mm_and_si128(data[2], mask0);
    key[3].xmm = _mm_and_si128(data[3], mask0);

    const void *key_array[4] = {&key[0], &key[1], &key[2], &key[3]};

    rte_hash_lookup_multi(qconf->ipv4_lookup_struct, &key_array[0], 4, ret);

    dst_port[0] = (ret[0] < 0)? portid:ipv4_l3fwd_out_if[ret[0]];
    dst_port[1] = (ret[1] < 0)? portid:ipv4_l3fwd_out_if[ret[1]];
    dst_port[2] = (ret[2] < 0)? portid:ipv4_l3fwd_out_if[ret[2]];
    dst_port[3] = (ret[3] < 0)? portid:ipv4_l3fwd_out_if[ret[3]];
}
```

```
} // ...
```

The `simple_ipv6_fwd_4pkts()` function is similar to the `simple_ipv4_fwd_4pkts()` function.

#### 13.4.4 Packet Forwarding for LPM-based Lookups

For each input packet, the packet forwarding operation is done by the `l3fwd_simple_forward()` function, but the packet forwarding decision (that is, the identification of the output interface for the packet) for LPM-based lookups is done by the `get_ipv4_dst_port()` function below:

```
static inline uint8_t
get_ipv4_dst_port(struct ipv4_hdr *ipv4_hdr, uint8_t portid, lookup_struct_t *ipv4_l3fwd_lookup_struct)
{
    uint8_t next_hop;

    return (uint8_t) ((rte_lpm_lookup(ipv4_l3fwd_lookup_struct, rte_be_to_cpu_32(ipv4_hdr->dst_ip),
    portid) > 0 ? next_hop : 0));
}
```

## L3 FORWARDING WITH POWER MANAGEMENT SAMPLE APPLICATION

### 14.1 Introduction

The L3 Forwarding with Power Management application is an example of power-aware packet processing using the DPDK. The application is based on existing L3 Forwarding sample application, with the power management algorithms to control the P-states and C-states of the Intel processor via a power management library.

### 14.2 Overview

The application demonstrates the use of the Power libraries in the DPDK to implement packet forwarding. The initialization and run-time paths are very similar to those of the L3 forwarding sample application (see Chapter 10 “L3 Forwarding Sample Application” for more information). The main difference from the L3 Forwarding sample application is that this application introduces power-aware optimization algorithms by leveraging the Power library to control P-state and C-state of processor based on packet load.

The DPDK includes poll-mode drivers to configure Intel NIC devices and their receive (Rx) and transmit (Tx) queues. The design principle of this PMD is to access the Rx and Tx descriptors directly without any interrupts to quickly receive, process and deliver packets in the user space.

In general, the DPDK executes an endless packet processing loop on dedicated IA cores that include the following steps:

- Retrieve input packets through the PMD to poll Rx queue
- Process each received packet or provide received packets to other processing cores through software queues
- Send pending output packets to Tx queue through the PMD

In this way, the PMD achieves better performance than a traditional interrupt-mode driver, at the cost of keeping cores active and running at the highest frequency, hence consuming the maximum power all the time. However, during the period of processing light network traffic, which happens regularly in communication infrastructure systems due to well-known “tidal effect”, the PMD is still busy waiting for network packets, which wastes a lot of power.

Processor performance states (P-states) are the capability of an Intel processor to switch between different supported operating frequencies and voltages. If configured correctly, according to system workload, this feature provides power savings. CPUFreq is the infrastructure provided by the Linux\* kernel to control the processor performance state capability. CPUFreq

supports a user space governor that enables setting frequency via manipulating the virtual file device from a user space application. The Power library in the DPDK provides a set of APIs for manipulating a virtual file device to allow user space application to set the CPUFreq governor and set the frequency of specific cores.

This application includes a P-state power management algorithm to generate a frequency hint to be sent to CPUFreq. The algorithm uses the number of received and available Rx packets on recent polls to make a heuristic decision to scale frequency up/down. Specifically, some thresholds are checked to see whether a specific core running an DPDK polling thread needs to increase frequency a step up based on the near to full trend of polled Rx queues. Also, it decreases frequency a step if packet processed per loop is far less than the expected threshold or the thread's sleeping time exceeds a threshold.

C-States are also known as sleep states. They allow software to put an Intel core into a low power idle state from which it is possible to exit via an event, such as an interrupt. However, there is a tradeoff between the power consumed in the idle state and the time required to wake up from the idle state (exit latency). Therefore, as you go into deeper C-states, the power consumed is lower but the exit latency is increased. Each C-state has a target residency. It is essential that when entering into a C-state, the core remains in this C-state for at least as long as the target residency in order to fully realize the benefits of entering the C-state. CPUIdle is the infrastructure provide by the Linux kernel to control the processor C-state capability. Unlike CPUFreq, CPUIdle does not provide a mechanism that allows the application to change C-state. It actually has its own heuristic algorithms in kernel space to select target C-state to enter by executing privileged instructions like HLT and MWAIT, based on the speculative sleep duration of the core. In this application, we introduce a heuristic algorithm that allows packet processing cores to sleep for a short period if there is no Rx packet received on recent polls. In this way, CPUIdle automatically forces the corresponding cores to enter deeper C-states instead of always running to the C0 state waiting for packets.

---

**Note:** To fully demonstrate the power saving capability of using C-states, it is recommended to enable deeper C3 and C6 states in the BIOS during system boot up.

---

## 14.3 Compiling the Application

To compile the application:

1. Go to the sample application directory:

```
export RTE_SDK=/path/to/rte_sdk cd ${RTE_SDK}/examples/l3fwd-power
```

2. Set the target (a default target is used if not specified). For example:

```
export RTE_TARGET=x86_64-native-linuxapp-gcc
```

See the *DPDK Getting Started Guide* for possible RTE\_TARGET values.

3. Build the application:

```
make
```

## 14.4 Running the Application

The application has a number of command line options:

```
./build/l3fwd_power [EAL options] -- -p PORTMASK [-P] --config(port,queue,lcore) [(port,queue,lcore)]
```

where,

- -p PORTMASK: Hexadecimal bitmask of ports to configure
- -P: Sets all ports to promiscuous mode so that packets are accepted regardless of the packet's Ethernet MAC destination address. Without this option, only packets with the Ethernet MAC destination address set to the Ethernet address of the port are accepted.
- --config (port,queue,lcore)[,(port,queue,lcore)]: determines which queues from which ports are mapped to which cores.
- --enable-jumbo: optional, enables jumbo frames
- --max-pkt-len: optional, maximum packet length in decimal (64-9600)
- --no-numa: optional, disables numa awareness

See Chapter 10 “L3 Forwarding Sample Application” for details. The L3fwd-power example reuses the L3fwd command line options.

## 14.5 Explanation

The following sections provide some explanation of the sample application code. As mentioned in the overview section, the initialization and run-time paths are identical to those of the L3 forwarding application. The following sections describe aspects that are specific to the L3 Forwarding with Power Management sample application.

### 14.5.1 Power Library Initialization

The Power library is initialized in the main routine. It changes the P-state governor to userspace for specific cores that are under control. The Timer library is also initialized and several timers are created later on, responsible for checking if it needs to scale down frequency at run time by checking CPU utilization statistics.

**Note:** Only the power management related initialization is shown.

```
int main(int argc, char **argv)
{
    struct lcore_conf *qconf;
    int ret;
    unsigned nb_ports;
    uint16_t queueid;
    unsigned lcore_id;
    uint64_t hz;
    uint32_t n_tx_queue, nb_lcores;
    uint8_t portid, nb_rx_queue, queue, socketid;

    // ...
}
```



```

/* init RTE timer library to be used to initialize per-core timers */
rte_timer_subsystem_init();

// ...

/* per-core initialization */
for (lcore_id = 0; lcore_id < RTE_MAX_LCORE; lcore_id++) {
    if (rte_lcore_is_enabled(lcore_id) == 0)
        continue;

    /* init power management library for a specified core */

    ret = rte_power_init(lcore_id);
    if (ret)
        rte_exit(EXIT_FAILURE, "Power management library "
                "initialization failed on core%d\n", lcore_id);

    /* init timer structures for each enabled lcore */

    rte_timer_init(&power_timers[lcore_id]);

    hz = rte_get_hpet_hz();

    rte_timer_reset(&power_timers[lcore_id], hz/TIMER_NUMBER_PER_SECOND, SINGLE, lcore_id,

    // ...
}

// ...
}

```

### 14.5.2 Monitoring Loads of Rx Queues

In general, the polling nature of the DPDK prevents the OS power management subsystem from knowing if the network load is actually heavy or light. In this sample, sampling network load work is done by monitoring received and available descriptors on NIC Rx queues in recent polls. Based on the number of returned and available Rx descriptors, this example implements algorithms to generate frequency scaling hints and speculative sleep duration, and use them to control P-state and C-state of processors via the power management library. Frequency (P-state) control and sleep state (C-state) control work individually for each logical core, and the combination of them contributes to a power efficient packet processing solution when serving light network loads.

The `rte_eth_rx_burst()` function and the newly-added `rte_eth_rx_queue_count()` function are used in the endless packet processing loop to return the number of received and available Rx descriptors. And those numbers of specific queue are passed to P-state and C-state heuristic algorithms to generate hints based on recent network load trends.

**Note:** Only power control related code is shown.

```

static
attribute ((noreturn)) int main_loop( attribute ((unused)) void *dummy)
{
    // ...
}

```

```

while (1) {
// ...

/**
 * Read packet from RX queues
 */

lcore_scaleup_hint = FREQ_CURRENT;
lcore_rx_idle_count = 0;

for (i = 0; i < qconf->n_rx_queue; ++i)
{
    rx_queue = &(qconf->rx_queue_list[i]);
    rx_queue->idle_hint = 0;
    portid = rx_queue->port_id;
    queueid = rx_queue->queue_id;

    nb_rx = rte_eth_rx_burst(portid, queueid, pkts_burst, MAX_PKT_BURST);
    stats[lcore_id].nb_rx_processed += nb_rx;

    if (unlikely(nb_rx == 0)) {
        /**
         * no packet received from rx queue, try to
         * sleep for a while forcing CPU enter deeper
         * C states.
         */

        rx_queue->zero_rx_packet_count++;

        if (rx_queue->zero_rx_packet_count <= MIN_ZERO_POLL_COUNT)
            continue;

        rx_queue->idle_hint = power_idle_heuristic(rx_queue->zero_rx_packet_count);
        lcore_rx_idle_count++;
    } else {
        rx_ring_length = rte_eth_rx_queue_count(portid, queueid);

        rx_queue->zero_rx_packet_count = 0;

        /**
         * do not scale up frequency immediately as
         * user to kernel space communication is costly
         * which might impact packet I/O for received
         * packets.
         */

        rx_queue->freq_up_hint = power_freq_scaleup_heuristic(lcore_id, rx_ring_length);
    }

    /* Prefetch and forward packets */

    // ...
}

if (likely(lcore_rx_idle_count != qconf->n_rx_queue)) {
    for (i = 1, lcore_scaleup_hint = qconf->rx_queue_list[0].freq_up_hint; i < qconf->n_rx
        x_queue = &(qconf->rx_queue_list[i]);

        if (rx_queue->freq_up_hint > lcore_scaleup_hint)

            lcore_scaleup_hint = rx_queue->freq_up_hint;
}

```

```

    if (lcore_scaleup_hint == FREQ_HIGHEST)
        rte_power_freq_max(lcore_id);

    else if (lcore_scaleup_hint == FREQ_HIGHER)
        rte_power_freq_up(lcore_id);
    } else {
        /**
         * All Rx queues empty in recent consecutive polls,
         * sleep in a conservative manner, meaning sleep as
         * less as possible.
         */

        for (i = 1, lcore_idle_hint = qconf->rx_queue_list[0].idle_hint; i < qconf->n_rx_queues; i++)
            rx_queue = &(qconf->rx_queue_list[i]);
            if (rx_queue->idle_hint < lcore_idle_hint)
                lcore_idle_hint = rx_queue->idle_hint;
        }

        if ( lcore_idle_hint < SLEEP_GEAR1_THRESHOLD)
            /**
             * execute "pause" instruction to avoid context
             * switch for short sleep.
             */
            rte_delay_us(lcore_idle_hint);
        else
            /* long sleep force ruining thread to suspend */
            usleep(lcore_idle_hint);

        stats[lcore_id].sleep_time += lcore_idle_hint;
    }
}
}

```

### 14.5.3 P-State Heuristic Algorithm

The `power_freq_scaleup_heuristic()` function is responsible for generating a frequency hint for the specified logical core according to available descriptor number returned from `rte_eth_rx_queue_count()`. On every poll for new packets, the length of available descriptor on an Rx queue is evaluated, and the algorithm used for frequency hinting is as follows:

- If the size of available descriptors exceeds 96, the maximum frequency is hinted.
- If the size of available descriptors exceeds 64, a trend counter is incremented by 100.
- If the length of the ring exceeds 32, the trend counter is incremented by 1.
- When the trend counter reached 10000 the frequency hint is changed to the next higher frequency.

**Note:** The assumption is that the Rx queue size is 128 and the thresholds specified above must be adjusted accordingly based on actual hardware Rx queue size, which are configured via the `rte_eth_rx_queue_setup()` function.

In general, a thread needs to poll packets from multiple Rx queues. Most likely, different queue have different load, so they would return different frequency hints. The algorithm evaluates all the hints and then scales up frequency in an aggressive manner by scaling up to highest

frequency as long as one Rx queue requires. In this way, we can minimize any negative performance impact.

On the other hand, frequency scaling down is controlled in the timer callback function. Specifically, if the sleep times of a logical core indicate that it is sleeping more than 25% of the sampling period, or if the average packet per iteration is less than expectation, the frequency is decreased by one step.

#### **14.5.4 C-State Heuristic Algorithm**

Whenever recent `rte_eth_rx_burst()` polls return 5 consecutive zero packets, an idle counter begins incrementing for each successive zero poll. At the same time, the function `power_idle_heuristic()` is called to generate speculative sleep duration in order to force logical to enter deeper sleeping C-state. There is no way to control C-state directly, and the CPUIdle subsystem in OS is intelligent enough to select C-state to enter based on actual sleep period time of giving logical core. The algorithm has the following sleeping behavior depending on the idle counter:

- If idle count less than 100, the counter value is used as a microsecond sleep value through `rte_delay_us()` which execute pause instructions to avoid costly context switch but saving power at the same time.
- If idle count is between 100 and 999, a fixed sleep interval of 100  $\mu$ s is used. A 100  $\mu$ s sleep interval allows the core to enter the C1 state while keeping a fast response time in case new traffic arrives.
- If idle count is greater than 1000, a fixed sleep value of 1 ms is used until the next timer expiration is used. This allows the core to enter the C3/C6 states.

---

**Note:** The thresholds specified above need to be adjusted for different Intel processors and traffic profiles.

---

If a thread polls multiple Rx queues and different queue returns different sleep duration values, the algorithm controls the sleep time in a conservative manner by sleeping for the least possible time in order to avoid a potential performance impact.

## L3 FORWARDING WITH ACCESS CONTROL SAMPLE APPLICATION

The L3 Forwarding with Access Control application is a simple example of packet processing using the DPDK. The application performs a security check on received packets. Packets that are in the Access Control List (ACL), which is loaded during initialization, are dropped. Others are forwarded to the correct port.

### 15.1 Overview

The application demonstrates the use of the ACL library in the DPDK to implement access control and packet L3 forwarding. The application loads two types of rules at initialization:

- Route information rules, which are used for L3 forwarding
- Access Control List (ACL) rules that blacklist (or block) packets with a specific characteristic

When packets are received from a port, the application extracts the necessary information from the TCP/IP header of the received packet and performs a lookup in the rule database to figure out whether the packets should be dropped (in the ACL range) or forwarded to desired ports. The initialization and run-time paths are similar to those of the L3 forwarding application (see Chapter 10, “L3 Forwarding Sample Application” for more information). However, there are significant differences in the two applications. For example, the original L3 forwarding application uses either LPM or an exact match algorithm to perform forwarding port lookup, while this application uses the ACL library to perform both ACL and route entry lookup. The following sections provide more detail.

Classification for both IPv4 and IPv6 packets is supported in this application. The application also assumes that all the packets it processes are TCP/UDP packets and always extracts source/destination port information from the packets.

#### 15.1.1 Tuple Packet Syntax

The application implements packet classification for the IPv4/IPv6 5-tuple syntax specifically. The 5-tuple syntax consist of a source IP address, a destination IP address, a source port, a destination port and a protocol identifier. The fields in the 5-tuple syntax have the following formats:

- **Source IP address and destination IP address** : Each is either a 32-bit field (for IPv4), or a set of 4 32-bit fields (for IPv6) represented by a value and a mask length. For

example, an IPv4 range of 192.168.1.0 to 192.168.1.255 could be represented by a value = [192, 168, 1, 0] and a mask length = 24.

- **Source port and destination port** : Each is a 16-bit field, represented by a lower start and a higher end. For example, a range of ports 0 to 8192 could be represented by lower = 0 and higher = 8192.
- **Protocol identifier** : An 8-bit field, represented by a value and a mask, that covers a range of values. To verify that a value is in the range, use the following expression: “(VAL & mask) == value”

The trick in how to represent a range with a mask and value is as follows. A range can be enumerated in binary numbers with some bits that are never changed and some bits that are dynamically changed. Set those bits that dynamically changed in mask and value with 0. Set those bits that never changed in the mask with 1, in value with number expected. For example, a range of 6 to 7 is enumerated as 0b110 and 0b111. Bit 1-7 are bits never changed and bit 0 is the bit dynamically changed. Therefore, set bit 0 in mask and value with 0, set bits 1-7 in mask with 1, and bits 1-7 in value with number 0b11. So, mask is 0xfe, value is 0x6.

---

**Note:** The library assumes that each field in the rule is in LSB or Little Endian order when creating the database. It internally converts them to MSB or Big Endian order. When performing a lookup, the library assumes the input is in MSB or Big Endian order.

---

### 15.1.2 Access Rule Syntax

In this sample application, each rule is a combination of the following:

- 5-tuple field: This field has a format described in Section.
- priority field: A weight to measure the priority of the rules. The rule with the higher priority will ALWAYS be returned if the specific input has multiple matches in the rule database. Rules with lower priority will NEVER be returned in any cases.
- userdata field: A user-defined field that could be any value. It can be the forwarding port number if the rule is a route table entry or it can be a pointer to a mapping address if the rule is used for address mapping in the NAT application. The key point is that it is a useful reserved field for user convenience.

### 15.1.3 ACL and Route Rules

The application needs to acquire ACL and route rules before it runs. Route rules are mandatory, while ACL rules are optional. To simplify the complexity of the priority field for each rule, all ACL and route entries are assumed to be in the same file. To read data from the specified file successfully, the application assumes the following:

- Each rule occupies a single line.
- Only the following four rule line types are valid in this application:
  - ACL rule line, which starts with a leading character '@'
  - Route rule line, which starts with a leading character 'R'
  - Comment line, which starts with a leading character '#'

- Empty line, which consists of a space, form-feed ('f'), newline ('n'), carriage return ('r'), horizontal tab ('t'), or vertical tab ('v').

Other lines types are considered invalid.

- Rules are organized in descending order of priority, which means rules at the head of the file always have a higher priority than those further down in the file.
- A typical IPv4 ACL rule line should have a format as shown below:

Source Address	Destination Address	Source Port	Dest Port	Protocol	
⏟		⏟		⏟	
@192.168.0.34/32		192.168.0.36/32		0 : 65535 20 : 20 6/0xfe	

Figure 15.1: A typical IPv4 ACL rule

IPv4 addresses are specified in CIDR format as specified in RFC 4632. They consist of the dot notation for the address and a prefix length separated by '/'. For example, 192.168.0.34/32, where the address is 192.168.0.34 and the prefix length is 32.

Ports are specified as a range of 16-bit numbers in the format MIN:MAX, where MIN and MAX are the inclusive minimum and maximum values of the range. The range 0:65535 represents all possible ports in a range. When MIN and MAX are the same value, a single port is represented, for example, 20:20.

The protocol identifier is an 8-bit value and a mask separated by '/'. For example: 6/0xfe matches protocol values 6 and 7.

- Route rules start with a leading character 'R' and have the same format as ACL rules except an extra field at the tail that indicates the forwarding port number.

### 15.1.4 Rules File Example

Source Address	Destination Address	Source Port	Dest Port	Protocol	Fwd
⏟		⏟		⏟	
@1.2.3.0/24		192.168.0.36/32		0 : 65535 0 : 65535 6/0xfe	
R0.0.0.0/0		192.168.0.36/32		0 : 65535 0 : 65535 6/0xfe 1	
R0.0.0.0/0		0.0.0.0/0		0 : 65535 0 : 65535 0x0/0x0 0	

Figure 15.2: Rules example

Each rule is explained as follows:

- Rule 1 (the first line) tells the application to drop those packets with source IP address = [1.2.3.\*], destination IP address = [192.168.0.36], protocol = [6]/[7]
- Rule 2 (the second line) is similar to Rule 1, except the source IP address is ignored. It tells the application to forward packets with destination IP address = [192.168.0.36], protocol = [6]/[7], destined to port 1.
- Rule 3 (the third line) tells the application to forward all packets to port 0. This is something like a default route entry.

As described earlier, the application assume rules are listed in descending order of priority, therefore Rule 1 has the highest priority, then Rule 2, and finally, Rule 3 has the lowest priority.

Consider the arrival of the following three packets:

- Packet 1 has source IP address = [1.2.3.4], destination IP address = [192.168.0.36], and protocol = [6]
- Packet 2 has source IP address = [1.2.4.4], destination IP address = [192.168.0.36], and protocol = [6]
- Packet 3 has source IP address = [1.2.3.4], destination IP address = [192.168.0.36], and protocol = [8]

Observe that:

- Packet 1 matches all of the rules
- Packet 2 matches Rule 2 and Rule 3
- Packet 3 only matches Rule 3

For priority reasons, Packet 1 matches Rule 1 and is dropped. Packet 2 matches Rule 2 and is forwarded to port 1. Packet 3 matches Rule 3 and is forwarded to port 0.

For more details on the rule file format, please refer to rule\_ipv4.db and rule\_ipv6.db files (inside <RTE\_SDK>/examples/l3fwd-acl/).

### 15.1.5 Application Phases

Once the application starts, it transitions through three phases:

- **Initialization Phase** - Perform the following tasks:
  - Parse command parameters. Check the validity of rule file(s) name(s), number of logical cores, receive and transmit queues. Bind ports, queues and logical cores. Check ACL search options, and so on.
  - Call Environmental Abstraction Layer (EAL) and Poll Mode Driver (PMD) functions to initialize the environment and detect possible NICs. The EAL creates several threads and sets affinity to a specific hardware thread CPU based on the configuration specified by the command line arguments.
  - Read the rule files and format the rules into the representation that the ACL library can recognize. Call the ACL library function to add the rules into the database and compile them as a trie of pattern sets. Note that application maintains a separate AC contexts for IPv4 and IPv6 rules.
- **Runtime Phase** - Process the incoming packets from a port. Packets are processed in three steps:
  - Retrieval: Gets a packet from the receive queue. Each logical core may process several queues for different ports. This depends on the configuration specified by command line arguments.
  - Lookup: Checks that the packet type is supported (IPv4/IPv6) and performs a 5-tuple lookup over corresponding AC context. If an ACL rule is matched, the packets will be dropped and return back to step 1. If a route rule is matched, it indicates the



packet is not in the ACL list and should be forwarded. If there is no matches for the packet, then the packet is dropped.

- Forwarding: Forwards the packet to the corresponding port.
- **Final Phase** - Perform the following tasks:
  - Calls the EAL, PMD driver and ACL library to free resource, then quits.

## 15.2 Compiling the Application

To compile the application:

1. Go to the sample application directory:

```
export RTE_SDK=/path/to/rte_sdk
cd ${RTE_SDK}/examples/l3fwd-acl
```

2. Set the target (a default target is used if not specified). For example:

```
export RTE_TARGET=x86_64-native-linuxapp-gcc
```

See the *DPDK IPL Getting Started Guide* for possible RTE\_TARGET values.

3. Build the application:

```
make
```

## 15.3 Running the Application

The application has a number of command line options:

```
./build/l3fwd-acl [EAL options] -- -p PORTMASK [-P] --config(port,queue,lcore)[,(port,queue,lcore)
```

where,

- -p PORTMASK: Hexadecimal bitmask of ports to configure
- -P: Sets all ports to promiscuous mode so that packets are accepted regardless of the packet's Ethernet MAC destination address. Without this option, only packets with the Ethernet MAC destination address set to the Ethernet address of the port are accepted.
- --config (port,queue,lcore)[,(port,queue,lcore)]: determines which queues from which ports are mapped to which cores
- --rule\_ipv4 FILENAME: Specifies the IPv4 ACL and route rules file
- --rule\_ipv6 FILENAME: Specifies the IPv6 ACL and route rules file
- --scalar: Use a scalar function to perform rule lookup
- --enable-jumbo: optional, enables jumbo frames
- --max-pkt-len: optional, maximum packet length in decimal (64-9600)
- --no-numa: optional, disables numa awareness

As an example, consider a dual processor socket platform where cores 0, 2, 4, 6, 8 and 10 appear on socket 0, while cores 1, 3, 5, 7, 9 and 11 appear on socket 1. Let's say that the user wants to use memory from both NUMA nodes, the platform has only two ports and the user wants to use two cores from each processor socket to do the packet processing.

To enable L3 forwarding between two ports, using two cores from each processor, while also taking advantage of local memory access by optimizing around NUMA, the user must enable two queues from each port, pin to the appropriate cores and allocate memory from the appropriate NUMA node. This is achieved using the following command:

```
./build/l3fwd-acl -c f -n 4 -- -p 0x3 --config="(0,0,0),(0,1,2),(1,0,1),(1,1,3)" --rule_ipv4="
```

In this command:

- The -c option enables cores 0, 1, 2, 3
- The -p option enables ports 0 and 1
- The --config option enables two queues on each port and maps each (port,queue) pair to a specific core. Logic to enable multiple RX queues using RSS and to allocate memory from the correct NUMA nodes is included in the application and is done transparently. The following table shows the mapping in this example:

Port	Queue	Icore	Description
0	0	0	Map queue 0 from port 0 to lcore 0.
0	1	2	Map queue 1 from port 0 to lcore 2.
1	0	1	Map queue 0 from port 1 to lcore 1.
1	1	3	Map queue 1 from port 1 to lcore 3.

- The --rule\_ipv4 option specifies the reading of IPv4 rules sets from the ./ rule\_ipv4.db file.
- The --rule\_ipv6 option specifies the reading of IPv6 rules sets from the ./ rule\_ipv6.db file.
- The --scalar option specifies the performing of rule lookup with a scalar function.

## 15.4 Explanation

The following sections provide some explanation of the sample application code. The aspects of port, device and CPU configuration are similar to those of the L3 forwarding application (see Chapter 10, “L3 Forwarding Sample Application” for more information). The following sections describe aspects that are specific to L3 forwarding with access control.

### 15.4.1 Parse Rules from File

As described earlier, both ACL and route rules are assumed to be saved in the same file. The application parses the rules from the file and adds them to the database by calling the ACL library function. It ignores empty and comment lines, and parses and validates the rules it reads. If errors are detected, the application exits with messages to identify the errors encountered.

The application needs to consider the userdata and priority fields. The ACL rules save the index to the specific rules in the userdata field, while route rules save the forwarding port number. In order to differentiate the two types of rules, ACL rules add a signature in the userdata field. As for the priority field, the application assumes rules are organized in descending order of priority. Therefore, the code only decreases the priority number with each rule it parses.

### 15.4.2 Setting Up the ACL Context

For each supported AC rule format (IPv4 5-tuple, IPv6 6-tuple) application creates a separate context handler from the ACL library for each CPU socket on the board and adds parsed rules into that context.

Note, that for each supported rule type, application needs to calculate the expected offset of the fields from the start of the packet. That's why only packets with fixed IPv4/ IPv6 header are supported. That allows to perform ACL classify straight over incoming packet buffer - no extra protocol field retrieval need to be performed.

Subsequently, the application checks whether NUMA is enabled. If it is, the application records the socket IDs of the CPU cores involved in the task.

Finally, the application creates contexts handler from the ACL library, adds rules parsed from the file into the database and build an ACL trie. It is important to note that the application creates an independent copy of each database for each socket CPU involved in the task to reduce the time for remote memory access.

## L3 FORWARDING IN A VIRTUALIZATION ENVIRONMENT SAMPLE APPLICATION

The L3 Forwarding in a Virtualization Environment sample application is a simple example of packet processing using the DPDK. The application performs L3 forwarding that takes advantage of Single Root I/O Virtualization (SR-IOV) features in a virtualized environment.

### 16.1 Overview

The application demonstrates the use of the hash and LPM libraries in the DPDK to implement packet forwarding. The initialization and run-time paths are very similar to those of the L3 forwarding application (see Chapter 10 “L3 Forwarding Sample Application” for more information). The forwarding decision is taken based on information read from the input packet.

The lookup method is either hash-based or LPM-based and is selected at compile time. When the selected lookup method is hash-based, a hash object is used to emulate the flow classification stage. The hash object is used in correlation with the flow table to map each input packet to its flow at runtime.

The hash lookup key is represented by the DiffServ 5-tuple composed of the following fields read from the input packet: Source IP Address, Destination IP Address, Protocol, Source Port and Destination Port. The ID of the output interface for the input packet is read from the identified flow table entry. The set of flows used by the application is statically configured and loaded into the hash at initialization time. When the selected lookup method is LPM based, an LPM object is used to emulate the forwarding stage for IPv4 packets. The LPM object is used as the routing table to identify the next hop for each input packet at runtime.

The LPM lookup key is represented by the Destination IP Address field read from the input packet. The ID of the output interface for the input packet is the next hop returned by the LPM lookup. The set of LPM rules used by the application is statically configured and loaded into the LPM object at the initialization time.

---

**Note:** Please refer to Section *Virtual Function Setup Instructions* for virtualized test case setup.

---

### 16.2 Compiling the Application

To compile the application:

1. Go to the sample application directory:

```
export RTE_SDK=/path/to/rte_sdk
cd ${RTE_SDK}/examples/l3fwd-vf
```

2. Set the target (a default target is used if not specified). For example:

```
export RTE_TARGET=x86_64-native-linuxapp-gcc
```

See the *DPDK Getting Started Guide* for possible RTE\_TARGET values.

3. Build the application:

```
make
```

**Note:** The compiled application is written to the build subdirectory. To have the application written to a different location, the `O=/path/to/build/directory` option may be specified in the make command.

## 16.3 Running the Application

The application has a number of command line options:

```
./build/l3fwd-vf [EAL options] -- -p PORTMASK --config(port,queue,lcore)[,(port,queue,lcore)]
```

where,

- `-p PORTMASK`: Hexadecimal bitmask of ports to configure
- `--config (port,queue,lcore)[,(port,queue,lcore)]`: determines which queues from which ports are mapped to which cores
- `--no-numa`: optional, disables numa awareness

For example, consider a dual processor socket platform where cores 0,2,4,6, 8, and 10 appear on socket 0, while cores 1,3,5,7,9, and 11 appear on socket 1. Let's say that the programmer wants to use memory from both NUMA nodes, the platform has only two ports and the programmer wants to use one core from each processor socket to do the packet processing since only one Rx/Tx queue pair can be used in virtualization mode.

To enable L3 forwarding between two ports, using one core from each processor, while also taking advantage of local memory accesses by optimizing around NUMA, the programmer can pin to the appropriate cores and allocate memory from the appropriate NUMA node. This is achieved using the following command:

```
./build/l3fwd-vf -c 0x03 -n 3 -- -p 0x3 --config="(0,0,0),(1,0,1)"
```

In this command:

- The `-c` option enables cores 0 and 1
- The `-p` option enables ports 0 and 1
- The `--config` option enables one queue on each port and maps each (port,queue) pair to a specific core. Logic to enable multiple RX queues using RSS and to allocate memory from the correct NUMA nodes is included in the application and is done transparently. The following table shows the mapping in this example:

Port	Queue	Icore	Description
0	0	0	Map queue 0 from port 0 to lcore 0
1	1	1	Map queue 0 from port 1 to lcore 1

Refer to the *DPDK Getting Started Guide* for general information on running applications and the Environment Abstraction Layer (EAL) options.

## 16.4 Explanation

The operation of this application is similar to that of the basic L3 Forwarding Sample Application. See Section [L3 Forwarding Explanation](#) for more information.

## LINK STATUS INTERRUPT SAMPLE APPLICATION

The Link Status Interrupt sample application is a simple example of packet processing using the Data Plane Development Kit (DPDK) that demonstrates how network link status changes for a network port can be captured and used by a DPDK application.

### 17.1 Overview

The Link Status Interrupt sample application registers a user space callback for the link status interrupt of each port and performs L2 forwarding for each packet that is received on an RX\_PORT. The following operations are performed:

- RX\_PORT and TX\_PORT are paired with available ports one-by-one according to the core mask
- The source MAC address is replaced by the TX\_PORT MAC address
- The destination MAC address is replaced by 02:00:00:00:00:TX\_PORT\_ID

This application can be used to demonstrate the usage of link status interrupt and its user space callbacks and the behavior of L2 forwarding each time the link status changes.

### 17.2 Compiling the Application

1. Go to the example directory:

```
export RTE_SDK=/path/to/rte_sdk
cd ${RTE_SDK}/examples/link_status_interrupt
```

2. Set the target (a default target is used if not specified). For example:

```
export RTE_TARGET=x86_64-native-linuxapp-gcc
```

See the *DPDK Getting Started Guide* for possible RTE\_TARGET values.

3. Build the application:

```
make
```

---

**Note:** The compiled application is written to the build subdirectory. To have the application written to a different location, the `O=/path/to/build/directory` option may be specified on the make command line.

---

## 17.3 Running the Application

The application requires a number of command line options:

```
./build/link_status_interrupt [EAL options] -- -p PORTMASK [-q NQ][-T PERIOD]
```

where,

- -p PORTMASK: A hexadecimal bitmask of the ports to configure
- -q NQ: A number of queues (=ports) per lcore (default is 1)
- -T PERIOD: statistics will be refreshed each PERIOD seconds (0 to disable, 10 default)

To run the application in a linuxapp environment with 4 lcores, 4 memory channels, 16 ports and 8 RX queues per lcore, issue the command:

```
$ ./build/link_status_interrupt -c f -n 4-- -q 8 -p ffff
```

Refer to the *DPDK Getting Started Guide* for general information on running applications and the Environment Abstraction Layer (EAL) options.

## 17.4 Explanation

The following sections provide some explanation of the code.

### 17.4.1 Command Line Arguments

The Link Status Interrupt sample application takes specific parameters, in addition to Environment Abstraction Layer (EAL) arguments (see Section *Running the Application*).

Command line parsing is done in the same way as it is done in the L2 Forwarding Sample Application. See Section *Command Line Arguments* for more information.

### 17.4.2 Mbuf Pool Initialization

Mbuf pool initialization is done in the same way as it is done in the L2 Forwarding Sample Application. See Section *Mbuf Pool Initialization* for more information.

### 17.4.3 Driver Initialization

The main part of the code in the main() function relates to the initialization of the driver. To fully understand this code, it is recommended to study the chapters that related to the Poll Mode Driver in the *DPDK Programmer's Guide and the DPDK API Reference*.

```
if (rte_eal_pci_probe() < 0)
    rte_exit(EXIT_FAILURE, "Cannot probe PCI\n");

nb_ports = rte_eth_dev_count();
if (nb_ports == 0)
    rte_exit(EXIT_FAILURE, "No Ethernet ports - bye\n");

if (nb_ports > RTE_MAX_ETHPORTS)
```



```

    nb_ports = RTE_MAX_ETHPORTS;

    /*
     * Each logical core is assigned a dedicated TX queue on each port.
     */

    for (portid = 0; portid < nb_ports; portid++) {
        /* skip ports that are not enabled */

        if ((lsi_enabled_port_mask & (1 << portid)) == 0)
            continue;

        /* save the destination port id */

        if (nb_ports_in_mask % 2) {
            lsi_dst_ports[portid] = portid_last;
            lsi_dst_ports[portid_last] = portid;
        }
        else
            portid_last = portid;

        nb_ports_in_mask++;

        rte_eth_dev_info_get((uint8_t) portid, &dev_info);
    }

```

Observe that:

- `rte_eal_pci_probe()` parses the devices on the PCI bus and initializes recognized devices.

The next step is to configure the RX and TX queues. For each port, there is only one RX queue (only one lcore is able to poll a given port). The number of TX queues depends on the number of available lcores. The `rte_eth_dev_configure()` function is used to configure the number of queues for a port:

```

ret = rte_eth_dev_configure((uint8_t) portid, 1, 1, &port_conf);
if (ret < 0)
    rte_exit(EXIT_FAILURE, "Cannot configure device: err=%d, port=%u\n", ret, portid);

```

The global configuration is stored in a static structure:

```

static const struct rte_eth_conf port_conf = {
    .rxmode = {
        .split_hdr_size = 0,
        .header_split = 0, /**< Header Split disabled */
        .hw_ip_checksum = 0, /**< IP checksum offload disabled */
        .hw_vlan_filter = 0, /**< VLAN filtering disabled */
        .hw_strip_crc = 0, /**< CRC stripped by hardware */
    },
    .txmode = {},
    .intr_conf = {
        .lsc = 1, /**< link status interrupt feature enabled */
    },
};

```

Configuring `lsc` to 0 (the default) disables the generation of any link status change interrupts in kernel space and no user space interrupt event is received. The public interface `rte_eth_link_get()` accesses the NIC registers directly to update the link status. Configuring `lsc` to non-zero enables the generation of link status change interrupts in kernel space when a link status change is present and calls the user space callbacks registered by the application.

The public interface `rte_eth_link_get()` just reads the link status in a global structure that would be updated in the interrupt host thread only.

#### 17.4.4 Interrupt Callback Registration

The application can register one or more callbacks to a specific port and interrupt event. An example callback function that has been written as indicated below.

```
static void
lsi_event_callback(uint8_t port_id, enum rte_eth_event_type type, void *param)
{
    struct rte_eth_link link;

    RTE_SET_USED(param);

    printf("\n\nIn registered callback...\n");

    printf("Event type: %s\n", type == RTE_ETH_EVENT_INTR_LSC ? "LSC interrupt" : "unknown event");

    rte_eth_link_get_nowait(port_id, &link);

    if (link.link_status) {
        printf("Port %d Link Up - speed %u Mbps - %s\n\n", port_id, (unsigned)link.link_speed,
              (link.link_duplex == ETH_LINK_FULL_DUPLEX) ? ("full-duplex") : ("half-duplex"));
    } else
        printf("Port %d Link Down\n\n", port_id);
}
```

This function is called when a link status interrupt is present for the right port. The `port_id` indicates which port the interrupt applies to. The type parameter identifies the interrupt event type, which currently can be `RTE_ETH_EVENT_INTR_LSC` only, but other types can be added in the future. The `param` parameter is the address of the parameter for the callback. This function should be implemented with care since it will be called in the interrupt host thread, which is different from the main thread of its caller.

The application registers the `lsi_event_callback` and a NULL parameter to the link status interrupt event on each port:

```
rte_eth_dev_callback_register((uint8_t)portid, RTE_ETH_EVENT_INTR_LSC, lsi_event_callback, NULL);
```

This registration can be done only after calling the `rte_eth_dev_configure()` function and before calling any other function. If `lsc` is initialized with 0, the callback is never called since no interrupt event would ever be present.

#### 17.4.5 RX Queue Initialization

The application uses one lcore to poll one or several ports, depending on the `-q` option, which specifies the number of queues per lcore.

For example, if the user specifies `-q 4`, the application is able to poll four ports with one lcore. If there are 16 ports on the target (and if the `portmask` argument is `-p ffff`), the application will need four lcores to poll all the ports.

```
ret = rte_eth_rx_queue_setup((uint8_t) portid, 0, nb_rxd, SOCKET0, &rx_conf, lsi_pktmbuf_pool);
if (ret < 0)
    rte_exit(EXIT_FAILURE, "rte_eth_rx_queue_setup: err=%d, port=%u\n", ret, portid);
```

The list of queues that must be polled for a given lcore is stored in a private structure called `struct lcore_queue_conf`.

```

struct lcore_queue_conf {
    unsigned n_rx_port;
    unsigned rx_port_list[MAX_RX_QUEUE_PER_LCORE]; unsigned tx_queue_id;
    struct mbuf_table tx_mbufs[LSI_MAX_PORTS];
} rte_cache_aligned;

struct lcore_queue_conf lcore_queue_conf[RTE_MAX_LCORE];

```

The `n_rx_port` and `rx_port_list[]` fields are used in the main packet processing loop (see the “Receive, Process and Transmit Packets” section below).

The global configuration for the RX queues is stored in a static structure:

```

static const struct rte_eth_rxconf rx_conf = {
    .rx_thresh = {
        .pthresh = RX_PTHRESH,
        .hthresh = RX_HTHRESH,
        .wthresh = RX_WTHRESH,
    },
};

```

### 17.4.6 TX Queue Initialization

Each lcore should be able to transmit on any port. For every port, a single TX queue is initialized.

```

/* init one TX queue logical core on each port */

fflush(stdout);

ret = rte_eth_tx_queue_setup(portid, 0, nb_txd, rte_eth_dev_socket_id(portid), &tx_conf);
if (ret < 0)
    rte_exit(EXIT_FAILURE, "rte_eth_tx_queue_setup: err=%d,port=%u\n", ret, (unsigned) portid)

```

The global configuration for TX queues is stored in a static structure:

```

static const struct rte_eth_txconf tx_conf = {
    .tx_thresh = {
        .pthresh = TX_PTHRESH,
        .hthresh = TX_HTHRESH,
        .wthresh = TX_WTHRESH,
    },
    .tx_free_thresh = RTE_TEST_TX_DESC_DEFAULT + 1, /* disable feature */
};

```

### 17.4.7 Receive, Process and Transmit Packets

In the `lcore_main_loop()` function, the main task is to read ingress packets from the RX queues. This is done using the following code:

```

/*
 * Read packet from RX queues
 */

for (i = 0; i < qconf->n_rx_port; i++) {

```

```

portid = qconf->rx_port_list[i];
nb_rx = rte_eth_rx_burst((uint8_t) portid, 0, pkts_burst, MAX_PKT_BURST);
port_statistics[portid].rx += nb_rx;

for (j = 0; j < nb_rx; j++) {
    m = pkts_burst[j];
    rte_prefetch0(rte_pktmbuf_mtod(m, void *));
    lsi_simple_forward(m, portid);
}
}

```

Packets are read in a burst of size MAX\_PKT\_BURST. The `rte_eth_rx_burst()` function writes the mbuf pointers in a local table and returns the number of available mbufs in the table.

Then, each mbuf in the table is processed by the `lsi_simple_forward()` function. The processing is very simple: processes the TX port from the RX port and then replaces the source and destination MAC addresses.

**Note:** In the following code, the two lines for calculating the output port require some explanation. If `portid` is even, the first line does nothing (as `portid & 1` will be 0), and the second line adds 1. If `portid` is odd, the first line subtracts one and the second line does nothing. Therefore, 0 goes to 1, and 1 to 0, 2 goes to 3 and 3 to 2, and so on.

```

static void
lsi_simple_forward(struct rte_mbuf *m, unsigned portid)
{
    struct ether_hdr *eth;
    void *tmp;
    unsigned dst_port = lsi_dst_ports[portid];

    eth = rte_pktmbuf_mtod(m, struct ether_hdr *);

    /* 02:00:00:00:00:xx */
    tmp = &eth->d_addr.addr_bytes[0];

    *((uint64_t *)tmp) = 0x0000000000002 + (dst_port << 40);

    /* src addr */
    ether_addr_copy(&lsi_ports_eth_addr[dst_port], &eth->s_addr);

    lsi_send_packet(m, dst_port);
}

```

Then, the packet is sent using the `lsi_send_packet(m, dst_port)` function. For this test application, the processing is exactly the same for all packets arriving on the same RX port. Therefore, it would have been possible to call the `lsi_send_burst()` function directly from the main loop to send all the received packets on the same TX port using the burst-oriented send function, which is more efficient.

However, in real-life applications (such as, L3 routing), packet N is not necessarily forwarded on the same port as packet N-1. The application is implemented to illustrate that so the same approach can be reused in a more complex application.

The `lsi_send_packet()` function stores the packet in a per-core and per-txport table. If the table is full, the whole packets table is transmitted using the `lsi_send_burst()` function:

```

/* Send the packet on an output interface */

```

```

static int
lsi_send_packet(struct rte_mbuf *m, uint8_t port)
{
    unsigned lcore_id, len;
    struct lcore_queue_conf *qconf;

    lcore_id = rte_lcore_id();
    qconf = &lcore_queue_conf[lcore_id];
    len = qconf->tx_mbufs[port].len;
    qconf->tx_mbufs[port].m_table[len] = m;
    len++;

    /* enough pkts to be sent */

    if (unlikely(len == MAX_PKT_BURST)) {
        lsi_send_burst(qconf, MAX_PKT_BURST, port);
        len = 0;
    }
    qconf->tx_mbufs[port].len = len;

    return 0;
}

```

To ensure that no packets remain in the tables, each lcore does a draining of the TX queue in its main loop. This technique introduces some latency when there are not many packets to send. However, it improves performance:

```

cur_tsc = rte_rdtsc();

/*
 *   TX burst queue drain
 */

diff_tsc = cur_tsc - prev_tsc;

if (unlikely(diff_tsc > drain_tsc)) {
    /* this could be optimized (use queueid instead of * portid), but it is not called so oft

    for (portid = 0; portid < RTE_MAX_ETHPORTS; portid++) {
        if (qconf->tx_mbufs[portid].len == 0)
            continue;

        lsi_send_burst(&lcore_queue_conf[lcore_id],
            qconf->tx_mbufs[portid].len, (uint8_t) portid);
        qconf->tx_mbufs[portid].len = 0;
    }

    /* if timer is enabled */

    if (timer_period > 0) {
        /* advance the timer */

        timer_tsc += diff_tsc;

        /* if timer has reached its timeout */

        if (unlikely(timer_tsc >= (uint64_t) timer_period)) {
            /* do this only on master core */

            if (lcore_id == rte_get_master_lcore()) {
                print_stats();
            }
        }
    }
}

```

```
        /* reset the timer */
        timer_tsc = 0;
    }
}
prev_tsc = cur_tsc;
}
```

## LOAD BALANCER SAMPLE APPLICATION

The Load Balancer sample application demonstrates the concept of isolating the packet I/O task from the application-specific workload. Depending on the performance target, a number of logical cores (lcores) are dedicated to handle the interaction with the NIC ports (I/O lcores), while the rest of the lcores are dedicated to performing the application processing (worker lcores). The worker lcores are totally oblivious to the intricacies of the packet I/O activity and use the NIC-agnostic interface provided by software rings to exchange packets with the I/O cores.

### 18.1 Overview

The architecture of the Load Balance application is presented in the following figure.

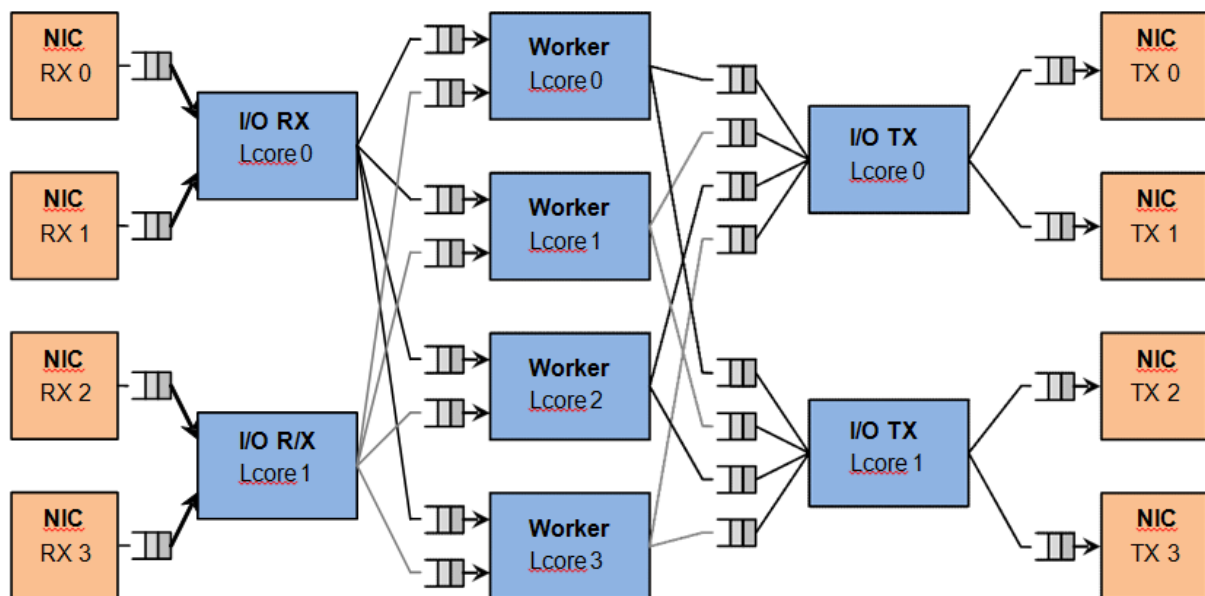

Figure 18.1: Load Balancer Application Architecture

For the sake of simplicity, the diagram illustrates a specific case of two I/O RX and two I/O TX lcores off loading the packet I/O overhead incurred by four NIC ports from four worker cores, with each I/O lcore handling RX/TX for two NIC ports.

### 18.1.1 I/O RX Logical Cores

Each I/O RX lcore performs packet RX from its assigned NIC RX rings and then distributes the received packets to the worker threads. The application allows each I/O RX lcore to communicate with any of the worker threads, therefore each (I/O RX lcore, worker lcore) pair is connected through a dedicated single producer - single consumer software ring.

The worker lcore to handle the current packet is determined by reading a predefined 1-byte field from the input packet:

```
worker_id = packet[load_balancing_field] % n_workers
```

Since all the packets that are part of the same traffic flow are expected to have the same value for the load balancing field, this scheme also ensures that all the packets that are part of the same traffic flow are directed to the same worker lcore (flow affinity) in the same order they enter the system (packet ordering).

### 18.1.2 I/O TX Logical Cores

Each I/O lcore owns the packet TX for a predefined set of NIC ports. To enable each worker thread to send packets to any NIC TX port, the application creates a software ring for each (worker lcore, NIC TX port) pair, with each I/O TX core handling those software rings that are associated with NIC ports that it handles.

### 18.1.3 Worker Logical Cores

Each worker lcore reads packets from its set of input software rings and routes them to the NIC ports for transmission by dispatching them to output software rings. The routing logic is LPM based, with all the worker threads sharing the same LPM rules.

## 18.2 Compiling the Application

The sequence of steps used to build the application is:

1. Export the required environment variables:

```
export RTE_SDK=<Path to the DPDK installation folder>
export RTE_TARGET=x86_64-native-linuxapp-gcc
```

2. Build the application executable file:

```
cd ${RTE_SDK}/examples/load_balancer make
```

For more details on how to build the DPDK libraries and sample applications, please refer to the *DPDK Getting Started Guide*.

## 18.3 Running the Application

To successfully run the application, the command line used to start the application has to be in sync with the traffic flows configured on the traffic generator side.



For examples of application command lines and traffic generator flows, please refer to the DPDK Test Report. For more details on how to set up and run the sample applications provided with DPDK package, please refer to the *DPDK Getting Started Guide*.

## 18.4 Explanation

### 18.4.1 Application Configuration

The application run-time configuration is done through the application command line parameters. Any parameter that is not specified as mandatory is optional, with the default value hard-coded in the main.h header file from the application folder.

The list of application command line parameters is listed below:

1. `-rx` "(PORT, QUEUE, LCORE), ...": The list of NIC RX ports and queues handled by the I/O RX lcores. This parameter also implicitly defines the list of I/O RX lcores. This is a mandatory parameter.
2. `-tx` "(PORT, LCORE), ... ": The list of NIC TX ports handled by the I/O TX lcores. This parameter also implicitly defines the list of I/O TX lcores. This is a mandatory parameter.
3. `-w` "LCORE, ...": The list of the worker lcores. This is a mandatory parameter.
4. `-lpm` "IP / PREFIX => PORT; ...": The list of LPM rules used by the worker lcores for packet forwarding. This is a mandatory parameter.
5. `-rsz` "A, B, C, D": Ring sizes:
  - (a) A = The size (in number of buffer descriptors) of each of the NIC RX rings read by the I/O RX lcores.
  - (b) B = The size (in number of elements) of each of the software rings used by the I/O RX lcores to send packets to worker lcores.
  - (c) C = The size (in number of elements) of each of the software rings used by the worker lcores to send packets to I/O TX lcores.
  - (d) D = The size (in number of buffer descriptors) of each of the NIC TX rings written by I/O TX lcores.
6. `-bsz` "(A, B), (C, D), (E, F)": Burst sizes:
  - (a) A = The I/O RX lcore read burst size from NIC RX.
  - (b) B = The I/O RX lcore write burst size to the output software rings.
  - (c) C = The worker lcore read burst size from the input software rings.
  - (d) D = The worker lcore write burst size to the output software rings.
  - (e) E = The I/O TX lcore read burst size from the input software rings.
  - (f) F = The I/O TX lcore write burst size to the NIC TX.
7. `-pos-lb` POS: The position of the 1-byte field within the input packet used by the I/O RX lcores to identify the worker lcore for the current packet. This field needs to be within the first 64 bytes of the input packet.

The infrastructure of software rings connecting I/O lcores and worker lcores is built by the application as a result of the application configuration provided by the user through the application command line parameters.

A specific lcore performing the I/O RX role for a specific set of NIC ports can also perform the I/O TX role for the same or a different set of NIC ports. A specific lcore cannot perform both the I/O role (either RX or TX) and the worker role during the same session.

Example:

```
./load_balancer -c 0xf8 -n 4 -- --rx "(0,0,3),(1,0,3)" --tx "(0,3),(1,3)" --w "4,5,6,7" --lpm
```

There is a single I/O lcore (lcore 3) that handles RX and TX for two NIC ports (ports 0 and 1) that handles packets to/from four worker lcores (lcores 4, 5, 6 and 7) that are assigned worker IDs 0 to 3 (worker ID for lcore 4 is 0, for lcore 5 is 1, for lcore 6 is 2 and for lcore 7 is 3).

Assuming that all the input packets are IPv4 packets with no VLAN label and the source IP address of the current packet is A.B.C.D, the worker lcore for the current packet is determined by byte D (which is byte 29). There are two LPM rules that are used by each worker lcore to route packets to the output NIC ports.

The following table illustrates the packet flow through the system for several possible traffic flows:

Flow #	Source IP Address	Destination IP Address	Worker ID (Worker lcore)	Output NIC Port
1	0.0.0.0	1.0.0.1	0 (4)	0
2	0.0.0.1	1.0.1.2	1 (5)	1
3	0.0.0.14	1.0.0.3	2 (6)	0
4	0.0.0.15	1.0.1.4	3 (7)	1

### 18.4.2 NUMA Support

The application has built-in performance enhancements for the NUMA case:

1. One buffer pool per each CPU socket.
2. One LPM table per each CPU socket.
3. Memory for the NIC RX or TX rings is allocated on the same socket with the lcore handling the respective ring.

In the case where multiple CPU sockets are used in the system, it is recommended to enable at least one lcore to fulfill the I/O role for the NIC ports that are directly attached to that CPU socket through the PCI Express\* bus. It is always recommended to handle the packet I/O with lcores from the same CPU socket as the NICs.

Depending on whether the I/O RX lcore (same CPU socket as NIC RX), the worker lcore and the I/O TX lcore (same CPU socket as NIC TX) handling a specific input packet, are on the same or different CPU sockets, the following run-time scenarios are possible:

1. AAA: The packet is received, processed and transmitted without going across CPU sockets.
2. AAB: The packet is received and processed on socket A, but as it has to be transmitted on a NIC port connected to socket B, the packet is sent to socket B through software rings.

3. ABB: The packet is received on socket A, but as it has to be processed by a worker lcore on socket B, the packet is sent to socket B through software rings. The packet is transmitted by a NIC port connected to the same CPU socket as the worker lcore that processed it.
4. ABC: The packet is received on socket A, it is processed by an lcore on socket B, then it has to be transmitted out by a NIC connected to socket C. The performance price for crossing the CPU socket boundary is paid twice for this packet.

## MULTI-PROCESS SAMPLE APPLICATION

This chapter describes the example applications for multi-processing that are included in the DPDK.

### 19.1 Example Applications

#### 19.1.1 Building the Sample Applications

The multi-process example applications are built in the same way as other sample applications, and as documented in the *DPDK Getting Started Guide*. To build all the example applications:

1. Set RTE\_SDK and go to the example directory:

```
export RTE_SDK=/path/to/rte_sdk
cd ${RTE_SDK}/examples/multi_process
```

2. Set the target (a default target will be used if not specified). For example:

```
export RTE_TARGET=x86_64-native-linuxapp-gcc
```

See the *DPDK Getting Started Guide* for possible RTE\_TARGET values.

3. Build the applications:

```
make
```

---

**Note:** If just a specific multi-process application needs to be built, the final make command can be run just in that application's directory, rather than at the top-level multi-process directory.

---

#### 19.1.2 Basic Multi-process Example

The examples/simple\_mp folder in the DPDK release contains a basic example application to demonstrate how two DPDK processes can work together using queues and memory pools to share information.

#### Running the Application

To run the application, start one copy of the simple\_mp binary in one terminal, passing at least two cores in the coremask, as follows:

```
./build/simple_mp -c 3 -n 4 --proc-type=primary
```

For the first DPDK process run, the proc-type flag can be omitted or set to auto, since all DPDK processes will default to being a primary instance, meaning they have control over the hugepage shared memory regions. The process should start successfully and display a command prompt as follows:

```
$ ./build/simple_mp -c 3 -n 4 --proc-type=primary
EAL: coremask set to 3
EAL: Detected lcore 0 on socket 0
EAL: Detected lcore 1 on socket 0
EAL: Detected lcore 2 on socket 0
EAL: Detected lcore 3 on socket 0
...
EAL: Requesting 2 pages of size 1073741824
EAL: Requesting 768 pages of size 2097152
EAL: Ask a virtual area of 0x40000000 bytes
EAL: Virtual area found at 0x7ff200000000 (size = 0x40000000)
...
EAL: check igb_uio module
EAL: check module finished
EAL: Master core 0 is ready (tid=54e41820)
EAL: Core 1 is ready (tid=53b32700)

Starting core 1

simple_mp >
```

To run the secondary process to communicate with the primary process, again run the same binary setting at least two cores in the coremask:

```
./build/simple_mp -c C -n 4 --proc-type=secondary
```

When running a secondary process such as that shown above, the proc-type parameter can again be specified as auto. However, omitting the parameter altogether will cause the process to try and start as a primary rather than secondary process.

Once the process type is specified correctly, the process starts up, displaying largely similar status messages to the primary instance as it initializes. Once again, you will be presented with a command prompt.

Once both processes are running, messages can be sent between them using the send command. At any stage, either process can be terminated using the quit command.

EAL: Master core 10 is ready (tid=b5f89820)	EAL: Master core 8 is ready (tid=864a382)
EAL: Core 11 is ready (tid=84ffe700)	EAL: Core 9 is ready (tid=85995700)
Starting core 11	Starting core 9
simple_mp > send hello_secondary	simple_mp > core 9: Received 'hello_sec
simple_mp > core 11: Received 'hello_primary'	simple_mp > send hello_primary
simple_mp > quit	simple_mp > quit

**Note:** If the primary instance is terminated, the secondary instance must also be shut-down and restarted after the primary. This is necessary because the primary instance will clear and reset the shared memory regions on startup, invalidating the secondary process's pointers. The secondary process can be stopped and restarted without affecting the primary process.

## How the Application Works

The core of this example application is based on using two queues and a single memory pool in shared memory. These three objects are created at startup by the primary process, since the secondary process cannot create objects in memory as it cannot reserve memory zones, and the secondary process then uses lookup functions to attach to these objects as it starts up.

```

if (rte_eal_process_type() == RTE_PROC_PRIMARY){
    send_ring = rte_ring_create(_PRI_2_SEC, ring_size, SOCKET0, flags);
    rcv_ring = rte_ring_create(_SEC_2_PRI, ring_size, SOCKET0, flags);
    message_pool = rte_mempool_create(_MSG_POOL, pool_size, string_size, pool_cache, priv_data
} else {
    rcv_ring = rte_ring_lookup(_PRI_2_SEC);
    send_ring = rte_ring_lookup(_SEC_2_PRI);
    message_pool = rte_mempool_lookup(_MSG_POOL);
}

```

Note, however, that the named ring structure used as `send_ring` in the primary process is the `rcv_ring` in the secondary process.

Once the rings and memory pools are all available in both the primary and secondary processes, the application simply dedicates two threads to sending and receiving messages respectively. The receive thread simply dequeues any messages on the receive ring, prints them, and frees the buffer space used by the messages back to the memory pool. The send thread makes use of the command-prompt library to interactively request user input for messages to send. Once a send command is issued by the user, a buffer is allocated from the memory pool, filled in with the message contents, then enqueued on the appropriate `rte_ring`.

### 19.1.3 Symmetric Multi-process Example

The second example of DPDK multi-process support demonstrates how a set of processes can run in parallel, with each process performing the same set of packet-processing operations. (Since each process is identical in functionality to the others, we refer to this as symmetric multi-processing, to differentiate it from asymmetric multi-processing - such as a client-server mode of operation seen in the next example, where different processes perform different tasks, yet co-operate to form a packet-processing system.) The following diagram shows the data-flow through the application, using two processes.

As the diagram shows, each process reads packets from each of the network ports in use. RSS is used to distribute incoming packets on each port to different hardware RX queues. Each process reads a different RX queue on each port and so does not contend with any other process for that queue access. Similarly, each process writes outgoing packets to a different TX queue on each port.

## Running the Application

As with the `simple_mp` example, the first instance of the `symmetric_mp` process must be run as the primary instance, though with a number of other application-specific parameters also provided after the EAL arguments. These additional parameters are:

- `-p <portmask>`, where `portmask` is a hexadecimal bitmask of what ports on the system are to be used. For example: `-p 3` to use ports 0 and 1 only.

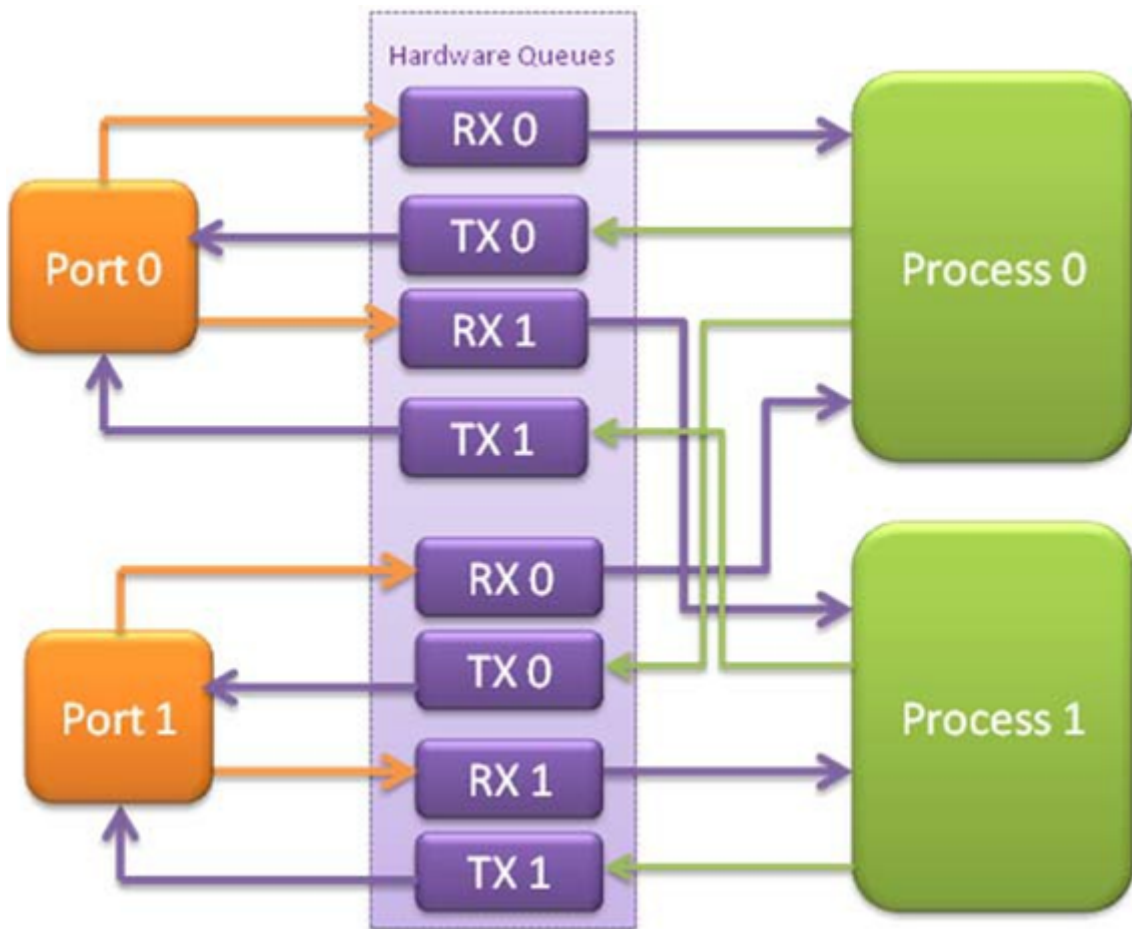

Figure 19.1: Example Data Flow in a Symmetric Multi-process Application

- `--num-procs <N>`, where N is the total number of `symmetric_mp` instances that will be run side-by-side to perform packet processing. This parameter is used to configure the appropriate number of receive queues on each network port.
- `--proc-id <n>`, where n is a numeric value in the range  $0 \leq n < N$  (number of processes, specified above). This identifies which `symmetric_mp` instance is being run, so that each process can read a unique receive queue on each network port.

The secondary `symmetric_mp` instances must also have these parameters specified, and the first two must be the same as those passed to the primary instance, or errors result.

For example, to run a set of four `symmetric_mp` instances, running on lcores 1-4, all performing level-2 forwarding of packets between ports 0 and 1, the following commands can be used (assuming run as root):

```
# ./build/symmetric_mp -c 2 -n 4 --proc-type=auto -- -p 3 --num-procs=4 --proc-id=0
# ./build/symmetric_mp -c 4 -n 4 --proc-type=auto -- -p 3 --num-procs=4 --proc-id=1
# ./build/symmetric_mp -c 8 -n 4 --proc-type=auto -- -p 3 --num-procs=4 --proc-id=2
# ./build/symmetric_mp -c 10 -n 4 --proc-type=auto -- -p 3 --num-procs=4 --proc-id=3
```

**Note:** In the above example, the process type can be explicitly specified as primary or secondary, rather than auto. When using auto, the first process run creates all the memory structures needed for all processes - irrespective of whether it has a `proc-id` of 0, 1, 2 or 3.

**Note:** For the symmetric multi-process example, since all processes work in the same manner, once the hugepage shared memory and the network ports are initialized, it is not necessary to restart all processes if the primary instance dies. Instead, that process can be restarted as a secondary, by explicitly setting the `proc-type` to secondary on the command line. (All subsequent instances launched will also need this explicitly specified, as auto-detection will detect no primary processes running and therefore attempt to re-initialize shared memory.)

## How the Application Works

The initialization calls in both the primary and secondary instances are the same for the most part, calling the `rte_eal_init()`, 1 G and 10 G driver initialization and then `rte_eal_pci_probe()` functions. Thereafter, the initialization done depends on whether the process is configured as a primary or secondary instance.

In the primary instance, a memory pool is created for the packet mbufs and the network ports to be used are initialized - the number of RX and TX queues per port being determined by the `num-procs` parameter passed on the command-line. The structures for the initialized network ports are stored in shared memory and therefore will be accessible by the secondary process as it initializes.

```
if (num_ports & 1)
    rte_exit(EXIT_FAILURE, "Application must use an even number of ports\n");

for(i = 0; i < num_ports; i++){
    if(proc_type == RTE_PROC_PRIMARY)
        if (smp_port_init(ports[i], mp, (uint16_t)num_procs) < 0)
            rte_exit(EXIT_FAILURE, "Error initializing ports\n");
}
```



In the secondary instance, rather than initializing the network ports, the port information exported by the primary process is used, giving the secondary process access to the hardware and software rings for each network port. Similarly, the memory pool of mbufs is accessed by doing a lookup for it by name:

```
mp = (proc_type == RTE_PROC_SECONDARY) ? rte_mempool_lookup(_SMP_MBUF_POOL) : rte_mempool_crea
```

Once this initialization is complete, the main loop of each process, both primary and secondary, is exactly the same - each process reads from each port using the queue corresponding to its proc-id parameter, and writes to the corresponding transmit queue on the output port.

### 19.1.4 Client-Server Multi-process Example

The third example multi-process application included with the DPDK shows how one can use a client-server type multi-process design to do packet processing. In this example, a single server process performs the packet reception from the ports being used and distributes these packets using round-robin ordering among a set of client processes, which perform the actual packet processing. In this case, the client applications just perform level-2 forwarding of packets by sending each packet out on a different network port.

The following diagram shows the data-flow through the application, using two client processes.

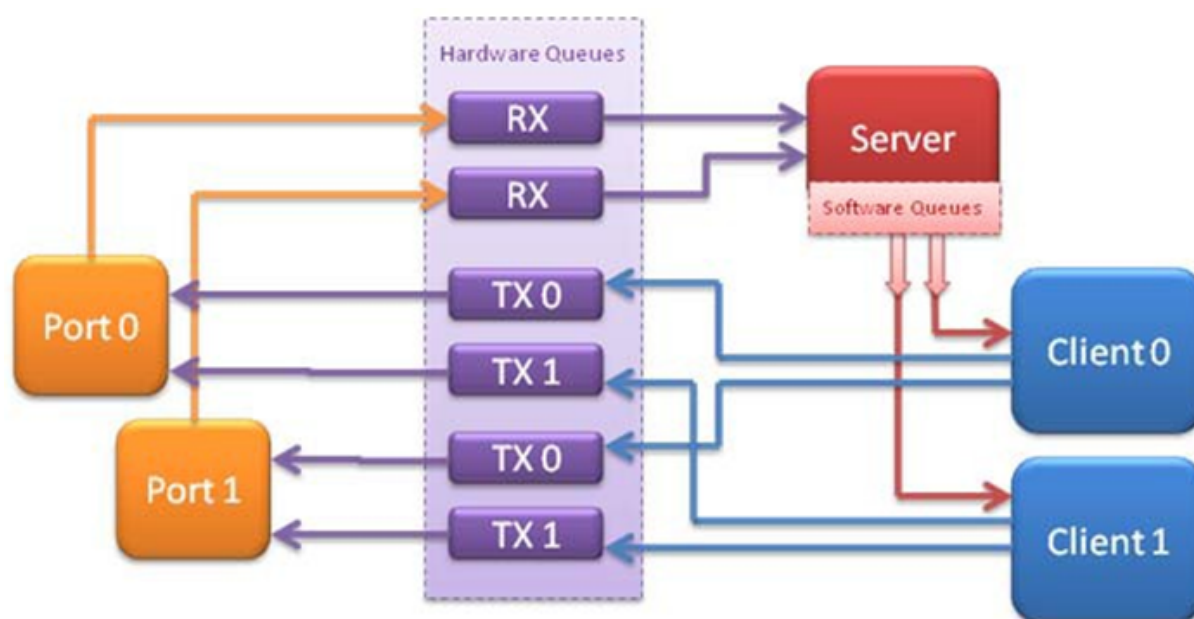

Figure 19.2: Example Data Flow in a Client-Server Symmetric Multi-process Application

### Running the Application

The server process must be run initially as the primary process to set up all memory structures for use by the clients. In addition to the EAL parameters, the application-specific parameters are:

- `-p <portmask >`, where portmask is a hexadecimal bitmask of what ports on the system are to be used. For example: `-p 3` to use ports 0 and 1 only.

- `-n <num-clients>`, where the `num-clients` parameter is the number of client processes that will process the packets received by the server application.

---

**Note:** In the server process, a single thread, the master thread, that is, the lowest numbered lcore in the `coremask`, performs all packet I/O. If a `coremask` is specified with more than a single lcore bit set in it, an additional lcore will be used for a thread to periodically print packet count statistics.

---

Since the server application stores configuration data in shared memory, including the network ports to be used, the only application parameter needed by a client process is its client instance ID. Therefore, to run a server application on lcore 1 (with lcore 2 printing statistics) along with two client processes running on lcores 3 and 4, the following commands could be used:

```
# ./mp_server/build/mp_server -c 6 -n 4 -- -p 3 -n 2
# ./mp_client/build/mp_client -c 8 -n 4 --proc-type=auto -- -n 0
# ./mp_client/build/mp_client -c 10 -n 4 --proc-type=auto -- -n 1
```

---

**Note:** If the server application dies and needs to be restarted, all client applications also need to be restarted, as there is no support in the server application for it to run as a secondary process. Any client processes that need restarting can be restarted without affecting the server process.

---

## How the Application Works

The server process performs the network port and data structure initialization much as the symmetric multi-process application does when run as primary. One additional enhancement in this sample application is that the server process stores its port configuration data in a memory zone in hugepage shared memory. This eliminates the need for the client processes to have the `portmask` parameter passed into them on the command line, as is done for the symmetric multi-process application, and therefore eliminates mismatched parameters as a potential source of errors.

In the same way that the server process is designed to be run as a primary process instance only, the client processes are designed to be run as secondary instances only. They have no code to attempt to create shared memory objects. Instead, handles to all needed rings and memory pools are obtained via calls to `rte_ring_lookup()` and `rte_mempool_lookup()`. The network ports for use by the processes are obtained by loading the network port drivers and probing the PCI bus, which will, as in the symmetric multi-process example, automatically get access to the network ports using the settings already configured by the primary/server process.

Once all applications are initialized, the server operates by reading packets from each network port in turn and distributing those packets to the client queues (software rings, one for each client process) in round-robin order. On the client side, the packets are read from the rings in as big of bursts as possible, then routed out to a different network port. The routing used is very simple. All packets received on the first NIC port are transmitted back out on the second port and vice versa. Similarly, packets are routed between the 3rd and 4th network ports and so on. The sending of packets is done by writing the packets directly to the network ports; they are not transferred back via the server process.

In both the server and the client processes, outgoing packets are buffered before being sent, so as to allow the sending of multiple packets in a single burst to improve efficiency. For example,

the client process will buffer packets to send, until either the buffer is full or until we receive no further packets from the server.

### 19.1.5 Master-slave Multi-process Example

The fourth example of DPDK multi-process support demonstrates a master-slave model that provide the capability of application recovery if a slave process crashes or meets unexpected conditions. In addition, it also demonstrates the floating process, which can run among different cores in contrast to the traditional way of binding a process/thread to a specific CPU core, using the local cache mechanism of mempool structures.

This application performs the same functionality as the L2 Forwarding sample application, therefore this chapter does not cover that part but describes functionality that is introduced in this multi-process example only. Please refer to Chapter 9, “L2 Forwarding Sample Application (in Real and Virtualized Environments)” for more information.

Unlike previous examples where all processes are started from the command line with input arguments, in this example, only one process is spawned from the command line and that process creates other processes. The following section describes this in more detail.

#### Master-slave Process Models

The process spawned from the command line is called the *master process* in this document. A process created by the master is called a *slave process*. The application has only one master process, but could have multiple slave processes.

Once the master process begins to run, it tries to initialize all the resources such as memory, CPU cores, driver, ports, and so on, as the other examples do. Thereafter, it creates slave processes, as shown in the following figure.

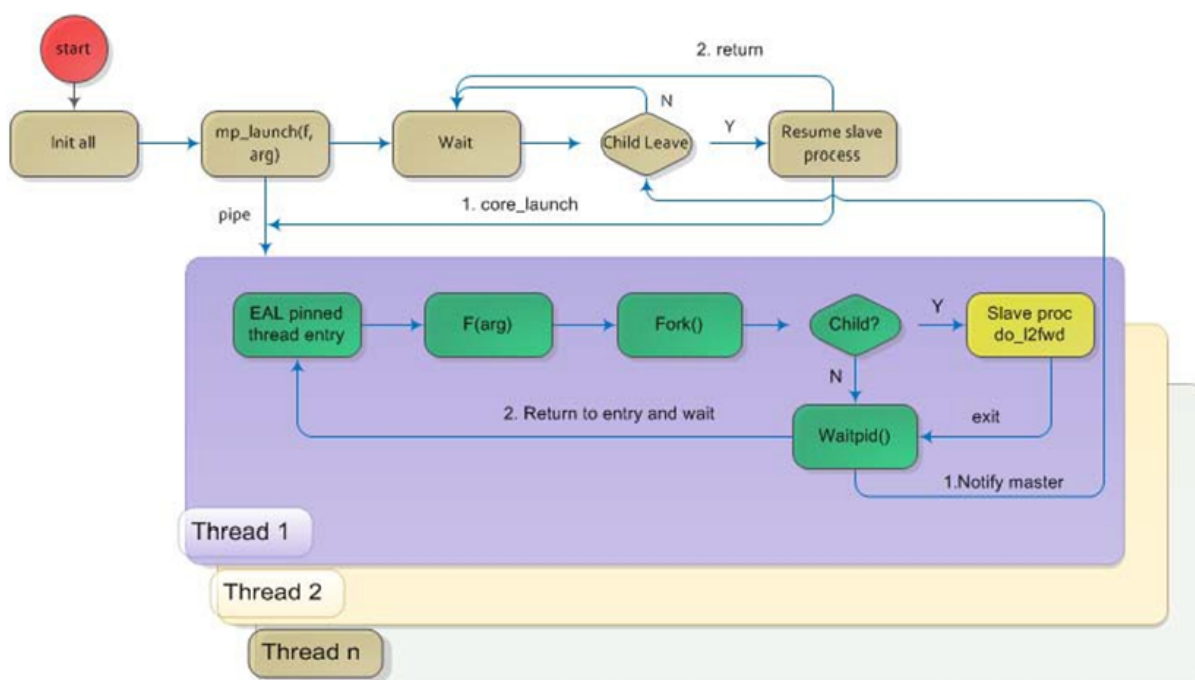

Figure 19.3: Master-slave Process Workflow

The master process calls the `rte_eal_mp_remote_launch()` EAL function to launch an application function for each pinned thread through the pipe. Then, it waits to check if any slave processes have exited. If so, the process tries to re-initialize the resources that belong to that slave and launch them in the pinned thread entry again. The following section describes the recovery procedures in more detail.

For each pinned thread in EAL, after reading any data from the pipe, it tries to call the function that the application specified. In this master specified function, a `fork()` call creates a slave process that performs the L2 forwarding task. Then, the function waits until the slave exits, is killed or crashes. Thereafter, it notifies the master of this event and returns. Finally, the EAL pinned thread waits until the new function is launched.

After discussing the master-slave model, it is necessary to mention another issue, global and static variables.

For multiple-thread cases, all global and static variables have only one copy and they can be accessed by any thread if applicable. So, they can be used to sync or share data among threads.

In the previous examples, each process has separate global and static variables in memory and are independent of each other. If it is necessary to share the knowledge, some communication mechanism should be deployed, such as, memzone, ring, shared memory, and so on. The global or static variables are not a valid approach to share data among processes. For variables in this example, on the one hand, the slave process inherits all the knowledge of these variables after being created by the master. On the other hand, other processes cannot know if one or more processes modifies them after slave creation since that is the nature of a multiple process address space. But this does not mean that these variables cannot be used to share or sync data; it depends on the use case. The following are the possible use cases:

1. The master process starts and initializes a variable and it will never be changed after slave processes created. This case is OK.
2. After the slave processes are created, the master or slave cores need to change a variable, but other processes do not need to know the change. This case is also OK.
3. After the slave processes are created, the master or a slave needs to change a variable. In the meantime, one or more other process needs to be aware of the change. In this case, global and static variables cannot be used to share knowledge. Another communication mechanism is needed. A simple approach without lock protection can be a heap buffer allocated by `rte_malloc` or mem zone.

### **Slave Process Recovery Mechanism**

Before talking about the recovery mechanism, it is necessary to know what is needed before a new slave instance can run if a previous one exited.

When a slave process exits, the system returns all the resources allocated for this process automatically. However, this does not include the resources that were allocated by the DPDK. All the hardware resources are shared among the processes, which include memzone, mempool, ring, a heap buffer allocated by the `rte_malloc` library, and so on. If the new instance runs and the allocated resource is not returned, either resource allocation failed or the hardware resource is lost forever.

When a slave process runs, it may have dependencies on other processes. They could have execution sequence orders; they could share the ring to communicate; they could share the

same port for reception and forwarding; they could use lock structures to do exclusive access in some critical path. What happens to the dependent process(es) if the peer leaves? The consequence are varied since the dependency cases are complex. It depends on what the processed had shared. However, it is necessary to notify the peer(s) if one slave exited. Then, the peer(s) will be aware of that and wait until the new instance begins to run.

Therefore, to provide the capability to resume the new slave instance if the previous one exited, it is necessary to provide several mechanisms:

1. Keep a resource list for each slave process. Before a slave process run, the master should prepare a resource list. After it exits, the master could either delete the allocated resources and create new ones, or re-initialize those for use by the new instance.
2. Set up a notification mechanism for slave process exit cases. After the specific slave leaves, the master should be notified and then help to create a new instance. This mechanism is provided in Section [Master-slave Process Models](#).
3. Use a synchronization mechanism among dependent processes. The master should have the capability to stop or kill slave processes that have a dependency on the one that has exited. Then, after the new instance of exited slave process begins to run, the dependency ones could resume or run from the start. The example sends a STOP command to slave processes dependent on the exited one, then they will exit. Thereafter, the master creates new instances for the exited slave processes.

The following diagram describes slave process recovery.

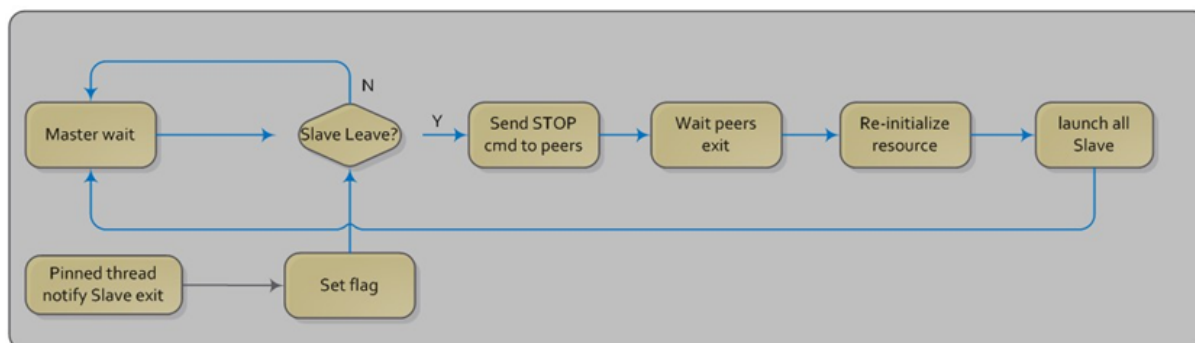

Figure 19.4: Slave Process Recovery Process Flow

## Floating Process Support

When the DPDK application runs, there is always a `-c` option passed in to indicate the cores that are enabled. Then, the DPDK creates a thread for each enabled core. By doing so, it creates a 1:1 mapping between the enabled core and each thread. The enabled core always has an ID, therefore, each thread has a unique core ID in the DPDK execution environment. With the ID, each thread can easily access the structures or resources exclusively belonging to it without using function parameter passing. It can easily use the `rte_lcore_id()` function to get the value in every function that is called.

For threads/processes not created in that way, either pinned to a core or not, they will not own a unique ID and the `rte_lcore_id()` function will not work in the correct way. However, sometimes these threads/processes still need the unique ID mechanism to do easy access on structures or resources. For example, the DPDK mempool library provides a local cache mechanism (refer

to the “Local Cache” section of the *DPDK Programmer’s Guide*) for fast element allocation and freeing. If using a non-unique ID or a fake one, a race condition occurs if two or more threads/processes with the same core ID try to use the local cache.

Therefore, unused core IDs from the passing of parameters with the `-c` option are used to organize the core ID allocation array. Once the floating process is spawned, it tries to allocate a unique core ID from the array and release it on exit.

A natural way to spawn a floating process is to use the `fork()` function and allocate a unique core ID from the unused core ID array. However, it is necessary to write new code to provide a notification mechanism for slave exit and make sure the process recovery mechanism can work with it.

To avoid producing redundant code, the Master-Slave process model is still used to spawn floating processes, then cancel the affinity to specific cores. Besides that, clear the core ID assigned to the DPDK spawning a thread that has a 1:1 mapping with the core mask. Thereafter, get a new core ID from the unused core ID allocation array.

## Run the Application

This example has a command line similar to the L2 Forwarding sample application with a few differences.

To run the application, start one copy of the `l2fwd_fork` binary in one terminal. Unlike the L2 Forwarding example, this example requires at least three cores since the master process will wait and be accountable for slave process recovery. The command is as follows:

```
#./build/l2fwd_fork -c 1c -n 4 -- -p 3 -f
```

This example provides another `-f` option to specify the use of floating process. If not specified, the example will use a pinned process to perform the L2 forwarding task.

To verify the recovery mechanism, proceed as follows: First, check the PID of the slave processes:

```
#ps -fe | grep l2fwd_fork
root 5136 4843 29 11:11 pts/1 00:00:05 ./build/l2fwd_fork
root 5145 5136 98 11:11 pts/1 00:00:11 ./build/l2fwd_fork
root 5146 5136 98 11:11 pts/1 00:00:11 ./build/l2fwd_fork
```

Then, kill one of the slaves:

```
#kill -9 5145
```

After 1 or 2 seconds, check whether the slave has resumed:

```
#ps -fe | grep l2fwd_fork
root 5136 4843 3 11:11 pts/1 00:00:06 ./build/l2fwd_fork
root 5247 5136 99 11:14 pts/1 00:00:01 ./build/l2fwd_fork
root 5248 5136 99 11:14 pts/1 00:00:01 ./build/l2fwd_fork
```

It can also monitor the traffic generator statics to see whether slave processes have resumed.

## Explanation

As described in previous sections, not all global and static variables need to change to be accessible in multiple processes; it depends on how they are used. In this example, the statics info on packets dropped/forwarded/received count needs to be updated by the slave process, and the master needs to see the update and print them out. So, it needs to allocate a heap buffer using `rte_zmalloc`. In addition, if the `-f` option is specified, an array is needed to store the allocated core ID for the floating process so that the master can return it after a slave has exited accidentally.

```
static int
l2fwd_malloc_shared_struct(void)
{
    port_statistics = rte_zmalloc("port_stat", sizeof(struct l2fwd_port_statistics) * RTE_MAX_
    if (port_statistics == NULL)
        return -1;

    /* allocate mapping_id array */

    if (float_proc) {
        int i;

        mapping_id = rte_malloc("mapping_id", sizeof(unsigned) * RTE_MAX_LCORE, 0);
        if (mapping_id == NULL)
            return -1;

        for (i = 0 ;i < RTE_MAX_LCORE; i++)
            mapping_id[i] = INVALID_MAPPING_ID;

    }
    return 0;
}
```

For each slave process, packets are received from one port and forwarded to another port that another slave is operating on. If the other slave exits accidentally, the port it is operating on may not work normally, so the first slave cannot forward packets to that port. There is a dependency on the port in this case. So, the master should recognize the dependency. The following is the code to detect this dependency:

```
for (portid = 0; portid < nb_ports; portid++) {
    /* skip ports that are not enabled */

    if ((l2fwd_enabled_port_mask & (1 << portid)) == 0)
        continue;

    /* Find pair ports' lcores */

    find_lcore = find_pair_lcore = 0;
    pair_port = l2fwd_dst_ports[portid];

    for (i = 0; i < RTE_MAX_LCORE; i++) {
        if (!rte_lcore_is_enabled(i))
            continue;

        for (j = 0; j < lcore_queue_conf[i].n_rx_port; j++) {
            if (lcore_queue_conf[i].rx_port_list[j] == portid) {
                lcore = i;
                find_lcore = 1;
                break;
            }
        }
    }
}
```

```

    }

    if (lcore_queue_conf[i].rx_port_list[j] == pair_port) {
        pair_lcore = i;
        find_pair_lcore = 1;
        break;
    }
}

if (find_lcore && find_pair_lcore)
    break;
}

if (!find_lcore || !find_pair_lcore)
    rte_exit(EXIT_FAILURE, "Not find port=%d pair\\n", portid);

printf("lcore %u and %u paired\\n", lcore, pair_lcore);

lcore_resource[lcore].pair_id = pair_lcore;
lcore_resource[pair_lcore].pair_id = lcore;
}

```

Before launching the slave process, it is necessary to set up the communication channel between the master and slave so that the master can notify the slave if its peer process with the dependency exited. In addition, the master needs to register a callback function in the case where a specific slave exited.

```

for (i = 0; i < RTE_MAX_LCORE; i++) {
    if (lcore_resource[i].enabled) {
        /* Create ring for master and slave communication */

        ret = create_ms_ring(i);
        if (ret != 0)
            rte_exit(EXIT_FAILURE, "Create ring for lcore=%u failed", i);

        if (flib_register_slave_exit_notify(i, slave_exit_cb) != 0)
            rte_exit(EXIT_FAILURE, "Register master_trace_slave_exit failed");
    }
}

```

After launching the slave process, the master waits and prints out the port statistics periodically. If an event indicating that a slave process exited is detected, it sends the STOP command to the peer and waits until it has also exited. Then, it tries to clean up the execution environment and prepare new resources. Finally, the new slave instance is launched.

```

while (1) {
    sleep(1);
    cur_tsc = rte_rdtsc();
    diff_tsc = cur_tsc - prev_tsc;

    /* if timer is enabled */

    if (timer_period > 0) {
        /* advance the timer */
        timer_tsc += diff_tsc;

        /* if timer has reached its timeout */
        if (unlikely(timer_tsc >= (uint64_t) timer_period)) {
            print_stats();

            /* reset the timer */

```



```

        timer_tsc = 0;
    }
}

prev_tsc = cur_tsc;

/* Check any slave need restart or recreate */

rte_spinlock_lock(&res_lock);

for (i = 0; i < RTE_MAX_LCORE; i++) {
    struct lcore_resource_struct *res = &lcore_resource[i];
    struct lcore_resource_struct *pair = &lcore_resource[res->pair_id];

    /* If find slave exited, try to reset pair */

    if (res->enabled && res->flags && pair->enabled) {
        if (!pair->flags) {
            master_sendcmd_with_ack(pair->lcore_id, CMD_STOP);
            rte_spinlock_unlock(&res_lock);
            sleep(1);
            rte_spinlock_lock(&res_lock);
            if (pair->flags)
                continue;
        }

        if (reset_pair(res->lcore_id, pair->lcore_id) != 0)
            rte_exit(EXIT_FAILURE, "failed to reset slave");

        res->flags = 0;
        pair->flags = 0;
    }
}
rte_spinlock_unlock(&res_lock);
}

```

When the slave process is spawned and starts to run, it checks whether the floating process option is applied. If so, it clears the affinity to a specific core and also sets the unique core ID to 0. Then, it tries to allocate a new core ID. Since the core ID has changed, the resource allocated by the master cannot work, so it remaps the resource to the new core ID slot.

```

static int
l2fwd_launch_one_lcore( attribute ((unused)) void *dummy)
{
    unsigned lcore_id = rte_lcore_id();

    if (float_proc) {
        unsigned flcore_id;

        /* Change it to floating process, also change it's lcore_id */

        clear_cpu_affinity();

        RTE_PER_LCORE(_lcore_id) = 0;

        /* Get a lcore_id */

        if (flib_assign_lcore_id() < 0 ) {
            printf("flib_assign_lcore_id failed\n");
            return -1;
        }
    }
}

```

```
    flcore_id = rte_lcore_id();

    /* Set mapping id, so master can return it after slave exited */

    mapping_id[lcore_id] = flcore_id;
    printf("Org lcore_id = %u, cur lcore_id = %u\n",lcore_id, flcore_id);
    remapping_slave_resource(lcore_id, flcore_id);
}

l2fwd_main_loop();

/* return lcore_id before return */
if (float_proc) {
    flib_free_lcore_id(rte_lcore_id());
    mapping_id[lcore_id] = INVALID_MAPPING_ID;
}
return 0;
}
```

## QOS METERING SAMPLE APPLICATION

The QoS meter sample application is an example that demonstrates the use of DPDK to provide QoS marking and metering, as defined by RFC2697 for Single Rate Three Color Marker (srTCM) and RFC 2698 for Two Rate Three Color Marker (trTCM) algorithm.

### 20.1 Overview

The application uses a single thread for reading the packets from the RX port, metering, marking them with the appropriate color (green, yellow or red) and writing them to the TX port.

A policing scheme can be applied before writing the packets to the TX port by dropping or changing the color of the packet in a static manner depending on both the input and output colors of the packets that are processed by the meter.

The operation mode can be selected as compile time out of the following options:

- Simple forwarding
- srTCM color blind
- srTCM color aware
- srTCM color blind
- srTCM color aware

Please refer to RFC2697 and RFC2698 for details about the srTCM and trTCM configurable parameters (CIR, CBS and EBS for srTCM; CIR, PIR, CBS and PBS for trTCM).

The color blind modes are functionally equivalent with the color-aware modes when all the incoming packets are colored as green.

### 20.2 Compiling the Application

1. Go to the example directory:

```
export RTE_SDK=/path/to/rte_sdk
cd ${RTE_SDK}/examples/qos_meter
```

2. Set the target (a default target is used if not specified):

---

**Note:** This application is intended as a linuxapp only.

---

```
export RTE_TARGET=x86_64-native-linuxapp-gcc
```

3. Build the application:

```
make
```

## 20.3 Running the Application

The application execution command line is as below:

```
./qos_meter [EAL options] -- -p PORTMASK
```

The application is constrained to use a single core in the EAL core mask and 2 ports only in the application port mask (first port from the port mask is used for RX and the other port in the core mask is used for TX).

Refer to *DPDK Getting Started Guide* for general information on running applications and the Environment Abstraction Layer (EAL) options.

## 20.4 Explanation

Selecting one of the metering modes is done with these defines:

```
#define APP_MODE_FWD 0
#define APP_MODE_SRTCM_COLOR_BLIND 1
#define APP_MODE_SRTCM_COLOR_AWARE 2
#define APP_MODE_TRTCM_COLOR_BLIND 3
#define APP_MODE_TRTCM_COLOR_AWARE 4

#define APP_MODE APP_MODE_SRTCM_COLOR_BLIND
```

To simplify debugging (for example, by using the traffic generator RX side MAC address based packet filtering feature), the color is defined as the LSB byte of the destination MAC address.

The traffic meter parameters are configured in the application source code with following default values:

```
struct rte_meter_srtcm_params app_srtcm_params[] = {
    {.cir = 1000000 * 46, .cbs = 2048, .ebs = 2048},
};

struct rte_meter_trtcm_params app_trtcm_params[] = {
    {.cir = 1000000 * 46, .pir = 1500000 * 46, .cbs = 2048, .pbs = 2048},
};
```

Assuming the input traffic is generated at line rate and all packets are 64 bytes Ethernet frames (IPv4 packet size of 46 bytes) and green, the expected output traffic should be marked as shown in the following table:

Table 20.1: Output Traffic Marking

Mode	Green (Mpps)	Yellow (Mpps)	Red (Mpps)
srTCM blind	1	1	12.88
srTCM color	1	1	12.88
trTCM blind	1	0.5	13.38
trTCM color	1	0.5	13.38
FWD	14.88	0	0

To set up the policing scheme as desired, it is necessary to modify the main.h source file, where this policy is implemented as a static structure, as follows:

```
int policer_table[e_RTE_METER_COLORS][e_RTE_METER_COLORS] =
{
  { GREEN, RED, RED},
  { DROP, YELLOW, RED},
  { DROP, DROP, RED}
};
```

Where rows indicate the input color, columns indicate the output color, and the value that is stored in the table indicates the action to be taken for that particular case.

There are four different actions:

- GREEN: The packet's color is changed to green.
- YELLOW: The packet's color is changed to yellow.
- RED: The packet's color is changed to red.
- DROP: The packet is dropped.

In this particular case:

- Every packet which input and output color are the same, keeps the same color.
- Every packet which color has improved is dropped (this particular case can't happen, so these values will not be used).
- For the rest of the cases, the color is changed to red.

## QOS SCHEDULER SAMPLE APPLICATION

The QoS sample application demonstrates the use of the DPDK to provide QoS scheduling.

### 21.1 Overview

The architecture of the QoS scheduler application is shown in the following figure.

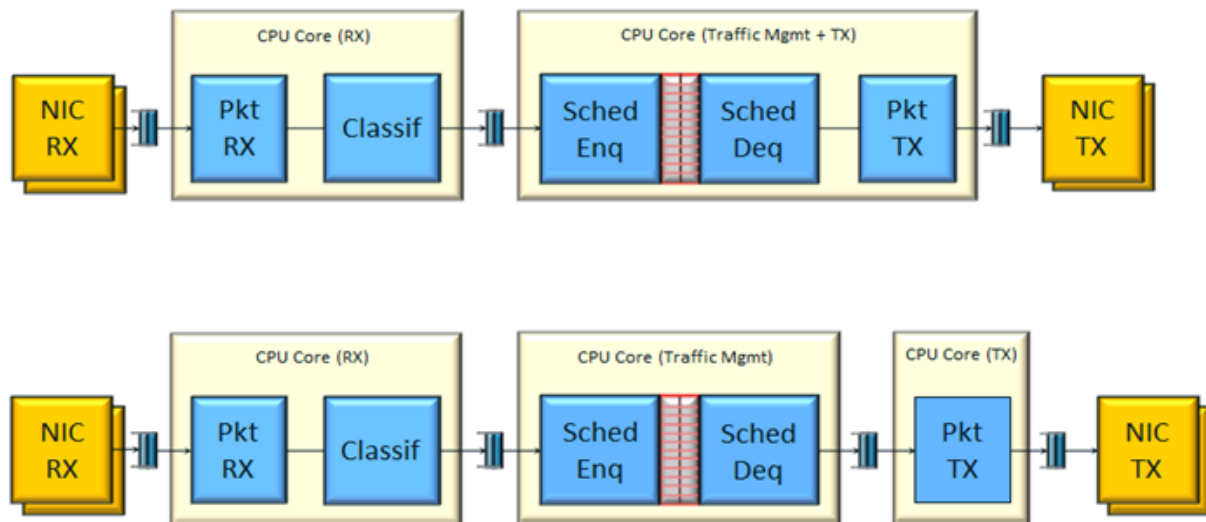

Figure 21.1: QoS Scheduler Application Architecture

There are two flavors of the runtime execution for this application, with two or three threads per each packet flow configuration being used. The RX thread reads packets from the RX port, classifies the packets based on the double VLAN (outer and inner) and the lower two bytes of the IP destination address and puts them into the ring queue. The worker thread dequeues the packets from the ring and calls the QoS scheduler enqueue/dequeue functions. If a separate TX core is used, these are sent to the TX ring. Otherwise, they are sent directly to the TX port. The TX thread, if present, reads from the TX ring and write the packets to the TX port.

### 21.2 Compiling the Application

To compile the application:

1. Go to the sample application directory:

```
export RTE_SDK=/path/to/rte_sdk cd ${RTE_SDK}/examples/qos_sched
```

2. Set the target (a default target is used if not specified). For example:

**Note:** This application is intended as a linuxapp only.

```
export RTE_TARGET=x86_64-native-linuxapp-gcc
```

3. Build the application:

```
make
```

**Note:** To get statistics on the sample app using the command line interface as described in the next section, DPDK must be compiled defining `CONFIG_RTE_SCHED_COLLECT_STATS`, which can be done by changing the configuration file for the specific target to be compiled.

## 21.3 Running the Application

**Note:** In order to run the application, a total of at least 4 G of huge pages must be set up for each of the used sockets (depending on the cores in use).

The application has a number of command line options:

```
./qos_sched [EAL options] -- <APP PARAMS>
```

Mandatory application parameters include:

- `-pfc` "RX PORT, TX PORT, RX LCORE, WT LCORE, TX CORE": Packet flow configuration. Multiple pfc entities can be configured in the command line, having 4 or 5 items (if TX core defined or not).

Optional application parameters include:

- `-i`: It makes the application to start in the interactive mode. In this mode, the application shows a command line that can be used for obtaining statistics while scheduling is taking place (see interactive mode below for more information).
- `-mst n`: Master core index (the default value is 1).
- `-rsz "A, B, C"`: Ring sizes:
  - A = Size (in number of buffer descriptors) of each of the NIC RX rings read by the I/O RX lcores (the default value is 128).
  - B = Size (in number of elements) of each of the software rings used by the I/O RX lcores to send packets to worker lcores (the default value is 8192).
  - C = Size (in number of buffer descriptors) of each of the NIC TX rings written by worker lcores (the default value is 256)
- `-bsz "A, B, C, D"`: Burst sizes
  - A = I/O RX lcore read burst size from the NIC RX (the default value is 64)

- B = I/O RX lcore write burst size to the output software rings, worker lcore read burst size from input software rings, QoS enqueue size (the default value is 64)
- C = QoS dequeue size (the default value is 32)
- D = Worker lcore write burst size to the NIC TX (the default value is 64)
- -msz M: Mempool size (in number of mbufs) for each pfc (default 2097152)
- -rth "A, B, C": The RX queue threshold parameters
- A = RX prefetch threshold (the default value is 8)
- B = RX host threshold (the default value is 8)
- C = RX write-back threshold (the default value is 4)
- -tth "A, B, C": TX queue threshold parameters
- A = TX prefetch threshold (the default value is 36)
- B = TX host threshold (the default value is 0)
- C = TX write-back threshold (the default value is 0)
- -cfg FILE: Profile configuration to load

Refer to *DPDK Getting Started Guide* for general information on running applications and the Environment Abstraction Layer (EAL) options.

The profile configuration file defines all the port/subport/pipe/traffic class/queue parameters needed for the QoS scheduler configuration.

The profile file has the following format:

```

; port configuration [port]

frame overhead = 24
number of subports per port = 1
number of pipes per subport = 4096
queue sizes = 64 64 64 64

; Subport configuration

[subport 0]
tb rate = 1250000000; Bytes per second
tb size = 1000000; Bytes
tc 0 rate = 1250000000; Bytes per second
tc 1 rate = 1250000000; Bytes per second
tc 2 rate = 1250000000; Bytes per second
tc 3 rate = 1250000000; Bytes per second
tc period = 10; Milliseconds
tc oversubscription period = 10; Milliseconds

pipe 0-4095 = 0; These pipes are configured with pipe profile 0

; Pipe configuration

[pipe profile 0]
tb rate = 305175; Bytes per second
tb size = 1000000; Bytes

tc 0 rate = 305175; Bytes per second
tc 1 rate = 305175; Bytes per second
tc 2 rate = 305175; Bytes per second

```



```

tc 3 rate = 305175; Bytes per second
tc period = 40; Milliseconds

tc 0 oversubscription weight = 1
tc 1 oversubscription weight = 1
tc 2 oversubscription weight = 1
tc 3 oversubscription weight = 1

tc 0 wrr weights = 1 1 1 1
tc 1 wrr weights = 1 1 1 1
tc 2 wrr weights = 1 1 1 1
tc 3 wrr weights = 1 1 1 1

; RED params per traffic class and color (Green / Yellow / Red)

[red]
tc 0 wred min = 48 40 32
tc 0 wred max = 64 64 64
tc 0 wred inv prob = 10 10 10
tc 0 wred weight = 9 9 9

tc 1 wred min = 48 40 32
tc 1 wred max = 64 64 64
tc 1 wred inv prob = 10 10 10
tc 1 wred weight = 9 9 9

tc 2 wred min = 48 40 32
tc 2 wred max = 64 64 64
tc 2 wred inv prob = 10 10 10
tc 2 wred weight = 9 9 9

tc 3 wred min = 48 40 32
tc 3 wred max = 64 64 64
tc 3 wred inv prob = 10 10 10
tc 3 wred weight = 9 9 9

```

### 21.3.1 Interactive mode

These are the commands that are currently working under the command line interface:

- Control Commands
- -quit: Quits the application.
- General Statistics
  - stats app: Shows a table with in-app calculated statistics.
  - stats port X subport Y: For a specific subport, it shows the number of packets that went through the scheduler properly and the number of packets that were dropped. The same information is shown in bytes. The information is displayed in a table separating it in different traffic classes.
  - stats port X subport Y pipe Z: For a specific pipe, it shows the number of packets that went through the scheduler properly and the number of packets that were dropped. The same information is shown in bytes. This information is displayed in a table separating it in individual queues.
- Average queue size

All of these commands work the same way, averaging the number of packets throughout a specific subset of queues.

Two parameters can be configured for this prior to calling any of these commands:

- `qavg n X`: `n` is the number of times that the calculation will take place. Bigger numbers provide higher accuracy. The default value is 10.
- `qavg period X`: `period` is the number of microseconds that will be allowed between each calculation. The default value is 100.

The commands that can be used for measuring average queue size are:

- `qavg port X subport Y`: Show average queue size per subport.
- `qavg port X subport Y tc Z`: Show average queue size per subport for a specific traffic class.
- `qavg port X subport Y pipe Z`: Show average queue size per pipe.
- `qavg port X subport Y pipe Z tc A`: Show average queue size per pipe for a specific traffic class.
- `qavg port X subport Y pipe Z tc A q B`: Show average queue size of a specific queue.

### 21.3.2 Example

The following is an example command with a single packet flow configuration:

```
./qos_sched -c a2 -n 4 -- --pfc "3,2,5,7" --cfg ./profile.cfg
```

This example uses a single packet flow configuration which creates one RX thread on lcore 5 reading from port 3 and a worker thread on lcore 7 writing to port 2.

Another example with 2 packet flow configurations using different ports but sharing the same core for QoS scheduler is given below:

```
./qos_sched -c c6 -n 4 -- --pfc "3,2,2,6,7" --pfc "1,0,2,6,7" --cfg ./profile.cfg
```

Note that independent cores for the packet flow configurations for each of the RX, WT and TX thread are also supported, providing flexibility to balance the work.

The EAL coremask is constrained to contain the default mastercore 1 and the RX, WT and TX cores only.

## 21.4 Explanation

The Port/Subport/Pipe/Traffic Class/Queue are the hierarchical entities in a typical QoS application:

- A subport represents a predefined group of users.
- A pipe represents an individual user/subscriber.
- A traffic class is the representation of a different traffic type with a specific loss rate, delay and jitter requirements; such as data voice, video or data transfers.

- A queue hosts packets from one or multiple connections of the same type belonging to the same user.

The traffic flows that need to be configured are application dependent. This application classifies based on the QinQ double VLAN tags and the IP destination address as indicated in the following table.

Table 21.1: Entity Types

Level Name	Siblings per Parent	QoS Functional Description	Selected By
Port	.	Ethernet port	Physical port
Subport	Config (8)	Traffic shaped (token bucket)	Outer VLAN tag
Pipe	Config (4k)	Traffic shaped (token bucket)	Inner VLAN tag
Traffic Class	4	TCs of the same pipe services in strict priority	Destination IP address (0.0.X.0)
Queue	4	Queue of the same TC serviced in WRR	Destination IP address (0.0.0.X)

Please refer to the “QoS Scheduler” chapter in the *DPDK Programmer’s Guide* for more information about these parameters.

## INTEL® QUICKASSIST TECHNOLOGY SAMPLE APPLICATION

This sample application demonstrates the use of the cryptographic operations provided by the Intel® QuickAssist Technology from within the DPDK environment. Therefore, building and running this application requires having both the DPDK and the QuickAssist Technology Software Library installed, as well as at least one Intel® QuickAssist Technology hardware device present in the system.

For this sample application, there is a dependency on either of:

- Intel® Communications Chipset 8900 to 8920 Series Software for Linux\* package
- Intel® Communications Chipset 8925 to 8955 Series Software for Linux\* package

### 22.1 Overview

An overview of the application is provided in Fig. 22.1. For simplicity, only two NIC ports and one Intel® QuickAssist Technology device are shown in this diagram, although the number of NIC ports and Intel® QuickAssist Technology devices can be different.

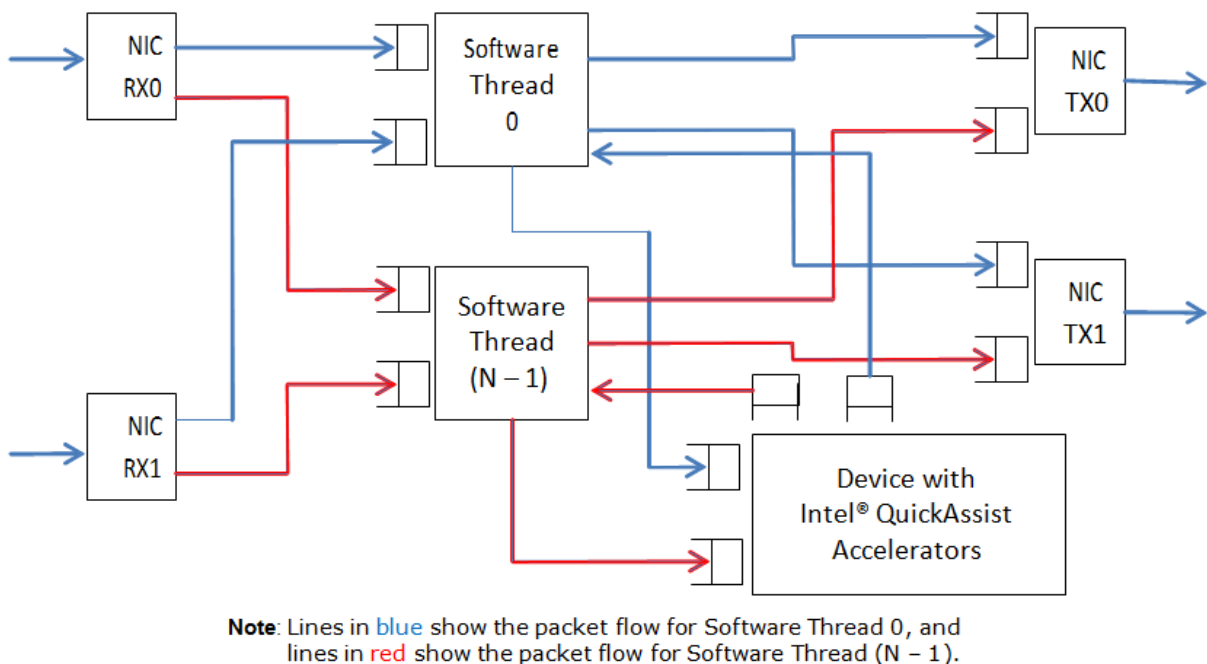

Figure 22.1: Intel® QuickAssist Technology Application Block Diagram

The application allows the configuration of the following items:

- Number of NIC ports
- Number of logical cores (lcores)
- Mapping of NIC RX queues to logical cores

Each lcore communicates with every cryptographic acceleration engine in the system through a pair of dedicated input - output queues. Each lcore has a dedicated NIC TX queue with every NIC port in the system. Therefore, each lcore reads packets from its NIC RX queues and cryptographic accelerator output queues and writes packets to its NIC TX queues and cryptographic accelerator input queues.

Each incoming packet that is read from a NIC RX queue is either directly forwarded to its destination NIC TX port (forwarding path) or first sent to one of the Intel® QuickAssist Technology devices for either encryption or decryption before being sent out on its destination NIC TX port (cryptographic path).

The application supports IPv4 input packets only. For each input packet, the decision between the forwarding path and the cryptographic path is taken at the classification stage based on the value of the IP source address field read from the input packet. Assuming that the IP source address is A.B.C.D, then if:

- D = 0: the forwarding path is selected (the packet is forwarded out directly)
- D = 1: the cryptographic path for encryption is selected (the packet is first encrypted and then forwarded out)
- D = 2: the cryptographic path for decryption is selected (the packet is first decrypted and then forwarded out)

For the cryptographic path cases (D = 1 or D = 2), byte C specifies the cipher algorithm and byte B the cryptographic hash algorithm to be used for the current packet. Byte A is not used and can be any value. The cipher and cryptographic hash algorithms supported by this application are listed in the `crypto.h` header file.

For each input packet, the destination NIC TX port is decided at the forwarding stage (executed after the cryptographic stage, if enabled for the packet) by looking at the RX port index of the `dst_ports[ ]` array, which was initialized at startup, being the outport the adjacent enabled port. For example, if ports 1,3,5 and 6 are enabled, for input port 1, output port will be 3 and vice versa, and for input port 5, output port will be 6 and vice versa.

For the cryptographic path, it is the payload of the IPv4 packet that is encrypted or decrypted.

### 22.1.1 Setup

Building and running this application requires having both the DPDK package and the QuickAssist Technology Software Library installed, as well as at least one Intel® QuickAssist Technology hardware device present in the system.

For more details on how to build and run DPDK and Intel® QuickAssist Technology applications, please refer to the following documents:

- *DPDK Getting Started Guide*
- Intel® Communications Chipset 8900 to 8920 Series Software for Linux\* Getting Started Guide (440005)

- Intel® Communications Chipset 8925 to 8955 Series Software for Linux\* Getting Started Guide (523128)

For more details on the actual platforms used to validate this application, as well as performance numbers, please refer to the Test Report, which is accessible by contacting your Intel representative.

## 22.2 Building the Application

Steps to build the application:

1. Set up the following environment variables:

```
export RTE_SDK=<Absolute path to the DPDK installation folder>
export ICP_ROOT=<Absolute path to the Intel QAT installation folder>
```

2. Set the target (a default target is used if not specified). For example:

```
export RTE_TARGET=x86_64-native-linuxapp-gcc
```

Refer to the *DPDK Getting Started Guide* for possible RTE\_TARGET values.

3. Build the application:

```
cd ${RTE_SDK}/examples/dpdk_qat
make
```

## 22.3 Running the Application

### 22.3.1 Intel® QuickAssist Technology Configuration Files

The Intel® QuickAssist Technology configuration files used by the application are located in the config\_files folder in the application folder. There following sets of configuration files are included in the DPDK package:

- Stargo CRB (single CPU socket): located in the stargo folder
  - dh89xcc\_qa\_dev0.conf
- Shumway CRB (dual CPU socket): located in the shumway folder
  - dh89xcc\_qa\_dev0.conf
  - dh89xcc\_qa\_dev1.conf
- Coletto Creek: located in the coletto folder
  - dh895xcc\_qa\_dev0.conf

The relevant configuration file(s) must be copied to the /etc/ directory.

Please note that any change to these configuration files requires restarting the Intel® QuickAssist Technology driver using the following command:

```
# service qat_service restart
```

Refer to the following documents for information on the Intel® QuickAssist Technology configuration files:

- Intel® Communications Chipset 8900 to 8920 Series Software Programmer's Guide
- Intel® Communications Chipset 8925 to 8955 Series Software Programmer's Guide
- Intel® Communications Chipset 8900 to 8920 Series Software for Linux\* Getting Started Guide.
- Intel® Communications Chipset 8925 to 8955 Series Software for Linux\* Getting Started Guide.

### 22.3.2 Traffic Generator Setup and Application Startup

The application has a number of command line options:

```
dpdk_qat [EAL options] - -p PORTMASK [--no-promisc] [--config '(port,queue,lcore)[,(port,queue,lcore)]']
```

where,

- -p PORTMASK: Hexadecimal bitmask of ports to configure
- --no-promisc: Disables promiscuous mode for all ports, so that only packets with the Ethernet MAC destination address set to the Ethernet address of the port are accepted. By default promiscuous mode is enabled so that packets are accepted regardless of the packet's Ethernet MAC destination address.
- --config'(port,queue,lcore)[,(port,queue,lcore)]': determines which queues from which ports are mapped to which cores.

Refer to Chapter 10 , “L3 Forwarding Sample Application” for more detailed descriptions of the --config command line option.

As an example, to run the application with two ports and two cores, which are using different Intel® QuickAssist Technology execution engines, performing AES-CBC-128 encryption with AES-XCBC-MAC-96 hash, the following settings can be used:

- Traffic generator source IP address: 0.9.6.1
- Command line:

```
./build/dpdk_qat -c 0xff -n 2 -- -p 0x3 --config '(0,0,1),(1,0,2)'
```

Refer to the *DPDK Test Report* for more examples of traffic generator setup and the application startup command lines. If no errors are generated in response to the startup commands, the application is running correctly.

## QUOTA AND WATERMARK SAMPLE APPLICATION

The Quota and Watermark sample application is a simple example of packet processing using Data Plane Development Kit (DPDK) that showcases the use of a quota as the maximum number of packets enqueue/dequeue at a time and low and high watermarks to signal low and high ring usage respectively.

Additionally, it shows how ring watermarks can be used to feedback congestion notifications to data producers by temporarily stopping processing overloaded rings and sending Ethernet flow control frames.

This sample application is split in two parts:

- `qw` - The core quota and watermark sample application
- `qwctl` - A command line tool to alter quota and watermarks while `qw` is running

### 23.1 Overview

The Quota and Watermark sample application performs forwarding for each packet that is received on a given port. The destination port is the adjacent port from the enabled port mask, that is, if the first four ports are enabled (port mask 0xf), ports 0 and 1 forward into each other, and ports 2 and 3 forward into each other. The MAC addresses of the forwarded Ethernet frames are not affected.

Internally, packets are pulled from the ports by the master logical core and put on a variable length processing pipeline, each stage of which being connected by rings, as shown in Fig. 23.1.

An adjustable quota value controls how many packets are being moved through the pipeline per enqueue and dequeue. Adjustable watermark values associated with the rings control a back-off mechanism that tries to prevent the pipeline from being overloaded by:

- Stopping enqueueing on rings for which the usage has crossed the high watermark threshold
- Sending Ethernet pause frames
- Only resuming enqueueing on a ring once its usage goes below a global low watermark threshold

This mechanism allows congestion notifications to go up the ring pipeline and eventually lead to an Ethernet flow control frame being send to the source.



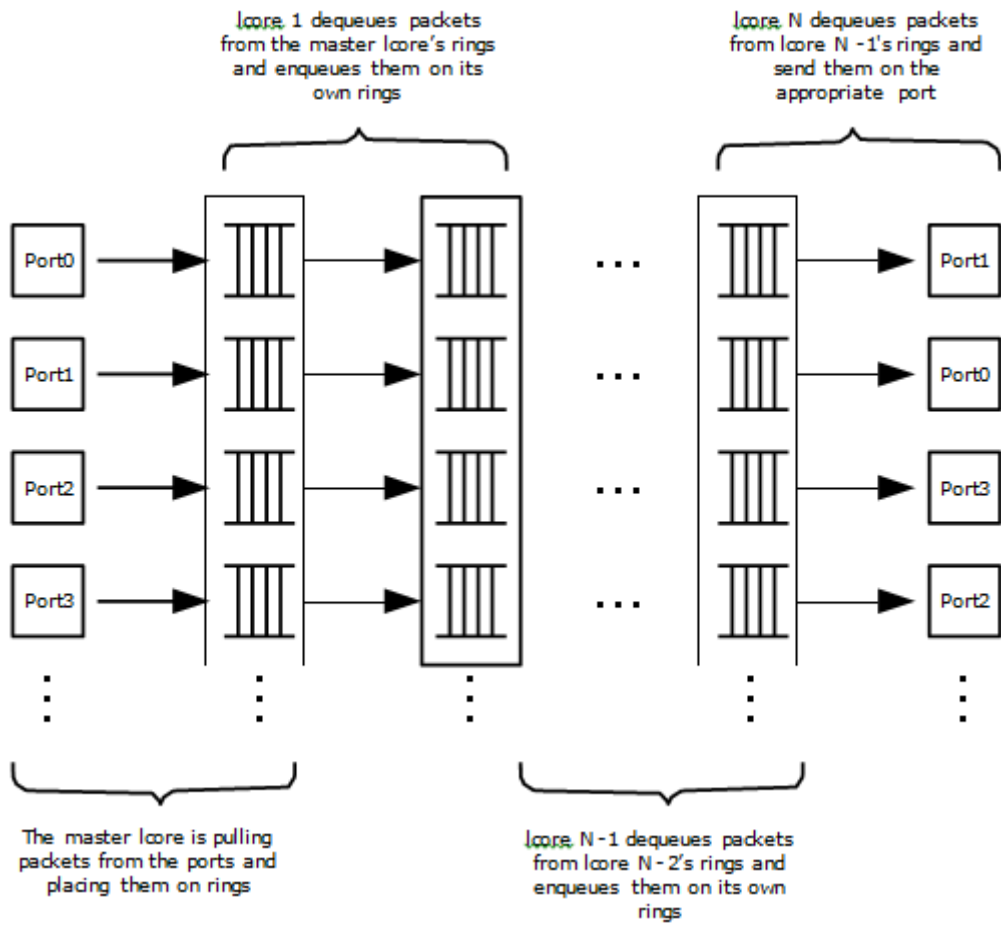

Figure 23.1: Pipeline Overview

On top of serving as an example of quota and watermark usage, this application can be used to benchmark ring based processing pipelines performance using a traffic- generator, as shown in Fig. 23.2.

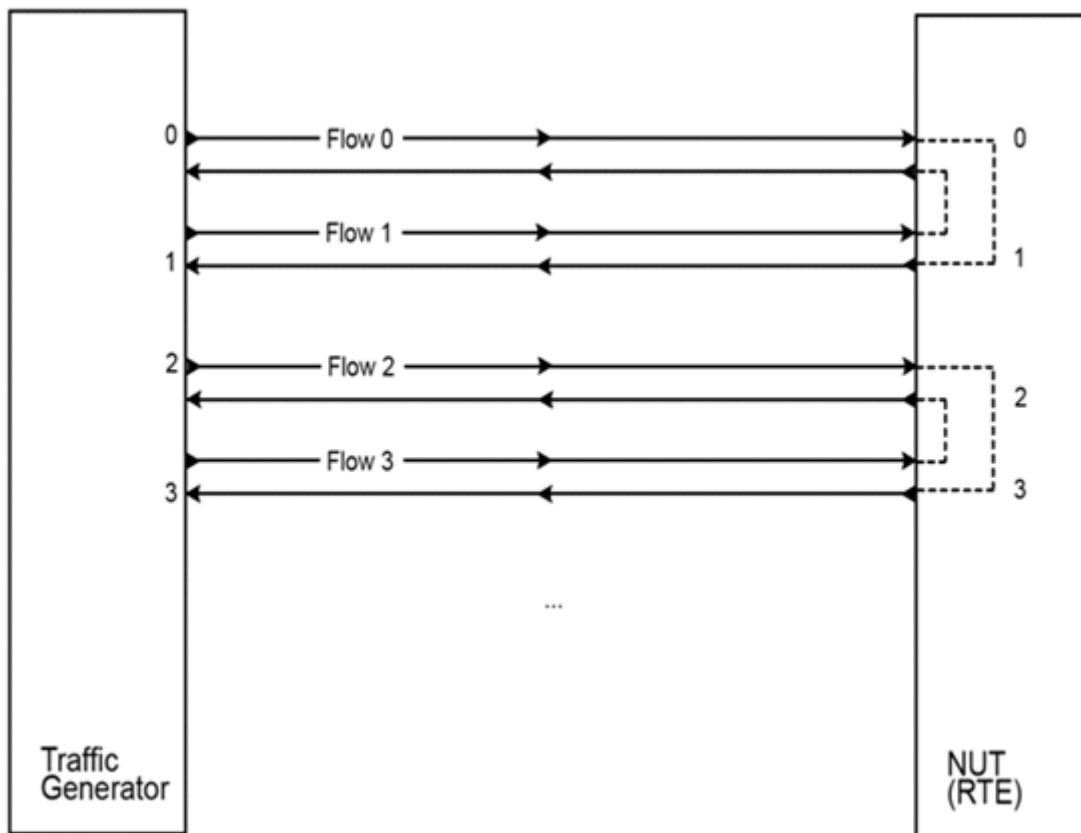

Figure 23.2: Ring-based Processing Pipeline Performance Setup

## 23.2 Compiling the Application

1. Go to the example directory:

```
export RTE_SDK=/path/to/rte_sdk
cd ${RTE_SDK}/examples/quota_watermark
```

2. Set the target (a default target is used if not specified). For example:

```
export RTE_TARGET=x86_64-native-linuxapp-gcc
```

See the *DPDK Getting Started Guide* for possible `RTE_TARGET` values.

3. Build the application:

```
make
```

## 23.3 Running the Application

The core application, `qw`, has to be started first.

Once it is up and running, one can alter quota and watermarks while it runs using the control application, `qwctl`.

### 23.3.1 Running the Core Application

The application requires a single command line option:

```
./qw/build/qw [EAL options] -- -p PORTMASK
```

where,

`-p PORTMASK`: A hexadecimal bitmask of the ports to configure

To run the application in a `linuxapp` environment with four logical cores and ports 0 and 2, issue the following command:

```
./qw/build/qw -c f -n 4 -- -p 5
```

Refer to the *DPDK Getting Started Guide* for general information on running applications and the Environment Abstraction Layer (EAL) options.

### 23.3.2 Running the Control Application

The control application requires a number of command line options:

```
./qwctl/build/qwctl [EAL options] --proc-type=secondary
```

The `--proc-type=secondary` option is necessary for the EAL to properly initialize the control application to use the same huge pages as the core application and thus be able to access its rings.

To run the application in a `linuxapp` environment on logical core 0, issue the following command:

```
./qwctl/build/qwctl -c 1 -n 4 --proc-type=secondary
```

Refer to the *DPDK Getting Started Guide* for general information on running applications and the Environment Abstraction Layer (EAL) options.

`qwctl` is an interactive command line that let the user change variables in a running instance of `qw`. The help command gives a list of available commands:

```
$ qwctl > help
```

## 23.4 Code Overview

The following sections provide a quick guide to the application's source code.

### 23.4.1 Core Application - `qw`

#### EAL and Drivers Setup

The EAL arguments are parsed at the beginning of the `main()` function:

```
ret = rte_eal_init(argc, argv);
if (ret < 0)
    rte_exit(EXIT_FAILURE, "Cannot initialize EAL\n");

argc -= ret;
argv += ret;
```

Then, a call to `init_dpdk()`, defined in `init.c`, is made to initialize the poll mode drivers:

```
void
init_dpdk(void)
{
    int ret;

    /* Bind the drivers to usable devices */

    ret = rte_eal_pci_probe();
    if (ret < 0)
        rte_exit(EXIT_FAILURE, "rte_eal_pci_probe(): error %d\n", ret);

    if (rte_eth_dev_count() < 2)
        rte_exit(EXIT_FAILURE, "Not enough Ethernet port available\n");
}
```

To fully understand this code, it is recommended to study the chapters that relate to the *Poll Mode Driver* in the *DPDK Getting Started Guide* and the *DPDK API Reference*.

## Shared Variables Setup

The quota and `low_watermark` shared variables are put into an `rte_memzone` using a call to `setup_shared_variables()`:

```
void
setup_shared_variables(void)
{
    const struct rte_memzone *qw_memzone;

    qw_memzone = rte_memzone_reserve(QUOTA_WATERMARK_MEMZONE_NAME, 2 * sizeof(int), rte_socket_id(0), RTE_MEMZONE_NORMAL);

    if (qw_memzone == NULL)
        rte_exit(EXIT_FAILURE, "%s\n", rte_strerror(rte_errno));

    quota = qw_memzone->addr;
    low_watermark = (unsigned int *) qw_memzone->addr + sizeof(int);
}
```

These two variables are initialized to a default value in `main()` and can be changed while `qw` is running using the `qwctl` control program.

## Application Arguments

The `qw` application only takes one argument: a port mask that specifies which ports should be used by the application. At least two ports are needed to run the application and there should be an even number of ports given in the port mask.

The port mask parsing is done in `parse_qw_args()`, defined in `args.c`.

## Mbuf Pool Initialization

Once the application's arguments are parsed, an mbuf pool is created. It contains a set of mbuf objects that are used by the driver and the application to store network packets:

```

/* Create a pool of mbuf to store packets */

mbuf_pool = rte_mempool_create("mbuf_pool", MBUF_PER_POOL, MBUF_SIZE, 32, sizeof(struct rte_pktmbuf_pool_private),
    rte_pktmbuf_pool_init, NULL, rte_pktmbuf_init, NULL, rte_socket_id(), 0);

if (mbuf_pool == NULL)
    rte_panic("%s\n", rte_strerror(rte_errno));

```

The `rte_mempool` is a generic structure used to handle pools of objects. In this case, it is necessary to create a pool that will be used by the driver, which expects to have some reserved space in the mempool structure, `sizeof(struct rte_pktmbuf_pool_private)` bytes.

The number of allocated pkt mbufs is `MBUF_PER_POOL`, with a size of `MBUF_SIZE` each. A per-lcore cache of 32 mbufs is kept. The memory is allocated in on the master lcore's socket, but it is possible to extend this code to allocate one mbuf pool per socket.

Two callback pointers are also given to the `rte_mempool_create()` function:

- The first callback pointer is to `rte_pktmbuf_pool_init()` and is used to initialize the private data of the mempool, which is needed by the driver. This function is provided by the mbuf API, but can be copied and extended by the developer.
- The second callback pointer given to `rte_mempool_create()` is the mbuf initializer.

The default is used, that is, `rte_pktmbuf_init()`, which is provided in the `rte_mbuf` library. If a more complex application wants to extend the `rte_pktmbuf` structure for its own needs, a new function derived from `rte_pktmbuf_init()` can be created.

## Ports Configuration and Pairing

Each port in the port mask is configured and a corresponding ring is created in the master lcore's array of rings. This ring is the first in the pipeline and will hold the packets directly coming from the port.

```

for (port_id = 0; port_id < RTE_MAX_ETHPORTS; port_id++)
    if (is_bit_set(port_id, portmask)) {
        configure_eth_port(port_id);
        init_ring(master_lcore_id, port_id);
    }

pair_ports();

```

The `configure_eth_port()` and `init_ring()` functions are used to configure a port and a ring respectively and are defined in `init.c`. They make use of the DPDK APIs defined in `rte_eth.h` and `rte_ring.h`.

`pair_ports()` builds the `port_pairs[]` array so that its key-value pairs are a mapping between reception and transmission ports. It is defined in `init.c`.

## Logical Cores Assignment

The application uses the master logical core to poll all the ports for new packets and enqueue them on a ring associated with the port.

Each logical core except the last runs `pipeline_stage()` after a ring for each used port is initialized on that core. `pipeline_stage()` on core X dequeues packets from core X-1's rings and enqueue them on its own rings. See Fig. 23.3.

```

/* Start pipeline_stage() on all the available slave lcore but the last */
for (lcore_id = 0 ; lcore_id < last_lcore_id; lcore_id++) {
    if (rte_lcore_is_enabled(lcore_id) && lcore_id != master_lcore_id) {
        for (port_id = 0; port_id < RTE_MAX_ETHPORTS; port_id++)
            if (is_bit_set(port_id, portmask))
                init_ring(lcore_id, port_id);

        rte_eal_remote_launch(pipeline_stage, NULL, lcore_id);
    }
}

```

The last available logical core runs `send_stage()`, which is the last stage of the pipeline dequeuing packets from the last ring in the pipeline and sending them out on the destination port setup by `pair_ports()`.

```

/* Start send_stage() on the last slave core */
rte_eal_remote_launch(send_stage, NULL, last_lcore_id);

```

## Receive, Process and Transmit Packets

In the `receive_stage()` function running on the master logical core, the main task is to read ingress packets from the RX ports and enqueue them on the port's corresponding first ring in the pipeline. This is done using the following code:

```

lcore_id = rte_lcore_id();

/* Process each port round robin style */
for (port_id = 0; port_id < RTE_MAX_ETHPORTS; port_id++) {
    if (!is_bit_set(port_id, portmask))
        continue;

    ring = rings[lcore_id][port_id];

    if (ring_state[port_id] != RING_READY) {
        if (rte_ring_count(ring) > *low_watermark)
            continue;
        else
            ring_state[port_id] = RING_READY;
    }

    /* Enqueue received packets on the RX ring */

    nb_rx_pkts = rte_eth_rx_burst(port_id, 0, pkts, *quota);

    ret = rte_ring_enqueue_bulk(ring, (void *) pkts, nb_rx_pkts);
    if (ret == -EDQUOT) {
        ring_state[port_id] = RING_OVERLOADED;
    }
}

```

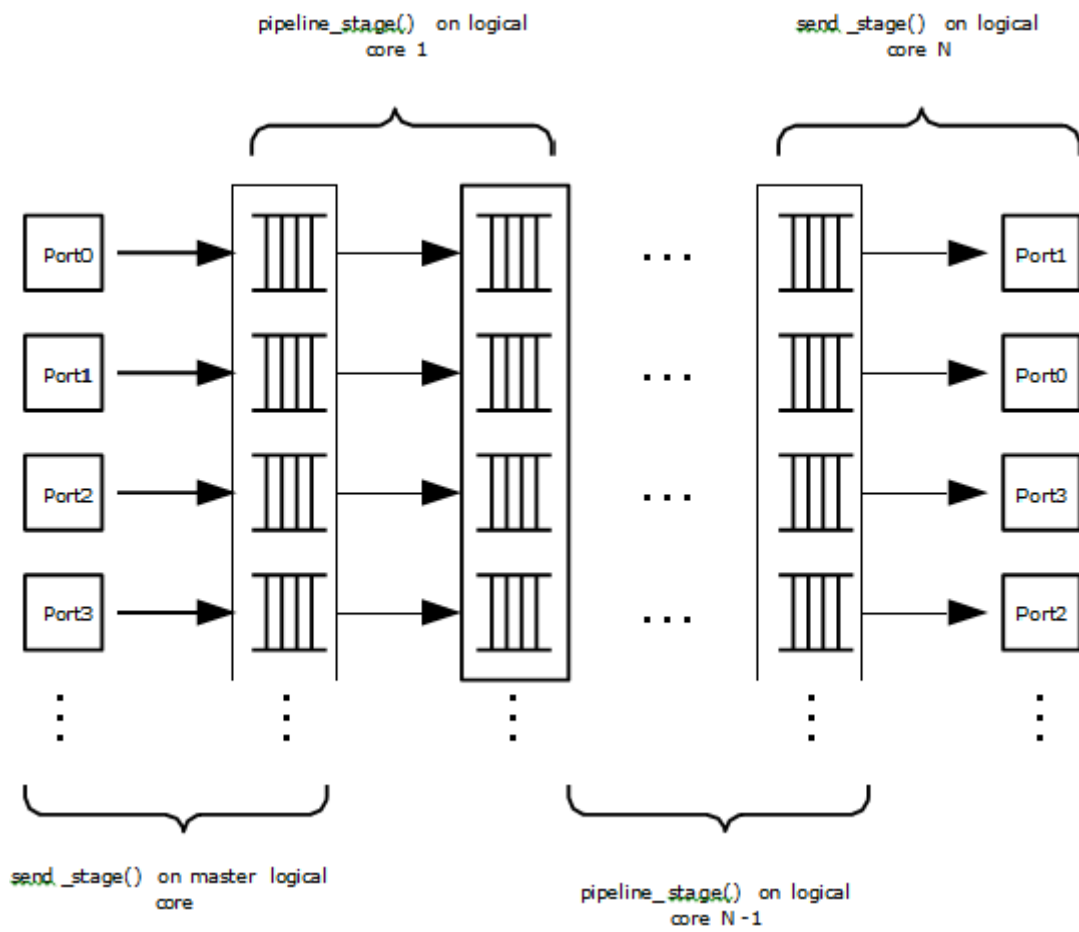

Figure 23.3: Threads and Pipelines

```

        send_pause_frame(port_id, 1337);
    }
}

```

For each port in the port mask, the corresponding ring's pointer is fetched into ring and that ring's state is checked:

- If it is in the RING\_READY state, \*quota packets are grabbed from the port and put on the ring. Should this operation make the ring's usage cross its high watermark, the ring is marked as overloaded and an Ethernet flow control frame is sent to the source.
- If it is not in the RING\_READY state, this port is ignored until the ring's usage crosses the \*low\_watermark value.

The pipeline\_stage() function's task is to process and move packets from the preceding pipeline stage. This thread is running on most of the logical cores to create and arbitrarily long pipeline.

```

lcore_id = rte_lcore_id();
previous_lcore_id = get_previous_lcore_id(lcore_id);
for (port_id = 0; port_id < RTE_MAX_ETHPORTS; port_id++) {
    if (!is_bit_set(port_id, portmask))
        continue;

    tx = rings[lcore_id][port_id];
    rx = rings[previous_lcore_id][port_id];
    if (ring_state[port_id] != RING_READY) {
        if (rte_ring_count(tx) > *low_watermark)
            continue;
    }
    else
        ring_state[port_id] = RING_READY;
}

/* Dequeue up to quota mbuf from rx */
nb_dq_pkts = rte_ring_dequeue_burst(rx, pkts, *quota);

if (unlikely(nb_dq_pkts < 0))
    continue;

/* Enqueue them on tx */
ret = rte_ring_enqueue_bulk(tx, pkts, nb_dq_pkts);
if (ret == -EDQUOT)
    ring_state[port_id] = RING_OVERLOADED;
}

```

The thread's logic works mostly like receive\_stage(), except that packets are moved from ring to ring instead of port to ring.

In this example, no actual processing is done on the packets, but pipeline\_stage() is an ideal place to perform any processing required by the application.

Finally, the send\_stage() function's task is to read packets from the last ring in a pipeline and send them on the destination port defined in the port\_pairs[] array. It is running on the last available logical core only.

```

lcore_id = rte_lcore_id();
previous_lcore_id = get_previous_lcore_id(lcore_id);

```



```

for (port_id = 0; port_id < RTE_MAX_ETHPORTS; port_id++) {
    if (!is_bit_set(port_id, portmask)) continue;

    dest_port_id = port_pairs[port_id];
    tx = rings[previous_lcore_id][port_id];

    if (rte_ring_empty(tx)) continue;

    /* Dequeue packets from tx and send them */

    nb_dq_pkts = rte_ring_dequeue_burst(tx, (void *) tx_pkts, *quota);
    nb_tx_pkts = rte_eth_tx_burst(dest_port_id, 0, tx_pkts, nb_dq_pkts);
}

```

For each port in the port mask, up to \*quota packets are pulled from the last ring in its pipeline and sent on the destination port paired with the current port.

### 23.4.2 Control Application - qwctl

The qwctl application uses the rte\_cmdline library to provide the user with an interactive command line that can be used to modify and inspect parameters in a running qw application. Those parameters are the global quota and low\_watermark value as well as each ring's built-in high watermark.

#### Command Definitions

The available commands are defined in commands.c.

It is advised to use the cmdline sample application user guide as a reference for everything related to the rte\_cmdline library.

#### Accessing Shared Variables

The setup\_shared\_variables() function retrieves the shared variables quota and low\_watermark from the rte\_memzone previously created by qw.

```

static void
setup_shared_variables(void)
{
    const struct rte_memzone *qw_memzone;

    qw_memzone = rte_memzone_lookup(QUOTA_WATERMARK_MEMZONE_NAME);
    if (qw_memzone == NULL)
        rte_exit(EXIT_FAILURE, "Couldn't find memzone\n");

    quota = qw_memzone->addr;

    low_watermark = (unsigned int *) qw_memzone->addr + sizeof(int);
}

```

## TIMER SAMPLE APPLICATION

The Timer sample application is a simple application that demonstrates the use of a timer in a DPDK application. This application prints some messages from different lcores regularly, demonstrating the use of timers.

### 24.1 Compiling the Application

1. Go to the example directory:

```
export RTE_SDK=/path/to/rte_sdk cd ${RTE_SDK}/examples/timer
```

2. Set the target (a default target is used if not specified). For example:

```
export RTE_TARGET=x86_64-native-linuxapp-gcc
```

See the *DPDK Getting Started Guide* for possible *RTE\_TARGET* values.

3. Build the application:

```
make
```

### 24.2 Running the Application

To run the example in linuxapp environment:

```
$ ./build/timer -c f -n 4
```

Refer to the *DPDK Getting Started Guide* for general information on running applications and the Environment Abstraction Layer (EAL) options.

### 24.3 Explanation

The following sections provide some explanation of the code.

#### 24.3.1 Initialization and Main Loop

In addition to EAL initialization, the timer subsystem must be initialized, by calling the `rte_timer_subsystem_init()` function.

```

/* init EAL */

ret = rte_eal_init(argc, argv);
if (ret < 0)
    rte_panic("Cannot init EAL\n");

/* init RTE timer library */

rte_timer_subsystem_init();

```

After timer creation (see the next paragraph), the main loop is executed on each slave lcore using the well-known `rte_eal_remote_launch()` and also on the master.

```

/* call lcore_mainloop() on every slave lcore */

RTE_LCORE_FOREACH_SLAVE(lcore_id) {
    rte_eal_remote_launch(lcore_mainloop, NULL, lcore_id);
}

/* call it on master lcore too */

(void) lcore_mainloop(NULL);

```

The main loop is very simple in this example:

```

while (1) {
    /*
     * Call the timer handler on each core: as we don't
     * need a very precise timer, so only call
     * rte_timer_manage() every ~10ms (at 2 GHz). In a real
     * application, this will enhance performances as
     * reading the HPET timer is not efficient.
     */

    cur_tsc = rte_rdtsc();

    diff_tsc = cur_tsc - prev_tsc;

    if (diff_tsc > TIMER_RESOLUTION_CYCLES) {
        rte_timer_manage();
        prev_tsc = cur_tsc;
    }
}

```

As explained in the comment, it is better to use the TSC register (as it is a per-lcore register) to check if the `rte_timer_manage()` function must be called or not. In this example, the resolution of the timer is 10 milliseconds.

### 24.3.2 Managing Timers

In the `main()` function, the two timers are initialized. This call to `rte_timer_init()` is necessary before doing any other operation on the timer structure.

```

/* init timer structures */

rte_timer_init(&timer0);
rte_timer_init(&timer1);

```

Then, the two timers are configured:

- The first timer (timer0) is loaded on the master lcore and expires every second. Since the PERIODICAL flag is provided, the timer is reloaded automatically by the timer subsystem. The callback function is timer0\_cb().
- The second timer (timer1) is loaded on the next available lcore every 333 ms. The SINGLE flag means that the timer expires only once and must be reloaded manually if required. The callback function is timer1\_cb().

```
/* load timer0, every second, on master lcore, reloaded automatically */
hz = rte_get_hpet_hz();
lcore_id = rte_lcore_id();
rte_timer_reset(&timer0, hz, PERIODICAL, lcore_id, timer0_cb, NULL);
/* load timer1, every second/3, on next lcore, reloaded manually */
lcore_id = rte_get_next_lcore(lcore_id, 0, 1);
rte_timer_reset(&timer1, hz/3, SINGLE, lcore_id, timer1_cb, NULL);
```

The callback for the first timer (timer0) only displays a message until a global counter reaches 20 (after 20 seconds). In this case, the timer is stopped using the rte\_timer\_stop() function.

```
/* timer0 callback */
static void
timer0_cb( attribute ((unused)) struct rte_timer *tim, __attribute ((unused)) void *arg)
{
    static unsigned counter = 0;

    unsigned lcore_id = rte_lcore_id();

    printf("%s() on lcore %u\n", FUNCTION, lcore_id);

    /* this timer is automatically reloaded until we decide to stop it, when counter reaches 20 */

    if ((counter++) == 20)
        rte_timer_stop(tim);
}
```

The callback for the second timer (timer1) displays a message and reloads the timer on the next lcore, using the rte\_timer\_reset() function:

```
/* timer1 callback */
static void
timer1_cb( attribute ((unused)) struct rte_timer *tim, __attribute ((unused)) void *arg)
{
    unsigned lcore_id = rte_lcore_id();
    uint64_t hz;

    printf("%s() on lcore %u\n", FUNCTION, lcore_id);

    /* reload it on another lcore */

    hz = rte_get_hpet_hz();

    lcore_id = rte_get_next_lcore(lcore_id, 0, 1);
```

```
    rte_timer_reset(&timer1, hz/3, SINGLE, lcore_id, timer1_cb, NULL);  
}
```

## PACKET ORDERING APPLICATION

The Packet Ordering sample app simply shows the impact of reordering a stream. It's meant to stress the library with different configurations for performance.

### 25.1 Overview

The application uses at least three CPU cores:

- RX core (maser core) receives traffic from the NIC ports and feeds Worker cores with traffic through SW queues.
- Worker core (slave core) basically do some light work on the packet. Currently it modifies the output port of the packet for configurations with more than one port enabled.
- TX Core (slave core) receives traffic from Worker cores through software queues, inserts out-of-order packets into reorder buffer, extracts ordered packets from the reorder buffer and sends them to the NIC ports for transmission.

### 25.2 Compiling the Application

1. Go to the example directory:

```
export RTE_SDK=/path/to/rte_sdk
cd ${RTE_SDK}/examples/helloworld
```

2. Set the target (a default target is used if not specified). For example:

```
export RTE_TARGET=x86_64-native-linuxapp-gcc
```

See the *DPDK Getting Started Guide* for possible RTE\_TARGET values.

3. Build the application:

```
make
```

### 25.3 Running the Application

Refer to *DPDK Getting Started Guide* for general information on running applications and the Environment Abstraction Layer (EAL) options.

### 25.3.1 Application Command Line

The application execution command line is:

```
./test-pipeline [EAL options] -- -p PORTMASK [--disable-reorder]
```

The `-c EAL CPU_COREMASK` option has to contain at least 3 CPU cores. The first CPU core in the core mask is the master core and would be assigned to RX core, the last to TX core and the rest to Worker cores.

The `PORTMASK` parameter must contain either 1 or even enabled port numbers. When setting more than 1 port, traffic would be forwarded in pairs. For example, if we enable 4 ports, traffic from port 0 to 1 and from 1 to 0, then the other pair from 2 to 3 and from 3 to 2, having [0,1] and [2,3] pairs.

The `disable-reorder` long option does, as its name implies, disable the reordering of traffic, which should help evaluate reordering performance impact.

## VMDQ AND DCB FORWARDING SAMPLE APPLICATION

The VMDQ and DCB Forwarding sample application is a simple example of packet processing using the DPDK. The application performs L2 forwarding using VMDQ and DCB to divide the incoming traffic into 128 queues. The traffic splitting is performed in hardware by the VMDQ and DCB features of the Intel® 82599 10 Gigabit Ethernet Controller.

### 26.1 Overview

This sample application can be used as a starting point for developing a new application that is based on the DPDK and uses VMDQ and DCB for traffic partitioning.

The VMDQ and DCB filters work on VLAN traffic to divide the traffic into 128 input queues on the basis of the VLAN ID field and VLAN user priority field. VMDQ filters split the traffic into 16 or 32 groups based on the VLAN ID. Then, DCB places each packet into one of either 4 or 8 queues within that group, based upon the VLAN user priority field.

In either case, 16 groups of 8 queues, or 32 groups of 4 queues, the traffic can be split into 128 hardware queues on the NIC, each of which can be polled individually by a DPDK application.

All traffic is read from a single incoming port (port 0) and output on port 1, without any processing being performed. The traffic is split into 128 queues on input, where each thread of the application reads from multiple queues. For example, when run with 8 threads, that is, with the `-c FF` option, each thread receives and forwards packets from 16 queues.

As supplied, the sample application configures the VMDQ feature to have 16 pools with 8 queues each as indicated in Fig. 26.1. The Intel® 82599 10 Gigabit Ethernet Controller NIC also supports the splitting of traffic into 32 pools of 4 queues each and this can be used by changing the `NUM_POOLS` parameter in the supplied code. The `NUM_POOLS` parameter can be passed on the command line, after the EAL parameters:

```
./build/vmdq_dcb [EAL options] -- -p PORTMASK --nb-pools NP
```

where, NP can be 16 or 32.

In Linux\* user space, the application can display statistics with the number of packets received on each queue. To have the application display the statistics, send a `SIGHUP` signal to the running application process, as follows:

where, `<pid>` is the process id of the application process.

The VMDQ and DCB Forwarding sample application is in many ways simpler than the L2 Forwarding application (see Chapter 9 , “L2 Forwarding Sample Application (in Real and Virtualized Environments)”) as it performs unidirectional L2 forwarding of packets from one port to



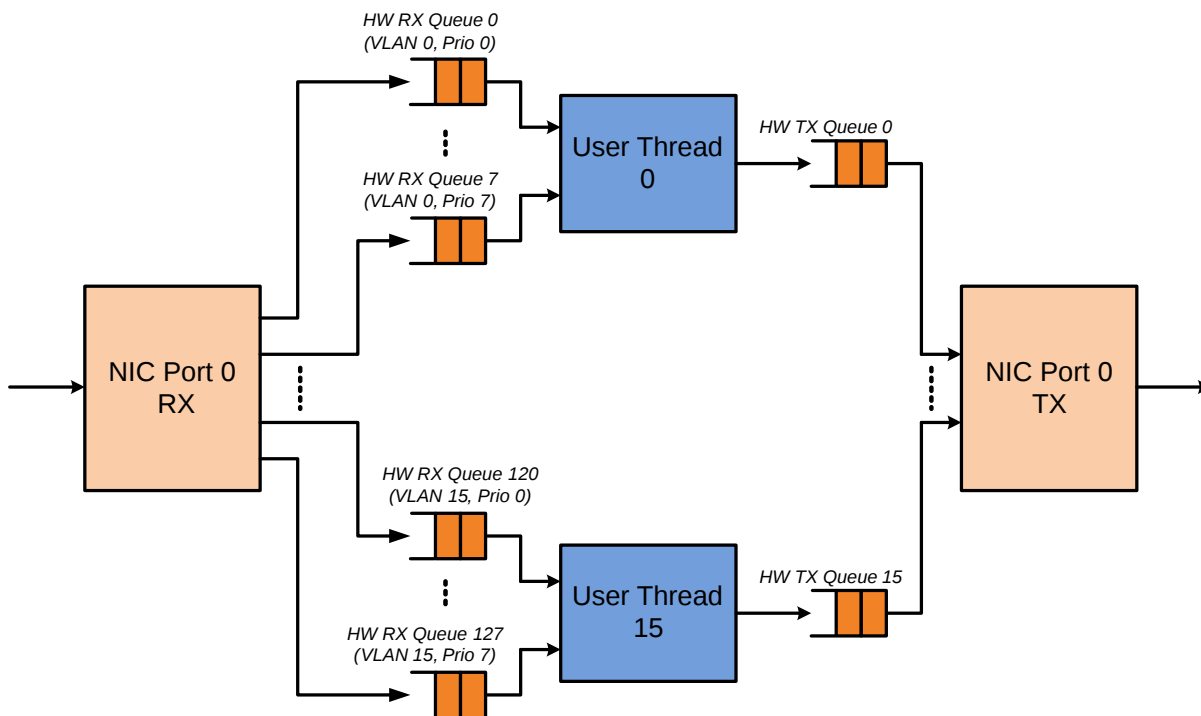

Figure 26.1: Packet Flow Through the VMDQ and DCB Sample Application

a second port. No command-line options are taken by this application apart from the standard EAL command-line options.

**Note:** Since VMD queues are being used for VMM, this application works correctly when VTd is disabled in the BIOS or Linux\* kernel (`intel_iommu=off`).

## 26.2 Compiling the Application

1. Go to the examples directory:

```
export RTE_SDK=/path/to/rte_sdk cd ${RTE_SDK}/examples/vmdq_dcb
```

2. Set the target (a default target is used if not specified). For example:

```
export RTE_TARGET=x86_64-native-linuxapp-gcc
```

See the *DPDK Getting Started Guide* for possible `RTE_TARGET` values.

3. Build the application:

```
make
```

## 26.3 Running the Application

To run the example in a linuxapp environment:

```
user@target:~$ ./build/vmdq_dcb -c f -n 4 -- -p 0x3 --nb-pools 16
```

Refer to the *DPDK Getting Started Guide* for general information on running applications and the Environment Abstraction Layer (EAL) options.

## 26.4 Explanation

The following sections provide some explanation of the code.

### 26.4.1 Initialization

The EAL, driver and PCI configuration is performed largely as in the L2 Forwarding sample application, as is the creation of the mbuf pool. See Chapter 9, “L2 Forwarding Sample Application (in Real and Virtualized Environments)”. Where this example application differs is in the configuration of the NIC port for RX.

The VMDQ and DCB hardware feature is configured at port initialization time by setting the appropriate values in the `rte_eth_conf` structure passed to the `rte_eth_dev_configure()` API. Initially in the application, a default structure is provided for VMDQ and DCB configuration to be filled in later by the application.

```

/* empty vmdq+dcb configuration structure. Filled in programmatically */
static const struct rte_eth_conf vmdq_dcb_conf_default = {
    .rxmode = {
        .mq_mode = ETH_VMDQ_DCB,
        .split_hdr_size = 0,
        .header_split = 0,    /**< Header Split disabled */
        .hw_ip_checksum = 0, /**< IP checksum offload disabled */
        .hw_vlan_filter = 0, /**< VLAN filtering disabled */
        .jumbo_frame = 0,    /**< Jumbo Frame Support disabled */
    },

    .txmode = {
        .mq_mode = ETH_DCB_NONE,
    },

    .rx_adv_conf = {
        /*
         * should be overridden separately in code with
         * appropriate values
         */

        .vmdq_dcb_conf = {
            .nb_queue_pools = ETH_16_POOLS,
            .enable_default_pool = 0,
            .default_pool = 0,
            .nb_pool_maps = 0,
            .pool_map = {{0, 0}},
            .dcb_queue = {0},
        },
    },
};

```

The `get_eth_conf()` function fills in an `rte_eth_conf` structure with the appropriate values, based on the global `vlan_tags` array, and dividing up the possible user priority values equally among the individual queues (also referred to as traffic classes) within each pool, that is, if the number of pools is 32, then the user priority fields are allocated two to a queue. If 16 pools are used,

then each of the 8 user priority fields is allocated to its own queue within the pool. For the VLAN IDs, each one can be allocated to possibly multiple pools of queues, so the pools parameter in the `rte_eth_vmdq_dcb_conf` structure is specified as a bitmask value.

```

const uint16_t vlan_tags[] = {
    0, 1, 2, 3, 4, 5, 6, 7,
    8, 9, 10, 11, 12, 13, 14, 15,
    16, 17, 18, 19, 20, 21, 22, 23,
    24, 25, 26, 27, 28, 29, 30, 31
};

/* Builds up the correct configuration for vmdq+dcb based on the vlan tags array
 * given above, and the number of traffic classes available for use. */

static inline int
get_eth_conf(struct rte_eth_conf *eth_conf, enum rte_eth_nb_pools num_pools)
{
    struct rte_eth_vmdq_dcb_conf conf;
    unsigned i;

    if (num_pools != ETH_16_POOLS && num_pools != ETH_32_POOLS ) return -1;

    conf.nb_queue_pools = num_pools;
    conf.enable_default_pool = 0;
    conf.default_pool = 0; /* set explicit value, even if not used */
    conf.nb_pool_maps = sizeof( vlan_tags )/sizeof( vlan_tags[ 0 ]);

    for ( i = 0; i < conf.nb_pool_maps; i++){
        conf.pool_map[i].vlan_id = vlan_tags[ i ];
        conf.pool_map[i].pools = 1 << ( i % num_pools);
    }

    for ( i = 0; i < ETH_DCB_NUM_USER_PRIORITIES; i++){
        conf.dcb_queue[i] = (uint8_t)(i % (NUM_QUEUES/num_pools));
    }

    (void) rte_memcpy(eth_conf, &vmdq_dcb_conf_default, sizeof(\*eth_conf));
    (void) rte_memcpy(&eth_conf->rx_adv_conf.vmdq_dcb_conf, &conf, sizeof(eth_conf->rx_adv_conf));

    return 0;
}

```

Once the network port has been initialized using the correct VMDQ and DCB values, the initialization of the port's RX and TX hardware rings is performed similarly to that in the L2 Forwarding sample application. See Chapter 9, "L2 Forwarding Sample Application (in Real and Virtualized Environments)" for more information.

### 26.4.2 Statistics Display

When run in a linuxapp environment, the VMDQ and DCB Forwarding sample application can display statistics showing the number of packets read from each RX queue. This is provided by way of a signal handler for the SIGHUP signal, which simply prints to standard output the packet counts in grid form. Each row of the output is a single pool with the columns being the queue number within that pool.

To generate the statistics output, use the following command:

```
user@host$ sudo killall -HUP vmdq_dcb_app
```

Please note that the statistics output will appear on the terminal where the `vmdq_dcb_app` is running, rather than the terminal from which the HUP signal was sent.

## VHOST SAMPLE APPLICATION

The vhost sample application demonstrates integration of the Data Plane Development Kit (DPDK) with the Linux\* KVM hypervisor by implementing the vhost-net offload API. The sample application performs simple packet switching between virtual machines based on Media Access Control (MAC) address or Virtual Local Area Network (VLAN) tag. The splitting of Ethernet traffic from an external switch is performed in hardware by the Virtual Machine Device Queues (VMDQ) and Data Center Bridging (DCB) features of the Intel® 82599 10 Gigabit Ethernet Controller.

### 27.1 Background

Virtio networking (virtio-net) was developed as the Linux\* KVM para-virtualized method for communicating network packets between host and guest. It was found that virtio-net performance was poor due to context switching and packet copying between host, guest, and QEMU. The following figure shows the system architecture for a virtio-based networking (virtio-net).

The Linux\* Kernel vhost-net module was developed as an offload mechanism for virtio-net. The vhost-net module enables KVM (QEMU) to offload the servicing of virtio-net devices to the vhost-net kernel module, reducing the context switching and packet copies in the virtual dataplane.

This is achieved by QEMU sharing the following information with the vhost-net module through the vhost-net API:

- The layout of the guest memory space, to enable the vhost-net module to translate addresses.
- The locations of virtual queues in QEMU virtual address space, to enable the vhost module to read/write directly to and from the virtqueues.
- An event file descriptor (eventfd) configured in KVM to send interrupts to the virtio-net device driver in the guest. This enables the vhost-net module to notify (call) the guest.
- An eventfd configured in KVM to be triggered on writes to the virtio-net device's Peripheral Component Interconnect (PCI) config space. This enables the vhost-net module to receive notifications (kicks) from the guest.

The following figure shows the system architecture for virtio-net networking with vhost-net offload.

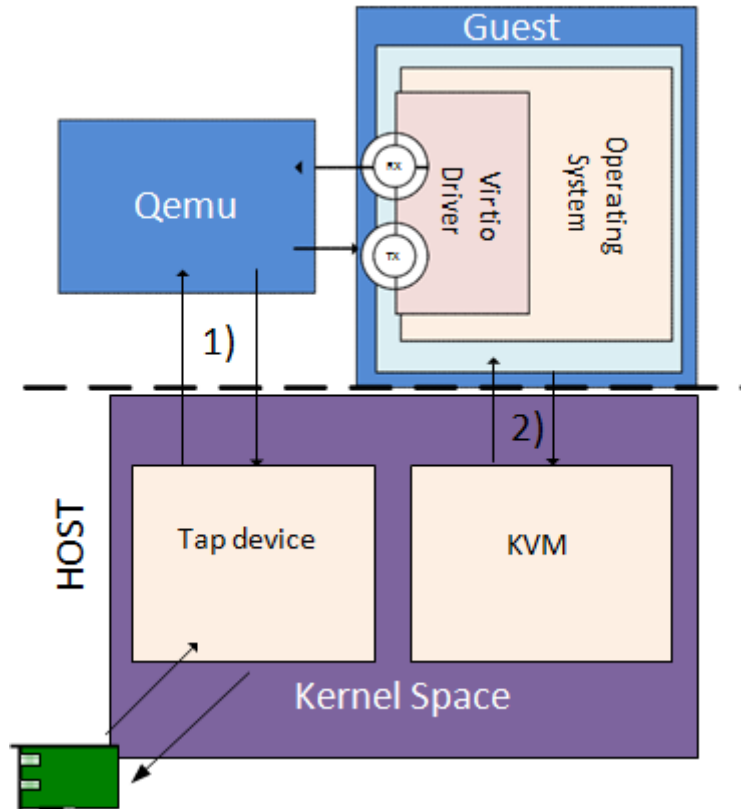

Figure 27.1: System Architecture for Virtio-based Networking (virtio-net).

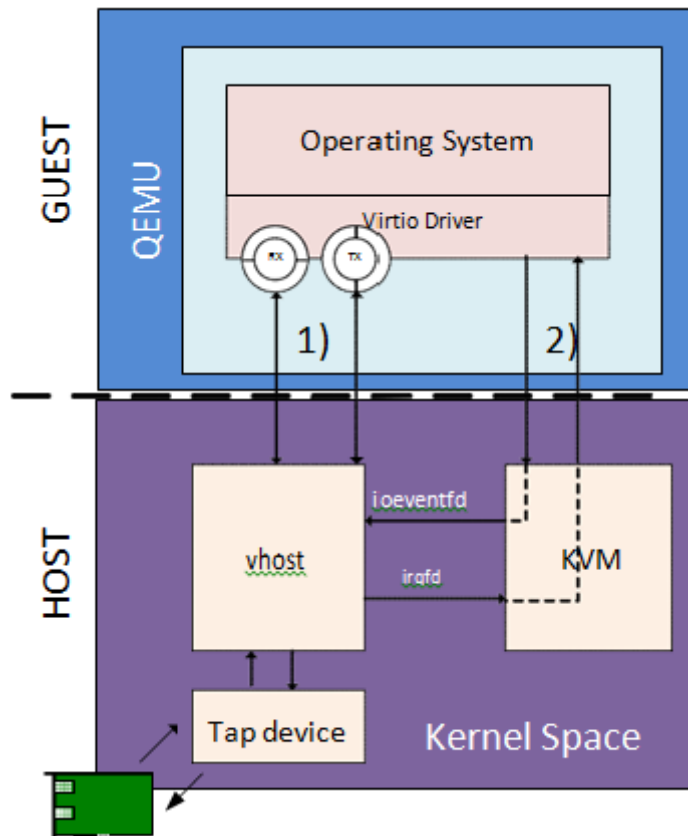

Figure 27.2: Virtio with Linux

## 27.2 Sample Code Overview

The DPDK vhost-net sample code demonstrates KVM (QEMU) offloading the servicing of a Virtual Machine's (VM's) virtio-net devices to a DPDK-based application in place of the kernel's vhost-net module.

The DPDK vhost-net sample code is based on vhost library. Vhost library is developed for user space Ethernet switch to easily integrate with vhost functionality.

The vhost library implements the following features:

- Management of virtio-net device creation/destruction events.
- Mapping of the VM's physical memory into the DPDK vhost-net's address space.
- Triggering/receiving notifications to/from VMs via eventfds.
- A virtio-net back-end implementation providing a subset of virtio-net features.

There are two vhost implementations in vhost library, vhost cuse and vhost user. In vhost cuse, a character device driver is implemented to receive and process vhost requests through ioctl messages. In vhost user, a socket server is created to received vhost requests through socket messages. Most of the messages share the same handler routine.

---

**Note:** Any vhost cuse specific requirement in the following sections will be emphasized.

---

Two implementations are turned on and off statically through configure file. Only one implementation could be turned on. They don't co-exist in current implementation.

The vhost sample code application is a simple packet switching application with the following feature:

- Packet switching between virtio-net devices and the network interface card, including using VMDQs to reduce the switching that needs to be performed in software.

The following figure shows the architecture of the Vhost sample application based on vhost-cuse.

The following figure shows the flow of packets through the vhost-net sample application.

## 27.3 Supported Distributions

The example in this section have been validated with the following distributions:

- Fedora\* 18
- Fedora\* 19
- Fedora\* 20

## 27.4 Prerequisites

This section lists prerequisite packages that must be installed.

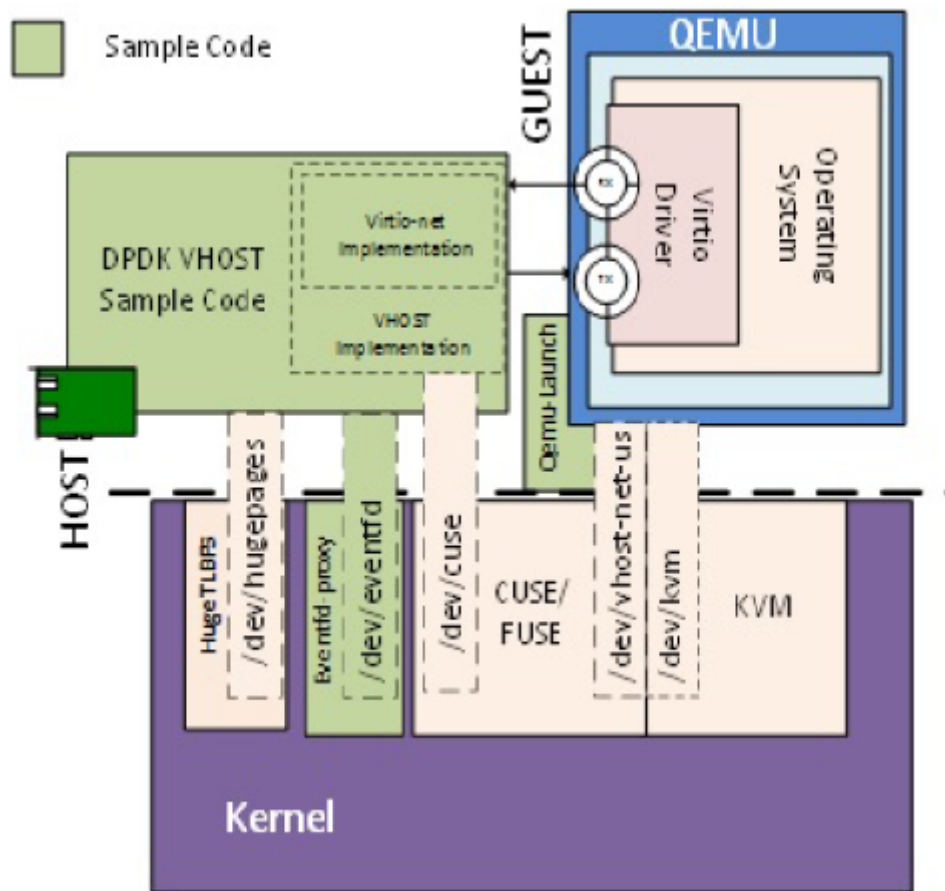

Figure 27.3: Vhost-net Architectural Overview



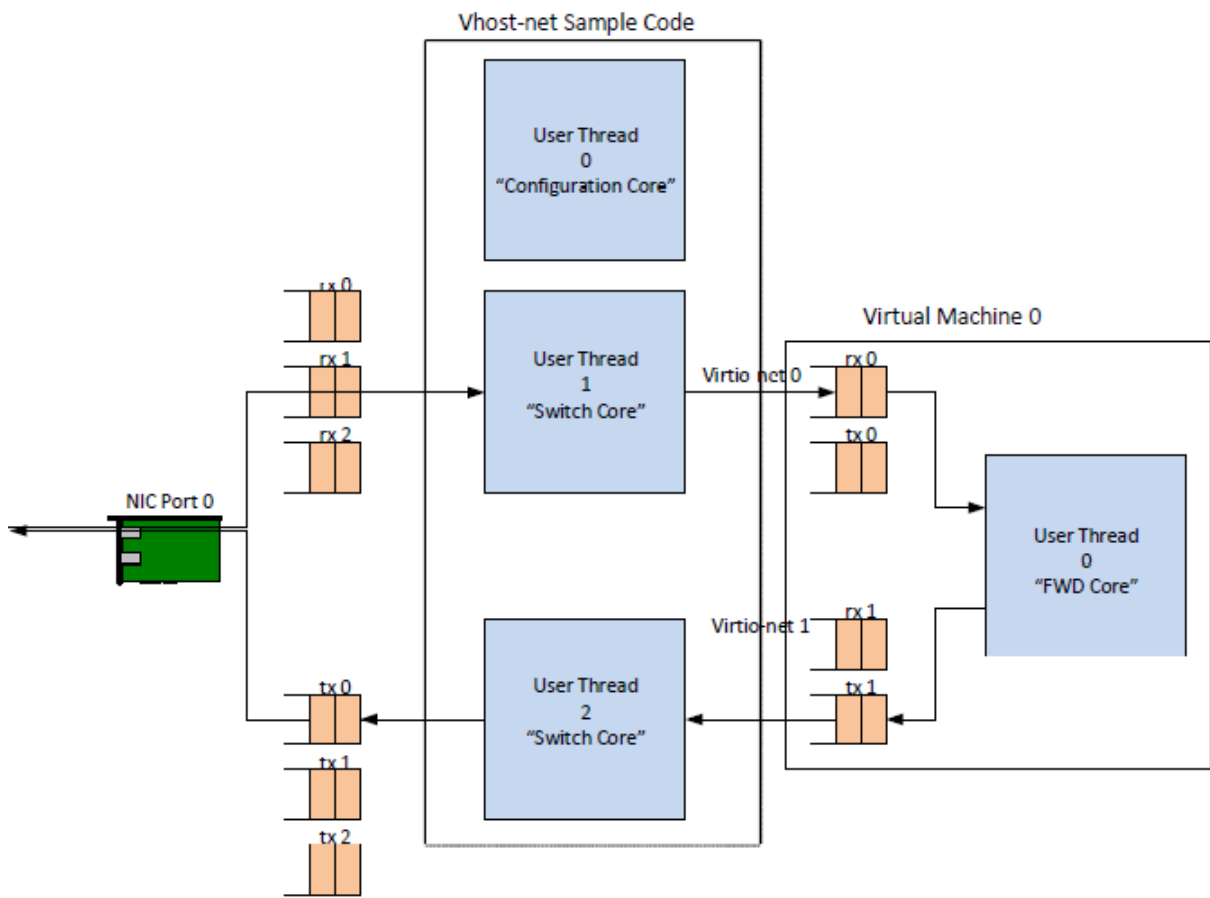

Figure 27.4: Packet Flow Through the vhost-net Sample Application

### 27.4.1 Installing Packages on the Host(vhost cuse required)

The vhost cuse code uses the following packages; fuse, fuse-devel, and kernel-modules-extra. The vhost user code don't rely on those modules as eventfds are already installed into vhost process through Unix domain socket.

1. Install Fuse Development Libraries and headers:

```
yum -y install fuse fuse-devel
```

2. Install the Cuse Kernel Module:

```
yum -y install kernel-modules-extra
```

### 27.4.2 QEMU simulator

For vhost user, qemu 2.2 is required.

### 27.4.3 Setting up the Execution Environment

The vhost sample code requires that QEMU allocates a VM's memory on the hugetlbfs file system. As the vhost sample code requires hugepages, the best practice is to partition the system into separate hugepage mount points for the VMs and the vhost sample code.

---

**Note:** This is best-practice only and is not mandatory. For systems that only support 2 MB page sizes, both QEMU and vhost sample code can use the same hugetlbfs mount point without issue.

---

#### QEMU

VMs with gigabytes of memory can benefit from having QEMU allocate their memory from 1 GB huge pages. 1 GB huge pages must be allocated at boot time by passing kernel parameters through the grub boot loader.

1. Calculate the maximum memory usage of all VMs to be run on the system. Then, round this value up to the nearest Gigabyte the execution environment will require.
2. Edit the /etc/default/grub file, and add the following to the GRUB\_CMDLINE\_LINUX entry:

```
GRUB_CMDLINE_LINUX="... hugepagesz=1G hugepages=<Number of hugepages required> default_hu
```

3. Update the grub boot loader:

```
grub2-mkconfig -o /boot/grub2/grub.cfg
```

4. Reboot the system.
5. The hugetlbfs mount point (/dev/hugepages) should now default to allocating gigabyte pages.

---

**Note:** Making the above modification will change the system default hugepage size to 1 GB for all applications.

---

## Vhost Sample Code

In this section, we create a second hugetlbs mount point to allocate hugepages for the DPDK vhost sample code.

1. Allocate sufficient 2 MB pages for the DPDK vhost sample code:

```
echo 256 > /sys/kernel/mm/hugepages/hugepages-2048kB/nr_hugepages
```

2. Mount hugetlbs at a separate mount point for 2 MB pages:

```
mount -t hugetlbfs nodev /mnt/huge -o pagesize=2M
```

The above steps can be automated by doing the following:

1. Edit /etc/fstab to add an entry to automatically mount the second hugetlbfs mount point:

```
hugetlbfs <tab> /mnt/huge <tab> hugetlbfs defaults,pagesize=1G 0 0
```

2. Edit the /etc/default/grub file, and add the following to the GRUB\_CMDLINE\_LINUX entry:

```
GRUB_CMDLINE_LINUX="... hugepagesz=2M hugepages=256 ... default_hugepagesz=1G"
```

3. Update the grub bootloader:

```
grub2-mkconfig -o /boot/grub2/grub.cfg
```

4. Reboot the system.

---

**Note:** Ensure that the default hugepage size after this setup is 1 GB.

---

### 27.4.4 Setting up the Guest Execution Environment

It is recommended for testing purposes that the DPDK testpmd sample application is used in the guest to forward packets, the reasons for this are discussed in Section [Running the Virtual Machine \(QEMU\)](#).

The testpmd application forwards packets between pairs of Ethernet devices, it requires an even number of Ethernet devices (virtio or otherwise) to execute. It is therefore recommended to create multiples of two virtio-net devices for each Virtual Machine either through libvirt or at the command line as follows.

---

**Note:** Observe that in the example, “-device” and “-netdev” are repeated for two virtio-net devices.

---

For vhost cuse:

```
user@target:~$ qemu-system-x86_64 ... \
-netdev tap,id=hostnet1,vhost=on,vhostfd=<open fd> \
-device virtio-net-pci, netdev=hostnet1,id=net1 \
-netdev tap,id=hostnet2,vhost=on,vhostfd=<open fd> \
-device virtio-net-pci, netdev=hostnet2,id=net1
```

For vhost user:

```

user@target:~$ qemu-system-x86_64 ... \
-chardev socket,id=char1,path=<sock_path> \
-netdev type=vhost-user,id=hostnet1,chardev=char1 \
-device virtio-net-pci,netdev=hostnet1,id=net1 \
-chardev socket,id=char2,path=<sock_path> \
-netdev type=vhost-user,id=hostnet2,chardev=char2 \
-device virtio-net-pci,netdev=hostnet2,id=net2

```

sock\_path is the path for the socket file created by vhost.

## 27.5 Compiling the Sample Code

### 1. Compile vhost lib:

To enable vhost, turn on vhost library in the configure file config/common\_linuxapp.

```
CONFIG_RTE_LIBRTE_VHOST=n
```

vhost user is turned on by default in the configure file config/common\_linuxapp. To enable vhost cuse, disable vhost user.

```
CONFIG_RTE_LIBRTE_VHOST_USER=y
```

After vhost is enabled and the implementation is selected, build the vhost library.

### 2. Go to the examples directory:

```
export RTE_SDK=/path/to/rte_sdk
cd ${RTE_SDK}/examples/vhost
```

### 3. Set the target (a default target is used if not specified). For example:

```
export RTE_TARGET=x86_64-native-linuxapp-gcc
```

See the DPDK Getting Started Guide for possible RTE\_TARGET values.

### 4. Build the application:

```
cd ${RTE_SDK}
make config ${RTE_TARGET}
make install ${RTE_TARGET}
cd ${RTE_SDK}/examples/vhost
make
```

### 5. Go to the eventfd\_link directory(vhost cuse required):

```
cd ${RTE_SDK}/lib/librte_vhost/eventfd_link
```

### 6. Build the eventfd\_link kernel module(vhost cuse required):

```
make
```

## 27.6 Running the Sample Code

### 1. Install the cuse kernel module(vhost cuse required):

```
modprobe cuse
```

2. Go to the eventfd\_link directory(vhost cuse required):

```
export RTE_SDK=/path/to/rte_sdk
cd ${RTE_SDK}/lib/librte_vhost/eventfd_link
```

3. Install the eventfd\_link module(vhost cuse required):

```
insmod ./eventfd_link.ko
```

4. Go to the examples directory:

```
export RTE_SDK=/path/to/rte_sdk
cd ${RTE_SDK}/examples/vhost
```

5. Run the vhost-switch sample code:

vhost cuse:

```
user@target:~$ ./build/app/vhost-switch -c f -n 4 --huge-dir /mnt/huge --p 0x1 --dev-b
```

vhost user: a socket file named usvhost will be created under current directory. Use its path as the socket path in guest's qemu commandline.

```
user@target:~$ ./build/app/vhost-switch -c f -n 4 --huge-dir /mnt/huge --p 0x1 --dev-b
```

---

**Note:** Please note the huge-dir parameter instructs the DPDK to allocate its memory from the 2 MB page hugetlbfs.

---

## 27.6.1 Parameters

**Basename and Index.** vhost cuse uses a Linux\* character device to communicate with QEMU. The basename and the index are used to generate the character devices name.

```
/dev/<basename>-<index>
```

The index parameter is provided for a situation where multiple instances of the virtual switch is required.

For compatibility with the QEMU wrapper script, a base name of "usvhost" and an index of "1" should be used:

```
user@target:~$ ./build/app/vhost-switch -c f -n 4 --huge-dir /mnt/huge --p 0x1 --dev-basena
```

**vm2vm.** The vm2vm parameter disable/set mode of packet switching between guests in the host. Value of "0" means disabling vm2vm implies that on virtual machine packet transmission will always go to the Ethernet port; Value of "1" means software mode packet forwarding between guests, it needs packets copy in vHOST, so valid only in one-copy implementation, and invalid for zero copy implementation; value of "2" means hardware mode packet forwarding between guests, it allows packets go to the Ethernet port, hardware L2 switch will determine which guest the packet should forward to or need send to external, which bases on the packet destination MAC address and VLAN tag.

```
user@target:~$ ./build/app/vhost-switch -c f -n 4 --huge-dir /mnt/huge --vm2vm [0,1,2]
```

**Mergeable Buffers.** The mergeable buffers parameter controls how virtio-net descriptors are used for virtio-net headers. In a disabled state, one virtio-net header is used per packet buffer; in an enabled state one virtio-net header is used for multiple packets. The default value is 0 or disabled since recent kernels virtio-net drivers show performance degradation with this feature is enabled.

```
user@target:~$ ./build/app/vhost-switch -c f -n 4 --huge-dir /mnt/huge -- --mergeable [0,1]
```

**Stats.** The stats parameter controls the printing of virtio-net device statistics. The parameter specifies an interval second to print statistics, with an interval of 0 seconds disabling statistics.

```
user@target:~$ ./build/app/vhost-switch -c f -n 4 --huge-dir /mnt/huge -- --stats [0,n]
```

**RX Retry.** The rx-retry option enables/disables enqueue retries when the guests RX queue is full. This feature resolves a packet loss that is observed at high data-rates, by allowing it to delay and retry in the receive path. This option is enabled by default.

```
user@target:~$ ./build/app/vhost-switch -c f -n 4 --huge-dir /mnt/huge -- --rx-retry [0,1]
```

**RX Retry Number.** The rx-retry-num option specifies the number of retries on an RX burst, it takes effect only when rx retry is enabled. The default value is 4.

```
user@target:~$ ./build/app/vhost-switch -c f -n 4 --huge-dir /mnt/huge -- --rx-retry 1 --rx-r
```

**RX Retry Delay Time.** The rx-retry-delay option specifies the timeout (in micro seconds) between retries on an RX burst, it takes effect only when rx retry is enabled. The default value is 15.

```
user@target:~$ ./build/app/vhost-switch -c f -n 4 --huge-dir /mnt/huge -- --rx-retry 1 --rx-r
```

**Zero copy.** The zero copy option enables/disables the zero copy mode for RX/TX packet, in the zero copy mode the packet buffer address from guest translate into host physical address and then set directly as DMA address. If the zero copy mode is disabled, then one copy mode is utilized in the sample. This option is disabled by default.

```
user@target:~$ ./build/app/vhost-switch -c f -n 4 --huge-dir /mnt/huge -- --zero-copy [0,1]
```

**RX descriptor number.** The RX descriptor number option specify the Ethernet RX descriptor number, Linux legacy virtio-net has different behavior in how to use the vring descriptor from DPDK based virtio-net PMD, the former likely allocate half for virtio header, another half for frame buffer, while the latter allocate all for frame buffer, this lead to different number for available frame buffer in vring, and then lead to different Ethernet RX descriptor number could be used in zero copy mode. So it is valid only in zero copy mode is enabled. The value is 32 by default.

```
user@target:~$ ./build/app/vhost-switch -c f -n 4 --huge-dir /mnt/huge -- --zero-copy 1 --rx-d
```

**TX descriptor number.** The TX descriptor number option specify the Ethernet TX descriptor number, it is valid only in zero copy mode is enabled. The value is 64 by default.

```
user@target:~$ ./build/app/vhost-switch -c f -n 4 --huge-dir /mnt/huge -- --zero-copy 1 --tx-d
```

**VLAN strip.** The VLAN strip option enable/disable the VLAN strip on host, if disabled, the guest will receive the packets with VLAN tag. It is enabled by default.

```
user@target:~$ ./build/app/vhost-switch -c f -n 4 --huge-dir /mnt/huge -- --vlan-strip [0, 1]
```

## 27.7 Running the Virtual Machine (QEMU)

QEMU must be executed with specific parameters to:

- Ensure the guest is configured to use virtio-net network adapters.

```
user@target:~$ qemu-system-x86_64 ... -device virtio-net-pci,netdev=hostnet1,id=net1 ...
```

- Ensure the guest's virtio-net network adapter is configured with offloads disabled.

```
user@target:~$ qemu-system-x86_64 ... -device virtio-net-pci,netdev=hostnet1,id=net1,csu...
```

- Redirect QEMU to communicate with the DPDK vhost-net sample code in place of the vhost-net kernel module(vhost cuse).

```
user@target:~$ qemu-system-x86_64 ... -netdev tap,id=hostnet1,vhost=on,vhostfd=<open fd>
```

- Enable the vhost-net sample code to map the VM's memory into its own process address space.

```
user@target:~$ qemu-system-x86_64 ... -mem-prealloc -mem-path / dev/hugepages ...
```

**Note:** The QEMU wrapper (qemu-wrap.py) is a Python script designed to automate the QEMU configuration described above. It also facilitates integration with libvirt, although the script may also be used standalone without libvirt.

### 27.7.1 Redirecting QEMU to vhost-net Sample Code(vhost cuse)

To redirect QEMU to the vhost-net sample code implementation of the vhost-net API, an open file descriptor must be passed to QEMU running as a child process.

```
#!/usr/bin/python
fd = os.open("/dev/uvshost-1", os.O_RDWR)
subprocess.call("qemu-system-x86_64 ... -netdev tap,id=vhostnet0,vhost=on,vhostfd=" + fd + ".
```

**Note:** This process is automated in the QEMU wrapper script described below.

### 27.7.2 Mapping the Virtual Machine's Memory

For the DPDK vhost-net sample code to be run correctly, QEMU must allocate the VM's memory on hugetlbfs. This is done by specifying mem-prealloc and mem-path when executing QEMU. The vhost-net sample code accesses the virtio-net device's virtual rings and packet buffers by finding and mapping the VM's physical memory on hugetlbfs. In this case, the path passed to the guest should be that of the 1 GB page hugetlbfs:

```
user@target:~$ qemu-system-x86_64 ... -mem-prealloc -mem-path / dev/hugepages ..
```

**Note:** This process is automated in the QEMU wrapper script described below. The following two sections only applies to vhost cuse. For vhost-user, please make corresponding changes to qemu-wrapper script and guest XML file.

### 27.7.3 QEMU Wrapper Script

The QEMU wrapper script automatically detects and calls QEMU with the necessary parameters required to integrate with the vhost sample code. It performs the following actions:

- Automatically detects the location of the hugetlbfs and inserts this into the command line parameters.
- Automatically open file descriptors for each virtio-net device and inserts this into the command line parameters.
- Disables offloads on each virtio-net device.
- Calls Qemu passing both the command line parameters passed to the script itself and those it has auto-detected.

The QEMU wrapper script will automatically configure calls to QEMU:

```
user@target:~$ qemu-wrap.py -machine pc-i440fx-1.4,accel=kvm,usb=off -cpu SandyBridge -smp 4,s
-netdev tap,id=hostnet1,vhost=on -device virtio-net-pci,netdev=hostnet1,id=net1 -hda <disk img>
```

which will become the following call to QEMU:

```
/usr/local/bin/qemu-system-x86_64 -machine pc-i440fx-1.4,accel=kvm,usb=off -cpu SandyBridge -s
-netdev tap,id=hostnet1,vhost=on,vhostfd=<open fd> -device virtio-net-pci,netdev=hostnet1,id=n
csum=off,gso=off,guest_tso4=off,guest_tso6=off,guest_ecn=off -hda <disk img> -m 4096 -mem-path
```

### 27.7.4 Libvirt Integration

The QEMU wrapper script (qemu-wrap.py) “wraps” libvirt calls to QEMU, such that QEMU is called with the correct parameters described above. To call the QEMU wrapper automatically from libvirt, the following configuration changes must be made:

- Place the QEMU wrapper script in libvirt’s binary search PATH (\$PATH). A good location is in the directory that contains the QEMU binary.
- Ensure that the script has the same owner/group and file permissions as the QEMU binary.
- Update the VM xml file using virsh edit <vm name>:
  - Set the VM to use the launch script
  - Set the emulator path contained in the #<emulator><emulator/> tags For example, replace <emulator>/usr/bin/qemu-kvm<emulator/> with <emulator>/usr/bin/qemu-wrap.py<emulator/>
  - Set the VM’s virtio-net device’s to use vhost-net offload:

```
<interface type="network">
  <model type="virtio"/>
  <driver name="vhost"/>
</interface/>
```

- Enable libvirt to access the DPDK Vhost sample code’s character device file by adding it to controllers cgroup for libvirtd using the following steps:

```
cgroup_controllers = [ ... "devices", ... ] clear_emulator_capabilities = 0
user = "root" group = "root"
```



```
cgroup_device_acl = [
    "/dev/null", "/dev/full", "/dev/zero",
    "/dev/random", "/dev/urandom",
    "/dev/ptmx", "/dev/kvm", "/dev/kqemu",
    "/dev/rtc", "/dev/hpet", "/dev/net/tun",
    "/dev/<devbase-name>-<index>",
]
```

- Disable SELinux or set to permissive mode.
- Mount cgroup device controller:

```
user@target:~$ mkdir /dev/cgroup
user@target:~$ mount -t cgroup none /dev/cgroup -o devices
```

- Restart the libvirtd system process

For example, on Fedora\* “systemctl restart libvirtd.service”

- Edit the configuration parameters section of the script:
  - Configure the “emul\_path” variable to point to the QEMU emulator.

```
emul_path = "/usr/local/bin/qemu-system-x86_64"
```

- Configure the “us\_vhost\_path” variable to point to the DPDK vhost-net sample code’s character devices name. DPDK vhost-net sample code’s character device will be in the format “/dev/<basename>-<index>”.

```
us_vhost_path = "/dev/usvhost-1"
```

### 27.7.5 Common Issues

- QEMU failing to allocate memory on hugetlbfs, with an error like the following:

```
file_ram_alloc: can't mmap RAM pages: Cannot allocate memory
```

When running QEMU the above error indicates that it has failed to allocate memory for the Virtual Machine on the hugetlbfs. This is typically due to insufficient hugepages being free to support the allocation request. The number of free hugepages can be checked as follows:

```
cat /sys/kernel/mm/hugepages/hugepages-<pagesize>/nr_hugepages
```

The command above indicates how many hugepages are free to support QEMU’s allocation request.

- User space VHOST when the guest has 2MB sized huge pages:

The guest may have 2MB or 1GB sized huge pages. The user space VHOST should work properly in both cases.

- User space VHOST will not work with QEMU without the `-mem-prealloc` option:

The current implementation works properly only when the guest memory is pre-allocated, so it is required to use a QEMU version (e.g. 1.6) which supports `-mem-prealloc`. The `-mem-prealloc` option must be specified explicitly in the QEMU command line.

- User space VHOST will not work with a QEMU version without shared memory mapping:  
As shared memory mapping is mandatory for user space VHOST to work properly with the guest, user space VHOST needs access to the shared memory from the guest to receive and transmit packets. It is important to make sure the QEMU version supports shared memory mapping.
- Issues with `virsh destroy` not destroying the VM:  
Using `libvirt virsh create` the `qemu-wrap.py` spawns a new process to run `qemu-kvm`. This impacts the behavior of `virsh destroy` which kills the process running `qemu-wrap.py` without actually destroying the VM (it leaves the `qemu-kvm` process running):  
**This following patch should fix this issue:** <http://dpdk.org/ml/archives/dev/2014-June/003607.html>
- In an Ubuntu environment, QEMU fails to start a new guest normally with user space VHOST due to not being able to allocate huge pages for the new guest:  
The solution for this issue is to add `-boot c` into the QEMU command line to make sure the huge pages are allocated properly and then the guest should start normally.  
Use `cat /proc/meminfo` to check if there is any changes in the value of `HugePages_Total` and `HugePages_Free` after the guest startup.
- Log message: `eventfd_link: module verification failed: signature and/or required key missing - tainting kernel`:  
This log message may be ignored. The message occurs due to the kernel module `eventfd_link`, which is not a standard Linux module but which is necessary for the user space VHOST current implementation (CUSE-based) to communicate with the guest.

## 27.8 Running DPDK in the Virtual Machine

For the DPDK `vhost-net` sample code to switch packets into the VM, the sample code must first learn the MAC address of the VM's `virtio-net` device. The sample code detects the address from packets being transmitted from the VM, similar to a learning switch.

This behavior requires no special action or configuration with the Linux\* `virtio-net` driver in the VM as the Linux\* Kernel will automatically transmit packets during device initialization. However, DPDK-based applications must be modified to automatically transmit packets during initialization to facilitate the DPDK `vhost-net` sample code's MAC learning.

The DPDK `testpmd` application can be configured to automatically transmit packets during initialization and to act as an L2 forwarding switch.

### 27.8.1 Testpmd MAC Forwarding

At high packet rates, a minor packet loss may be observed. To resolve this issue, a "wait and retry" mode is implemented in the `testpmd` and `vhost` sample code. In the "wait and retry" mode if the `virtqueue` is found to be full, then `testpmd` waits for a period of time before retrying to enqueue packets.

The “wait and retry” algorithm is implemented in DPDK testpmd as a forwarding method call “mac\_retry”. The following sequence diagram describes the algorithm in detail.

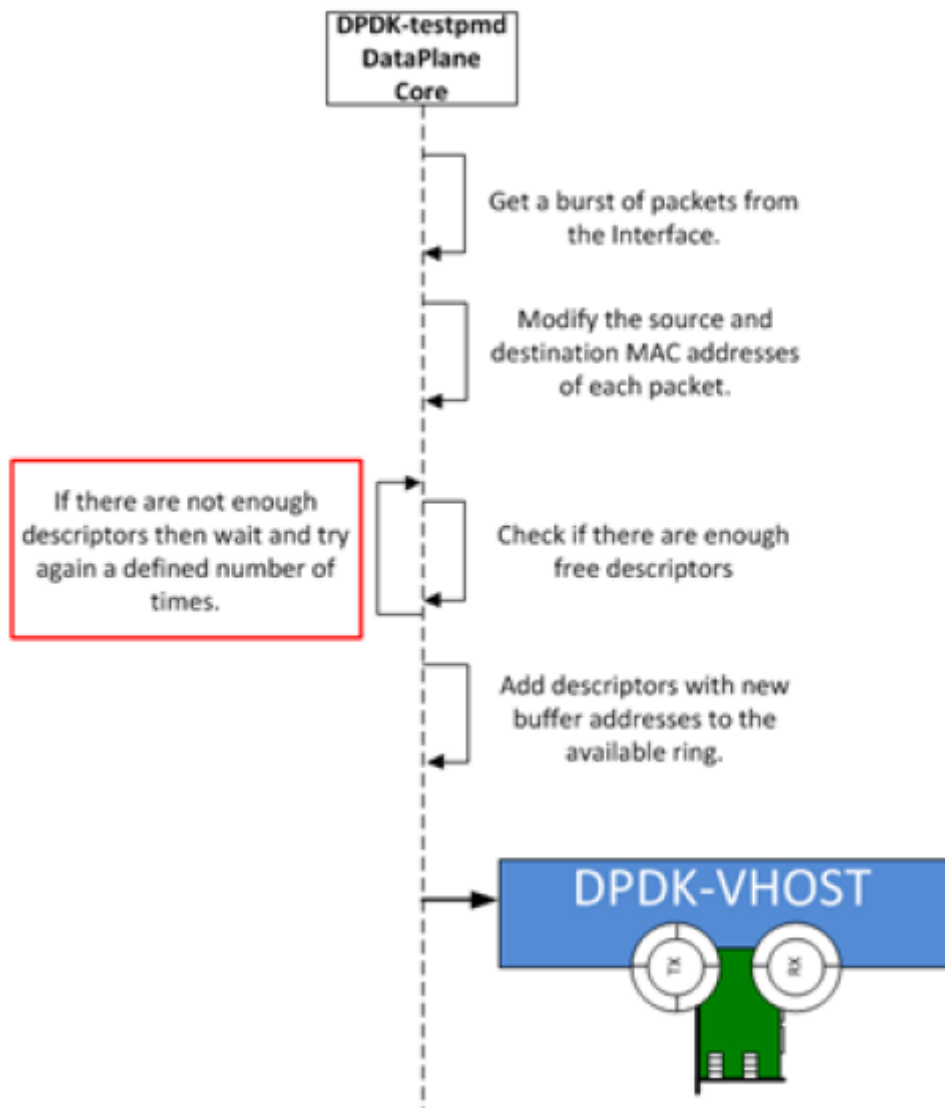

Figure 27.5: Packet Flow on TX in DPDK-testpmd

### 27.8.2 Running Testpmd

The testpmd application is automatically built when DPDK is installed. Run the testpmd application as follows:

```
user@target:~$ x86_64-native-linuxapp-gcc/app/testpmd -c 0x3 -- n 4 -socket-mem 128 -- --burst
```

The destination MAC address for packets transmitted on each port can be set at the command line:

```
user@target:~$ x86_64-native-linuxapp-gcc/app/testpmd -c 0x3 -- n 4 -socket-mem 128 -- --burst
```

- Packets received on port 1 will be forwarded on port 0 to MAC address aa:bb:cc:dd:ee:ff.

- Packets received on port 0 will be forwarded on port 1 to MAC address ff,ee,dd,cc,bb,aa.

The testpmd application can then be configured to act as an L2 forwarding application:

```
testpmd> set fwd mac_retry
```

The testpmd can then be configured to start processing packets, transmitting packets first so the DPDK vhost sample code on the host can learn the MAC address:

```
testpmd> start tx_first
```

---

**Note:** Please note “set fwd mac\_retry” is used in place of “set fwd mac\_fwd” to ensure the retry feature is activated.

---

## 27.9 Passing Traffic to the Virtual Machine Device

For a virtio-net device to receive traffic, the traffic’s Layer 2 header must include both the virtio-net device’s MAC address and VLAN tag. The DPDK sample code behaves in a similar manner to a learning switch in that it learns the MAC address of the virtio-net devices from the first transmitted packet. On learning the MAC address, the DPDK vhost sample code prints a message with the MAC address and VLAN tag virtio-net device. For example:

```
DATA: (0) MAC_ADDRESS cc:bb:bb:bb:bb:bb and VLAN_TAG 1000 registered
```

The above message indicates that device 0 has been registered with MAC address cc:bb:bb:bb:bb:bb and VLAN tag 1000. Any packets received on the NIC with these values is placed on the devices receive queue. When a virtio-net device transmits packets, the VLAN tag is added to the packet by the DPDK vhost sample code.

## NETMAP COMPATIBILITY SAMPLE APPLICATION

### 28.1 Introduction

The Netmap compatibility library provides a minimal set of APIs to give the ability to programs written against the Netmap APIs to be run with minimal changes to their source code, using the DPDK to perform the actual packet I/O.

Since Netmap applications use regular system calls, like `open()`, `ioctl()` and `mmap()` to communicate with the Netmap kernel module performing the packet I/O, the `compat_netmap` library provides a set of similar APIs to use in place of those system calls, effectively turning a Netmap application into a DPDK one.

The provided library is currently minimal and doesn't support all the features that Netmap supports, but is enough to run simple applications, such as the bridge example detailed below.

Knowledge of Netmap is required to understand the rest of this section. Please refer to the Netmap distribution for details about Netmap.

### 28.2 Available APIs

The library provides the following drop-in replacements for system calls usually used in Netmap applications: `rte_netmap_close()`

- `rte_netmap_ioctl()`
- `rte_netmap_open()`
- `rte_netmap_mmap()`
- `rte_netmap_poll()`

They use the same signature as their libc counterparts, and can be used as drop-in replacements in most cases.

### 28.3 Caveats

Given the difference between the way Netmap and the DPDK approach packet I/O, there are caveats and limitations to be aware of when trying to use the `compat_netmap` library, the most important of which are listed below. Additional caveats are presented in the `$RTE_SDK/examples/netmap_compat/README.md` file. These can change as the library is updated:

- Any system call that can potentially affect file descriptors cannot be used with a descriptor returned by the `rte_netmap_open()` function.

Note that:

- `rte_netmap_mmap()` merely returns the address of a DPDK memzone. The address, length, flags, offset, and so on arguments are therefore ignored completely.
- `rte_netmap_poll()` only supports infinite (negative) or zero time outs. It effectively turns calls to the `poll()` system call made in a Netmap application into polling of the DPDK ports, changing the semantics of the usual POSIX defined `poll`.
- Not all of Netmap's features are supported: "host rings", slot flags and so on are not supported or are simply not relevant in the DPDK model.
- The Netmap manual page states that "a device obtained through `/dev/netmap` also supports the `ioctl` supported by network devices". It is not the case with this compatibility layer.
- The Netmap kernel module exposes a `sysfs` interface to change some internal parameters, such as the size of the shared memory region. This interface is not available when using this compatibility layer.

## 28.4 Porting Netmap Applications

Porting Netmap applications typically involves two major steps:

- Changing the system calls to use their `compat_netmap` library counterparts
- Adding further DPDK initialization code

Since the `compat_netmap` functions have the same signature as the usual `libc` calls, the change is in most cases trivial.

The usual DPDK initialization code involving `rte_eal_init()` and `rte_eal_pci_probe()` has to be added to the Netmap application in the same way it is used in all other DPDK sample applications. Please refer to the *DPDK Programmer's Guide - Rel 1.4 EAR* and example source code for details about initialization.

In addition of the regular DPDK initialization code, the ported application needs to call initialization functions for the `compat_netmap` library, namely `rte_netmap_init()` and `rte_netmap_init_port()`.

These two initialization functions take `compat_netmap` specific data structures as parameters: `struct rte_netmap_conf` and `struct rte_netmap_port_conf`. Those structures' fields are Netmap related and are self-explanatory for developers familiar with Netmap. They are defined in `$RTE_SDK/examples/netmap_compat/lib/compat_netmap.h`.

The bridge application is an example largely based on the bridge example shipped with the Netmap distribution. It shows how a minimal Netmap application with minimal and straightforward source code changes can be run on top of the DPDK. Please refer to `$RTE_SDK/examples/netmap_compat/bridge/bridge.c` for an example of ported application.

## 28.5 Compiling the “bridge” Sample Application

1. Go to the example directory:

```
export RTE_SDK=/path/to/rte_sdk
cd ${RTE_SDK}/examples/netmap_compat
```

2. Set the target (a default target is used if not specified). For example:

```
export RTE_TARGET=x86_64-native-linuxapp-gcc
```

See the *DPDK Getting Started Guide* for possible RTE\_TARGET values.

3. Build the application:

```
make
```

## 28.6 Running the “bridge” Sample Application

The application requires a single command line option:

```
./build/packet_ordering [EAL options] -- -p PORT_A [-p PORT_B]
```

where,

- -p INTERFACE is the number of a valid DPDK port to use.

If a single -p parameter is given, the interface will send back all the traffic it receives. If two -p parameters are given, the two interfaces form a bridge, where traffic received on one interface is replicated and sent by the other interface.

To run the application in a linuxapp environment using port 0 and 2, issue the following command:

```
./build/packet_ordering [EAL options] -- -p 0 -p 2
```

Refer to the *DPDK Getting Started Guide* for general information on running applications and the Environment Abstraction Layer (EAL) options.

Note that unlike a traditional bridge or the l2fwd sample application, no MAC address changes are done on the frames. Do not forget to take that into account when configuring your traffic generators if you decide to test this sample application.

## INTERNET PROTOCOL (IP) PIPELINE SAMPLE APPLICATION

The Internet Protocol (IP) Pipeline application illustrates the use of the DPDK Packet Framework tool suite. The DPDK pipeline methodology is used to implement functional blocks such as packet RX, packet TX, flow classification, firewall, routing, IP fragmentation, IP reassembly, etc which are then assigned to different CPU cores and connected together to create complex multi-core applications.

### 29.1 Overview

The pipelines for packet RX, packet TX, flow classification, firewall, routing, IP fragmentation, IP reassembly, management, etc are instantiated and different CPU cores and connected together through software queues. One of the CPU cores can be designated as the management core to run a Command Line Interface (CLI) to add entries to each table (e.g. flow table, firewall rule database, routing table, Address Resolution Protocol (ARP) table, and so on), bring NIC ports up or down, and so on.

### 29.2 Compiling the Application

1. Go to the examples directory:

```
export RTE_SDK=/path/to/rte_sdk  
cd ${RTE_SDK}/examples/ip_pipeline
```

2. Set the target (a default target is used if not specified):

```
export RTE_TARGET=x86_64-native-linuxapp-gcc
```

3. Build the application:

```
make
```

### 29.3 Running the Sample Code

The application execution command line is:

```
./ip_pipeline [EAL options] -- -p PORTMASK [-f CONFIG_FILE]
```



The number of ports in the PORTMASK can be either 2 or 4.

The config file assigns functionality to the CPU core by deciding the pipeline type to run on each CPU core (e.g. master, RX, flow classification, firewall, routing, IP fragmentation, IP reassembly, TX) and also allows creating complex topologies made up of CPU cores by interconnecting the CPU cores through SW queues.

Once the application is initialized, the CLI is available for populating the application tables, bringing NIC ports up or down, and so on.

The flow classification pipeline implements the flow table by using a large (multi-million entry) hash table with a 16-byte key size. The lookup key is the IPv4 5-tuple, which is extracted from the input packet by the packet RX pipeline and saved in the packet meta-data, has the following format:

```
[source IP address, destination IP address, L4 protocol, L4 protocol source port, L4 protocol destination port]
```

The firewall pipeline implements the rule database using an ACL table.

The routing pipeline implements an IP routing table by using an LPM IPv4 table and an ARP table by using a hash table with an 8-byte key size. The IP routing table lookup provides the output interface ID and the next hop IP address, which are stored in the packet meta-data, then used as the lookup key into the ARP table. The ARP table lookup provides the destination MAC address to be used for the output packet. The action for the default entry of both the IP routing table and the ARP table is packet drop.

The following CLI operations are available:

- Enable/disable NIC ports (RX pipeline)
- Add/delete/list flows (flow classification pipeline)
- Add/delete/list firewall rules (firewall pipeline)
- Add/delete/list routes (routing pipeline)
- Add/delete/list ARP entries (routing pipeline)

In addition, there are two special commands:

- flow add all: Populate the flow classification table with 16 million flows (by iterating through the last three bytes of the destination IP address). These flows are not displayed when using the flow print command. When this command is used, the following traffic profile must be used to have flow table lookup hits for all input packets. TCP/IPv4 packets with:
  - destination IP address = A.B.C.D with A fixed to 0 and B,C,D random
  - source IP address fixed to 0
  - source TCP port fixed to 0
  - destination TCP port fixed to 0
- run cmd\_file\_path: Read CLI commands from an external file and run them one by one.

The full list of the available CLI commands can be displayed by pressing the TAB key while the application is running.

## TEST PIPELINE APPLICATION

The Test Pipeline application illustrates the use of the DPDK Packet Framework tool suite. Its purpose is to demonstrate the performance of single-table DPDK pipelines.

### 30.1 Overview

The application uses three CPU cores:

- Core A (“RX core”) receives traffic from the NIC ports and feeds core B with traffic through SW queues.
- Core B (“Pipeline core”) implements a single-table DPDK pipeline whose type is selectable through specific command line parameter. Core B receives traffic from core A through software queues, processes it according to the actions configured in the table entries that are hit by the input packets and feeds it to core C through another set of software queues.
- Core C (“TX core”) receives traffic from core B through software queues and sends it to the NIC ports for transmission.

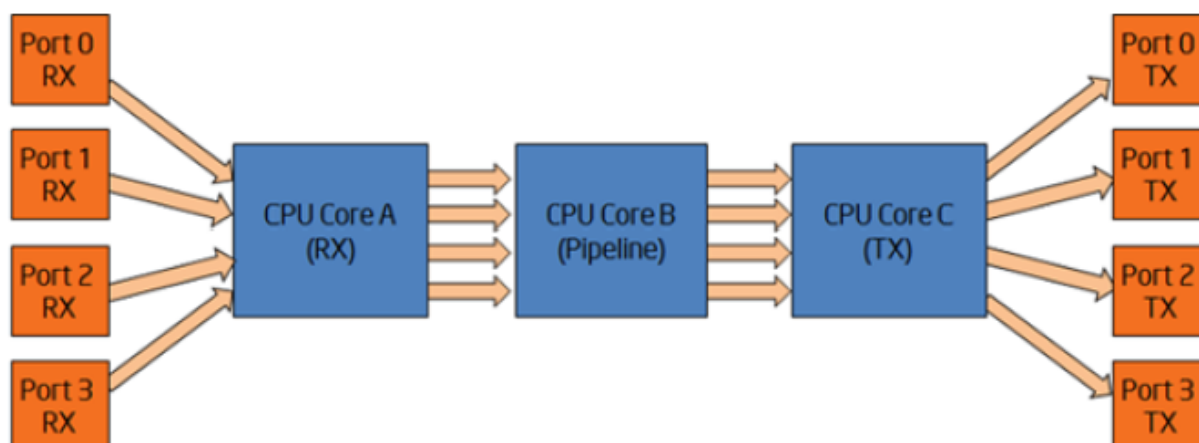

Figure 30.1: Test Pipeline Application

### 30.2 Compiling the Application

1. Go to the app/test directory:

```
export RTE_SDK=/path/to/rte_sdk
cd ${RTE_SDK}/app/test/test-pipeline
```

2. Set the target (a default target is used if not specified):

```
export RTE_TARGET=x86_64-native-linuxapp-gcc
```

3. Build the application:

```
make
```

## 30.3 Running the Application

### 30.3.1 Application Command Line

The application execution command line is:

```
./test-pipeline [EAL options] -- -p PORTMASK --TABLE_TYPE
```

The `-c` EAL CPU core mask option has to contain exactly 3 CPU cores. The first CPU core in the core mask is assigned for core A, the second for core B and the third for core C.

The `PORTMASK` parameter must contain 2 or 4 ports.

### 30.3.2 Table Types and Behavior

Table 3 describes the table types used and how they are populated.

The hash tables are pre-populated with 16 million keys. For hash tables, the following parameters can be selected:

- **Configurable key size implementation or fixed (specialized) key size implementation (e.g. `hash-8-ext` or `hash-spec-8-ext`).** The key size specialized implementations are expected to provide better performance for 8-byte and 16-byte key sizes, while the key-size-non-specialized implementation is expected to provide better performance for larger key sizes;
- **Key size (e.g. `hash-spec-8-ext` or `hash-spec-16-ext`).** The available options are 8, 16 and 32 bytes;
- **Table type (e.g. `hash-spec-16-ext` or `hash-spec-16-lru`).** The available options are `ext` (extendable bucket) or `lru` (least recently used).

Table 30.1: Table Types

#	TA-BLE_TYPE	Description of Core B Table	Pre-added Table Entries
1	none	Core B is not implementing a DPDK pipeline. Core B is implementing a pass-through from its input set of software queues to its output set of software queues.	N/A
2	stub	Stub table. Core B is implementing the same pass-through functionality as described for the “none” option by using the DPDK Packet Framework by using one stub table for each input NIC port.	N/A
3	hash-[spec]-8-lru	LRU hash table with 8-byte key size and 16 million entries.	16 million entries are successfully added to the hash table with the following key format: [4-byte index, 4 bytes of 0] The action configured for all table entries is “Send to output port”, with the output port index uniformly distributed for the range of output ports. The default table rule (used in the case of a lookup miss) is to drop the packet. At run time, core A is creating the following lookup key and storing it into the packet meta data for core B to use for table lookup: [destination IPv4 address, 4 bytes of 0]
4	hash-[spec]-8-ext	Extendable bucket hash table with 8-byte key size and 16 million entries.	Same as hash-[spec]-8-lru table entries, above.
5	hash-[spec]-16-lru	LRU hash table with 16-byte key size and 16 million entries.	16 million entries are successfully added to the hash table with the following key format: [4-byte index, 12 bytes of 0] The action configured for all table entries is “Send to output port”, with the output port index uniformly distributed for the range of output ports. The default table rule (used in the case of a lookup miss) is to drop the packet. At run time, core A is creating the following lookup key and storing it into the packet meta data for core B to use for table lookup: [destination IPv4 address, 12 bytes of 0]
<b>30.3. Running the Application</b>			
6	hash-[spec]-16-ext	Extendable bucket hash table with 16-byte key size and 16 million entries.	Same as hash-[spec]-16-lru table entries, above.

### 30.3.3 Input Traffic

Regardless of the table type used for the core B pipeline, the same input traffic can be used to hit all table entries with uniform distribution, which results in uniform distribution of packets sent out on the set of output NIC ports. The profile for input traffic is TCP/IPv4 packets with:

- destination IP address as A.B.C.D with A fixed to 0 and B, C,D random
- source IP address fixed to 0.0.0.0
- destination TCP port fixed to 0
- source TCP port fixed to 0

## DISTRIBUTOR SAMPLE APPLICATION

The distributor sample application is a simple example of packet distribution to cores using the Data Plane Development Kit (DPDK).

### 31.1 Overview

The distributor application performs the distribution of packets that are received on an RX\_PORT to different cores. When processed by the cores, the destination port of a packet is the port from the enabled port mask adjacent to the one on which the packet was received, that is, if the first four ports are enabled (port mask 0xf), ports 0 and 1 RX/TX into each other, and ports 2 and 3 RX/TX into each other.

This application can be used to benchmark performance using the traffic generator as shown in the figure below.

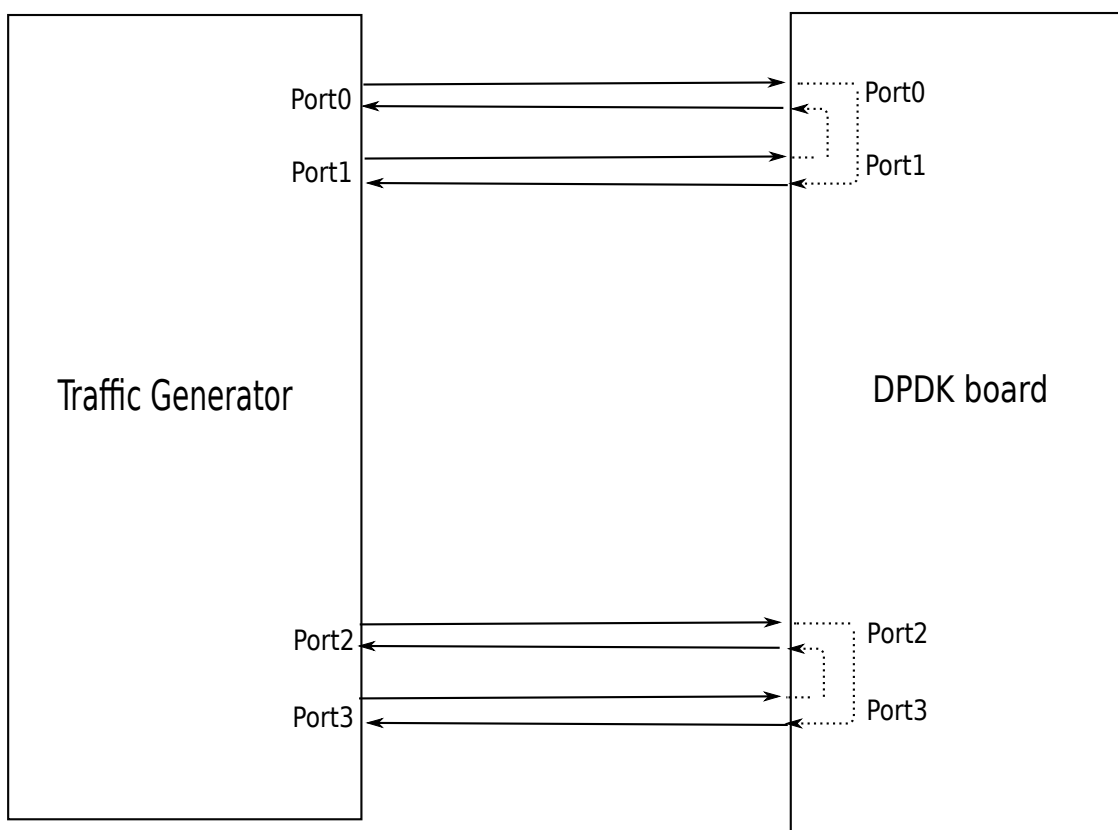

Figure 31.1: Performance Benchmarking Setup (Basic Environment)

## 31.2 Compiling the Application

1. Go to the sample application directory:

```
export RTE_SDK=/path/to/rte_sdk
cd ${RTE_SDK}/examples/distributor
```

2. Set the target (a default target is used if not specified). For example:

```
export RTE_TARGET=x86_64-native-linuxapp-gcc
```

See the DPDK Getting Started Guide for possible RTE\_TARGET values.

3. Build the application:

```
make
```

## 31.3 Running the Application

1. The application has a number of command line options:

```
./build/distributor_app [EAL options] -- -p PORTMASK
```

where,

- -p PORTMASK: Hexadecimal bitmask of ports to configure

2. To run the application in linuxapp environment with 10 lcores, 4 ports, issue the command:

```
$ ./build/distributor_app -c 0x4003fe -n 4 -- -p f
```

3. Refer to the DPDK Getting Started Guide for general information on running applications and the Environment Abstraction Layer (EAL) options.

## 31.4 Explanation

The distributor application consists of three types of threads: a receive thread (`lcore_rx()`), a set of worker threads (`lcore_worker()`) and a transmit thread (`lcore_tx()`). How these threads work together is shown in Fig. 31.2 below. The `main()` function launches threads of these three types. Each thread has a while loop which will be doing processing and which is terminated only upon SIGINT or ctrl+C. The receive and transmit threads communicate using a software ring (`rte_ring` structure).

The receive thread receives the packets using `rte_eth_rx_burst()` and gives them to the distributor (using `rte_distributor_process()` API) which will be called in context of the receive thread itself. The distributor distributes the packets to workers threads based on the tagging of the packet - indicated by the hash field in the mbuf. For IP traffic, this field is automatically filled by the NIC with the “usr” hash value for the packet, which works as a per-flow tag.

More than one worker thread can exist as part of the application, and these worker threads do simple packet processing by requesting packets from the distributor, doing a simple XOR operation on the input port mbuf field (to indicate the output port which will be used later for

packet transmission) and then finally returning the packets back to the distributor in the RX thread.

Meanwhile, the receive thread will call the distributor api `rte_distributor_returned_pkts()` to get the packets processed, and will enqueue them to a ring for transfer to the TX thread for transmission on the output port. The transmit thread will dequeue the packets from the ring and transmit them on the output port specified in packet mbuf.

Users who wish to terminate the running of the application have to press `ctrl+C` (or send `SIGINT` to the app). Upon this signal, a signal handler provided in the application will terminate all running threads gracefully and print final statistics to the user.

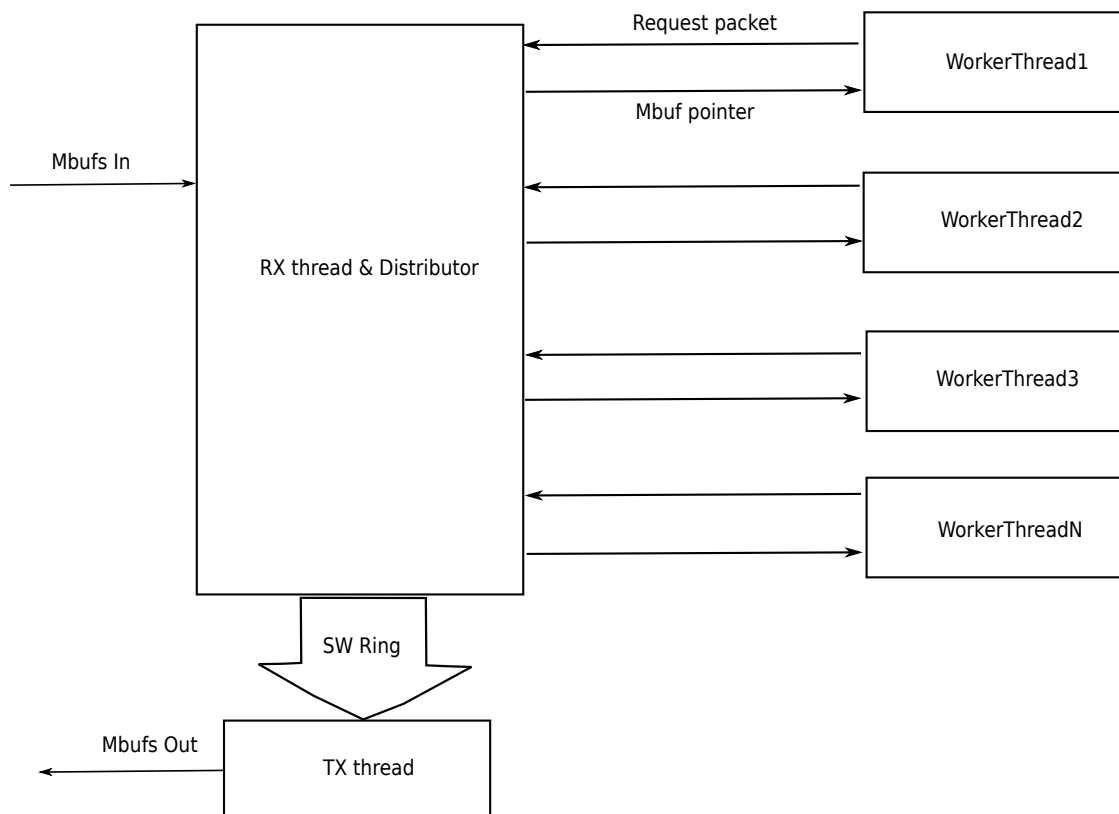

Figure 31.2: Distributor Sample Application Layout

## 31.5 Debug Logging Support

Debug logging is provided as part of the application; the user needs to uncomment the line `#define DEBUG` defined in start of the application in `main.c` to enable debug logs.

## 31.6 Statistics

Upon `SIGINT` (or) `ctrl+C`, the `print_stats()` function displays the count of packets processed at the different stages in the application.



## 31.7 Application Initialization

Command line parsing is done in the same way as it is done in the L2 Forwarding Sample Application. See Section *Command Line Arguments*.

Mbuf pool initialization is done in the same way as it is done in the L2 Forwarding Sample Application. See Section *Mbuf Pool Initialization*.

Driver Initialization is done in same way as it is done in the L2 Forwarding Sample Application. See Section *Driver Initialization*.

RX queue initialization is done in the same way as it is done in the L2 Forwarding Sample Application. See Section *RX Queue Initialization*.

TX queue initialization is done in the same way as it is done in the L2 Forwarding Sample Application. See Section *RX Queue Initialization*.

## VM POWER MANAGEMENT APPLICATION

### 32.1 Introduction

Applications running in Virtual Environments have an abstract view of the underlying hardware on the Host, in particular applications cannot see the binding of virtual to physical hardware. When looking at CPU resourcing, the pinning of Virtual CPUs(vCPUs) to Host Physical CPUs(pCPUS) is not apparent to an application and this pinning may change over time. Furthermore, Operating Systems on virtual machines do not have the ability to govern their own power policy; the Machine Specific Registers (MSRs) for enabling P-State transitions are not exposed to Operating Systems running on Virtual Machines(VMs).

The Virtual Machine Power Management solution shows an example of how a DPDK application can indicate its processing requirements using VM local only information(vCPU/lcore) to a Host based Monitor which is responsible for accepting requests for frequency changes for a vCPU, translating the vCPU to a pCPU via libvirt and affecting the change in frequency.

The solution is comprised of two high-level components:

1. Example Host Application

Using a Command Line Interface(CLI) for VM->Host communication channel management allows adding channels to the Monitor, setting and querying the vCPU to pCPU pinning, inspecting and manually changing the frequency for each CPU. The CLI runs on a single lcore while the thread responsible for managing VM requests runs on a second lcore.

VM requests arriving on a channel for frequency changes are passed to the `librte_power ACPI cpufreq sysfs` based library. The Host Application relies on both `qemu-kvm` and `libvirt` to function.

2. `librte_power` for Virtual Machines

Using an alternate implementation for the `librte_power` API, requests for frequency changes are forwarded to the host monitor rather than the `ACPI cpufreq sysfs` interface used on the host.

The `l3fwd-power` application will use this implementation when deployed on a VM (see Chapter 11 “L3 Forwarding with Power Management Application”).

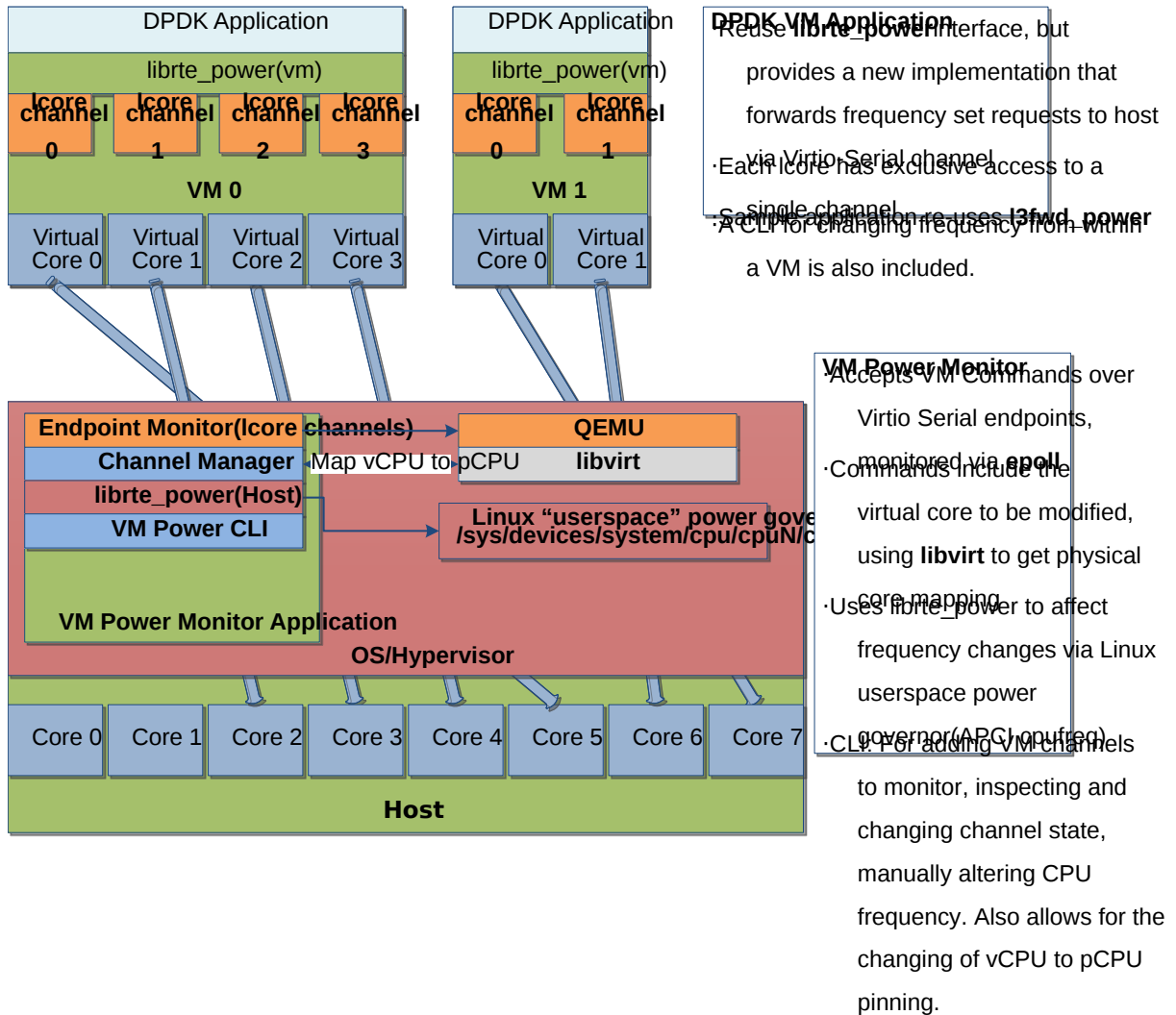

Figure 32.1: Highlevel Solution

## 32.2 Overview

VM Power Management employs qemu-kvm to provide communications channels between the host and VMs in the form of Virtio-Serial which appears as a paravirtualized serial device on a VM and can be configured to use various backends on the host. For this example each Virtio-Serial endpoint on the host is configured as AF\_UNIX file socket, supporting poll/select and epoll for event notification. In this example each channel endpoint on the host is monitored via epoll for EPOLLIN events. Each channel is specified as qemu-kvm arguments or as libvirt XML for each VM, where each VM can have a number of channels up to a maximum of 64 per VM, in this example each DPDK lcore on a VM has exclusive access to a channel.

To enable frequency changes from within a VM, a request via the `librte_power` interface is forwarded via Virtio-Serial to the host, each request contains the vCPU and power command (scale up/down/min/max). The API for host and guest `librte_power` is consistent across environments, with the selection of VM or Host Implementation determined at automatically at runtime based on the environment.

Upon receiving a request, the host translates the vCPU to a pCPU via the libvirt API before forwarding to the host `librte_power`.

# Sequence

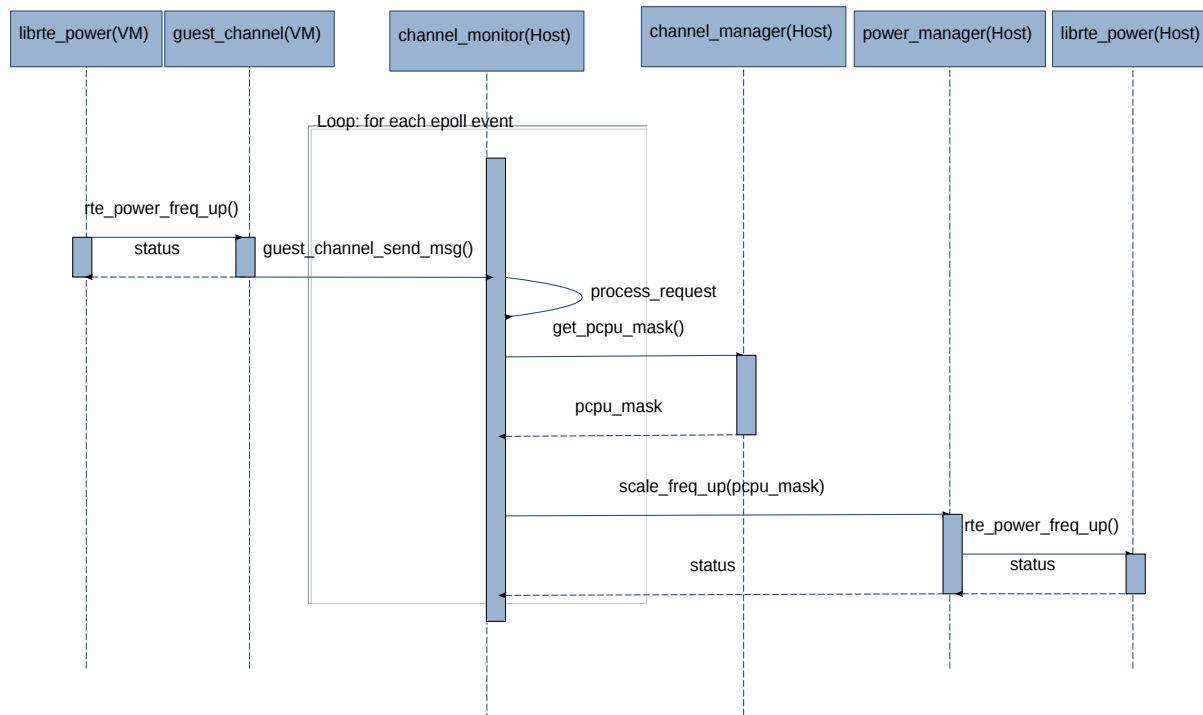

Figure 32.2: VM request to scale frequency

### 32.2.1 Performance Considerations

While Haswell Microarchitecture allows for independent power control for each core, earlier Microarchitectures do not offer such fine grained control. When deployed on pre-Haswell plat-

forms greater care must be taken in selecting which cores are assigned to a VM, for instance a core will not scale down until its sibling is similarly scaled.

## 32.3 Configuration

### 32.3.1 BIOS

Enhanced Intel SpeedStep® Technology must be enabled in the platform BIOS if the power management feature of DPDK is to be used. Otherwise, the sys file folder `/sys/devices/system/cpu/cpu0/cpufreq` will not exist, and the CPU frequency-based power management cannot be used. Consult the relevant BIOS documentation to determine how these settings can be accessed.

### 32.3.2 Host Operating System

The Host OS must also have the `acpi_cpufreq` module installed, in some cases the `intel_pstate` driver may be the default Power Management environment. To enable `acpi_cpufreq` and disable `intel_pstate`, add the following to the grub Linux command line:

```
intel_pstate=disable
```

Upon rebooting, load the `acpi_cpufreq` module:

```
modprobe acpi_cpufreq
```

### 32.3.3 Hypervisor Channel Configuration

Virtio-Serial channels are configured via libvirt XML:

```
<name>{vm_name}</name>
<controller type='virtio-serial' index='0'>
  <address type='pci' domain='0x0000' bus='0x00' slot='0x06' function='0x0' />
</controller>
<channel type='unix'>
  <source mode='bind' path='/tmp/powermonitor/{vm_name}.{channel_num}' />
  <target type='virtio' name='virtio.serial.port.poweragent.{vm_channel_num}' />
  <address type='virtio-serial' controller='0' bus='0' port='{N}' />
</channel>
```

Where a single controller of type `virtio-serial` is created and up to 32 channels can be associated with a single controller and multiple controllers can be specified. The convention is to use the name of the VM in the host path `{vm_name}` and to increment `{channel_num}` for each channel, likewise the port value `{N}` must be incremented for each channel.

Each channel on the host will appear in `path`, the directory `/tmp/powermonitor/` must first be created and given `qemu` permissions

```
mkdir /tmp/powermonitor/
chown qemu:qemu /tmp/powermonitor
```

Note that files and directories within `/tmp` are generally removed upon rebooting the host and the above steps may need to be carried out after each reboot.

The serial device as it appears on a VM is configured with the *target* element attribute *name* and must be in the form of *virtio.serial.port.poweragent.{vm\_channel\_num}*, where *vm\_channel\_num* is typically the lcore channel to be used in DPDK VM applications.

Each channel on a VM will be present at */dev/virtio-ports/virtio.serial.port.poweragent.{vm\_channel\_num}*

## 32.4 Compiling and Running the Host Application

### 32.4.1 Compiling

1. export RTE\_SDK=/path/to/rte\_sdk
2. cd \${RTE\_SDK}/examples/vm\_power\_manager
3. make

### 32.4.2 Running

The application does not have any specific command line options other than *EAL*:

```
./build/vm_power_mgr [EAL options]
```

The application requires exactly two cores to run, one core is dedicated to the CLI, while the other is dedicated to the channel endpoint monitor, for example to run on cores 0 & 1 on a system with 4 memory channels:

```
./build/vm_power_mgr -c 0x3 -n 4
```

After successful initialization the user is presented with VM Power Manager CLI:

```
vm_power>
```

Virtual Machines can now be added to the VM Power Manager:

```
vm_power> add_vm {vm_name}
```

When a *{vm\_name}* is specified with the *add\_vm* command a lookup is performed with libvirt to ensure that the VM exists, *{vm\_name}* is used as a unique identifier to associate channels with a particular VM and for executing operations on a VM within the CLI. VMs do not have to be running in order to add them.

A number of commands can be issued via the CLI in relation to VMs:

Remove a Virtual Machine identified by *{vm\_name}* from the VM Power Manager.

```
rm_vm {vm_name}
```

Add communication channels for the specified VM, the virtio channels must be enabled in the VM configuration (qemu/libvirt) and the associated VM must be active. *{list}* is a comma-separated list of channel numbers to add, using the keyword 'all' will attempt to add all channels for the VM:

```
add_channels {vm_name} {list}|all
```

Enable or disable the communication channels in {list}(comma-separated) for the specified VM, alternatively list can be replaced with keyword 'all'. Disabled channels will still receive packets on the host, however the commands they specify will be ignored. Set status to 'enabled' to begin processing requests again:

```
set_channel_status {vm_name} {list}|all enabled|disabled
```

Print to the CLI the information on the specified VM, the information lists the number of vCPUS, the pinning to pCPU(s) as a bit mask, along with any communication channels associated with each VM, along with the status of each channel:

```
show_vm {vm_name}
```

Set the binding of Virtual CPU on VM with name {vm\_name} to the Physical CPU mask:

```
set_pcpu_mask {vm_name} {vcpu} {pcpu}
```

Set the binding of Virtual CPU on VM to the Physical CPU:

```
set_pcpu {vm_name} {vcpu} {pcpu}
```

Manual control and inspection can also be carried in relation CPU frequency scaling:

Get the current frequency for each core specified in the mask:

```
show_cpu_freq_mask {mask}
```

Set the current frequency for the cores specified in {core\_mask} by scaling each up/down/min/max:

```
set_cpu_freq {core_mask} up|down|min|max
```

Get the current frequency for the specified core:

```
show_cpu_freq {core_num}
```

Set the current frequency for the specified core by scaling up/down/min/max:

```
set_cpu_freq {core_num} up|down|min|max
```

## 32.5 Compiling and Running the Guest Applications

For compiling and running l3fwd-power, see Chapter 11 "L3 Forwarding with Power Management Application".

A guest CLI is also provided for validating the setup.

For both l3fwd-power and guest CLI, the channels for the VM must be monitored by the host application using the *add\_channels* command on the host.

### 32.5.1 Compiling

1. export RTE\_SDK=/path/to/rte\_sdk

2. cd \${RTE\_SDK}/examples/vm\_power\_manager/guest\_cli
3. make

### 32.5.2 Running

The application does not have any specific command line options other than *EAL*:

```
./build/vm_power_mgr [EAL options]
```

The application for example purposes uses a channel for each lcore enabled, for example to run on cores 0,1,2,3 on a system with 4 memory channels:

```
./build/guest_vm_power_mgr -c 0xf -n 4
```

After successful initialization the user is presented with VM Power Manager Guest CLI:

```
vm_power(guest)>
```

To change the frequency of a lcore, use the `set_cpu_freq` command. Where `{core_num}` is the lcore and channel to change frequency by scaling up/down/min/max.

```
set_cpu_freq {core_num} up|down|min|max
```

### Figures

Fig. 3.1 *Packet Flow*

Fig. 10.1 *Kernel NIC Application Packet Flow*

Fig. 11.1 *Performance Benchmark Setup (Basic Environment)*

Fig. 11.2 *Performance Benchmark Setup (Virtualized Environment)*

Fig. 12.1 *Performance Benchmark Setup (Basic Environment)*

Fig. 12.2 *Performance Benchmark Setup (Virtualized Environment)*

Fig. 15.1 *A typical IPv4 ACL rule*

Fig. 15.2 *Rules example*

Fig. 18.1 *Load Balancer Application Architecture*

Fig. 19.1 *Example Data Flow in a Symmetric Multi-process Application*

Fig. 19.2 *Example Data Flow in a Client-Server Symmetric Multi-process Application*

Fig. 19.3 *Master-slave Process Workflow*

Fig. 19.4 *Slave Process Recovery Process Flow*

Fig. 21.1 *QoS Scheduler Application Architecture*

Fig. 22.1 *Intel® QuickAssist Technology Application Block Diagram*

Fig. 23.1 *Pipeline Overview*

Fig. 23.2 *Ring-based Processing Pipeline Performance Setup*

Fig. 23.3 *Threads and Pipelines*

Fig. 26.1 *Packet Flow Through the VMDQ and DCB Sample Application*



Fig. 27.1 *System Architecture for Virtio-based Networking (virtio-net).*

Fig. 27.2 *Virtio with Linux*

Fig. 27.3 *Vhost-net Architectural Overview*

Fig. 27.4 *Packet Flow Through the vhost-net Sample Application*

Fig. 27.5 *Packet Flow on TX in DPDK-testpmd*

Fig. 30.1 *Test Pipeline Application*

Fig. 31.1 *Performance Benchmarking Setup (Basic Environment)*

Fig. 31.2 *Distributor Sample Application Layout*

Fig. 32.1 *Highlevel Solution*

Fig. 32.2 *VM request to scale frequency*

### **Tables**

Table 20.1 *Output Traffic Marking*

Table 21.1 *Entity Types*

Table 30.1 *Table Types*