



64-bit Intel® Xeon™ Processor MP with 1MB L2 Cache

Datasheet

March 2005



INFORMATION IN THIS DOCUMENT IS PROVIDED IN CONNECTION WITH INTEL® PRODUCTS. NO LICENSE, EXPRESS OR IMPLIED, BY ESTOPPEL OR OTHERWISE, TO ANY INTELLECTUAL PROPERTY RIGHTS IS GRANTED BY THIS DOCUMENT. EXCEPT AS PROVIDED IN INTEL'S TERMS AND CONDITIONS OF SALE FOR SUCH PRODUCTS, INTEL ASSUMES NO LIABILITY WHATSOEVER, AND INTEL DISCLAIMS ANY EXPRESS OR IMPLIED WARRANTY, RELATING TO SALE AND/OR USE OF INTEL PRODUCTS INCLUDING LIABILITY OR WARRANTIES RELATING TO FITNESS FOR A PARTICULAR PURPOSE, MERCHANTABILITY, OR INFRINGEMENT OF ANY PATENT, COPYRIGHT OR OTHER INTELLECTUAL PROPERTY RIGHT. Intel products are not intended for use in medical, life saving, or life sustaining applications.

Intel may make changes to specifications and product descriptions at any time, without notice.

Designers must not rely on the absence or characteristics of any features or instructions marked "reserved" or "undefined." Intel reserves these for future definition and shall have no responsibility whatsoever for conflicts or incompatibilities arising from future changes to them.

The 64-bit Intel® Xeon™ processor MP with 1MB L2 cache may contain design defects or errors known as errata which may cause the product to deviate from published specifications. Current characterized errata are available on request.

Contact your local Intel sales office or your distributor to obtain the latest specifications and before placing your product order.

I²C is a two-wire communications bus/protocol developed by Philips. SMBus is a subset of the I²C bus/protocol and was developed by Intel. Implementations of the I²C bus/protocol may require licenses from various entities, including Philips Electronics N.V. and North American Philips Corporation.

Intel, Pentium, Intel Xeon, Intel NetBurst, Intel SpeedStep, Intel Extended Memory 64 Technology and the Intel logo are trademarks or registered trademarks of Intel Corporation or its subsidiaries in the United States and other countries.

*Other names and brands may be claimed as the property of others.

Copyright © 2005, Intel Corporation.



Contents

1	Introduction.....	11
1.1	Terminology.....	12
1.2	Reference Documents.....	14
1.3	State of Data	14
2	Electrical Specifications.....	15
2.1	Front Side Bus Clock and Processor Clocking.....	15
2.1.1	Front Side Bus Clock Select (BSEL[1:0])	16
2.1.2	Phase Lock Loop (PLL) Power and Filter.....	16
2.2	Voltage Identification (VID).....	17
2.3	Reserved, Unused, and TESTHI Pins	19
2.4	Mixing Processors	20
2.5	Front Side Bus Signal Groups	20
2.6	GTL+ Asynchronous Signals and AGTL + Asynchronous Signals.....	22
2.7	Test Access Port (TAP) Connection.....	22
2.8	Absolute Maximum and Minimum Ratings	22
2.9	Processor DC Specifications	23
2.9.1	Flexible Motherboard (FMB) Guidelines	23
2.9.2	Vcc Overshoot Specification	27
2.10	AGTL+ Front Side Bus Specifications	31
2.11	Front Side Bus AC Specifications	32
2.12	Processor AC Timing Waveforms	36
3	Front Side Bus Signal Quality Specifications	45
3.1	Front Side Bus Signal Quality Specifications and Measurement Guidelines	45
3.1.1	Ringback Guidelines	45
3.1.2	Overshoot/Undershoot Guidelines	48
3.1.3	Overshoot/Undershoot Magnitude	48
3.1.4	Overshoot/Undershoot Pulse Duration.....	48
3.1.5	Activity Factor.....	48
3.1.6	Reading Overshoot/Undershoot Specification Tables.....	49
3.1.7	Determining if a System Meets the Overshoot/Undershoot Specifications	50
4	Mechanical Specifications	53
4.1	Package Mechanical Drawing	53
4.2	Processor Component Keepout Zones	56
4.3	Package Loading Specifications	56
4.4	Package Handling Guidelines	57
4.5	Package Insertion Specifications	57
4.6	Processor Mass Specifications	57
4.7	Processor Materials.....	57
4.8	Processor Markings.....	58
4.9	Processor Pin-Out Coordinates.....	59



5	Pin Listing.....	61
5.1	64-bit Intel® Xeon™ Processor MP with 1MB L2 Cache Pin Assignments.....	61
5.1.1	Pin Listing by Pin Name	61
5.1.2	Pin Listing by Pin Number	70
6	Signal Definitions	79
6.1	Signal Definitions	79
7	Thermal Specifications.....	87
7.1	Package Thermal Specifications.....	87
7.1.1	Thermal Specifications	87
7.1.2	Thermal Metrology	89
7.2	Processor Thermal Features.....	90
7.2.1	Thermal Monitor	90
7.2.2	Thermal Monitor 2	91
7.2.3	On-Demand Mode.....	92
7.2.4	PROCHOT# Signal Pin	93
7.2.5	FORCEPR# Signal Pin	93
7.2.6	THERMTRIP# Signal Pin	93
7.2.7	Tcontrol and Fan Speed Reduction	94
7.2.8	Thermal Diode.....	94
8	Features	95
8.1	Power-On Configuration Options	95
8.2	Clock Control and Low Power States.....	95
8.2.1	Normal State—State 1	95
8.2.2	HALT Power Down State—State 2	95
8.2.3	Stop-Grant State—State 3	96
8.2.4	HALT/Grant Snoop State—State 4	97
8.3	Enhanced Intel SpeedStep Technology	97
8.4	System Management Bus (SMBus) Interface	98
8.4.1	Processor Information ROM (PIROM).....	99
8.4.2	Scratch EEPROM	101
8.4.3	PIROM and Scratch EEPROM Supported SMBus Transactions.....	101
8.4.4	SMBus Thermal Sensor	101
8.4.5	Thermal Sensor Supported SMBus Transactions.....	102
8.4.6	SMBus Thermal Sensor Registers.....	104
8.4.7	SMBus Thermal Sensor Alert Interrupt	106
8.4.8	SMBus Device Addressing.....	106
8.4.9	Managing Data in the PIROM	108
9	Boxed Processor Specifications.....	113
9.1	Introduction	113
9.2	Mechanical Specifications.....	114
9.2.1	Boxed Processor Heatsink Dimensions	114
9.2.2	Boxed Processor Heatsink Weight.....	121
9.2.3	Boxed Processor Retention Mechanism and Heatsink Supports.....	121



9.3	Thermal Specifications	121
9.3.1	Boxed Processor Cooling Requirements	121
9.3.2	Boxed Processor Contents.....	122
10	Debug Tools Specifications.....	123
10.1	Logic Analyzer Interface (LAI).....	123
10.1.1	Mechanical Considerations	123
10.1.2	Electrical Considerations.....	123

Figures

2-1	Phase Lock Loop (PLL) Filter Requirements	17
2-2	64-bit Intel® Xeon™ Processor MP with 1MB L2 Cache Load Current vs. Time.....	25
2-3	VCC Static and Transient Tolerance.....	26
2-4	V _{CC} Overshoot Example Waveform.....	27
2-5	Electrical Test Circuit.....	36
2-6	TCK Clock Waveform.....	36
2-7	Differential Clock Waveform.....	37
2-8	Differential Clock Crosspoint Specification.....	37
2-9	Front Side Bus Common Clock Valid Delay Timing Waveform.....	38
2-10	Source Synchronous 2X (Address) Timing Waveform.....	38
2-11	Source Synchronous 4X (Data) Timing Waveform	39
2-12	TAP Valid Delay Timing Waveform	39
2-13	Test Reset (TRST#), Async GTL+ Input, and PROCHOT# Timing Waveform ...	40
2-14	THERMTRIP# Power Down Sequence.....	40
2-15	SMBus Timing Waveform.....	40
2-16	SMBus Valid Delay Timing Waveform	41
2-17	Voltage Sequence Timing Requirements.....	41
2-18	VIDPWRGD Timing Requirements	42
2-19	FERR#/PBE# Valid Delay Timing	42
2-20	VID Signal Group AC Specifications	43
2-21	VID Transition Times.....	43
3-1	Low-to-High Front Side Bus Receiver Ringback Tolerance	46
3-2	High-to-Low Front Side Bus Receiver Ringback Tolerance	46
3-3	Low-to-High Receiver Ringback Tolerance for PWRGOOD and TAP Signals ...	47
3-4	High-to-Low Receiver Ringback Tolerance for PWRGOOD and TAP Signals ...	47
3-5	Maximum Acceptable Overshoot/Undershoot Waveform	52
4-1	Processor Package Assembly Sketch.....	53
4-2	Processor Package Drawing (Sheet 1 of 2)	54
4-3	Processor Package Drawing (Sheet 2 of 2)	55
4-4	Processor Topside Markings.....	58
4-5	Processor Bottom-Side Markings.....	58
4-6	Processor Pin-Out Coordinates, Top View.....	59
7-1	64-bit Intel® Xeon™ Processor MP with 1MB L2 Cache Thermal Profile A	88
7-2	Case Temperature (TCASE) Measurement Location	90

7-3	Thermal Monitor 2 Frequency and Voltage Ordering	92
8-1	Stop Clock State Machine	96
8-2	Logical Schematic of SMBus Circuitry	98
9-1	Passive 64-bit Intel® Xeon™ Processor MP with 1MB L2 Cache Thermal Solution (3U and larger)	113
9-2	Top Side Board Keepout Zones (Part 1)	115
9-3	Top Side Board Keepout Zones (Part 2)	116
9-4	Bottom Side Board Keepout Zones	117
9-5	Board Mounting-Hole Keepout Zones	118
9-6	Thermal Solution Volumetric	119
9-7	Recommended Processor Layout and Pitch	120

Tables

1-1	Features of the 64-bit Intel® Xeon™ Processor MP with 1MB L2 Cache	12
2-1	Core Frequency to Front Side Bus Multiplier Configuration	15
2-2	BSEL[1:0] Frequency Table for BCLK[1:0]	16
2-3	Voltage Identification (VID) Definition	18
2-4	Front Side Bus Pin Groups	20
2-5	Signal Description Table	21
2-6	Signal Reference Voltages	21
2-7	Processor Absolute Maximum Ratings	23
2-8	Voltage and Current Specifications	24
2-9	VCC Static and Transient Tolerance	25
2-10	V _{CC} Overshoot Specifications	27
2-11	Front Side Bus Differential BCLK Specifications	28
2-12	BSEL[1:0], VID[5:0], and DC Specifications	28
2-13	VIDPWRGD DC Specifications	28
2-14	AGTL+ Signal Group DC Specifications	29
2-15	PWRGOOD Input and TAP Signal Group DC Specifications	29
2-16	GTL+ Asynchronous and AGTL+ Asynchronous Signal Group DC Specifications	30
2-17	SMBus Signal Group DC Specifications	30
2-18	AGTL+ Bus Voltage Definitions	31
2-19	Front Side Bus Differential Clock Specifications	32
2-20	Front Side Bus Common Clock AC Specifications	32
2-21	Front Side Bus Source Synchronous AC Specifications	33
2-22	Miscellaneous Signals AC Specifications	34
2-23	Front Side Bus AC Specifications (Reset Conditions)	34
2-24	TAP Signal Group AC Specifications	34
2-25	VIDPWRGD AC Specifications	35
2-26	VID Signal Group AC Timing Specifications	35
2-27	SMBus Signal Group AC Specifications	35
3-1	Ringback Specifications for AGTL+ and GTL+ Asynchronous Signal Groups	46
3-2	Ringback Specifications for PWRGOOD and TAP Signal Groups	46
3-3	Source Synchronous (667 MHz) GTL+ Signal Group Overshoot/Undershoot Tolerance	50



3-4	Source Synchronous (333 MHz) GTL+ Signal Group Overshoot/Undershoot Tolerance	51
3-5	Common Clock (166 MHz) GTL+ Signal Group Overshoot/Undershoot Tolerance	51
3-6	Asynchronous GTL+, PWRGOOD Input and TAP Signal Groups\ Overshoot/Undershoot Tolerance	51
4-1	Processor Loading Specifications	56
4-2	Package Handling Guidelines	57
4-3	Processor Materials.....	57
5-1	Pin Listing by Pin Name	61
5-2	Pin Listing by Pin Number	70
6-1	Signal Definitions.....	79
7-1	64-bit Intel® Xeon™ Processor MP with 1MB L2 Cache Thermal Specifications	88
7-2	64-bit Intel® Xeon™ Processor MP with 1MB L2 Cache Thermal Profile A	89
8-1	Power-On Configuration Option Pins	95
8-2	Processor Information ROM Format	99
8-3	Read Byte SMBus Packet	101
8-4	Write Byte SMBus Packet	101
8-5	Write Byte SMBus Packet	102
8-6	Read Byte SMBus Packet	102
8-7	Send Byte SMBus Packet	102
8-8	Receive Byte SMBus Packet.....	102
8-9	ARA SMBus Packet	103
8-10	SMBus Thermal Sensor Command Byte Bit Assignments.....	103
8-11	Thermal Reference Register Values	104
8-12	SMBus Thermal Sensor Status Register.....	105
8-13	SMBus Thermal Sensor Configuration Register	105
8-14	SMBus Thermal Sensor Conversion Rate Registers	106
8-15	Thermal Sensor SMBus Addressing	107
8-16	Memory Device SMBus Addressing.....	107
8-17	Offset 78h Definitions	111
8-18	128 Byte ROM Checksum Values.....	112

Revision History

Revision Number	Description	Date
001	<ul style="list-style-type: none"><li data-bbox="540 470 703 495">• Initial release.	March 2005



Product Features

- 64-bit Processor with Intel® Extended Memory 64 Technology (Intel® EM64T)¹
- Available at 2.83, 3.16, 3.33, and 3.66 GHz
- Multi-processing (4 sockets and above) server support
- Binary compatible with applications running on previous members of the Intel® microprocessor line
- Intel NetBurst® microarchitecture
- Hyper-Threading Technology
 - Hardware support for multi-threaded applications
- 667 MHz System bus with data-bus Error Correcting Code (ECC)
 - Dual independent bus architecture supports two processors per bus segment
 - Bandwidth up to 5.33 GB/second
 - Split Transaction Bus with Modified Enhanced Defer improves throughput
- Rapid Execution Engine: Arithmetic Logic Units (ALUs) run at twice the processor core frequency
- Hyper Pipelined Technology
- Level 1 Execution Trace Cache stores 12 K microops and removes decoder latency from main execution loops
 - Includes 16-KB Level 1 data cache
- 1MB Advanced Transfer L2 Cache (on-die, full speed Level 2 cache) with 8-way associativity and Error Correcting Code (ECC)
- Advance Dynamic Execution
 - Very deep out-of-order execution
 - Enhanced branch prediction
- Enables system support of up to 1024 GB of physical memory
- Streaming SIMD Extensions 2 (SSE2 and SSE3)
 - 144 new instructions for double-precision floating point operations, media/video streaming, and secure transactions
- Enhanced floating point and multimedia unit for enhanced video, audio, encryption, and 3D performance
- Power Management capabilities
 - Enhanced Intel Speed-Step® technology
 - System Management mode
 - Multiple low-power states
- Advanced System Management Features
 - System Management Bus
 - Processor Information ROM (PIROM)
 - OEM Scratch EEPROM
 - Thermal Monitor, Thermal Monitor 2 (TM2)
 - Machine Check Architecture (MCA)
- Execute Disable Bit² when used with operating systems helps protect against a certain class of malicious virus attacks.

NOTES:

1. 64-bit Intel® Xeon™ processors with Intel® EM64T requires a computer system with a processor, chipset, BIOS, OS, device drivers and applications enabled for Intel EM64T. Processor will not operate (including 32-bit operation) without an Intel EM64T-enabled BIOS. Performance will vary depending on your hardware and software configurations. Intel EM64T-enabled OS, BIOS, device drivers and applications may not be available. Check with your vendor for more information.
2. Execute Disable Bit requires operating system support. See <http://www.intel.com/business/bss/infrastructure/security/xdbit.htm> for more information on how to implement this feature.

The 64-bit Intel® Xeon™ processor MP with 1MB L2 cache is designed for high-performance multi-processor server applications for mid-tier enterprise serving and server consolidation. Based on the Intel NetBurst® microarchitecture and the new Hyper-Threading Technology, it is binary compatible with previous Intel Architecture processors. The addition of Intel EM64T provides 64-bit computing and 40-bit addressing provides up to 1 Tera-byte of direct memory addressability. The 64-bit Intel® Xeon™ processor MP with 1-MB L2 cache is scalable to four processors and beyond in a multiprocessor system providing exceptional performance for applications running on advanced operating systems such as Microsoft Windows* 2003 Server, and Linux* operating systems.

The 64-bit Intel® Xeon™ processor MP with 1MB L2 cache delivers compute power at unparalleled value and flexibility for internet infrastructure and departmental server applications, including application servers, databases, and business intelligence. The Intel NetBurst microarchitecture with Hyper-Threading technology and Intel EM64T deliver outstanding performance and headroom for peak internet server workloads, resulting in faster response times, support for more users, and improved scalability.

§





1 Introduction

The 64-bit Intel® Xeon™ processor MP with 1MB L2 cache is a 32-bit multiprocessor capable server processor based on improvements to the Intel NetBurst® microarchitecture. It maintains the tradition of compatibility with IA-32 software and includes features found in the Intel® Xeon™ processor such as hyper pipelined technology, a Rapid Execution Engine, and an Execution Trace Cache. Hyper pipelined technology includes a multi-stage pipeline, allowing the processor to reach much higher core frequencies. The 667 MHz front side bus (FSB) is a quad-pumped bus running off a 166 MHz system clock making 5.3 GB per second data transfer rates possible. The Execution Trace Cache is a level 1 (L1) cache that stores decoded micro-operations, which removes the decoder from the main execution path, thereby increasing performance. In addition, the 64-bit Intel® Xeon™ processor MP with 1MB L2 cache includes the Intel® Extended Memory 64 Technology (Intel® EM64T), providing additional addressing capability.

Enhanced thermal and power management capabilities are implemented including Thermal Monitor, Thermal Monitor 2 (TM2) and Enhanced Intel SpeedStep® technology. Thermal Monitor and TM2 provide efficient and effective cooling in high temperature situations. Enhanced Intel SpeedStep technology allows trade-offs to be made between performance and power consumption. This may lower average power consumption (in conjunction with OS support).

The 64-bit Intel® Xeon™ processor MP with 1MB L2 cache supports Hyper-Threading Technology (HT Technology). This feature allows a single, physical processor to function as two logical processors. While some execution resources such as caches, execution units, and buses are shared, each logical processor has its own architectural state with its own set of general-purpose registers, control registers to provide increased system responsiveness in multitasking environments, and headroom for next generation multi-threaded applications. More information on HT Technology can be found at <http://www.intel.com/technology/hyperthread>.

Support for Intel's Execute Disable Bit functionality has been added which can prevent certain classes of malicious “buffer overflow” attacks when combined with a supporting operating system. Execute Disable Bit allows the processor to classify areas in memory by where application code can execute and where it cannot. When a malicious worm attempts to insert code in the buffer, the processor disables code execution, preventing damage or worm propagation.

Other features within the Intel NetBurst microarchitecture include Advanced Dynamic Execution, Advanced Transfer Cache, enhanced floating point and multi-media unit, Streaming SIMD Extensions 2 (SSE2) and Streaming SIMD Extensions 3 (SSE3). Advanced Dynamic Execution improves speculative execution and branch prediction internal to the processor. The Advanced Transfer Cache is a 1 MB, on-die, level 2 (L2) cache with increased bandwidth. The floating point and multi-media units include 128-bit wide registers and a separate register for data movement. Streaming SIMD2 (SSE2) instructions provide highly efficient double-precision floating point, SIMD integer, and memory management operations. In addition, (SSE3) instructions have been added to further extend the capabilities of Intel processor technology. Other processor enhancements include core frequency improvements and microarchitectural improvements.

The 64-bit Intel® Xeon™ processor MP with 1MB L2 cache is intended for high performance multi-processor server systems with support for up to two processors on a 667 MHz FSB. All versions of the 64-bit Intel® Xeon™ processor MP with 1MB L2 cache will include manageability

features. Components of the manageability features include an OEM writable EEPROM and Processor Information ROM which are accessed through an SMBus interface and contain information relevant to the particular processor and system in which it is installed.

Table 1-1. Features of the 64-bit Intel® Xeon™ Processor MP with 1MB L2 Cache

	# of Supported Sockets per FSB	L2 Advanced Transfer Cache	Front Side Bus Frequency	Package
Processor	1 - 2	1 MB	667 MHz	604-pin FC-mPGA4

The 64-bit Intel® Xeon™ processor MP with 1MB L2 cache supports Intel EM64T as an enhancement to Intel's IA-32 architecture. This enhancement allows the processor to execute operating systems and applications written to take advantage of the 64-bit extension technology. Further details on Intel EM64T and its programming model can be found in the *64-bit Extension Technology Software Developer's Guide* at <http://developer.intel.com/technology/64bitextensions/>.

The 64-bit Intel® Xeon™ processor MP with 1MB L2 cache is packaged in a 604-pin Flip-Chip Micro Pin Grid Array (FC-mPGA4) package and utilizes a surface-mount Zero Insertion Force (ZIF) mPGA604 socket.

The 64-bit Intel® Xeon™ processor MP with 1MB L2 cache uses a scalable system bus protocol referred to as the “front side bus” in this document. The FSB utilizes a split-transaction, deferred reply protocol. The FSB uses Source-Synchronous Transfer (SST) of address and data to improve performance. The processor transfers data four times per bus clock (4X data transfer rate). Along with the 4X data bus, the address bus can deliver addresses two times per bus clock and is referred to as a ‘double-clocked’, ‘double-pumped’, or the 2X address bus. In addition, the Request Phase completes in one clock cycle. Working together, the 4X data bus and 2X address bus provide a data bus bandwidth of up to 5.3 GB per second. Finally, the FSB is also used to deliver interrupts.

1.1 Terminology

A ‘#’ symbol after a signal name refers to an active low signal, indicating that a signal is in the asserted state when driven to a low level. For example, when RESET# is low (i.e. when RESET# is asserted), a reset has been requested. Conversely, when NMI is high (i.e. when NMI is asserted), a nonmaskable interrupt request has occurred. In the case of signals where the name does not imply an active state but describes part of a binary sequence (such as *address* or *data*), the ‘#’ symbol implies that the signal is inverted. For example, D[3:0] = ‘HLHL’ refers to a hex ‘A’, and D[3:0]# = ‘LHLH’ also refers to a hex ‘A’ (H= High logic level, L= Low logic level).

“Front side bus” refers to the interface between the processor, system core logic (i.e. the chipset components), and other bus agents. The FSB supports multiprocessing and cache coherency. For this document, “front side bus” is used as the generic term for the “64-bit Intel® Xeon™ processor MP system bus”.

Commonly used terms are explained here for clarification:

- **64-bit Intel® Xeon™ processor MP with 1MB L2 cache** — Intel 32-bit microprocessor intended for multi processor servers and workstations. The 64-bit Intel® Xeon™ processor MP with 1MB L2 cache is based on Intel’s 90 nanometer process and will include core frequency improvements, a large cache array, microarchitectural improvements and additional instructions. The 64-bit Intel® Xeon™ processor MP with 1MB L2 cache will use the mPGA604 socket. For this document, “processor” is used as the generic term for the “64-bit Intel® Xeon™ processor MP with 1MB L2 cache.”

- **FC-mPGA4** — The 64-bit Intel® Xeon™ processor MP with 1MB L2 cache is available in a Flip-Chip Micro Pin Grid Array 4 package, consisting of a processor core mounted on a pinned substrate with an integrated heat spreader (IHS). This packaging technology employs a 1.27 mm [0.05 in] pitch for the substrate pins.
- **Front Side Bus (FSB)** — The electrical interface that connects the processor to the chipset. Also referred to as the processor system bus or the system bus. All memory and I/O transactions as well as interrupt messages pass between the processor and chipset over the FSB.
- **Functional Operation** — Refers to the normal operating conditions in which all processor specifications, including DC, AC, system bus, signal quality, mechanical, and thermal, are satisfied.
- **Enhanced Intel SpeedStep Technology** — Enhanced Intel SpeedStep technology is the next generation implementation of Geyserville technology which extends power management capabilities of servers and workstations.
- **Integrated Heat Spreader (IHS)** — A component of the processor package used to enhance the thermal performance of the package. Component thermal solutions interface with the processor at the IHS surface.
- **mPGA604** — The 64-bit Intel® Xeon™ processor MP with 1MB L2 cache mates with the system board through this surface mount, 604-pin, zero insertion force (ZIF) socket.
- **OEM** — Original Equipment Manufacturer.
- **Processor core** — The processor's execution engine. All AC timing and signal integrity specifications are to the pads of the processor core.
- **Processor Information ROM (PIROM)** — A memory device located on the processor and accessible via the System Management Bus (SMBus) which contains information regarding the processor's features. This device is shared with the Scratch EEPROM, is programmed during manufacturing, and is write-protected.
- **Scratch EEPROM** (Electrically Erasable, Programmable Read-Only Memory) — A memory device located on the processor and addressable via the SMBus which can be used by the OEM to store information useful for system management.
- **SMBus** — System Management Bus. A two-wire interface through which simple system and power management related devices can communicate with the rest of the system. It is based on the principals of the operation of the I²C two-wire serial bus from Phillips Semiconductor.

Note: I²C* is a two-wire communications bus/protocol developed by Philips. SMBus is a subset of the I²C bus/protocol and was developed by Intel. Implementations of the I²C bus/protocol or the SMBus bus/protocol may require licenses from various entities, including Philips Electronics N.V. and North American Philips Corporation.

- **Storage Conditions** — Refers to a non-operational state. The processor may be installed in a platform, in a tray, or loose. Processors may be sealed in packaging or exposed to free air. Under these conditions, processor pins should not be connected to any supply voltages, have any I/Os biased, or receive any clocks.
- **Symmetric Agent** — A symmetric agent is a processor which shares the same I/O subsystem and memory array, and runs the same operating system as another processor in a system. Systems using symmetric agents are known as Symmetric MultiProcessing (SMP) systems. The 64-bit Intel® Xeon™ processor MP should only be used in SMP systems which have two or fewer symmetric agents per FSB.

1.2 Reference Documents

Material and concepts available in the following documents may be beneficial when reading this document:

Document	Intel Document Number
<i>Intel® Extended Memory 64 Technology Software Developer's Manual, Volume 1</i>	300834
<i>Intel® Extended Memory 64 Technology Software Developer's Manual, Volume 2</i>	300835
<i>mPGA604 Socket Design Guidelines</i>	254232
<i>AP-485 Intel® Processor Identification and CPUID Instruction</i>	241618
<i>IA-32 Intel® Architecture Optimization Reference Manual</i>	248966
<i>IA-32 Intel® Architecture Software Developer's Manual, Volume 1: Basic Architecture</i>	253665
<i>IA-32 Intel® Architecture Software Developer's Manual, Volume 2A: Instruction Set Reference, A-M</i>	253666
<i>IA-32 Intel® Architecture Software Developer's Manual, Volume 2B: Instruction Set Reference, N-Z</i>	253667
<i>IA-32 Intel® Architecture Software Developer's Manual, Volume 3: System Programming Guide</i>	253668
<i>ITP700 Debug Port Design Guide</i>	249679
<i>64-bit Intel® Xeon™ Processor MP with 1MB L2 Cache Specification Update</i>	306752
<i>64-bit Intel® Xeon™ Processor MP with 1MB L2 Cache Core Boundary Scan Descriptive Language (BSDL) Model (V1.0) and Cell Descriptor File (V1.0)</i>	1
<i>64-bit Intel® Xeon™ Processor MP with 1MB L2 Cache Thermal Models</i>	1
<i>64-bit Intel® Xeon™ Processor MP with 1MB L2 Cache Mechanical Models (IGES)</i>	1
<i>64-bit Intel® Xeon™ Processor MP with 1MB L2 Cache Mechanical Models (ProE*)</i>	1
<i>64-bit Intel® Xeon™ Processor MP with 1MB L2 Cache Thermal / Mechanical Design Guide</i>	306750
<i>Voltage Regulator Module (VRM) and Enterprise Voltage Regulator-Down (EVRD) 10.1 Design Guidelines</i>	302732
<i>Voltage Regulator Module (VRM) and Enterprise Voltage Regulator-Down (EVRD) 10.2 Design Guidelines</i>	306760

NOTE:

1. See the *Intel® Xeon™ Processor Message of the Week* for latest document version and order numbers. Contact your Intel representative to receive the latest revisions of these documents.

1.3 State of Data

The data contained within this document is subject to change. It is the most accurate information available by the publication date of this document.

§



2 Electrical Specifications

2.1 Front Side Bus Clock and Processor Clocking

BCLK[1:0] directly controls the FSB interface speed as well as the core frequency of the processor. As in previous processor generations, the 64-bit Intel® Xeon™ processor MP with 1MB L2 cache core frequency is a multiple of the BCLK[1:0] frequency. The processor bus ratio multiplier will be set during manufacturing. The default setting will be the maximum speed for the processor.

The BCLK[1:0] inputs directly control the operating speed for the FSB interface. The processor core frequency is configured during reset by using values stored internally during manufacturing. The stored value sets the highest bus fraction at which the particular processor can operate. If lower speeds are desired, the appropriate ratio can be configured by setting bits [15:8] of the IA32_FLEX_BRVID_SEL_MSR.

Clock multiplying within the processor is provided by the internal phase locked loop (PLL), which requires a constant frequency BCLK[1:0] input, with exceptions for spread spectrum clocking. Processor DC and AC specifications for the BCLK[1:0] inputs are provided in [Table 2-11](#) and [Table 2-19](#), respectively. These specifications must be met while also meeting signal integrity requirements as outlined in [Section 3](#). The 64-bit Intel® Xeon™ processor MP with 1MB L2 cache utilizes differential clocks. Details regarding BCLK[1:0] driver specifications are provided in the *CK409 Clock Synthesizer/Driver Design Guidelines* or *CK409B Clock Synthesizer/Driver Design Guidelines*. [Table 2-1](#) contains core frequency to FSB multipliers and their corresponding core frequencies.

Table 2-1. Core Frequency to Front Side Bus Multiplier Configuration

Core Frequency to Front Side Bus Multiplier	Core Frequency with 166 MHz Front Side Bus Clock	Notes
1/17	2.83 GHz	1
1/18	3 GHz	1
1/19	3.16 GHz	1
1/20	3.33 GHz	1
1/21	3.50 GHz	1
1/22	3.66 GHz	1

NOTES:

1. Individual processors operate only at or below the frequency marked on the package.

2.1.1 Front Side Bus Clock Select (BSEL[1:0])

The BSEL[1:0] signals are used to select the frequency of the processor input clock (BCLK[1:0]). [Table 2-2](#) defines the possible combinations of the signals and the frequency associated with each combination. The required frequency is determined by the processor, chipset, and clock synthesizer. All processors must operate at the same FSB frequency.

The 64-bit Intel® Xeon™ processor MP with 1MB L2 cache operates at a 667 MHz FSB frequency (selected by a 166 MHz BCLK[1:0] frequency).

For more information about these pins, refer to [Section 6.1](#) and the appropriate platform design guide.

Table 2-2. BSEL[1:0] Frequency Table for BCLK[1:0]

BSEL1	BSEL0	Function
0	0	RESERVED
0	1	RESERVED
1	0	RESERVED
1	1	166 MHz

2.1.2 Phase Lock Loop (PLL) Power and Filter

V_{CCA} , $V_{CCIOPLL}$ are power sources required by the PLL clock generators on the 64-bit Intel® Xeon™ processor MP with 1MB L2 cache. These are analog PLLs and they require low noise power supplies for minimum jitter. These supplies must be low pass filtered from V_{TT} .

The AC low-pass requirements, with input at V_{TT} , are as follows:

- < 0.2 dB gain in pass band
- < 0.5 dB attenuation in pass band < 1 Hz
- > 34 dB attenuation from 1 MHz to 66 MHz
- > 28 dB attenuation from 66 MHz to core frequency

The filter requirements are illustrated in [Figure 2-1](#). For recommendations on implementing the filter, refer to the appropriate platform design guide.

Figure 2-1. Phase Lock Loop (PLL) Filter Requirements

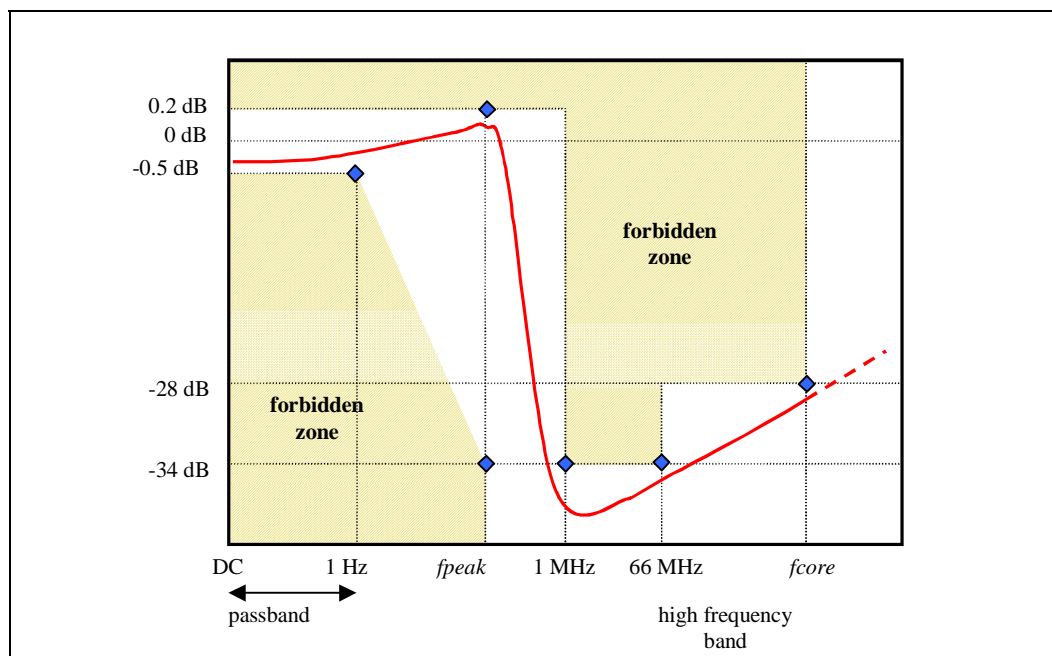
NOTES:

1. Diagram not to scale.
2. No specification for frequencies beyond f_{core} (core frequency).
3. f_{peak} , if existent, should be less than 0.05 MHz.

2.2 Voltage Identification (VID)

The VID[5:0] pins supply the encodings that determine the voltage to be supplied by the V_{CC} (the core voltage for the 64-bit Intel® Xeon™ processor MP with 1MB L2 cache) voltage regulator. The VID specification for the 64-bit Intel® Xeon™ processor MP with 1MB L2 cache is defined by the *Voltage Regulator Module (VRM) and Enterprise Voltage Regulator-Down (EVRD) 10.2 Design Guidelines*. The voltage set by the VID pins is the maximum V_{CC} voltage allowed by the processor. A minimum V_{CC} voltage is provided in Table 2-7 and changes with frequency. This allows processors running at a higher frequency to have a relaxed minimum V_{CC} voltage specification. The specifications have been set such that one voltage regulator can work with all supported frequencies.

Individual processor VID values may be calibrated during manufacturing such that two devices at the same core speed may have different default VID settings. Furthermore, any 64-bit Intel® Xeon™ processor MP with 1MB L2 cache, even those on the same processor FSB, can drive different VID settings during normal operation.

The 64-bit Intel® Xeon™ processor MP with 1MB L2 cache uses six voltage identification pins (VID[5:0]) to support automatic selection of power supply voltages. Table 2-3 specifies the voltage level corresponding to the state of VID[5:0]. A '1' in this table refers to a high voltage level and a '0' refers to a low voltage level. If the processor socket is empty (i.e. when the voltage regulator sees VID[5:0] = 111111 or VID[5:0] = 011111), or the voltage regulation circuit cannot supply the voltage that is requested, the processor's voltage regulator must disable itself. See the *Voltage Regulator Module (VRM) and Enterprise Voltage Regulator-Down (EVRD) 10.2 Design Guidelines* for more details.

The 64-bit Intel® Xeon™ processor MP with 1MB L2 cache provides the ability to operate while transitioning to an adjacent VID and its associated processor core voltage (V_{CC}). This will represent a DC shift in the load line. It should be noted that a low-to-high or high-to-low voltage state change may result in as many VID transitions as necessary to reach the target core voltage. Transitions above the specified VID are not permitted. Table 2-7 includes VID step sizes and DC shift ranges.

The VRM or VRD utilized must be capable of regulating its output to the value defined by the new VID. DC specifications for VID transitions are included in Table 2-8 and Table 2-9, while AC specifications are included in Table 2-26. Please refer to the *Voltage Regulator Module (VRM) and Enterprise Voltage Regulator-Down (EVRD) 10.2 Design Guidelines* for more details.

Power source characteristics must be guaranteed to be stable whenever the supply to the voltage regulator is stable.

Further details and specifications will be included in future revisions of this document.

Table 2-3. Voltage Identification (VID) Definition (Sheet 1 of 2)

VID5	VID4	VID3	VID2	VID1	VID0	VID (V)		VID5	VID4	VID3	VID2	VID1	VID0	VID (V)
0	0	1	0	1	0	0.8375		0	1	1	0	1	0	1.2125
1	0	1	0	0	1	0.8500		1	1	1	0	0	1	1.2250
0	0	1	0	0	1	0.8625		0	1	1	0	0	1	1.2375
1	0	1	0	0	0	0.8750		1	1	1	0	0	0	1.2500
0	0	1	0	0	0	0.8875		0	1	1	0	0	0	1.2625
1	0	0	1	1	1	0.9000		1	1	0	1	1	1	1.2750
0	0	0	1	1	1	0.9125		0	1	0	1	1	1	1.2875
1	0	0	1	1	0	0.9250		1	1	0	1	1	0	1.3000
0	0	0	1	1	0	0.9375		0	1	0	1	1	0	1.3125
1	0	0	1	0	1	0.9500		1	1	0	1	0	1	1.3250
0	0	0	1	0	1	0.9625		0	1	0	1	0	1	1.3375
1	0	0	1	0	0	0.9750		1	1	0	1	0	0	1.3500
0	0	0	1	0	0	0.9875		0	1	0	1	0	0	1.3625
1	0	0	0	1	1	1.0000		1	1	0	0	1	1	1.3750
0	0	0	0	1	1	1.0125		0	1	0	0	1	1	1.3875
1	0	0	0	1	0	1.0250		1	1	0	0	1	0	1.4000
0	0	0	0	1	0	1.0375		0	1	0	0	1	0	1.4125
1	0	0	0	0	1	1.0500		1	1	0	0	0	1	1.4250
0	0	0	0	0	1	1.0625		0	1	0	0	0	1	1.4375
1	0	0	0	0	0	1.0750		1	1	0	0	0	0	1.4500
0	0	0	0	0	0	1.0875		0	1	0	0	0	0	1.4625
1	1	1	1	1	1	VRM off		1	0	1	1	1	1	1.4750
0	1	1	1	1	1	VRM off		0	0	1	1	1	1	1.4875
1	1	1	1	1	0	1.1000		1	0	1	1	1	0	1.5000
0	1	1	1	1	0	1.1125		0	0	1	1	1	0	1.5125

Table 2-3. Voltage Identification (VID) Definition (Sheet 2 of 2)

VID5	VID4	VID3	VID2	VID1	VID0	VID (V)	VID5	VID4	VID3	VID2	VID1	VID0	VID (V)
1	1	1	1	0	1	1.1250	1	0	1	1	0	1	1.5250
0	1	1	1	0	1	1.1375	0	0	1	1	0	1	1.5375
1	1	1	1	0	0	1.1500	1	0	1	1	0	0	1.5500
0	1	1	1	0	0	1.1625	0	0	1	1	0	0	1.5625
1	1	1	0	1	1	1.1750	1	0	1	0	1	1	1.5750
0	1	1	0	1	1	1.1875	0	0	1	0	1	1	1.5875
1	1	1	0	1	0	1.2000	1	0	1	0	1	0	1.6000

2.3 Reserved, Unused, and TESTHI Pins

All RESERVED pins must be left unconnected. Connection of these pins to V_{CC} , V_{SS} , or to any other signal (including each other) can result in component malfunction or incompatibility with future processors. See Section 5 for a pin listing for the processor and the location of all RESERVED pins.

For reliable operation, always terminate unused inputs or bidirectional signals to their respective deasserted states. On-die termination has been included on the 64-bit Intel® Xeon™ processor MP with 1MB L2 cache to allow signals to be terminated within the processor silicon. Most unused AGTL+ inputs may be left as no-connects since AGTL+ termination is provided on the processor silicon. See Table 2-5 for details on AGTL+ signals that do not include on-die termination. Unused active-high inputs should be connected through a resistor to ground (V_{SS}). Unused outputs may be left unconnected. However, this may interfere with some TAP functions, complicate debug probing, and prevent boundary scan testing. A resistor must be used when tying bidirectional signals to power or ground. When tying any signal to power or ground, a resistor will also allow for system testability. For unused AGTL+ input or I/O signals, use pull-up resistors of the same value as the on-die termination resistors (R_{TT}). See Table 2-15.

TAP, Asynchronous GTL+ inputs, and Asynchronous GTL+ outputs do not include on-die termination. Inputs and utilized outputs must be terminated on the baseboard. Unused outputs may be terminated on the baseboard or left unconnected. Note that leaving unused outputs unterminated may interfere with some TAP functions, complicate debug probing, and prevent boundary scan testing. Signal termination for these signal types is discussed in the appropriate platform design guidelines.

Don't Care pins are pins on the processor package that are not connected to the processor die. These pins can be connected on the motherboard in any way necessary for compatible motherboard designs to support other processor versions.

The TESTHI pins should be tied to V_{TT} using a matched resistor, where a matched resistor has a resistance value within $\pm 20\%$ of the impedance of the board transmission line traces. For example, if the trace impedance is 50Ω , then a value between 40Ω and 60Ω is required.

The TESTHI pins may use individual pull-up resistors or be grouped together as detailed below. Please note that utilization of boundary scan test will not be functional if pins are connected together. A matched resistor should be used for each group:

- TESTHI[3:0]
- TESTHI[6:5]
- TESTHI4 – cannot be grouped with other TESTHI signals

2.4 Mixing Processors

Intel supports and validates multi-processor configurations in which all processors operate with the same FSB frequency and internal cache sizes. Intel does not support or validate operation of processors with different cache sizes. Mixing different processor steppings but the same model (as per the CPUID instruction) is supported.

2.5 Front Side Bus Signal Groups

The FSB signals are grouped by buffer type as listed in Table 2-4. The buffer type indicates which AC and DC specifications apply to the signals. AGTL+ input signals have differential input buffers that use GTLREF as a reference level. In this document, the term “AGTL+ Input” refers to the AGTL+ input group as well as the AGTL+ I/O group when receiving. Similarly, “AGTL+ Output” refers to the AGTL+ output group as well as the AGTL+ I/O group when driving.

Implementing a source synchronous data bus requires specifying two sets of timing parameters. One set is for common clock signals which are dependent upon the rising edge of BCLK0 (ADS#, HIT#, HITM#, etc.). The second set is for the source synchronous signals that are relative to their respective strobe lines (data and address) as well as the rising edge of BCLK0. Asynchronous signals are present (A20M#, IGNNE#, etc.) and can become active at any time during the clock cycle. Table 2-4 identifies signals as common clock, source synchronous, and asynchronous.

Table 2-4. Front Side Bus Pin Groups (Sheet 1 of 2)

Signal Group	Type	Signals ¹														
AGTL+ Common Clock Input	Synchronous to BCLK[1:0]	BPRI#, BR[3:1]#, DEFER#, RESET#, RS[2:0]#, RSP#, TRDY#														
AGTL+ Common Clock I/O	Synchronous to BCLK[1:0]	ADS#, AP[1:0]#, BINIT#, BNR#, BPM[5:0]#, BR0#, DBSY#, DP[3:0]#, DRDY#, HIT#, HITM#, LOCK#, MCERR#														
AGTL+ Source Synchronous I/O	Synchronous to associated strobe	<table border="1"> <thead> <tr> <th>Signals</th> <th>Associated Strobe</th> </tr> </thead> <tbody> <tr> <td>REQ[4:0]#, A[37:36,16:3]#</td> <td>ADSTB0#</td> </tr> <tr> <td>A[39:38,35:17]#</td> <td>ADSTB1#</td> </tr> <tr> <td>D[15:0]#, DBI0#</td> <td>DSTBP0#, DSTBN0#</td> </tr> <tr> <td>D[31:16]#, DBI1#</td> <td>DSTBP1#, DSTBN1#</td> </tr> <tr> <td>D[47:32]#, DBI2#</td> <td>DSTBP2#, DSTBN2#</td> </tr> <tr> <td>D[63:48]#, DBI3#</td> <td>DSTBP3#, DSTBN3#</td> </tr> </tbody> </table>	Signals	Associated Strobe	REQ[4:0]#, A[37:36,16:3]#	ADSTB0#	A[39:38,35:17]#	ADSTB1#	D[15:0]#, DBI0#	DSTBP0#, DSTBN0#	D[31:16]#, DBI1#	DSTBP1#, DSTBN1#	D[47:32]#, DBI2#	DSTBP2#, DSTBN2#	D[63:48]#, DBI3#	DSTBP3#, DSTBN3#
		Signals	Associated Strobe													
		REQ[4:0]#, A[37:36,16:3]#	ADSTB0#													
		A[39:38,35:17]#	ADSTB1#													
		D[15:0]#, DBI0#	DSTBP0#, DSTBN0#													
		D[31:16]#, DBI1#	DSTBP1#, DSTBN1#													
		D[47:32]#, DBI2#	DSTBP2#, DSTBN2#													
D[63:48]#, DBI3#	DSTBP3#, DSTBN3#															
AGTL+ Strobe Input/Output	Synchronous to BCLK[1:0]	ADSTB[1:0]#, DSTBP[3:0]#, DSTBN[3:0]#														
AGTL+ Asynchronous Output	Asynchronous	FERR#/PBE#, IERR#, PROCHOT#,														
GTL+ Asynchronous Input	Asynchronous	A20M#, FORCEPR#, IGNNE#, INIT#, LINT0/INTR, LINT1/NMI, SMI#, STPCLK#														
GTL+ Asynchronous Output	Asynchronous	THERMTRIP#														
TAP Input	Synchronous to TCK	TCK, TDI, TMS														
TAP Input	Asynchronous	TRST#														
TAP Output	Synchronous to TCK	TDO														
Front Side Bus Clock Input	Clock	BCLK[1:0]														

Table 2-4. Front Side Bus Pin Groups (Sheet 2 of 2)

Signal Group	Type	Signals ¹
SMBus	Synchronous to SM_CLK	SM_ALERT#, SM_CLK, SM_DAT, SM_EP_A[2:0], SM_TS_A[1:0], SM_WP
Power/Other	Power/Other	BOOT_SELECT, BSEL[1:0], COMP0, TESTHI[6:0], GTLREF[3:0], ODTEN, PWRGOOD, RESERVED, SKTOCC#, SLEW_CTRL, SM_VCC, TEST_BUS, V _{CC} , V _{CCA} , V _{CCIOPLL} , V _{CCSENSE} , VID[5:0], VIDPWRGD, V _{SS} , V _{SSA} , V _{SSSENSE} , V _{TT} , VTEN, PROCTYPE

NOTES:

1. Refer to [Section 6.1](#) for signal descriptions.

Table 2-5. Signal Description Table

Signals with R _{TT} ¹
A[39:3]#, ADS#, ADSTB[1:0]#, AP[1:0]#, BINIT#, BNR#, BOOT_SELECT ² , BPRI#, D[63:0]#, DBI[3:0]#, DBSY#, DEFER#, DP[3:0]#, DRDY#, DSTBN[3:0]#, DSTBP[3:0]#, FORCEPR#, HIT#, HITM#, LOCK#, MCERR#, REQ[4:0]#, RS[2:0]#, SLEW_CTRL, TEST_BUS, RSP#, TRDY#
Signals with R _L
BINIT#, BNR#, HIT#, HITM#, MCERR#

NOTES:

1. Signals not included in the "Signals with R_{TT}" list require termination on the baseboard. Please refer to [Table 2-4](#) for the signal type and [Table 2-12](#) to [Table 2-17](#) for the corresponding DC specifications.
2. The BOOT_SELECT pin is not terminated with R_{TT}. It has a 500-5000 Ω internal pullup.

The ODTEN signals enables or disables R_{TT}. Those signals affected by ODTEN still present R_{TT} termination to the signal's pin when the processor is placed in tri-state mode.

Furthermore, the following signals are not affected when the processor is placed in tri-state mode: BSEL[1:0], SKTOCC#, SM_ALERT#, SM_CLK, SM_DAT, SM_EP_A[2:0], SM_TS_A[1:0], SM_WP, TEST_BUS, TESTHI[6:0], VID[5:0], TDO and VTEN.

Table 2-6. Signal Reference Voltages

GTLREF	V _{TT} / 2
A20M#, A[39:3]#, ADS#, ADSTB[1:0]#, AP[1:0]#, BINIT#, BNR#, BPM[5:0]#, BPRI#, BR[3:0]#, D[63:0]#, DBI[3:0]#, DBSY#, DEFER#, DP[3:0]#, DRDY#, DSTBN[3:0]#, DSTBP[3:0]#, FORCEPR#, HIT#, HITM#, IGNNE#, INIT#, LINT0/INTR, LINT1/NMI, LOCK#, MCERR#, ODTEN, REQ[4:0]#, RESET#, RS[2:0]#, RSP#, SMI#, STPCLK#, TRDY#	BOOT_SELECT, PWRGOOD ¹ , TCK ¹ , TDI ¹ , TMS ¹ , TRST# ¹ , VIDPWRGD

NOTES:

1. These signals also have hysteresis added to the reference voltage. See [Table 2-15](#) for more information.

2.6 GTL+ Asynchronous Signals and AGTL+ Asynchronous Signals

The 64-bit Intel® Xeon™ processor MP with 1MB L2 cache does not utilize CMOS voltage levels on any signals that connect to the processor silicon. As a result, input signals such as A20M#, FORCEPR#, IGNNE#, INIT#, LINT0/INTR, LINT1/NMI, SMI#, SLP#, and STPCLK# utilize GTL input buffers. Legacy output THERMTRIP# utilizes a GTL+ output buffers. All of these Asynchronous GTL+ signals follow the same DC requirements as GTL+ signals, however the outputs are not driven high (during the logical 0-to-1 transition) by the processor. FERR#/PBE#, IERR#, and IGNNE# have now been defined as AGTL+ asynchronous signals as they include an active p-MOS device. GTL+ asynchronous and AGTL+ asynchronous signals do not have setup or hold time specifications in relation to BCLK[1:0]. However, all of the GTL+ asynchronous and AGTL+ asynchronous signals are required to be asserted/deasserted for at least six BCLKs in order for the processor to recognize them. See [Table 2-16](#) and [Table 2-22](#) for the DC and AC specifications for the asynchronous GTL+ signal groups.

2.7 Test Access Port (TAP) Connection

Due to the voltage levels supported by other components in the TAP logic, Intel recommends that the 64-bit Intel® Xeon™ processor MP with 1MB L2 cache be first in the TAP chain, followed by any other components within the system. Use of a translation buffer to connect to the rest of the chain is recommended unless one of the other components is capable of accepting an input of the appropriate voltage. Similar considerations must be made for TCK, TMS, TRST#, TDI, and TDO. Two copies of each signal may be required, each driving a different voltage level.

2.8 Absolute Maximum and Minimum Ratings

[Table 2-7](#) specifies absolute maximum and minimum ratings. Within functional operation limits, functionality and long-term reliability can be expected.

At conditions outside functional operation condition limits, but within absolute maximum and minimum ratings, neither functionality nor long-term reliability can be expected. If a device is returned to conditions within functional operation limits after having been subjected to conditions outside these limits, but within the absolute maximum and minimum ratings, the device may be functional, but with its lifetime degraded depending on exposure to conditions exceeding the functional operation condition limits.

At conditions exceeding absolute maximum and minimum ratings, neither functionality nor long-term reliability can be expected. Moreover, if a device is subjected to these conditions for any length of time then, when returned to conditions within the functional operating condition limits, it will either not function, or its reliability will be severely degraded.

Although the processor contains protective circuitry to resist damage from static electric discharge, precautions should always be taken to avoid high static voltages or electric fields.

Table 2-7. Processor Absolute Maximum Ratings

Symbol	Parameter	Min	Max	Unit	Notes ^{1, 2}
V _{CC}	Processor core supply voltage with respect to V _{SS}	-0.3	1.55	V	
V _{TT}	Front side bus termination voltage with respect to V _{SS}	-0.3	1.55	V	
T _{CASE}	Processor case temperature	See Section 7	See Section 7	°C	
T _{STORAGE}	Processor storage temperature	-40	85	°C	3, 4

NOTES:

1. For functional operation, all processor electrical, signal quality, mechanical, and thermal specifications must be satisfied.
2. Overshoot and undershoot voltage guidelines for input, output, and I/O signals are outlined in Section 3. Excessive overshoot or undershoot on any signal will likely result in permanent damage to the processor.
3. Storage temperature is applicable to storage conditions only. In this scenario, the processor must not receive a clock, and no pins can be connected to a voltage bias. Storage within these limits will not affect the long-term reliability of the device. For functional operation, please refer to the processor case temperature specifications.
4. This rating applies to the processor and does not include any packaging or trays.

2.9 Processor DC Specifications

The following notes apply:

- The processor DC specifications in this section are defined at the processor core silicon and not at the package pins unless noted otherwise.
- The notes associated with each parameter are part of the specification for that parameter.
- Unless otherwise noted, all specifications in the tables apply to all frequencies and cache sizes.
- Unless otherwise noted, all the specifications in the tables are based on estimates and simulations. These specifications will be updated with characterized data from silicon measurements at a later date.

See Section 6 for the pin signal definitions. Most of the signals on the processor FSB are in the AGTL+ signal group. The DC specifications for these signals are listed in Table 2-14.

Table 2-8 through Table 2-18 list the DC specifications for the 64-bit Intel® Xeon™ processor MP with 1MB L2 cache and are valid only while meeting specifications for case temperature, clock frequency, and input voltages.

2.9.1 Flexible Motherboard (FMB) Guidelines

The FMB guidelines are estimates of the maximum values that the 64-bit Intel® Xeon™ processor MP with 1MB L2 cache will reach over the product lifetime. The values are only estimates as actual specifications for future processors may differ. The 64-bit Intel® Xeon™ processor MP with 1MB L2 cache may or may not have specifications equal to the FMB value in the foreseeable future. System designers should meet the FMB values to ensure that their systems will be compatible with future releases of the 64-bit Intel® Xeon™ processor MP with 1MB L2 cache.

Table 2-8. Voltage and Current Specifications

Symbol	Parameter	Min	Typ	Max	Unit	Notes ¹
VID range	VID range for 64-bit Intel® Xeon™ processor MP	1.2875		1.4000	V	2, 3
V _{CC}	V _{CC} for 64-bit Intel Xeon processor MP	See Table 2-9 and Figure 2-3		VID - I _{CC} (max) * 1.25 mΩ	V	3, 4, 5, 6, 7
VID Transition	VID step size during a transition			±12.5	mV	8
	Total allowable DC load line shift from VID steps			450	mV	9
V _{TT}	Front side bus termination voltage (DC specification)	1.176	1.20	1.224	V	10
	Front side bus termination voltage (AC & DC specification)	1.140	1.20	1.260	V	10, 11
SM_VCC	SMBus supply voltage	3.135	3.300	3.465	V	12
I _{CC}	I _{CC} for 64-bit Intel Xeon processor MP with multiple VIDs 3.16 - FMB GHz			120	A	6, 7, 13
I _{TT}	Front Side Bus end-agent V _{TT} current			4.8	A	14
I _{TT}	Front Side Bus mid-agent V _{TT} current			1.5	A	12
I _{SM_VCC}	I _{CC} for SvMBus supply		100	122.5	mA	11
I _{CC_VCCA}	I _{CC} for PLL power pins			60	mA	15
I _{CC_VCCIOPLL}	I _{CC} for PLL power pins			60	mA	15
I _{CC_GTLREF}	I _{CC} for GTLREF pins			200	μA	16
I _{SGNT}	I _{CC} Stop Grant for 64-bit Intel Xeon processor MP 3.16 GHz - FMB			50	A	7, 17
I _{TCC}	I _{CC} TCC Active			I _{CC}	A	18
I _{CC_TDC}	I _{CC} for 64-bit Intel Xeon processor MP Thermal Design Current 3.16 - FMB GHz			105	A	7, 13, 19

NOTES:

- Unless otherwise noted, all specifications in this table apply to all processors. These specifications are based on silicon characterization, however they may be updated as further data becomes available. Listed frequencies are not necessarily committed production frequencies.
- Individual processor VID values may be calibrated during manufacturing such that two devices at the same speed may have different VID settings.
- These voltages are targets only. A variable voltage source should exist on systems in the event that a different voltage is required. See [Section 2.2](#) for more information.
- The voltage specification requirements are measured across vias on the platform for the VCCSENSE and VSSSENSE pins close to the socket with a 100 MHz bandwidth oscilloscope, 1.5 pF maximum probe capacitance, and 1 MΩ minimum impedance. The maximum length of ground wire on the probe should be less than 5 mm. Ensure external noise from the system is not coupled in the scope probe.
- Refer to [Table 2-9](#) and corresponding [Figure 2-3](#). The processor should not be subjected to any static V_{CC} level that exceeds the V_{CC_MAX} associated with any particular current. Failure to adhere to this specification can shorten processor lifetime.
- Minimum V_{CC} and maximum I_{CC} are specified at the maximum processor case temperature (T_{CASE}) shown in [Table 7-1](#). I_{CC_MAX} is specified at the relative V_{CC_MAX} point on the V_{CC} load line. The processor is capable of drawing I_{CC_MAX} for up to 10 ms. Refer to [Figure 2-2](#) for further details on the average processor current draw over various time durations.
- FMB is the flexible motherboard guideline. These guidelines are for estimation purposes only. See [Section 2.9.1](#) for further details on FMB guidelines.
- This specification represents the V_{CC} reduction due to each VID transition. See [Section 2.2](#). AC timing requirements will be included in future revisions of this document.
- This specification refers to the potential total reduction of the load line due to VID transitions below the specified VID.
- V_{TT} must be provided via a separate voltage source and must not be connected to V_{CC}. This specification is measured at the pin.
- Baseboard bandwidth is limited to 20 MHz.
- This specification refers to a single processor with R_{TT} disabled. Please note the end agent and middle agent may not require I_{TT}(max) simultaneously. Details will be provided in future revisions of this document.
- This specification refers to platforms implementing a power delivery system that complies with VR 10.2 guidelines. Please see the *Voltage Regulator Module (VRM) and Enterprise Voltage-Regulator-Down (EVRD) 10.2 Design Guidelines* for further details.
- This specification refers to a single processor with R_{TT} enabled. Please note the end agent and middle agent may not require I_{TT}(max) simultaneously. This parameter is based on design characterization and not tested.

15. These specifications apply to the PLL power pins VCCA, VCCIOPLL, and VSSA. See Section 2.1.2 for details. These parameters are based on design characterization and are not tested.
16. This specification represents a total current for all GTLREF pins.
17. The current specified is also for HALT State.
18. The maximum instantaneous current the processor will draw while the thermal control circuit is active as indicated by the assertion of the PROCHOT# signal is the maximum I_{CC} for the processor.
19. I_{CC_TDC} (Thermal Design Current) is the sustained (DC equivalent) current that the processor is capable of drawing indefinitely and should be used for the voltage regulator temperature assessment. The voltage regulator is responsible for monitoring its temperature and asserting the necessary signal to inform the processor of a thermal excursion. Please see the applicable design guidelines for further details. The processor is capable of drawing I_{CC_TDC} indefinitely. Refer to Figure 2-2 for further details on the average processor current draw over various time durations. This parameter is based on design characterization and is not tested.

Figure 2-2. 64-bit Intel® Xeon™ Processor MP with 1MB L2 Cache Load Current vs. Time

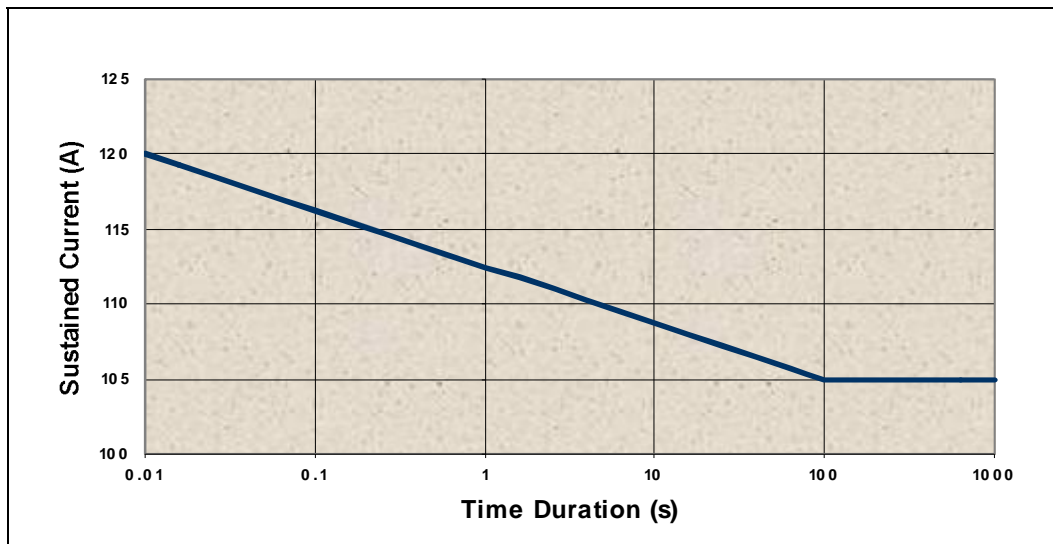

NOTES:

1. Processor or voltage regulator thermal protection circuitry should not trip for load currents greater than I_{CC_TDC} .
2. Not 100% tested. Specified by design characterization.

Table 2-9. V_{CC} Static and Transient Tolerance (Sheet 1 of 2)

I_{CC}	Voltage Deviation from VID Setting (V) ^{1,2}		
	V_{CC_Max}	V_{CC_Typ}	V_{CC_Min}
0	VID - 0.000	VID - 0.020	VID - 0.040
5	VID - 0.006	VID - 0.026	VID - 0.046
10	VID - 0.013	VID - 0.033	VID - 0.052
15	VID - 0.019	VID - 0.039	VID - 0.059
20	VID - 0.025	VID - 0.045	VID - 0.065
25	VID - 0.031	VID - 0.051	VID - 0.071
30	VID - 0.038	VID - 0.058	VID - 0.077
35	VID - 0.044	VID - 0.064	VID - 0.084
40	VID - 0.050	VID - 0.070	VID - 0.090
45	VID - 0.056	VID - 0.076	VID - 0.096
50	VID - 0.063	VID - 0.083	VID - 0.103
55	VID - 0.069	VID - 0.089	VID - 0.109
60	VID - 0.075	VID - 0.095	VID - 0.115

Table 2-9. V_{CC} Static and Transient Tolerance (Sheet 2 of 2)

I _{CC}	Voltage Deviation from VID Setting (V) ^{1,2}		
	V _{CC_Max}	V _{CC_Typ}	V _{CC_Min}
65	VID - 0.081	VID - 0.101	VID - 0.121
70	VID - 0.087	VID - 0.108	VID - 0.128
75	VID - 0.094	VID - 0.114	VID - 0.134
80	VID - 0.100	VID - 0.120	VID - 0.140
85	VID - 0.106	VID - 0.126	VID - 0.146
90	VID - 0.113	VID - 0.133	VID - 0.153
95	VID - 0.119	VID - 0.139	VID - 0.159
100	VID - 0.125	VID - 0.145	VID - 0.165
105	VID - 0.131	VID - 0.151	VID - 0.171
110	VID - 0.138	VID - 0.158	VID - 0.178
115	VID - 0.144	VID - 0.164	VID - 0.184
120	VID - 0.150	VID - 0.170	VID - 0.190

NOTES:

1. The V_{CC_MIN} and V_{CC_MAX} loadlines represent static and transient limits.
2. This table is intended to aid in reading discrete points on [Figure 2-3](#).

Figure 2-3. V_{CC} Static and Transient Tolerance

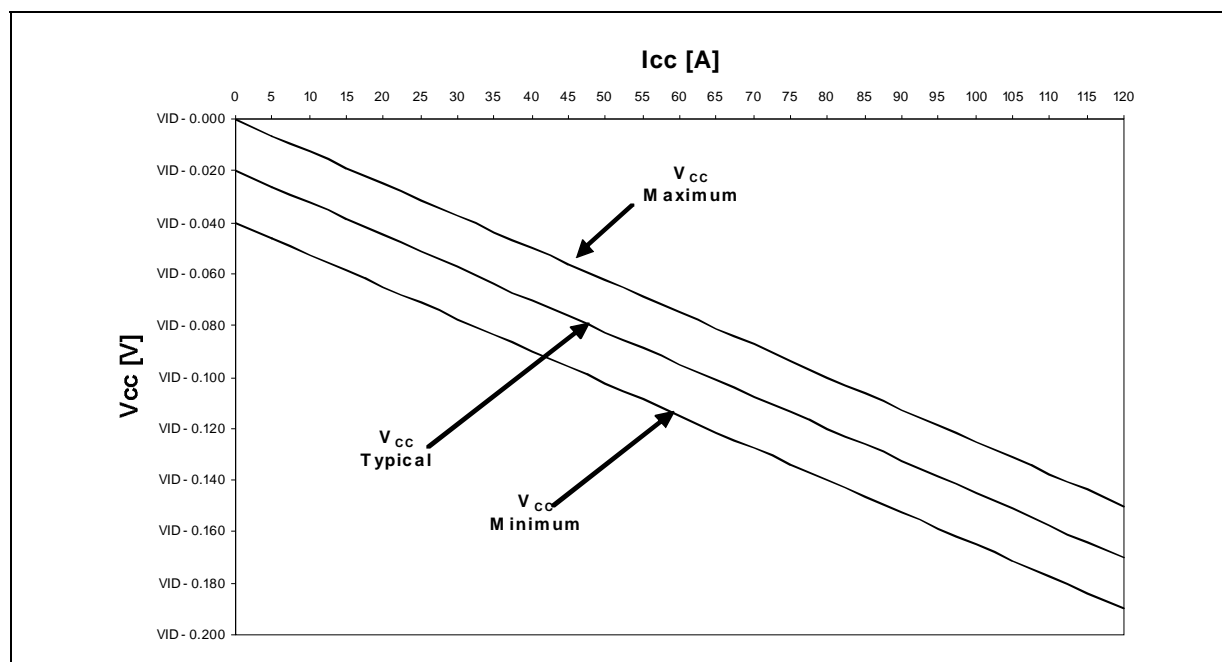

NOTES:

1. The V_{CC_MIN} and V_{CC_MAX} loadlines represent static and transient limits.
2. The V_{CC_MIN} and V_{CC_MAX} loadlines are plots of the discrete point found in [Table 2-9](#).
3. Refer to [Table 2-8](#) for processor VID information.
4. The loadlines specify voltage limits at the die measured at the VCCSENSE and VSSSENSE pins. Voltage regulation feedback for voltage regulator circuits must be taken from processor V_{CC} and V_{SS} pins. Refer to the *Voltage Regulator Module (VRM) and Enterprise Voltage Regulator Down (EVRD) 10.2 Design Guidelines* for socket loadline guidelines and VR implementation.

2.9.2 V_{CC} Overshoot Specification

The 64-bit Intel® Xeon™ processor MP with 1MB L2 cache can tolerate short transient overshoot events where V_{CC} exceeds the VID voltage when transitioning from a high-to-low current load condition. This overshoot cannot exceed VID + V_{OS_MAX}. (V_{OS_MAX} is the maximum allowable overshoot above VID). These specifications apply to the processor die voltage as measured across the VCCSENSE and VSSSENSE pins.

Table 2-10. V_{CC} Overshoot Specifications

Symbol	Parameter	Min	Max	Units	Figure	Notes
V _{OS_MAX}	Magnitude of V _{CC} overshoot above VID		0.050	V	2-4	
T _{OS_MAX}	Time duration of V _{CC} overshoot above VID		25	μs	2-4	

Figure 2-4. V_{CC} Overshoot Example Waveform

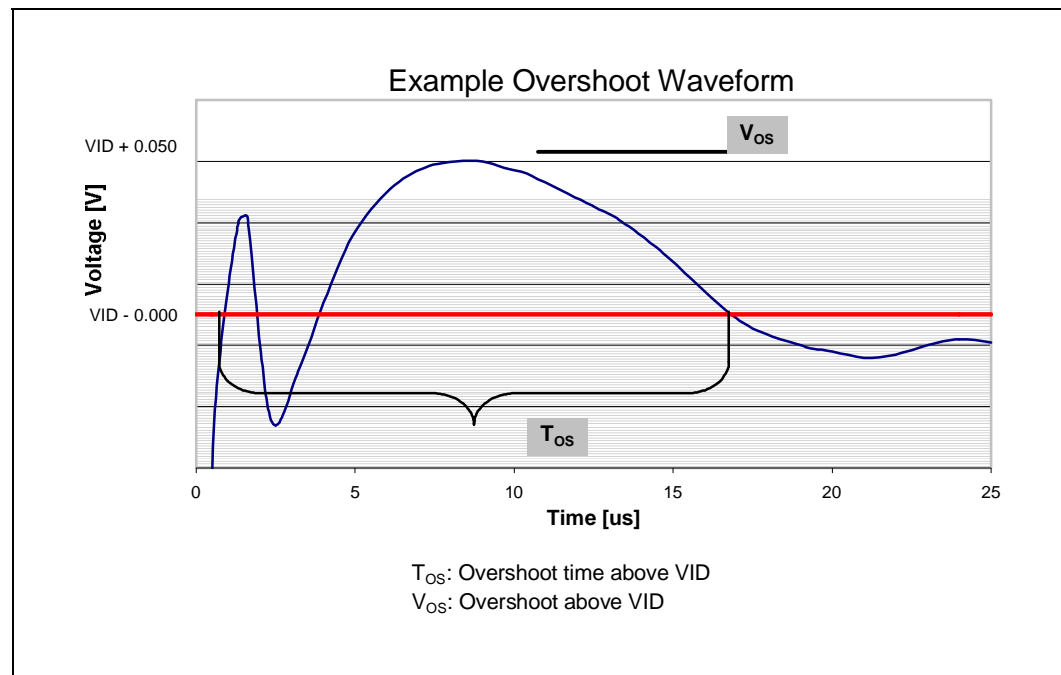

NOTES:

1. V_{OS} is measured overshoot voltage.
2. T_{OS} is measured time duration above VID.

Table 2-11. Front Side Bus Differential BCLK Specifications

Symbol	Parameter	Min	Typ	Max	Unit	Figure	Notes
V _L	Input Low Voltage	-0.150	0.000	N/A	V	2-7	
V _H	Input High Voltage	0.660	0.700	0.850	V	2-7	
V _{CROSS(abs)}	Absolute Crossing Point	0.250	N/A	0.550	V	2-7, 2-8	1, 2
V _{CROSS(rel)}	Relative Crossing Point	$0.250 + 0.5^*$ (V _{Havg} - 0.700)	N/A	$0.550 + 0.5^*$ (V _{Havg} - 0.700)	V	2-7, 2-8	3, 2, 4
Δ V _{CROSS}	Range of Crossing Point	N/A	N/A	0.140	V	2-7, 2-8	
V _{OV}	Overshoot	N/A	N/A	V _H + 0.300	V	2-7	5
V _{US}	Undershoot	-0.300	N/A	N/A	V	2-7	6
V _{RBM}	Ringback Margin	0.200	N/A	N/A	V	2-7	7
V _{TM}	Threshold Margin	V _{CROSS} -0.100		V _{CROSS} +0.100	V	2-7	8

NOTES:

- Crossing voltage is defined as the instantaneous voltage value when the rising edge of BCLK0 is equal to the falling edge of BCLK1.
- The crossing point must meet the absolute and relative crossing point specifications simultaneously.
- V_{Havg} is the statistical average of the V_H measured by the oscilloscope.
- V_{Havg} can be measured directly using "Vtop" on Agilent scopes and "High" on Tektronix scopes.
- Overshoot is defined as the absolute value of the maximum voltage.
- Undershoot is defined as the absolute value of the minimum voltage.
- Ringback Margin is defined as the absolute voltage difference between the maximum Rising Edge Ringback and the maximum Falling Edge Ringback.
- Threshold Region is defined as a region entered around the crossing point voltage in which the differential receiver switches. It includes input threshold hysteresis.

Table 2-12. BSEL[1:0], VID[5:0], and DC Specifications

Symbol	Parameter	Max	Unit	Notes
R _{ON}	Buffer On Resistance	60	Ω	1
I _{OL}	Max Pin Current	8	mA	
I _{LO}	Output Leakage Current	200	μA	2
V _{TOL}	Voltage Tolerance	3.3 + 5%	V	3

NOTES:

- These parameters are not tested and are based on design simulations.
- Leakage to V_{SS} with pin held at 2.5V.
- Represents the maximum allowable termination voltage.

Table 2-13. VIDPWRGD DC Specifications

Symbol	Parameter	Min	Max	Unit	Figure	Notes
V _{IL}	Input Low Voltage	0.0	0.30	V	2-18	
V _{IH}	Input High Voltage	0.90	V _{TT}	V	2-18	

Table 2-14. AGTL+ Signal Group DC Specifications

Symbol	Parameter	Min	Max	Unit	Notes
V _{IL}	Input Low Voltage	0.0	GTLREF – (0.10 * V _{TT})	V	2, 3
V _{IH}	Input High Voltage	GTLREF +(0.10 * V _{TT})	V _{TT}	V	2, 4, 5
V _{OH}	Output High Voltage	0.90 * V _{TT}	V _{TT}	V	2, 5
I _{OL}	Output Low Current	N/A	$\frac{V_{TT}}{(0.50 * R_{tt_min} + R_{ON_min} R_L)}$	mA	2, 6
I _{LI}	Input Leakage Current	N/A	±200	µA	7, 8
I _{LO}	Output Leakage Current	N/A	±200	µA	7, 8
R _{ON}	Buffer On Resistance	7	11	Ω	

NOTES:

1. Unless otherwise noted, all specifications in this table apply to all processor frequencies.
2. The V_{TT} represented in these specifications refers to instantaneous V_{TT}.
3. V_{IL} is defined as the voltage range at a receiving agent that will be interpreted as a logical low value.
4. V_{IH} is defined as the voltage range at a receiving agent that will be interpreted as a logical high value.
5. V_{IH} and V_{OH} may experience excursions above V_{TT}. However, input signal drivers must comply with the signal quality specifications in [Section 3](#).
6. Refer to [Table 2-5](#) to determine which signals include additional on-die termination resistance (R_L). Please refer to [Table 2-18](#) for R_L and R_{TT} specifications.
7. Leakage to V_{SS} with pin held at V_{TT}.
8. Leakage to V_{TT} with pin held at 300 mV.

Table 2-15. PWRGOOD Input and TAP Signal Group DC Specifications

Symbol	Parameter	Min	Max	Unit	Notes 1, 2, 3
V _{HYS}	Input Hysteresis	200	350	mV	4
V _{t+}	Input Low to High Threshold Voltage	0.5 * (V _{TT} + V _{HYS_MIN})	0.5 * (V _{TT} + V _{HYS_MAX})	V	5
V _{t-}	Input High to Low Threshold Voltage	0.5 * (V _{TT} – V _{HYS_MAX})	0.5 * (V _{TT} – V _{HYS_MIN})	V	4
V _{OH}	Output High Voltage	N/A	V _{TT}	V	4
I _{OL}	Output Low Current		45	mA	6
I _{LI}	Input Leakage Current	N/A	±200	µA	
I _{LO}	Output Leakage Current	N/A	±200	µA	
R _{ON}	Buffer On Resistance	7	11	Ω	

NOTES:

1. Unless otherwise noted, all specifications in this table apply to all processor frequencies.
2. All outputs are open drain.
3. PWRGOOD input and the TAP signal group must meet system signal quality specification in [Section 3](#).
4. V_{HYS} represents the amount of hysteresis, nominally centered about 0.5 * V_{TT} for all PWRGOOD and TAP inputs.
5. The V_{TT} represented in these specifications refers to instantaneous V_{TT}.
6. The maximum output current is based on maximum current handling capability of the buffer and is not specified into the test load.

Table 2-16. GTL+ Asynchronous and AGTL+ Asynchronous Signal Group DC Specifications

Symbol	Parameter	Min	Max	Unit	Notes ¹
V _{IL}	Input Low Voltage	0.0	GTLREF – (0.10 * V _{TT})	V	2, 3
V _{IH}	Input High Voltage	GTLREF +(0.10 * V _{TT})	V _{TT}	V	2, 4, 5
V _{OH}	Output High Voltage	0.90 * V _{TT}	V _{TT}	V	2, 5
I _{OL}	Output Low Current	N/A	$\frac{V_{TT}}{(0.50 * R_{TT_MIN} + [R_{ON_MIN} R_L])}$	mA	2, 6
I _{LI}	Input Leakage Current	N/A	±200	µA	7, 8
I _{LO}	Output Leakage Current	N/A	±200	µA	7, 8
R _{on}	Buffer On Resistance	7	11	W	

NOTES:

1. Unless otherwise noted, all specifications in this table apply to all processor frequencies.
2. The V_{TT} represented in these specifications refers to instantaneous V_{TT}.
3. V_{IL} is defined as the voltage range at a receiving agent that will be interpreted as a logical low value.
4. V_{IH} is defined as the voltage range at a receiving agent that will be interpreted as a logical high value.
5. V_{IH} and V_{OH} may experience excursions above V_{TT}. However, input signal drivers must comply with the signal quality specifications in Section 3.
6. Refer to Table 2-5 to determine which signals include additional on-die termination resistance (R_L). Please refer to Table 2-18 for R_L and R_{TT} specifications.
7. Leakage to V_{SS} with pin held at V_{TT}.
8. Leakage to V_{TT} with pin held at 300 mV.

Table 2-17. SMBus Signal Group DC Specifications

Symbol	Parameter	Min	Max	Unit	Notes 1, 2
V _{IL}	Input Low Voltage	-0.30	0.30 * SM_VCC	V	
V _{IH}	Input High Voltage	0.70 * SM_VCC	3.465	V	
V _{OL}	Output Low Voltage	0	0.400	V	
I _{OL}	Output Low Current	N/A	3.0	mA	
I _{LI}	Input Leakage Current	N/A	± 10	µA	
I _{LO}	Output Leakage Current	N/A	± 10	µA	
C _{SMB}	SMBus Pin Capacitance		15.0	pF	3

NOTES:

1. These parameters are based on design characterization and are not tested.
2. All DC specifications for the SMBus signal group are measured at the processor pins.
3. Platform designers may need this value to calculate the maximum loading of the SMBus and to determine maximum rise and fall times for SMBus signals.

2.10 AGTL+ Front Side Bus Specifications

Routing topology recommendations are in the appropriate platform design guide. Termination resistors are not required for most AGTL+ signals because they are integrated into the processor silicon.

Valid high and low levels are determined by the input buffers which compare a signal's voltage with a reference voltage called GTLREF.

Table 2-18 lists the GTLREF specifications. GTLREF should be generated on the system board using high-precision voltage divider circuits. For more details on platform design, see the appropriate platform design guide.

Table 2-18. AGTL+ Bus Voltage Definitions

Symbol	Parameter	Min	Typ	Max	Units	Notes ¹
GTLREF	Bus Reference Voltage	$0.98 * (0.63 * V_{TT})$	$0.63 * V_{TT}$	$1.02 * (0.63 * V_{TT})$	V	1, 2, 3, 4, 6
R_{TT}	Termination Resistance (pull up)	45	50	55	Ω	5
R_L	Termination Resistance (pull down)	400	500	600	Ω	7, 8
COMP[0]	COMP Resistance	49.4	49.9	50.4	Ω	9
SLEW_CTRL	SLEW_CTRL Voltage End Agent	$0.63 * V_{TT}$		V_{TT}	V	
SLEW_CTRL	SLEW_CTRL Voltage Mid Agent	V_{SS}		$0.63 * V_{TT}$	V	

NOTES:

1. Unless otherwise noted, all specifications in this table apply to all processor frequencies.
2. The tolerances for this specification have been stated generically to enable system designer to calculate the minimum values across the range of V_{TT} .
3. GTLREF is generated from V_{TT} on the baseboard by a voltage divider of 1% resistors. The minimum and maximum specifications account for this resistor tolerance. Refer to the appropriate platform design guidelines for implementation details.
4. The V_{TT} in these specifications refers to instantaneous V_{TT} .
5. R_{TT} is the on-die termination resistance measured at $V_{TT}/2$ of the AGTL+ output driver. Refer to the processor I/O buffer models for I/V characteristics.
6. These signals include an on-package pull up resistor to V_{TT} .
7. These parameters are based on design characterization and are not tested.
8. R_L is on-die termination resistance for improved noise margin and signal integrity. Refer to Table 2-5 for signals that include R_L . R_L is not configurable and is always enabled.
9. COMP resistors are provided on the baseboard with 1% resistors. See the appropriate platform design guidelines for implementation details. COMP value may vary with chipset.

2.11 Front Side Bus AC Specifications

The processor FSB timings specified in this section are defined at the processor core silicon and are thus not measurable at the processor pins.

See Section 6 for the 64-bit Intel® Xeon™ processor MP with 1MB L2 cache pin signal definitions.

Table 2-19 through Table 2-26 list the AC specifications associated with the processor FSB.

All AGTL+ timings are referenced to GTLREF for both ‘0’ and ‘1’ logic levels unless otherwise specified.

The timings specified in this section should be used in conjunction with the signal integrity models provided by Intel. These signal integrity models, which include package information, are available for the 64-bit Intel® Xeon™ processor MP with 1MB L2 cache. AGTL+ layout guidelines are also available in the appropriate platform design guide.

Table 2-19. Front Side Bus Differential Clock Specifications

T# Parameter	Min	Nom	Max	Unit	Figure	Notes ¹
FSB Clock Frequency	165.78		166.72	MHz		
T1: BCLK[1:0] Period	5.9982		6.0320	ns	2-7	2
T2: BCLK[1:0] Period Stability			175	ps		3, 4
T3: BCLK[1:0] Rise Time	175		700	ps		5
T4: BCLK[1:0] Fall Time	175		700	ps		5

NOTES:

- Unless otherwise noted, all specifications in this table apply to all processor core frequencies based on a 166 MHz BCLK[1:0].
- The period specified here is the average period. A given period may vary from this specification as governed by the period stability specification (T2). Min period specification is based on -300 PPM deviation from a 6 ns period. Max period specification is based on the summation of +300 PPM deviation from a 6 ns period and a +0.5% maximum variance due to spread spectrum clocking.
- For the clock jitter specification, refer to the appropriate platform design guide as well as the applicable clock driver design guidelines.
- In this context, period stability is defined as the worst case timing difference between successive crossover voltages. In other words, the largest absolute difference between adjacent clock periods must be less than the period stability.
- Rise and fall times are measured single-ended between 245 mV and 455 mV of the clock swing.

Table 2-20. Front Side Bus Common Clock AC Specifications

T# Parameter	Min	Max	Unit	Figure	Notes 1, 2
T10: Common Clock Output Valid Delay	-0.25	1.00	ns	2-9	3
T11: Common Clock Input Setup Time	0.70	N/A	ns	2-9	4
T12: Common Clock Input Hold Time	0.41	N/A	ns	2-9	4
T13: RESET# Pulse Width	1.00	10.00	ms	2-17	5, 6, 7

NOTES:

- These parameters are based on design characterization and are not tested.
- All common clock AC timings for AGTL+ signals are referenced to the Crossing Voltage (VCROSS) of the BCLK[1:0] at rising edge of BCLK0. All common clock AGTL+ signal timings are referenced at GTLREF at the processor core.
- Valid delay timings for these signals are specified into the test circuit described in Figure 2-5 and with GTLREF at $0.63 V_{TT} \pm 2\%$.
- Specification is for a minimum swing defined between V_{IL_MAX} to V_{IH_MIN} . This assumes an edge rate of 0.9 V/ns to 1.2 V/ns.
- RESET# can be asserted (active) asynchronously, but must be deasserted synchronously.
- This should be measured after V_{TT} and BCLK[1:0] become stable.
- Maximum specification applies only while PWRGOOD is asserted.

Table 2-21. Front Side Bus Source Synchronous AC Specifications

T# Parameter	Min	Typ	Max	Unit	Figure	Notes 1, 2, 3
T20: Source Sync. Output Valid Delay (first data/address only)	-0.200		1.150	ns	2-10, 2-11	4
T21: T _{VBD} Source Sync. Data Output Valid Before Data Strobe	0.350			ns	2-11	4, 5
T22: T _{VAD} Source Sync. Data Output Valid After Data Strobe	0.350			ns	2-11	4, 6
T23: T _{VBA} Source Sync. Address Output Valid Before Address Strobe	0.800			ns	2-10	4, 5
T24: T _{VAA} Source Sync. Address Output Valid After Address Strobe	0.800			ns	2-10	4, 6
T25: T _{SUSS} Source Sync. Input Setup Time to Strobe	0.125			ns	2-10, 2-11	7
T26: T _{HSS} Source Sync. Input Hold Time to Strobe	0.125			ns	2-10,	7
T27: T _{SUCC} Source Sync. Input Setup Time to BCLK[1:0]	0.750			ns	2-10, 2-11	8
T28: T _{FASS} First Address Strobe to Second Address Strobe		1/2		BCLKs	2-10	9
T29: T _{FDSS} : First Data Strobe to Subsequent Strobes		n/4		BCLKs	2-11	10,11
T30: Data Strobe 'n' (DSTBn#) Output Valid Delay	4.13		5.38	ns	2-11	12
T31: Address Strobe Output Valid Delay	1.00		2.25	ns	2-10	

NOTES:

- Not 100% tested. These parameters are based on design characterization.
- All source synchronous AC timings are referenced to their associated strobe at GTLREF. Source synchronous data signals are referenced to the falling edge of their associated data strobe. Source synchronous address signals are referenced to the rising and falling edge of their associated address strobe. All source synchronous AGTL+ signal timings are referenced at GTLREF at the processor core.
- Unless otherwise noted, these specifications apply to both data and address timings.
- Valid delay timings for these signals are specified into the test circuit described in Figure 2-5 and with GTLREF at $2/3 V_{TT} \pm 2\%$.
- This specification represents the minimum time the data or address will be valid before its strobe. Refer to the appropriate platform design guide for more information on the definitions and use of these specifications.
- This specification represents the minimum time the data or address will be valid after its strobe. Refer to the appropriate platform design guide for more information on the definitions and use of these specifications.
- Specification is for a minimum swing defined between V_{IL_MAX} to V_{IH_MIN} . AC timings are specified as $GTLREF \pm (0.06 * V_{TT})$. This assumes an edge rate of 0.9 V/ns to 1.2 V/ns.
- All source synchronous signals must meet the specified setup time to BCLK as well as the setup time to each respective strobe.
- The rising edge of ADSTB# must come approximately 1/2 BCLK period after the falling edge of ADSTB#.
- For this timing parameter, n = 1, 2, and 3 for the second, third, and last data strobes respectively.
- The second data strobe (falling edge of DSTBn#) must come approximately 1/4 BCLK period after the first falling edge of DSTBp#. The third data strobe (falling edge of DSTBp#) must come approximately 1/2 BCLK period after the first falling edge of DSTBp#. The last data strobe (falling edge of DSTBn#) must come approximately 3/4 BCLK period after the first falling edge of DSTBp#.
- This specification applies only to DSTBN[3:0]# and is measured to the second falling edge of the strobe.

Table 2-22. Miscellaneous Signals AC Specifications

T# Parameter	Min	Max	Unit	Figure	Notes 1, 2, 3
T35: GTL+ asynchronous input pulse width	6		BCLKs		4
T36: PWRGOOD to RESET# deassertion time	1	10	ms	2-17	
T37: BCLK valid before PWRGOOD active	10		BCLKs	2-17	5
T38: PROCHOT#, FORCEPR# pulse width	500		µs	2-13	6
T39: THERMTRIP# assertion until V _{CC} removal		500	ms	2-14	7
T40: FERR# valid delay from STPCLK# deassertion	0	5	BCLKs	2-19	
T41: V _{CC} to PWRGOOD assertion time	1	500	ms	2-17	

NOTES:

- All AC timings for the GTL+ asynchronous signals are referenced to the BCLK0 rising edge at Crossing Voltage (V_{CROSS}). All GTL+ asynchronous signal timings are referenced at GTLREF. PWRGOOD is referenced to the BCLK0 rising edge at 0.5 * V_{TT}.
- These signals may be driven asynchronously.
- Refer to [Section 8.2](#) for additional timing requirements for entering and leaving low power states.
- A minimum pulse width of 500µs is recommended when FORCEPR# is asserted by the system.
- Refer to the PWRGOOD definition for more details regarding the behavior of the signal.
- Length of assertion for PROCHOT# does not equal TCC activation time. Time is required after the assertion or deassertion of PROCHOT# for the processor to enable or disable the TCC. Additionally, time is allocated after the assertion or deassertion of PROCHOT# for the processor to complete current instruction execution. This specification applies to the PROCHOT# signal when asserted by the processor and the FORCEPR# signal when asserted by the system.
- Intel recommends the V_{tt} power supply also be removed upon assertion of THERMTRIP#.

Table 2-23. Front Side Bus AC Specifications (Reset Conditions)

T# Parameter	Min	Max	Unit	Figure	Notes
T47: Reset Configuration Signals (A[39:3]#, BR[1:0], INT#, SMI#) Setup Time	4		BCLK	2-18	1
T45: Reset Configuration Signals (A[39:3]#, INT#, SMI#) HoldTime	2	50	BCLKs	2-17	2
T46: Reset Configuration Signals BR[1:0]# Hold Time	2	2	BCLKs	2-17	2

NOTES:

- Before the clock that deasserts RESET#.
- After the clock that deasserts RESET#.

Table 2-24. TAP Signal Group AC Specifications

T# Parameter	Min	Max	Unit	Figure	Notes 1, 2
T55: TCK Period	13.3		ns	2-6	3
T61: TDI, TMS Setup Time	1.5		ns	2-12	4, 5
T62: TDI, TMS Hold Time	3.0		ns	2-12	4, 5
T63: TDO Clock to Output Delay	0.5	3.6	ns	2-12	6
T64: TRST# Assert Time	2		TCK	2-13	7

NOTES:

- Not 100% tested. These parameters are based on design characterization.
- It is recommended that TMS be asserted while TRST# is being deasserted.
- This specification is based on the capabilities of the ITP-XDP debug port tool, not on processor silicon.
- Referenced to the rising edge of TCK.
- Specification for a minimum swing defined between TAP V_{T-} to V_{T+}. This assumes a minimum edge rate of 0.5 V/ns.
- Referenced to the falling edge of TCK.
- TRST# must be held asserted for 2 TCK periods to be guaranteed that it is recognized by the processor.

Table 2-25. VIDPWRGD AC Specifications

T# Parameter	Min	Max	Unit	Figure	Notes
T70: VIDPWRGD rise time		150	ns	2-18	1
T71: V_{TT} to VIDPWRGD delay time	1	10	ms	2-18	
T72: V_{TT} to VIDPWRGD deassertion time		1	ms	2-18	2
T73: VIDPWRGD to V_{CC} delay time	0		ms	2-17	

NOTES:

- Rise time is measured between 10% and 90% points on the waveform.
- Specification refers to the time between VIDPWRGD = $V_{TT} - 20\%$ and VIDPWRGD = V_{IL} .

Table 2-26. VID Signal Group AC Timing Specifications

T# Parameter	Min	Max	Unit	Figure	Notes
T80: VID Step Time	5		μ s	2-21	
T81: VID Dwell Time	50		μ s	2-21	
T82: VID Down Transition to Valid V_{CC} (min)		0	μ s	2-20, 2-21	
T83: VID Up Transition to Valid V_{CC} (min)		50	μ s	2-20, 2-21	
T84: VID Down Transition to Valid V_{CC} (max)		50	μ s	2-20, 2-21	
T85: VID Up Transition to Valid V_{CC} (max)		0	μ s	2-20, 2-21	

Table 2-27. SMBus Signal Group AC Specifications

T# Parameter	Min	Max	Unit	Figure	Notes 1, 2
T90: SM_CLK Frequency	10	100	KHz		
T91: SM_CLK Period	10	100	μ s		
T92: SM_CLK High Time	4.0	N/A	μ s	2-15	
T93: SM_CLK Low Time	4.7	N/A	μ s	2-15	
T94: SMBus Rise Time	0.02	1.0	μ s	2-15	3
T95: SMBus Fall Time	0.02	0.3	μ s	2-15	3
T96: SMBus Output Valid Delay	0.1	4.5	μ s	2-16	
T97: SMBus Input Setup Time	250	N/A	ns	2-15	
T98: SMBus Input Hold Time	300	N/A	ns	2-15	
T99: Bus Free Time	4.7	N/A	μ s	2-15	4, 5
T100: Hold Time after Repeated Start Condition	4.0	N/A	μ s	2-15	
T101: Repeated Start Condition Setup Time	4.7	N/A	μ s	2-15	
T102: Stop Condition Setup Time	4.0	N/A	μ s	2-15	

NOTES:

- These parameters are based on design characterization and are not tested.
- All AC timings for the SMBus signals are referenced at V_{IL_MAX} or V_{IL_MIN} and measured at the processor pins. Refer to [Figure 2-15](#).
- Rise time is measured from ($V_{IL_MAX} - 0.15V$) to ($V_{IH_MIN} + 0.15V$). Fall time is measured from ($0.9 * SM_VCC$) to ($V_{IL_MAX} - 0.15V$). DC parameters are specified in [Table 2-17](#).
- Minimum time allowed between request cycles.
- Following a write transaction, an internal write cycle time of 10ms must be allowed before starting the next transaction

2.12 Processor AC Timing Waveforms

The following figures are used in conjunction with the AC timing tables (Table 2-20 through Table 2-27).

Note: For Figure 2-6 through Figure 2-18, the following apply:

1. All common clock AC timings for AGTL+ signals are referenced to the Crossing Voltage (V_{CROSS}) of the BCLK[1:0] at rising edge of BCLK0. All common clock AGTL+ signal timings are referenced at GTLREF at the processor core.
2. All source synchronous AC timings for AGTL+ signals are referenced to their associated strobe (address or data) at GTLREF. Source synchronous data signals are referenced to the falling edge of their associated data strobe. Source synchronous address signals are referenced to the rising and falling edge of their associated address strobe. All source synchronous AGTL+ signal timings are referenced at GTLREF at the processor silicon.
3. All AC timings for AGTL+ strobe signals are referenced to BCLK[1:0] at V_{CROSS} . All AGTL+ strobe signal timings are referenced at GTLREF at the processor silicon.
4. All AC timings for the TAP signals are referenced to the TCK at $0.5 * V_{TT}$ at the processor pins. All TAP signal timings (TMS, TDI, etc.) are referenced at $0.5 * V_{TT}$ at the processor pins.
5. All AC timings for the SMBus signals are referenced to the SM_CLK at $0.5 * SM_VCC$ at the processor pins. All SMBus signal timings (SM_DAT, SM_CLK, etc.) are referenced at V_{IL_MAX} or V_{IL_MIN} at the processor pins.

Figure 2-5. Electrical Test Circuit

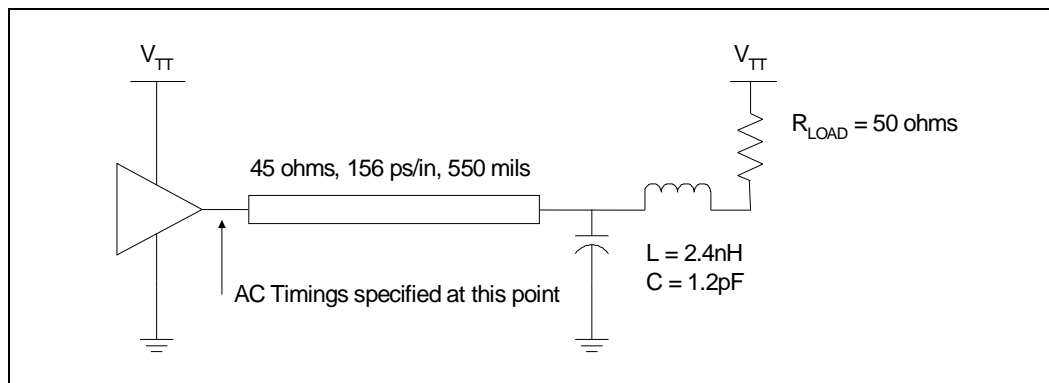

Figure 2-6. TCK Clock Waveform

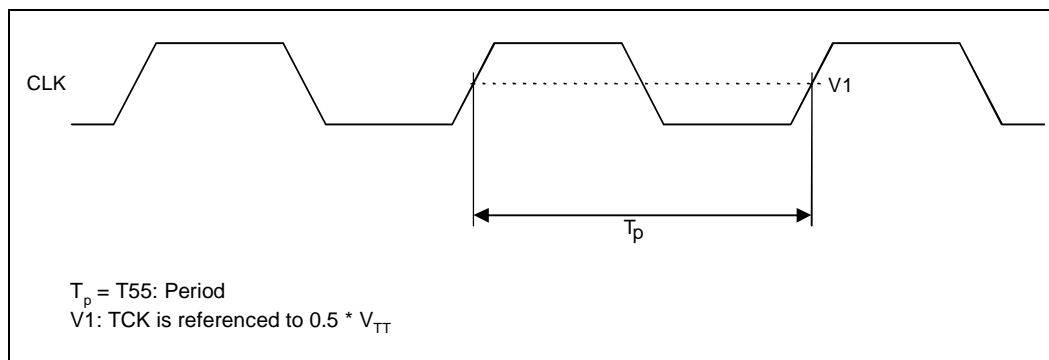

Figure 2-7. Differential Clock Waveform

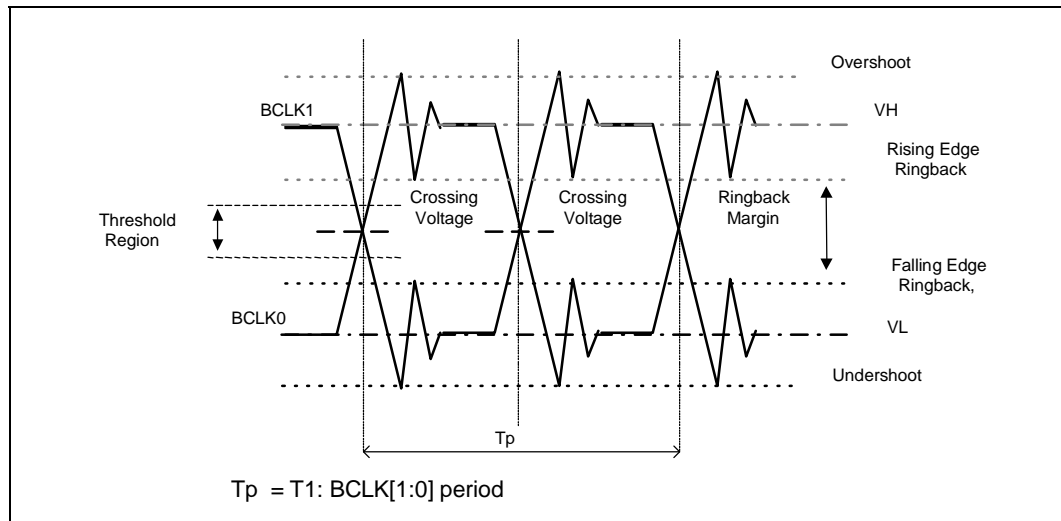

Figure 2-8. Differential Clock Crosspoint Specification

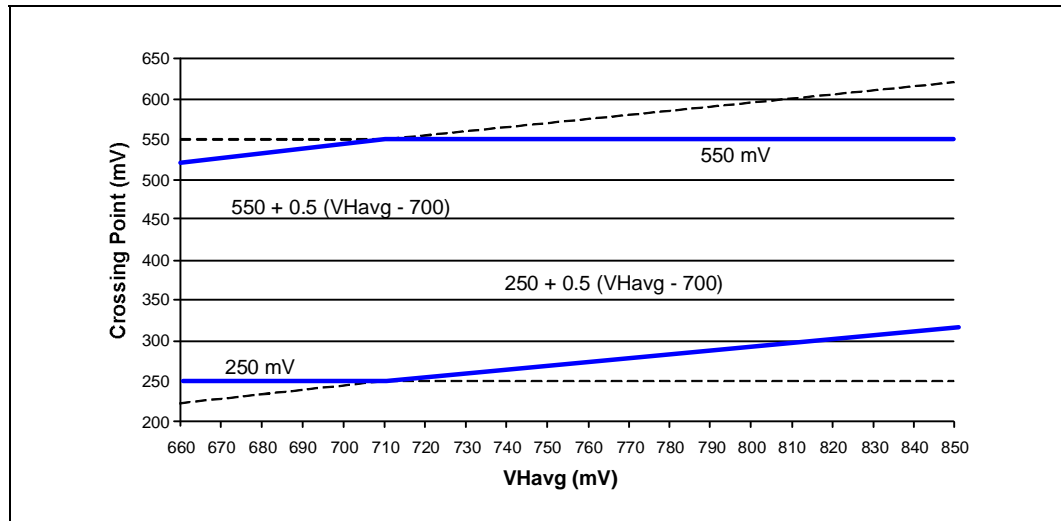

Figure 2-9. Front Side Bus Common Clock Valid Delay Timing Waveform

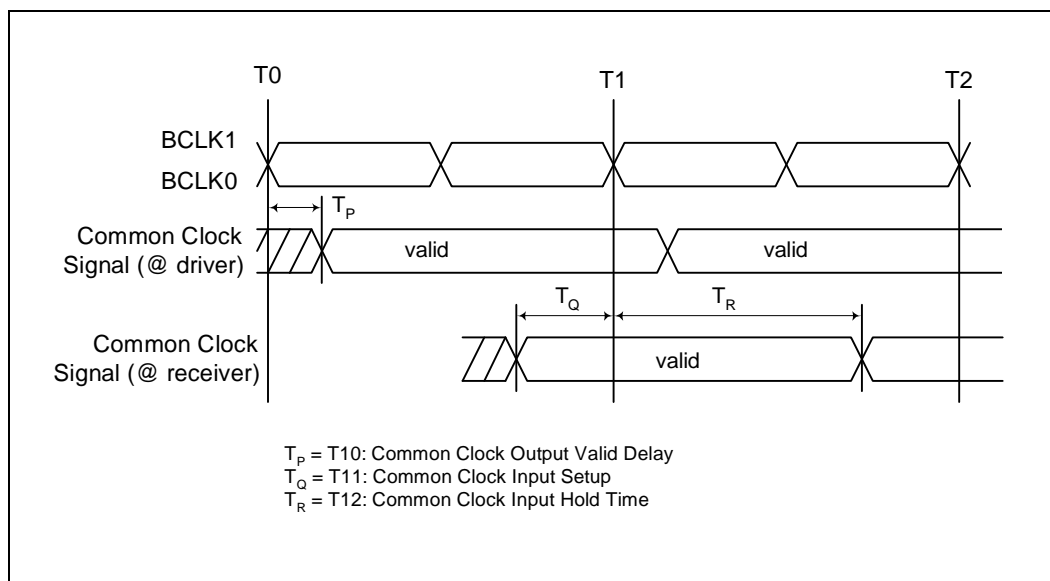

Figure 2-10. Source Synchronous 2X (Address) Timing Waveform

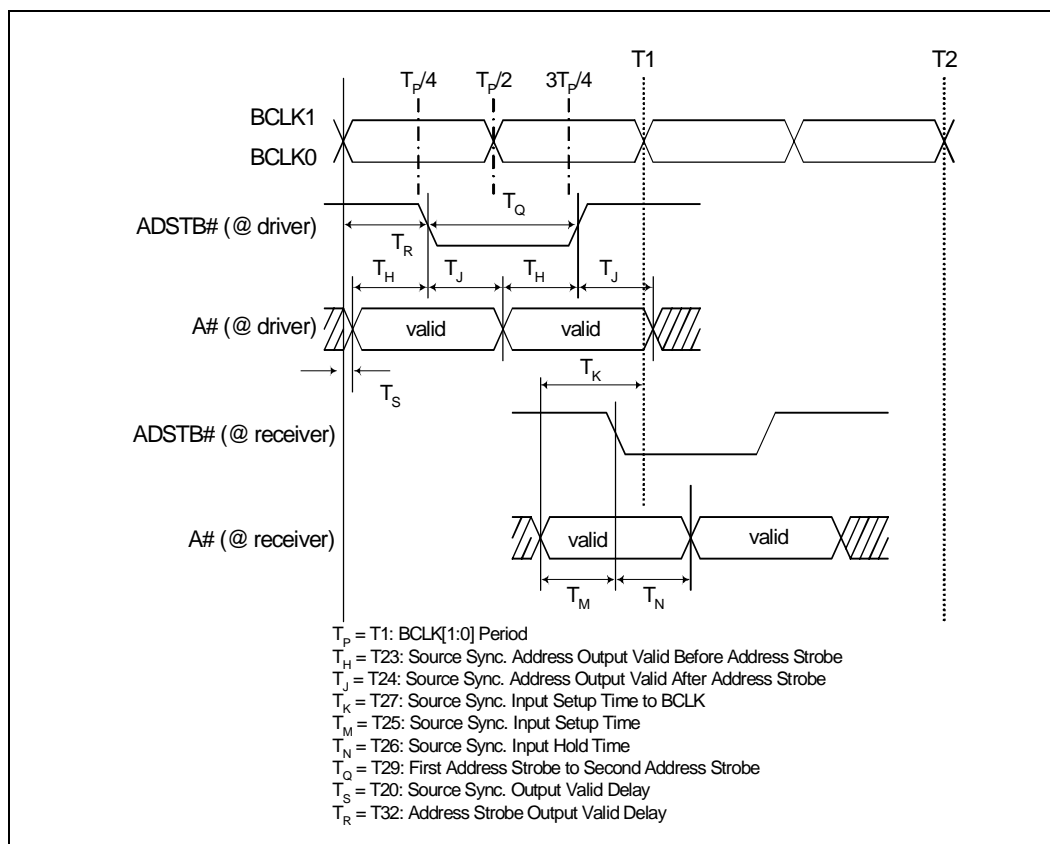

Figure 2-11. Source Synchronous 4X (Data) Timing Waveform

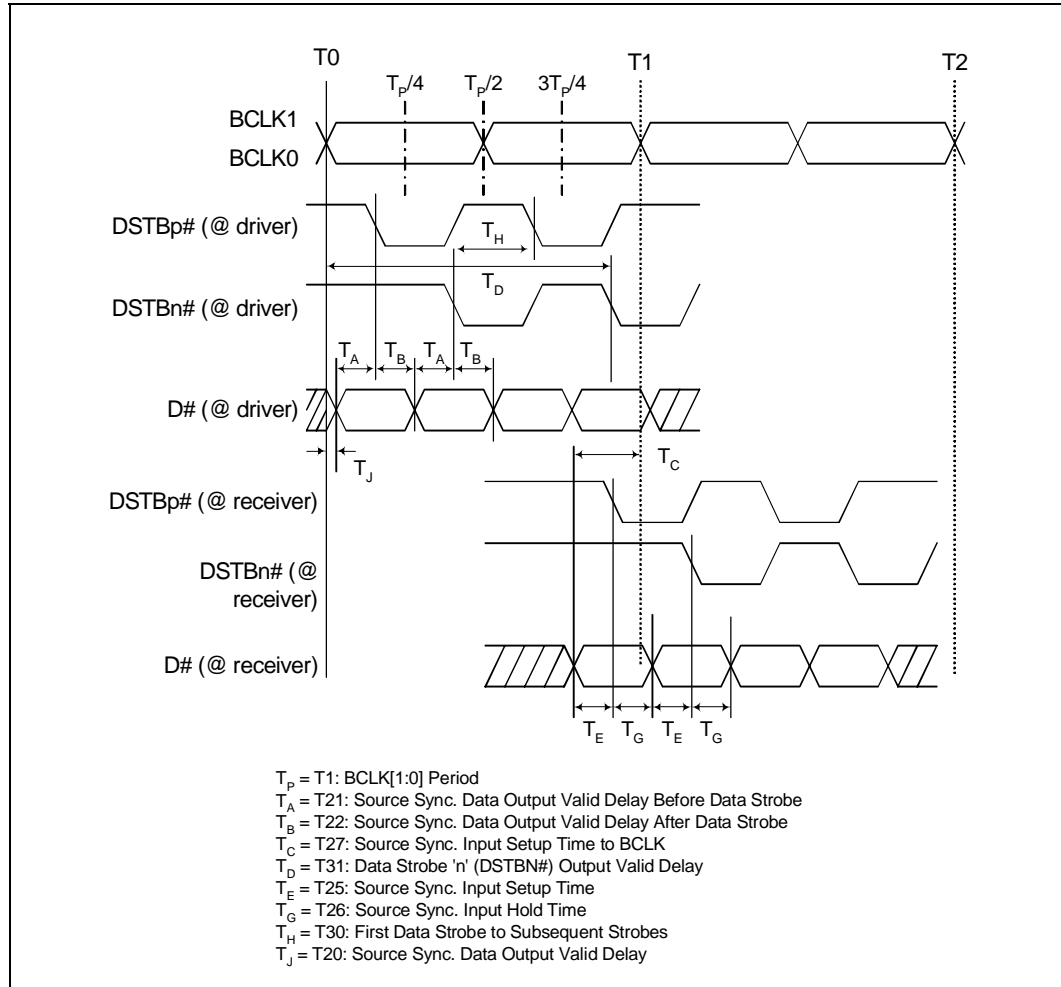

Figure 2-12. TAP Valid Delay Timing Waveform

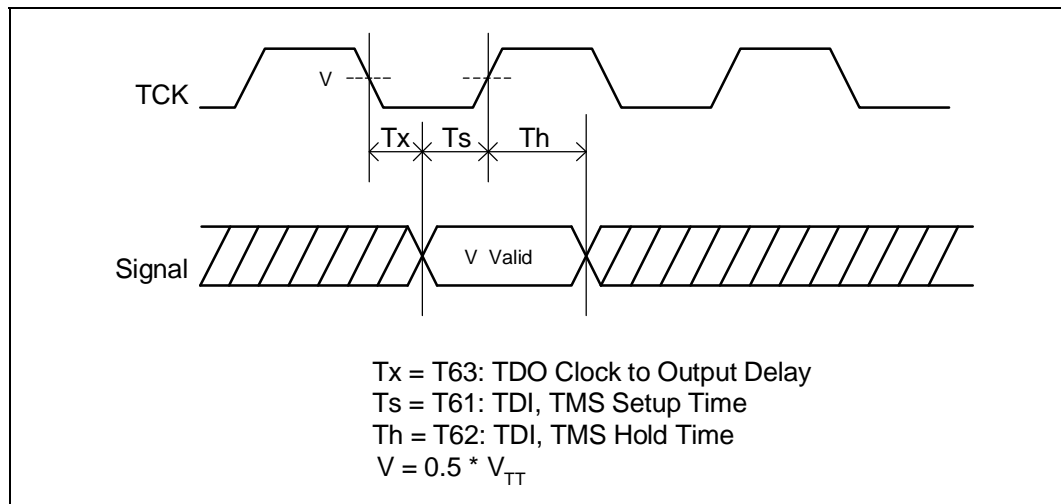

Figure 2-13. Test Reset (TRST#), Async GTL+ Input, and PROCHOT# Timing Waveform

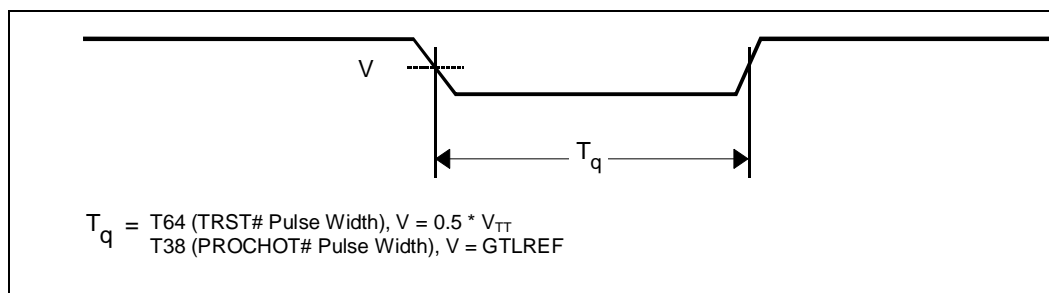

Figure 2-14. THERMTRIP# Power Down Sequence

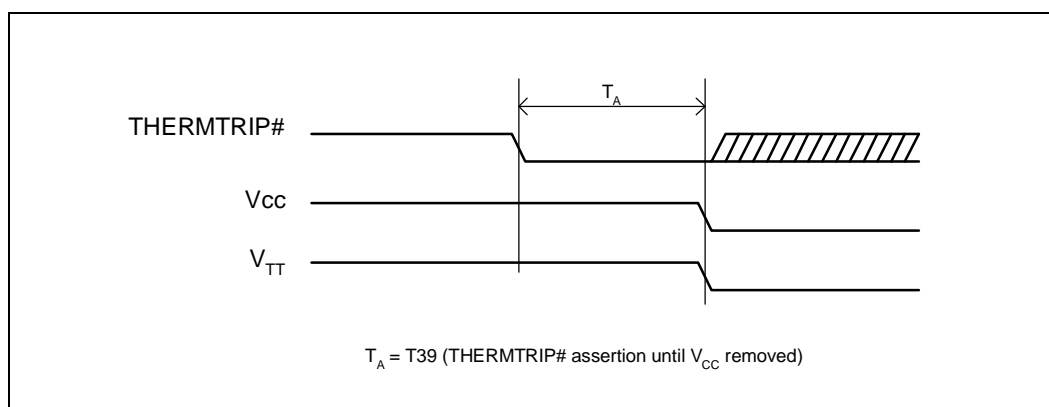

Figure 2-15. SMBus Timing Waveform

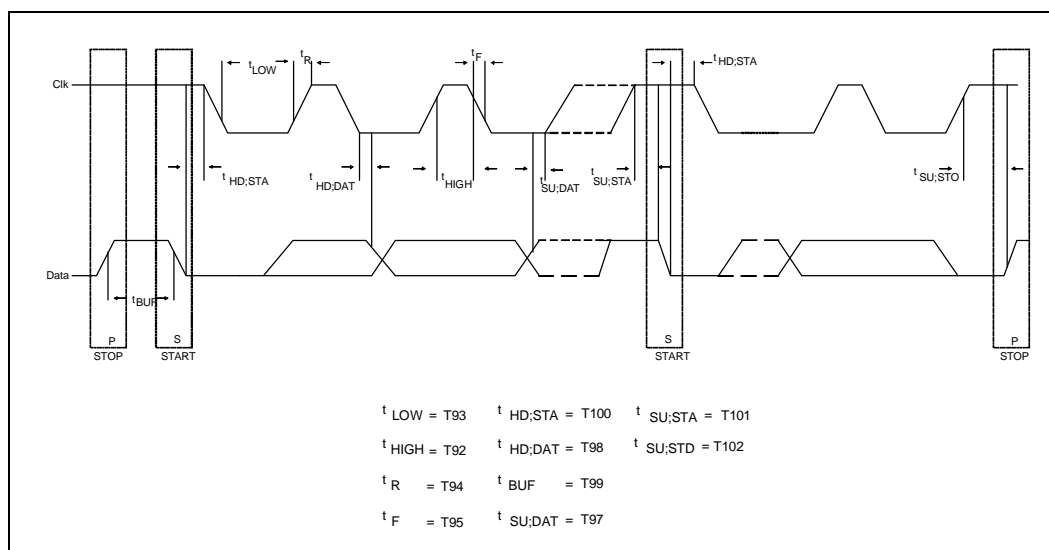

Figure 2-16. SMBus Valid Delay Timing Waveform

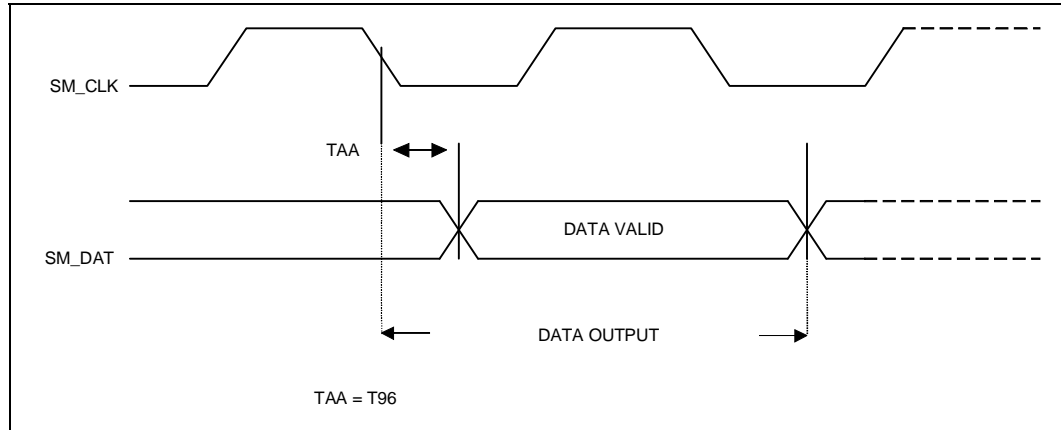

Figure 2-17. Voltage Sequence Timing Requirements

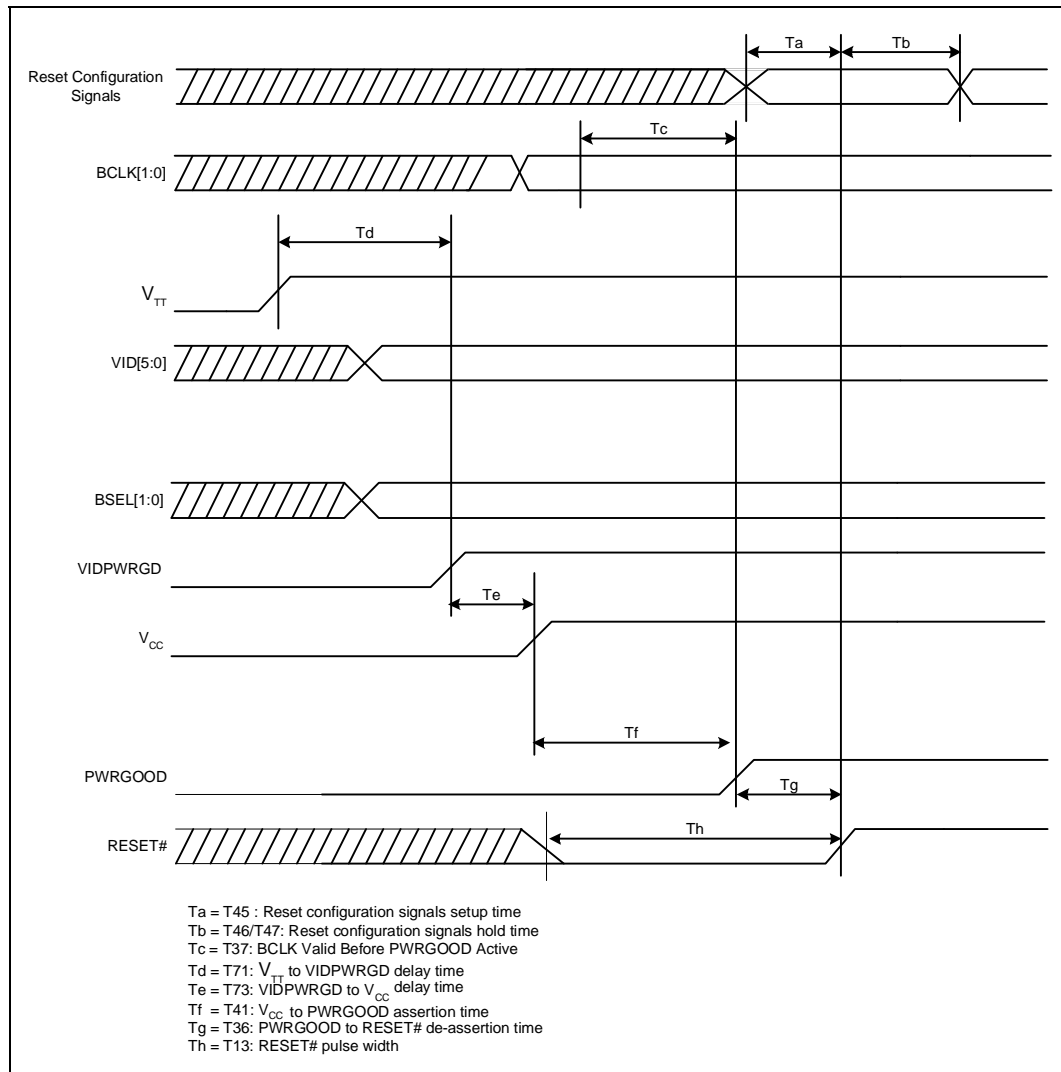

Figure 2-18. VIDPWRGD Timing Requirements

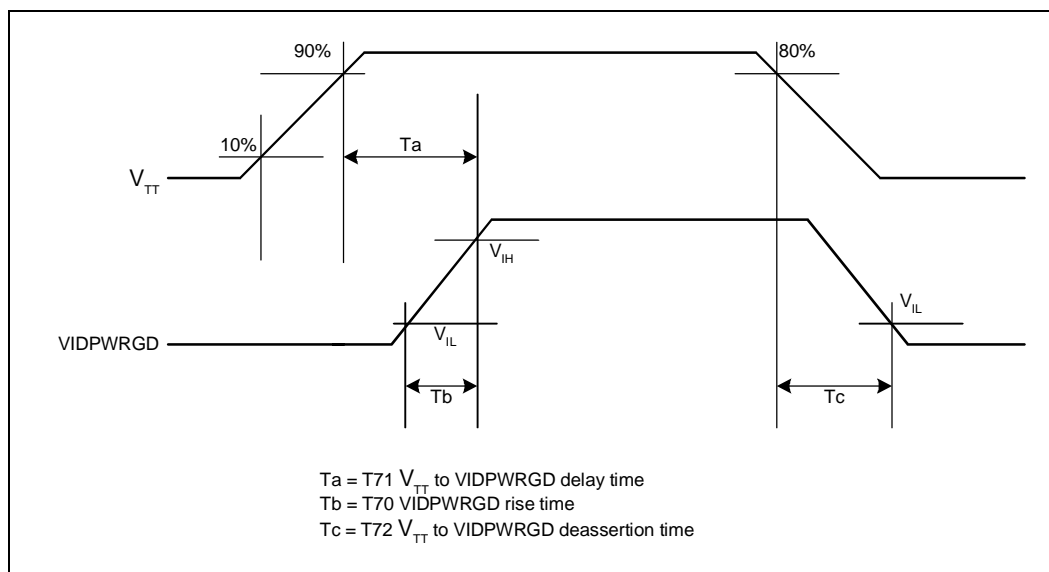

Figure 2-19. FERR#/PBE# Valid Delay Timing

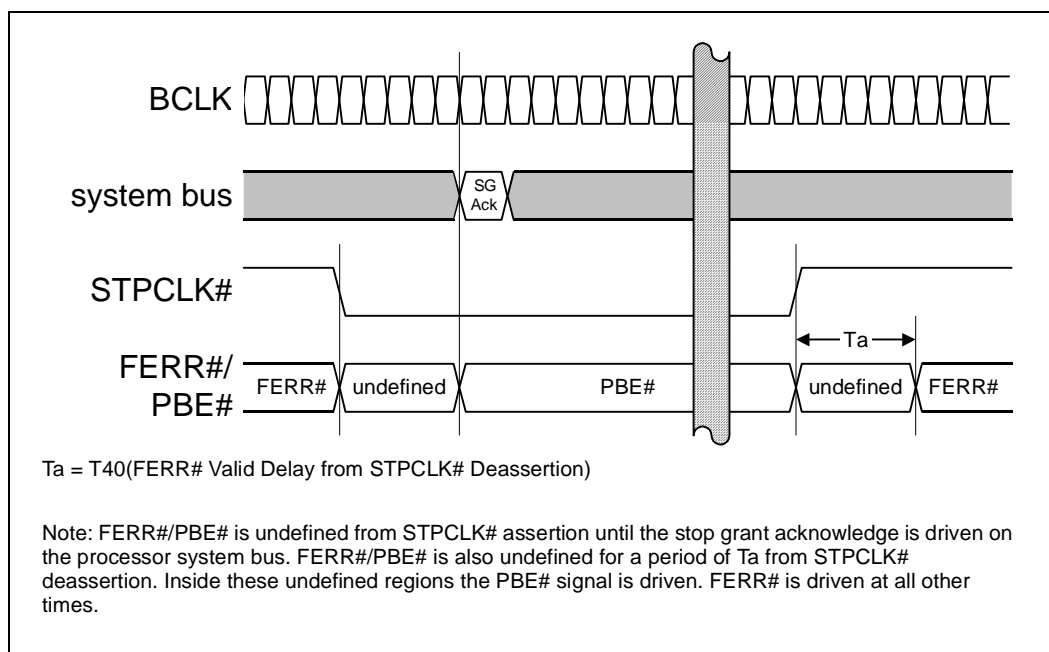

Figure 2-20. VID Signal Group AC Specifications

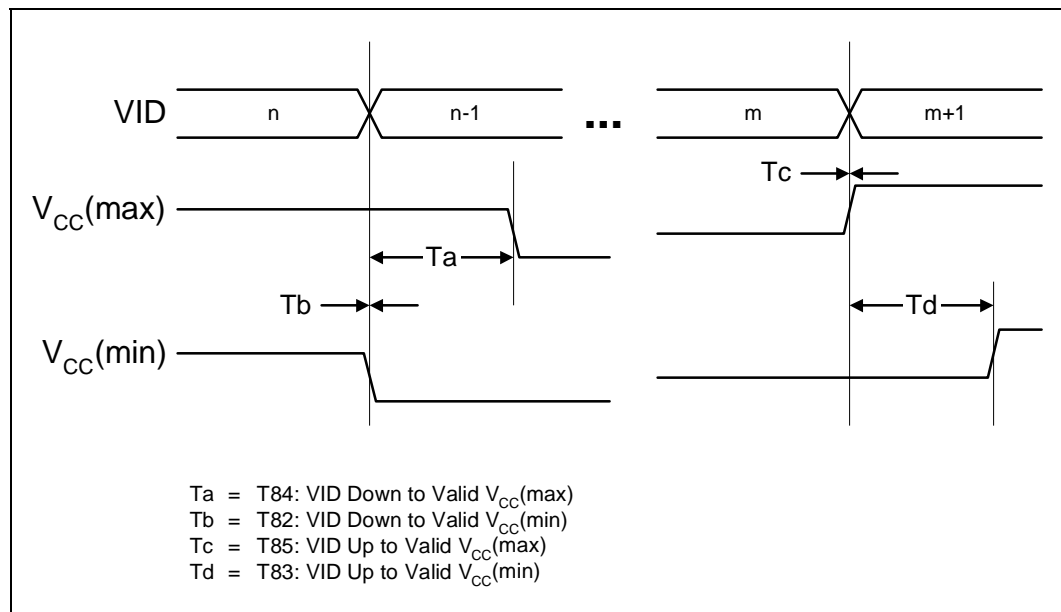
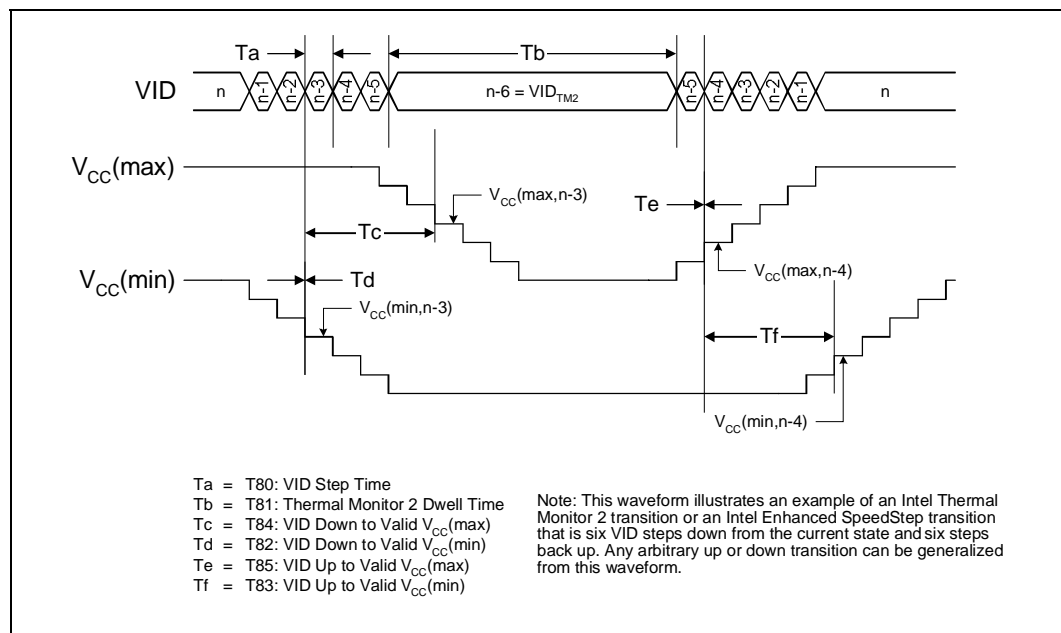

Figure 2-21. VID Transition Times



§



3 Front Side Bus Signal Quality Specifications

Source synchronous data transfer requires the clean reception of data signals and their associated strobes. Ringing below receiver thresholds, non-monotonic signal edges, and excessive voltage swings will adversely affect system timings. Ringback and signal non-monotonicity cannot be tolerated since these phenomena may inadvertently advance receiver state machines. Excessive signal swings (overshoot and undershoot) are detrimental to silicon gate oxide integrity, and can cause device failure if absolute voltage limits are exceeded. Overshoot and undershoot can also cause timing degradation due to the build up of inter-symbol interference (ISI) effects.

For these reasons, it is crucial that the designer work towards a solution that provides acceptable signal quality across all systematic variations encountered in volume manufacturing.

This section documents signal quality metrics used to derive topology and routing guidelines through simulation. All specifications are specified at the processor core (pad measurements).

Specifications for signal quality are for measurements at the processor core only and are only observable through simulation. The same is true for all FSB AC timing specifications in [Section 2.11](#). Therefore, proper simulation of the 64-bit Intel® Xeon™ processor MP FSB is the only way to verify proper timing and signal quality.

3.1 Front Side Bus Signal Quality Specifications and Measurement Guidelines

3.1.1 Ringback Guidelines

Many scenarios have been simulated to generate a set of AGTL+ layout guidelines which are available in the appropriate platform design guide.

[Table 3-1](#) provides the signal quality specifications for the AGTL+ and GTL+ asynchronous signal groups. [Table 3-2](#) demonstrates the signal quality specification for the TAP signal group. These specifications are for use in simulating signal quality at the processor pads.

Maximum allowable overshoot and undershoot specifications for a given duration of time are detailed in [Table 3-3](#) through [Table 3-6](#). FSB ringback tolerance for AGTL+ and GTL+ asynchronous signal groups are shown in [Figure 3-1](#) (low-to-high transitions) and [Figure 3-2](#) (high-to-low transitions).

The TAP signal group includes hysteresis on the input buffers and thus has relaxed ringback requirements when compared to the other buffer types. [Figure 3-3](#) shows the FSB ringback tolerance for low-to-high transitions and [Figure 3-4](#) for high-to-low transitions. The hysteresis values V_{t+} and V_{t-} can be found in [Table 2-15](#).

Table 3-1. Ringback Specifications for AGTL+ and GTL+ Asynchronous Signal Groups

Signal Group	Transition	Maximum Ringback (with Input Diodes Present)	Unit	Figure	Notes
AGTL+, Async GTL+	Low → High	$GTLREF + (0.06 * V_{TT})$	V	3-1	1, 2, 3, 4, 5, 6
AGTL+, Async GTL+	High → Low	$GTLREF - (0.06 * V_{TT})$	V	3-2	1, 2, 3, 4, 5, 6

NOTES:

1. All signal integrity specifications are measured at the processor core (pads).
2. Unless otherwise noted, all specifications in this table apply to all 64-bit Intel® Xeon™ processor MP with 1MB L2 cache frequencies.
3. Specifications are for the edge rate of 1.8- 2.2V/ns.
4. All values specified by design characterization.
5. Please see [Section 3.1.3](#) for maximum allowable overshoot.
6. Ringback between $GTLREF + (0.06 * V_{TT})$ and $GTLREF - (0.06 * V_{TT})$ is not supported.

Figure 3-1. Low-to-High Front Side Bus Receiver Ringback Tolerance

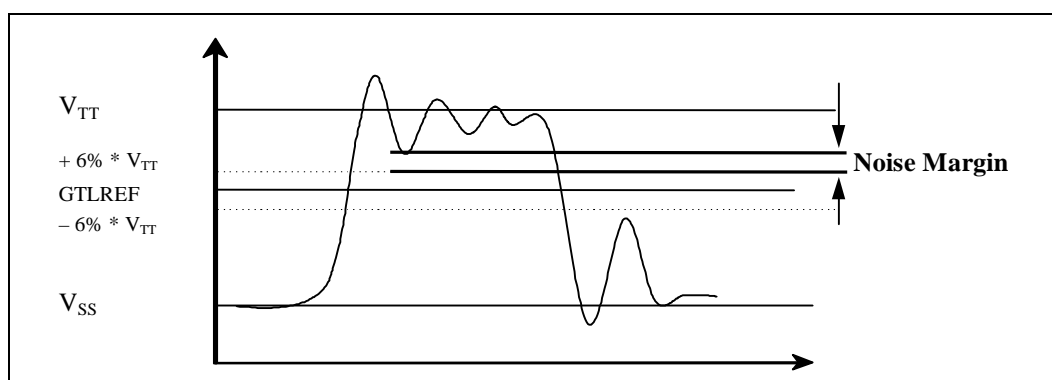

Figure 3-2. High-to-Low Front Side Bus Receiver Ringback Tolerance

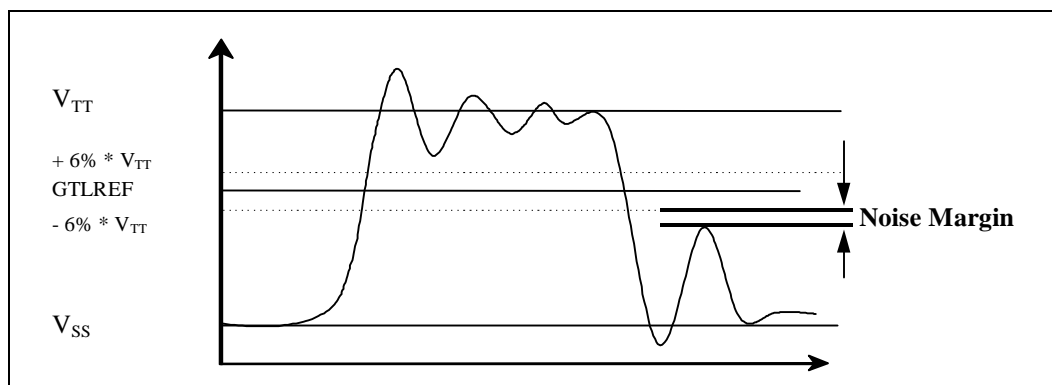

Table 3-2. Ringback Specifications for PWRGOOD and TAP Signal Groups

Signal Group	Transition	Maximum Ringback (with Input Diodes Present)	Unit	Figure	Notes
PWRGOOD and TAP	Low → High	$V_{t+(max)}$ to $V_{t-(max)}$	V	3-3	1, 2, 3, 4
PWRGOOD and TAP	High → Low	$V_{t-(min)}$ to $V_{t+(min)}$	V	3-4	1, 2, 3, 4

NOTES:

1. All signal integrity specifications are measured at the processor core (pads).
2. Unless otherwise noted, all specifications in this table apply to all 64-bit Intel® Xeon™ processor MP with 1MB L2 cache frequencies.
3. All values specified by design characterization.
4. Please see [Section 3.1.3](#) for maximum allowable overshoot.

Figure 3-3. Low-to-High Receiver Ringback Tolerance for PWRGOOD and TAP Signals

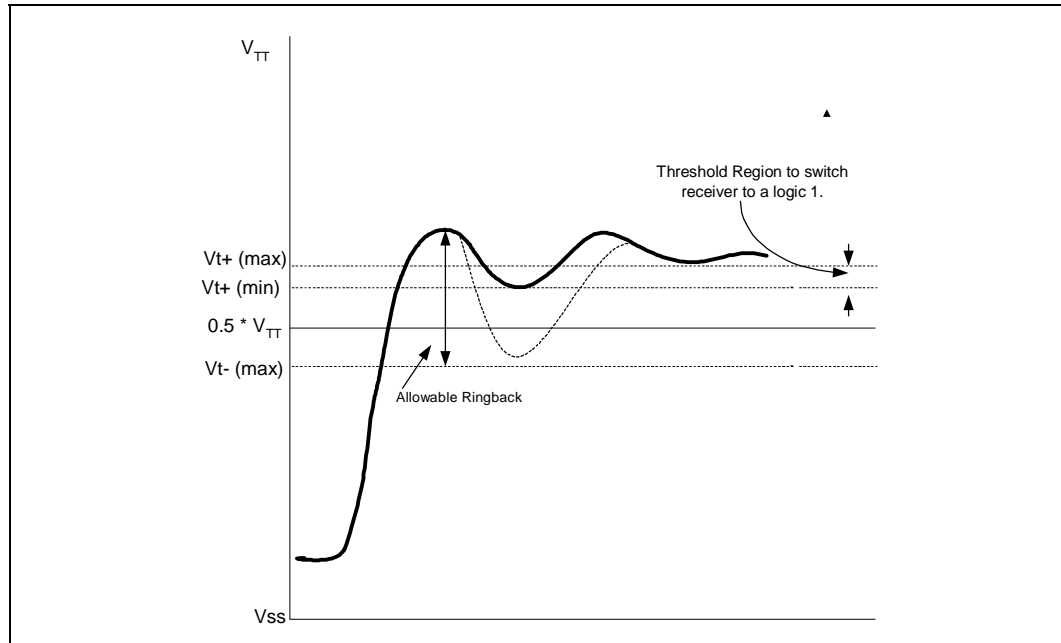
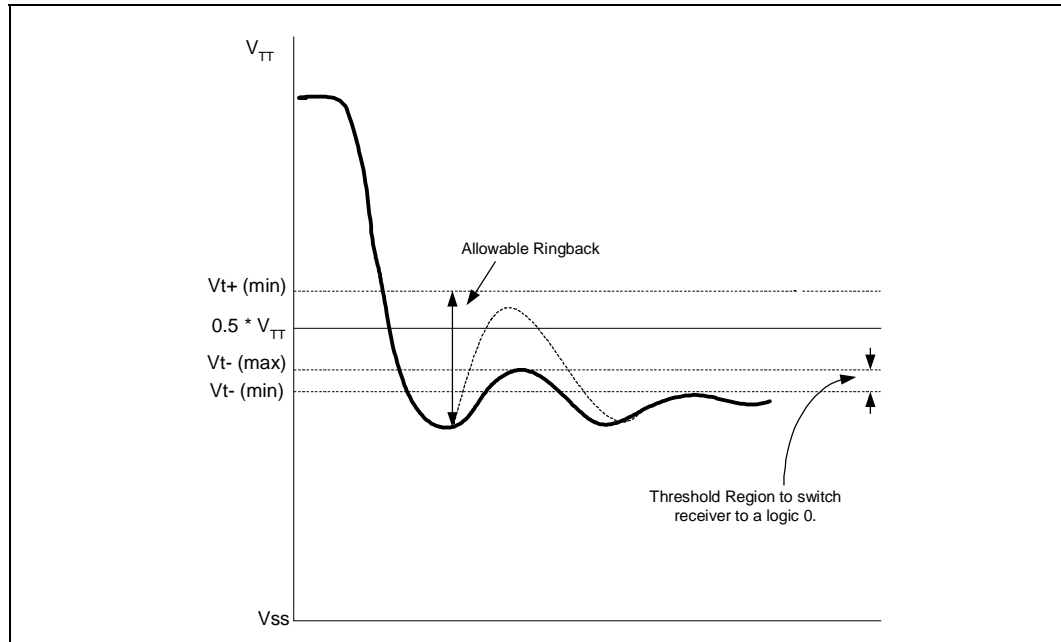

Figure 3-4. High-to-Low Receiver Ringback Tolerance for PWRGOOD and TAP Signals



3.1.2 Overshoot/Undershoot Guidelines

Overshoot (or undershoot) is the absolute value of the maximum voltage above or below V_{SS} . The overshoot/undershoot specifications limit transitions beyond V_{TT} or V_{SS} due to the fast signal edge rates. The processor can be damaged by single and/or repeated overshoot or undershoot events on any input, output, or I/O buffer if the charge is large enough (i.e., if the over/undershoot is great enough). Determining the impact of an overshoot/undershoot condition requires knowledge of the magnitude, the pulse duration, and the activity factor (AF). Permanent damage to the processor is the likely result of excessive overshoot/undershoot.

When performing simulations to determine the impact of overshoot and undershoot effects, ESD diodes must be properly characterized. ESD protection diodes do not act as voltage clamps and will not provide overshoot or undershoot protection. ESD diodes modeled within Intel signal integrity models do not clamp undershoot or overshoot and will yield correct simulation results. If other signal integrity models are being used to characterize the 64-bit Intel® Xeon™ processor MP with 1MB L2 cache FSB, care must be taken to ensure that ESD models do not clamp extreme voltage levels. Intel signal integrity models also contain I/O capacitance characterization. Therefore, removing the ESD diodes from a signal integrity model will impact results and may yield excessive overshoot/undershoot.

3.1.3 Overshoot/Undershoot Magnitude

Magnitude describes the maximum potential difference between a signal and its voltage reference level. For the 64-bit Intel® Xeon™ processor MP with 1MB L2 cache, both are referenced to V_{SS} . It is important to note that overshoot and undershoot conditions are separate and their impact must be determined independently.

The pulse magnitude, duration, and activity factor must all be used to determine if the overshoot/undershoot pulse is within specifications.

3.1.4 Overshoot/Undershoot Pulse Duration

Pulse duration describes the total amount of time that an overshoot/undershoot event exceeds the overshoot/undershoot reference voltage. The total time could encompass several oscillations above the reference voltage. Multiple overshoot/undershoot pulses within a single overshoot/undershoot event may need to be measured to determine the total pulse duration.

Note: Oscillations below the reference voltage cannot be subtracted from the total overshoot/undershoot pulse duration.

3.1.5 Activity Factor

Activity Factor (AF) describes the frequency of overshoot (or undershoot) occurrence relative to a clock. Since the highest frequency of assertion of any common clock signal is every other clock, an AF = 1 indicates that the specific overshoot (or undershoot) waveform occurs every other clock cycle. Thus, an AF = 0.01 indicates that the specific overshoot (or undershoot) waveform occurs one time in every 200 clock cycles.

For source synchronous signals (address, data, and associated strobes), the activity factor is in reference to the strobe edge. The highest frequency of assertion of any source synchronous signal is every active edge of its associated strobe. So, an AF = 1 indicates that the specific overshoot (or undershoot) waveform occurs every strobe cycle.

The specifications provided in [Table 3-3](#) through [Table 3-6](#) show the maximum pulse duration allowed for a given overshoot/undershoot magnitude at a specific activity factor. Each table entry is independent of all others (meaning that the pulse duration reflects the existence of overshoot/undershoot events of that magnitude ONLY). A platform with an overshoot/undershoot that just meets the pulse duration for a specific magnitude where the $AF < 1$ means that there can be no other overshoot/undershoot events, even of lesser magnitude (note that if $AF = 1$, then the event occurs at all times and no other events can occur).

Note: AF for common clock AGTL+ signals is referenced to BCLK[1:0] frequency.

Note: AF for source synchronous (2x) signals is referenced to ADSTB[1:0]#.

Note: AF for source synchronous (4x) signals is referenced to DSTBP[3:0]# and DSTBN[3:0]#.

3.1.6 Reading Overshoot/Undershoot Specification Tables

The overshoot/undershoot specification for the 64-bit Intel® Xeon™ processor MP with 1MB L2 cache is not a simple single value. Instead, many factors are needed to determine what the over/undershoot specification is. In addition to the magnitude of the overshoot, the following parameters must also be known: the width of the overshoot and the AF. To determine the allowed overshoot for a particular overshoot event, the following must be done:

1. Determine the *signal group* that particular signal falls into. For AGTL+ signals operating in the 4x source synchronous domain, use [Table 3-3](#). For AGTL+ signals operating in the 2x source synchronous domain, use [Table 3-4](#). If the signal is an AGTL+ signal operating in the common clock domain, use [Table 3-5](#). Finally, all other signals are referenced in [Table 3-6](#).
2. Determine the *magnitude* of the overshoot or the undershoot (relative to V_{SS}).
3. Determine the *activity factor* (how often does this overshoot occur).
4. Next, from the appropriate specification table, determine the *maximum pulse duration* (in nanoseconds) allowed.
5. Compare the specified maximum pulse duration to the signal being measured. If the pulse duration measured is less than the pulse duration shown in the table, then the signal meets the specifications.

Undershoot events must be analyzed separately from overshoot events as they are mutually exclusive.

3.1.7 Determining if a System Meets the Overshoot/Undershoot Specifications

The overshoot/undershoot specifications listed in the following tables specify the allowable overshoot/undershoot for a single overshoot/undershoot event. Most systems will have multiple overshoot and/or undershoot events that each have their own set of parameters (duration, AF and magnitude). While each overshoot on its own may meet the overshoot specification, evaluate the cumulative overshoot of every cycle. A guideline to ensure a system passes the overshoot and undershoot specifications is shown below. Results from simulation may also be evaluated by utilizing the 64-bit Intel® Xeon™ Processor MP with 1MB L2 Cache Overshoot Checker Tool through the use of time-voltage data files.

1. If only one overshoot/undershoot event magnitude occurs, ensure it meets the over/undershoot specifications in the following tables OR
2. If multiple overshoots and/or multiple undershoots occur, measure the worst case pulse duration for each magnitude and compare the results against the AF = 1 specifications. If all of these worst case overshoot or undershoot events meet the specifications (measured time < specifications) in the table (where AF=1), then the system passes.

The following notes apply to [Table 3-3](#) through [Table 3-6](#).

NOTES:

1. Absolute Maximum Overshoot is measured referenced to V_{SS} . Pulse Duration of overshoot is measured relative to V_{TT} .
2. Absolute Maximum Undershoot and Pulse Duration of undershoot is measured relative to V_{SS} .
3. Ringback below V_{TT} cannot be subtracted from overshoots/undershoots.
4. Lesser undershoot does not allocate longer or larger overshoot.
5. OEM's are strongly encouraged to follow Intel layout guidelines.
6. All values specified by design characterization.

Table 3-3. Source Synchronous (667 MHz) GTL+ Signal Group Overshoot/Undershoot Tolerance

Absolute Maximum Overshoot (V)	Absolute Maximum Undershoot (V)	Pulse Duration (ns) AF = 1	Pulse Duration (ns) AF = 0.1
1.55	-0.35	0.00	0.20
1.50	-0.30	0.10	0.80
1.45	-0.25	0.20	1.50
1.40	-0.20	0.70	1.50
1.35	-0.15	1.50	1.50
1.30	-0.10	1.50	1.50

NOTES:

1. These specifications are measured at the processor pad.
2. Assumes a BCLK period of 5 ns.
3. AF is referenced to associated source synchronous strobes.
4. Values in this table assume $V_{TT} = 1.20$ V

**Table 3-4. Source Synchronous (333 MHz) GTL+ Signal Group
Overshoot/Undershoot Tolerance**

Absolute Maximum Overshoot (V)	Absolute Maximum Undershoot (V)	Pulse Duration (ns) AF = 1	Pulse Duration (ns) AF = 0.1
1.55	-0.35	0.00	0.50
1.50	-0.30	0.20	1.50
1.45	-0.25	0.50	3.00
1.40	-0.20	1.50	3.00
1.35	-0.15	3.00	3.00
1.30	-0.10	3.00	3.00

NOTES:

1. These specifications are measured at the processor pad.
2. BCLK period is 5 ns.
3. AF is referenced to associated source synchronous strobe.
4. Values in this table assume $V_{TT} = 1.20$ V.

**Table 3-5. Common Clock (166 MHz) GTL+ Signal Group
Overshoot/Undershoot Tolerance**

Absolute Maximum Overshoot (V)	Absolute Maximum Undershoot (V)	Pulse Duration (ns) AF = 1	Pulse Duration (ns) AF = 0.1
1.55	-0.35	0.10	1.00
1.50	-0.30	0.30	3.00
1.45	-0.25	0.90	6.00
1.40	-0.20	2.90	6.00
1.35	-0.15	6.00	6.00
1.30	-0.10	6.00	6.00

NOTES:

1. These specifications are measured at the processor pad.
2. BCLK period is 5 ns.
3. AF is referenced to BCLK[1:0].
4. Values in this table assume $V_{TT} = 1.20$ V

**Table 3-6. Asynchronous GTL+, PWRGOOD Input and TAP Signal Groups\
Overshoot/Undershoot Tolerance**

Absolute Maximum Overshoot (V)	Absolute Maximum Undershoot (V)	Pulse Duration (ns) AF = 1	Pulse Duration (ns) AF = 0.1
1.55	-0.35	0.50	4.80
1.50	-0.30	1.5	15.1
1.45	-0.25	4.8	30.30
1.40	-0.20	14.8	30.30
1.35	-0.15	30.30	30.30
1.30	-0.10	30.30	30.30

NOTES:

1. These specifications are measured at the processor pad.
2. Signals which are asserted once per bootup (IERR#, PWRGOOD, THERMTRIP#) can tolerate a maximum overshoot of 1.86 V
3. These signals are assumed in a 33 MHz time domain.

Figure 3-5. Maximum Acceptable Overshoot/Undershoot Waveform

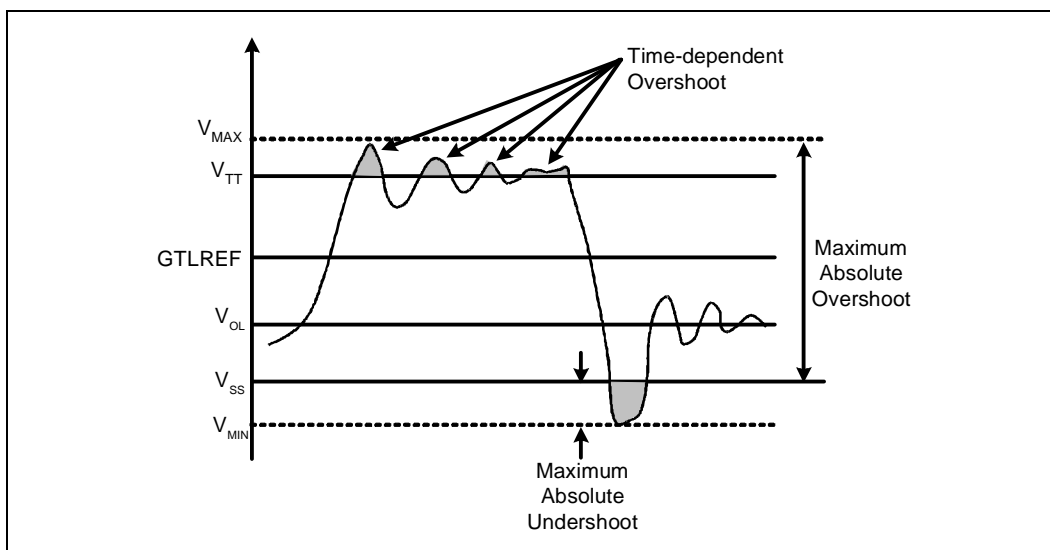

§

4 Mechanical Specifications

The 64-bit Intel® Xeon™ processor MP with 1MB L2 cache is packaged in a FC-mPGA4 package that interfaces with the motherboard via a mPGA604 socket. The package consists of a processor core mounted on a substrate pin-carrier. An IHS is attached to the package substrate and core and serves as the mating surface for processor component thermal solutions, such as a heatsink.

Figure 4-1 shows a sketch of the processor package components and how they are assembled together. Refer to the *mPGA604 Socket Design Guidelines* for complete details on the mPGA604 socket.

The package components shown in Figure 4-1 include the following:

1. IHS
2. Processor die
3. FC-mPGA4 package
4. Pin-side capacitors
5. Package pin

Figure 4-1. Processor Package Assembly Sketch

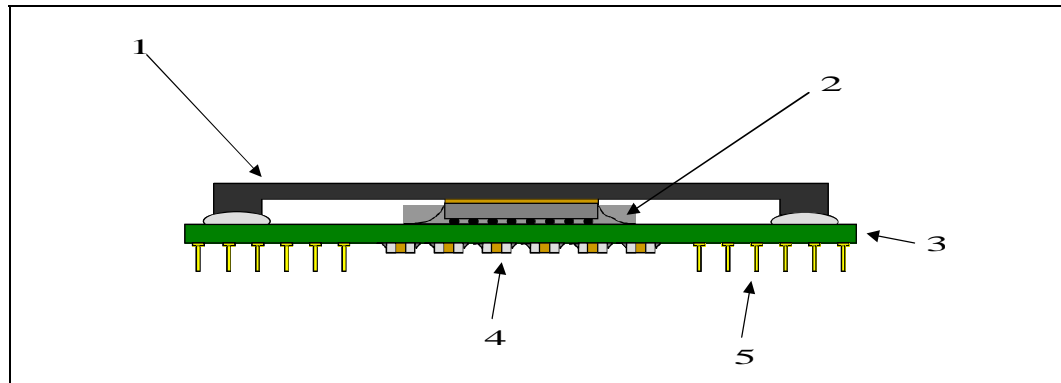

Note: Figure 4-1 is not to scale and is for reference only. The mPGA604 socket is not shown.

4.1 Package Mechanical Drawing

The package mechanical drawings are shown in Figure 4-2 and Figure 4-3. The drawings include dimensions necessary to design a thermal solution for the processor. These dimensions include:

1. Package reference with tolerances (total height, length, width, etc.)
2. IHS parallelism and tilt
3. Pin dimensions
4. Top-side and back-side component keepout dimensions
5. Reference datums

All drawing dimension are in mm [in].

Figure 4-2. Processor Package Drawing (Sheet 1 of 2)

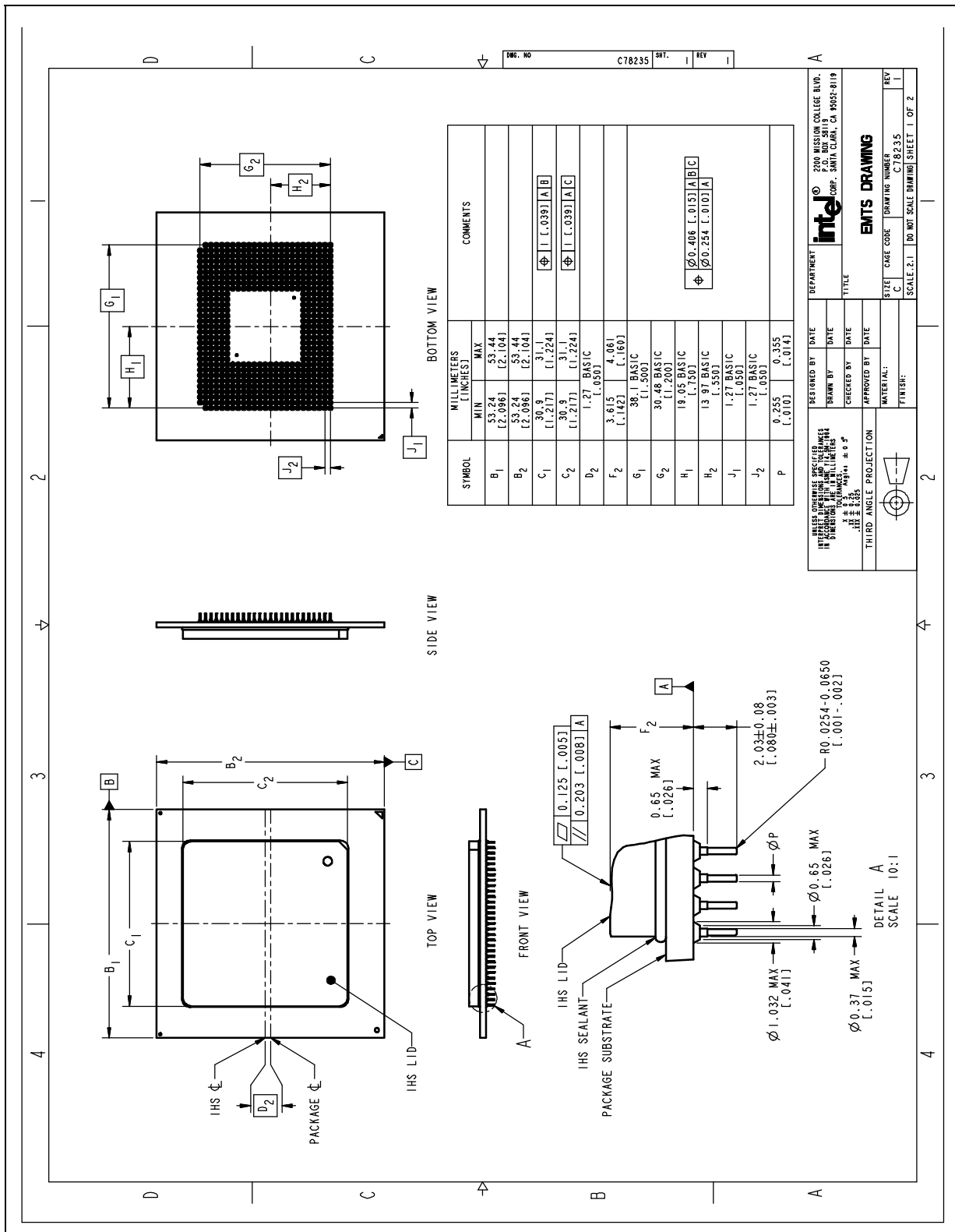
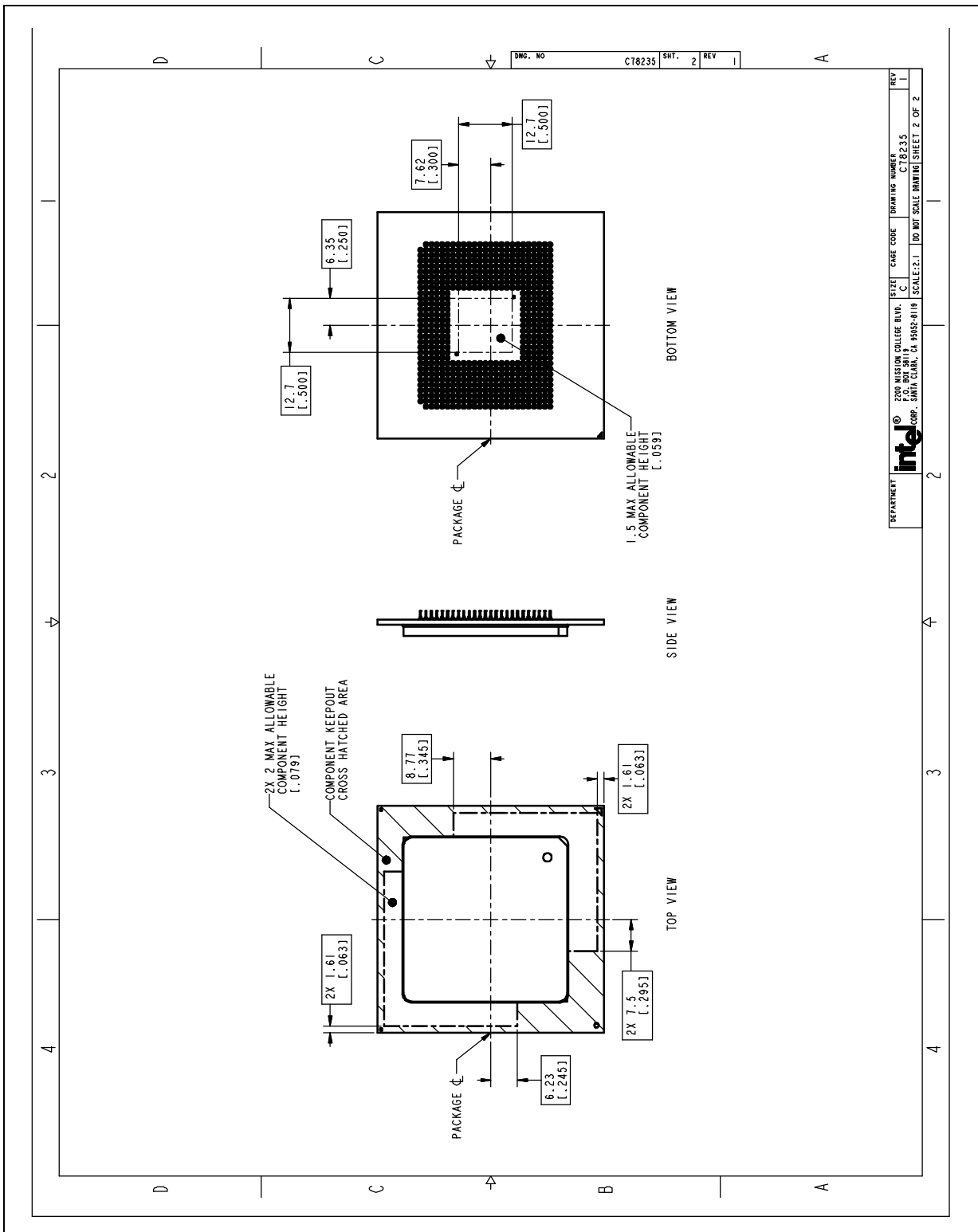

Figure 4-3. Processor Package Drawing (Sheet 2 of 2)



4.2 Processor Component Keepout Zones

The processor may contain components on the substrate that define component keepout zone requirements. A thermal and mechanical solution design must not intrude into the required keepout zones. Decoupling capacitors are typically mounted to either the topside or pin-side of the package substrate. See [Figure 4-2](#) and [Figure 4-3](#) for keepout zones.

4.3 Package Loading Specifications

[Table 4-1](#) provides dynamic and static load specifications for the processor package. These mechanical load limits should not be exceeded during heatsink assembly, shipping conditions, or standard use condition. Also, any mechanical system or component testing should not exceed the maximum limits. No mechanical load should be applied on the substrate for thermal solution. The minimum loading specification must be maintained by any thermal and mechanical solution.

Table 4-1. Processor Loading Specifications

Parameter	Minimum	Maximum	Unit	Notes
Static Compressive Load	44 10	222 50	N lbf	1, 2, 3, 4
	44 10	288 65	N lbf	1, 2, 3, 5
Dynamic Compressive Load		222 N + 0.45 kg * 100 G 50 lbf (static) + 1 lbm * 100 G	N lbf	1, 3, 4, 6, 7
		288 N + 0.45 kg * 100 G 65 lbf (static) + 1 lbm * 100 G	N lbf	1, 3, 5, 6, 7
Transient		445 100	N lbf	1, 3, 8

NOTES:

- These specifications apply to uniform compressive loading in a direction perpendicular to the IHS top surface.
- This is the minimum and maximum static force that can be applied by the heatsink and retention solution to maintain the heatsink and processor interface.
- These parameters are based on limited testing for design characterization. Loading limits are for the package only and do not include the limits of the processor socket.
- This specification applies for thermal retention solutions that allow baseboard deflection.
- This specification applies either for thermal retention solutions that prevent baseboard deflection or for the Intel enabled reference solution (CEK).
- Dynamic loading is defined as an 11 ms duration average load superimposed on the static load requirement.
- Experimentally validated test condition used a heatsink mass of 1 lbm (~0.45 kg) with 100 G acceleration measured at heatsink mass. The dynamic portion of this specification in the product application can have flexibility in specific values, but the ultimate product of mass times acceleration should not exceed this validated dynamic load (1 lbm x 100 G = 100 lb).
- Transient loading is defined as a 2 second duration peak load superimposed on the static load requirement, representative of loads experienced by the package during heatsink installation.

4.4 Package Handling Guidelines

Table 4-2 includes a list of guidelines on package handling in terms of recommended maximum loading on the processor IHS relative to a fixed substrate. These package handling loads may be experienced during heatsink removal.

Table 4-2. Package Handling Guidelines

Parameter	Maximum Recommended	Notes
Shear	356 N [80 lbf]	1, 2
Tensile	156 N [35 lbf]	2, 3
Torque	8 N-m [70 lbf-in]	2, 4

NOTES:

1. A shear load is defined as a load applied to the IHS in a direction parallel to the IHS top surface.
2. These guidelines are based on limited testing for design characterization.
3. A tensile load is defined as a pulling load applied to the IHS in the direction normal to the IHS surface.
4. A torque load is defined as a twisting load applied to the IHS in an axis of rotation normal to the IHS top surface.

4.5 Package Insertion Specifications

The 64-bit Intel® Xeon™ processor MP with 1MB L2 cache can be inserted into and removed from a mPGA604 socket 15 times. The socket should meet the mPGA604 requirements detailed in the *mPGA604 Socket Design Guidelines*.

4.6 Processor Mass Specifications

The typical mass of the 64-bit Intel® Xeon™ processor MP with 1MB L2 cache is 29 g [1.02 oz]. This mass [weight] includes all the components that are included in the package.

4.7 Processor Materials

Table 4-3 lists some of the package components and associated materials.

Table 4-3. Processor Materials

Component	Material
Integrated Heat Spreader (IHS)	Nickel Plated Copper
Substrate	Fiber-Reinforced Resin
Substrate Pins	Gold Plated Copper

4.8 Processor Markings

Figure 4-4 shows the topside markings and Figure 4-5 shows the bottom-side markings on the processor. These diagrams are to aid in the identification of the 64-bit Intel® Xeon™ processor MP with 1MB L2 cache.

Figure 4-4. Processor Topside Markings

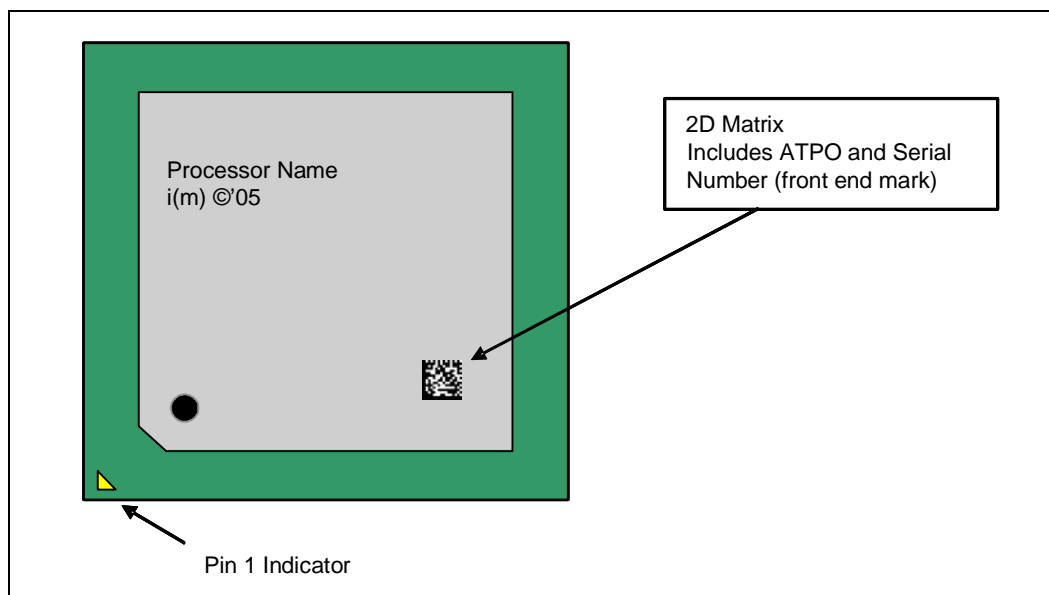

NOTES:

1. All characters will be in upper case

Figure 4-5. Processor Bottom-Side Markings

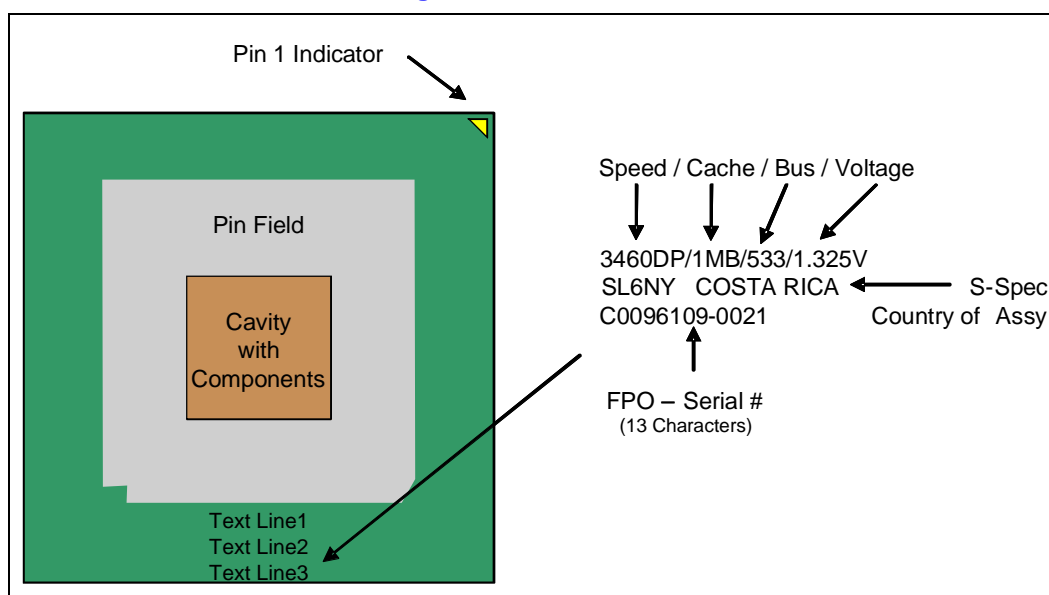

4.9 Processor Pin-Out Coordinates

Figure 4-6 shows the top view of the processor pin coordinates. The coordinates are referred to throughout the document to identify processor pins.

Figure 4-6. Processor Pin-Out Coordinates, Top View

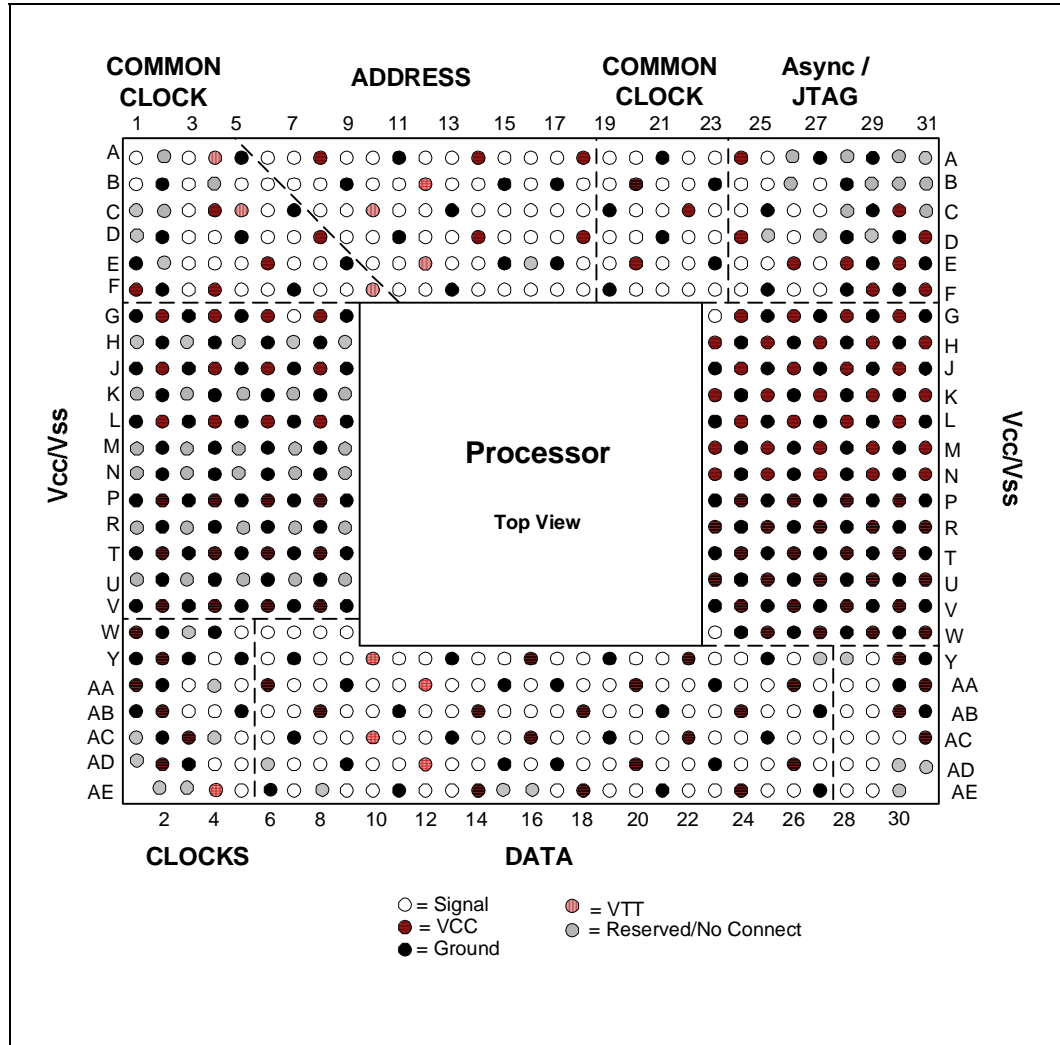





5 Pin Listing

5.1 64-bit Intel® Xeon™ Processor MP with 1MB L2 Cache Pin Assignments

Section 2.5 contains the front side bus signal groups for the 64-bit Intel® Xeon™ processor MP with 1MB L2 cache (see Table 2-4). This section provides a sorted pin list in Table 5-1 and Table 5-2. Table 5-1 is a listing of all processor pins ordered alphabetically by pin name. Table 5-2 is a listing of all processor pins ordered by pin number.

5.1.1 Pin Listing by Pin Name

Table 5-1. Pin Listing by Pin Name

Pin Name	Pin No.	Signal Buffer Type	Direction
A3#	A22	Source Sync	Input/Output
A4#	A20	Source Sync	Input/Output
A5#	B18	Source Sync	Input/Output
A6#	C18	Source Sync	Input/Output
A7#	A19	Source Sync	Input/Output
A8#	C17	Source Sync	Input/Output
A9#	D17	Source Sync	Input/Output
A10#	A13	Source Sync	Input/Output
A11#	B16	Source Sync	Input/Output
A12#	B14	Source Sync	Input/Output
A13#	B13	Source Sync	Input/Output
A14#	A12	Source Sync	Input/Output
A15#	C15	Source Sync	Input/Output
A16#	C14	Source Sync	Input/Output
A17#	D16	Source Sync	Input/Output
A18#	D15	Source Sync	Input/Output
A19#	F15	Source Sync	Input/Output
A20#	A10	Source Sync	Input/Output
A21#	B10	Source Sync	Input/Output
A22#	B11	Source Sync	Input/Output
A23#	C12	Source Sync	Input/Output
A24#	E14	Source Sync	Input/Output
A25#	D13	Source Sync	Input/Output
A26#	A9	Source Sync	Input/Output

Table 5-1. Pin Listing by Pin Name (cont'd)

Pin Name	Pin No.	Signal Buffer Type	Direction
A27#	B8	Source Sync	Input/Output
A28#	E13	Source Sync	Input/Output
A29#	D12	Source Sync	Input/Output
A30#	C11	Source Sync	Input/Output
A31#	B7	Source Sync	Input/Output
A32#	A6	Source Sync	Input/Output
A33#	A7	Source Sync	Input/Output
A34#	C9	Source Sync	Input/Output
A35#	C8	Source Sync	Source Sync
A36#	F16	Source Sync	Source Sync
A37#	F22	Source Sync	Source Sync
A38#	B6	Source Sync	Source Sync
A39#	C16	Source Sync	Source Sync
A20M#	F27	Async GTL+	Input
ADS#	D19	Common Clk	Input/Output
ADSTB0#	F17	Source Sync	Input/Output
ADSTB1#	F14	Source Sync	Input/Output
AP0#	E10	Common Clk	Input/Output
AP1#	D9	Common Clk	Input/Output
BCLK0	Y4	FSB Clk	Input
BCLK1	W5	FSB Clk	Input
BINIT#	F11	Common Clk	Input/Output
BNR#	F20	Common Clk	Input/Output
BOOT_SELECT	G7	Power/Other	Input

Table 5-1. Pin Listing by Pin Name (cont'd)

Pin Name	Pin No.	Signal Buffer Type	Direction
BPM0#	F6	Common Clk	Input/Output
BPM1#	F8	Common Clk	Input/Output
BPM2#	E7	Common Clk	Input/Output
BPM3#	F5	Common Clk	Input/Output
BPM4#	E8	Common Clk	Input/Output
BPM5#	E4	Common Clk	Input/Output
BPRI#	D23	Common Clk	Input
BR0#	D20	Common Clk	Input/Output
BR1#	F12	Common Clk	Input
BR2#	E11	Common Clk	Input
BR3#	D10	Common Clk	Input
BSEL0	AA3	Power/Other	Output
BSEL1	AB3	Power/Other	Output
COMP0	AD16	Power/Other	Input
D0#	Y26	Source Sync	Input/Output
D1#	AA27	Source Sync	Input/Output
D2#	Y24	Source Sync	Input/Output
D3#	AA25	Source Sync	Input/Output
D4#	AD27	Source Sync	Input/Output
D5#	Y23	Source Sync	Input/Output
D6#	AA24	Source Sync	Input/Output
D7#	AB26	Source Sync	Input/Output
D8#	AB25	Source Sync	Input/Output
D9#	AB23	Source Sync	Input/Output
D10#	AA22	Source Sync	Input/Output
D11#	AA21	Source Sync	Input/Output
D12#	AB20	Source Sync	Input/Output
D13#	AB22	Source Sync	Input/Output
D14#	AB19	Source Sync	Input/Output
D15#	AA19	Source Sync	Input/Output
D16#	AE26	Source Sync	Input/Output
D17#	AC26	Source Sync	Input/Output
D18#	AD25	Source Sync	Input/Output
D19#	AE25	Source Sync	Input/Output
D20#	AC24	Source Sync	Input/Output
D21#	AD24	Source Sync	Input/Output
D22#	AE23	Source Sync	Input/Output

Table 5-1. Pin Listing by Pin Name (cont'd)

Pin Name	Pin No.	Signal Buffer Type	Direction
D23#	AC23	Source Sync	Input/Output
D24#	AA18	Source Sync	Input/Output
D25#	AC20	Source Sync	Input/Output
D26#	AC21	Source Sync	Input/Output
D27#	AE22	Source Sync	Input/Output
D28#	AE20	Source Sync	Input/Output
D29#	AD21	Source Sync	Input/Output
D30#	AD19	Source Sync	Input/Output
D31#	AB17	Source Sync	Input/Output
D32#	AB16	Source Sync	Input/Output
D33#	AA16	Source Sync	Input/Output
D34#	AC17	Source Sync	Input/Output
D35#	AE13	Source Sync	Input/Output
D36#	AD18	Source Sync	Input/Output
D37#	AB15	Source Sync	Input/Output
D38#	AD13	Source Sync	Input/Output
D39#	AD14	Source Sync	Input/Output
D40#	AD11	Source Sync	Input/Output
D41#	AC12	Source Sync	Input/Output
D42#	AE10	Source Sync	Input/Output
D43#	AC11	Source Sync	Input/Output
D44#	AE9	Source Sync	Input/Output
D45#	AD10	Source Sync	Input/Output
D46#	AD8	Source Sync	Input/Output
D47#	AC9	Source Sync	Input/Output
D48#	AA13	Source Sync	Input/Output
D49#	AA14	Source Sync	Input/Output
D50#	AC14	Source Sync	Input/Output
D51#	AB12	Source Sync	Input/Output
D52#	AB13	Source Sync	Input/Output
D53#	AA11	Source Sync	Input/Output
D54#	AA10	Source Sync	Input/Output
D55#	AB10	Source Sync	Input/Output
D56#	AC8	Source Sync	Input/Output
D57#	AD7	Source Sync	Input/Output
D58#	AE7	Source Sync	Input/Output
D59#	AC6	Source Sync	Input/Output

Table 5-1. Pin Listing by Pin Name (cont'd)

Pin Name	Pin No.	Signal Buffer Type	Direction
D60#	AC5	Source Sync	Input/Output
D61#	AA8	Source Sync	Input/Output
D62#	Y9	Source Sync	Input/Output
D63#	AB6	Source Sync	Input/Output
DBI0#	AC27	Source Sync	Input/Output
DBI1#	AD22	Source Sync	Input/Output
DBI2#	AE12	Source Sync	Input/Output
DBI3#	AB9	Source Sync	Input/Output
DBSY#	F18	Common Clk	Input/Output
DEFER#	C23	Common Clk	Input
Don't Care	A2		
Don't Care	A26		
Don't Care	A28		
Don't Care	A30		
Don't Care	A31		
Don't Care	B4		
Don't Care	B26		
Don't Care	B29		
Don't Care	B30		
Don't Care	B31		
Don't Care	C2		
Don't Care	C28		
Don't Care	C31		
Don't Care	D1		
Don't Care	D25		
Don't Care	D27		
Don't Care	D29		
Don't Care	E2		
Don't Care	H1		
Don't Care	H3		
Don't Care	H5		
Don't Care	H7		
Don't Care	H9		
Don't Care	K1		
Don't Care	K3		
Don't Care	K5		
Don't Care	K7		

Table 5-1. Pin Listing by Pin Name (cont'd)

Pin Name	Pin No.	Signal Buffer Type	Direction
Don't Care	K9		
Don't Care	M1		
Don't Care	M3		
Don't Care	M5		
Don't Care	M7		
Don't Care	M9		
Don't Care	N1		
Don't Care	N3		
Don't Care	N5		
Don't Care	N7		
Don't Care	N9		
Don't Care	R1		
Don't Care	R3		
Don't Care	R5		
Don't Care	R7		
Don't Care	R9		
Don't Care	U1		
Don't Care	U3		
Don't Care	U5		
Don't Care	U7		
Don't Care	U9		
Don't Care	AA4		
Don't Care	AC4		
Don't Care	AD6		
Don't Care	AD30		
Don't Care	AD31		
Don't Care	AE2		
Don't Care	AE3		
Don't Care	AE8		
Don't Care	AE15		
Don't Care	AE16		
DP0#	AC18	Common Clk	Input/Output
DP1#	AE19	Common Clk	Input/Output
DP2#	AC15	Common Clk	Input/Output
DP3#	AE17	Common Clk	Input/Output
DRDY#	E18	Common Clk	Input/Output
DSTBN0#	Y21	Source Sync	Input/Output

Table 5-1. Pin Listing by Pin Name (cont'd)

Pin Name	Pin No.	Signal Buffer Type	Direction
DSTBN1#	Y18	Source Sync	Input/Output
DSTBN2#	Y15	Source Sync	Input/Output
DSTBN3#	Y12	Source Sync	Input/Output
DSTBP0#	Y20	Source Sync	Input/Output
DSTBP1#	Y17	Source Sync	Input/Output
DSTBP2#	Y14	Source Sync	Input/Output
DSTBP3#	Y11	Source Sync	Input/Output
FERR#/PBE#	E27	Async GTL+	Output
FORCEPR#	A15	Async GTL+	Input
GTLREF0	W23	Power/Other	Input
GTLREF1	W9	Power/Other	Input
GTLREF2	F23	Power/Other	Input
GTLREF3	F9	Power/Other	Input
HIT#	E22	Common Clk	Input/Output
HITM#	A23	Common Clk	Input/Output
IERR#	E5	Async GTL+	Output
IGNNE#	C26	Async GTL+	Input
INIT#	D6	Async GTL+	Input
LINT0/INTR	B24	Async GTL+	Input
LINT1/NMI	G23	Async GTL+	Input
LOCK#	A17	Common Clk	Input/Output
MCERR#	D7	Common Clk	Input/Output
ODTEN	B5	Power/Other	Input
PROCHOT#	B25	Async GTL+	Output
PROCTYPE	Y31	Power/Other	O
PWRGOOD	AB7	Async GTL+	Input
REQ0#	B19	Source Sync	Input/Output
REQ1#	B21	Source Sync	Input/Output
REQ2#	C21	Source Sync	Input/Output
REQ3#	C20	Source Sync	Input/Output
REQ4#	B22	Source Sync	Input/Output
Reserved	C1		
Reserved	E16		
Reserved	W3		
Reserved	Y27		
Reserved	Y28		
Reserved	AC1		

Table 5-1. Pin Listing by Pin Name (cont'd)

Pin Name	Pin No.	Signal Buffer Type	Direction
Reserved	AE30		
RESET#	Y8	Common Clk	Input
RS0#	E21	Common Clk	Input
RS1#	D22	Common Clk	Input
RS2#	F21	Common Clk	Input
RSP#	C6	Common Clk	Input
SKTOCC#	A3	Power/Other	Output
SLEWCTRL	AC30	Power/Other	Input
SM_ALERT#	AD28	SMBus	Output
SM_CLK	AC28	SMBus	Input
SM_DAT	AC29	SMBus	Input/Output
SM_EP_A0	AA29	SMBus	Input
SM_EP_A1	AB29	SMBus	Input
SM_EP_A2	AB28	SMBus	Input
SM_TS1_A0	AA28	SMBus	Input
SM_TS1_A1	Y29	SMBus	Input
SM_VCC	AE28	Power/Other	
SM_VCC	AE29	Power/Other	
SM_WP	AD29	SMBus	Input
SMI#	C27	Async GTL+	Input
STPCLK#	D4	Async GTL+	Input
TCK	E24	TAP	Input
TDI	C24	TAP	Input
TDO	E25	TAP	Output
TEST_BUS	A16	Power/Other	Input
TESTHI0	W6	Power/Other	Input
TESTHI1	W7	Power/Other	Input
TESTHI2	W8	Power/Other	Input
TESTHI3	Y6	Power/Other	Input
TESTHI4	AA7	Power/Other	Input
TESTHI5	AD5	Power/Other	Input
TESTHI6	AE5	Power/Other	Input
THERMTRIP#	F26	Async GTL+	Output
TMS	A25	TAP	Input
TRDY#	E19	Common Clk	Input
TRST#	F24	TAP	Input
V _{CC}	A8	Power/Other	

Table 5-1. Pin Listing by Pin Name (cont'd)

Pin Name	Pin No.	Signal Buffer Type	Direction
V _{CC}	A14	Power/Other	
V _{CC}	A18	Power/Other	
V _{CC}	A24	Power/Other	
V _{CC}	B20	Power/Other	
V _{CC}	C4	Power/Other	
V _{CC}	C22	Power/Other	
V _{CC}	C30	Power/Other	
V _{CC}	D8	Power/Other	
V _{CC}	D14	Power/Other	
V _{CC}	D18	Power/Other	
V _{CC}	D24	Power/Other	
V _{CC}	D31	Power/Other	
V _{CC}	E6	Power/Other	
V _{CC}	E20	Power/Other	
V _{CC}	E26	Power/Other	
V _{CC}	E28	Power/Other	
V _{CC}	E30	Power/Other	
V _{CC}	F1	Power/Other	
V _{CC}	F4	Power/Other	
V _{CC}	F29	Power/Other	
V _{CC}	F31	Power/Other	
V _{CC}	G2	Power/Other	
V _{CC}	G4	Power/Other	
V _{CC}	G6	Power/Other	
V _{CC}	G8	Power/Other	
V _{CC}	G24	Power/Other	
V _{CC}	G26	Power/Other	
V _{CC}	G28	Power/Other	
V _{CC}	G30	Power/Other	
V _{CC}	H23	Power/Other	
V _{CC}	H25	Power/Other	
V _{CC}	H27	Power/Other	
V _{CC}	H29	Power/Other	
V _{CC}	H31	Power/Other	
V _{CC}	J2	Power/Other	
V _{CC}	J4	Power/Other	
V _{CC}	J6	Power/Other	

Table 5-1. Pin Listing by Pin Name (cont'd)

Pin Name	Pin No.	Signal Buffer Type	Direction
V _{CC}	J8	Power/Other	
V _{CC}	J24	Power/Other	
V _{CC}	J26	Power/Other	
V _{CC}	J28	Power/Other	
V _{CC}	J30	Power/Other	
V _{CC}	K23	Power/Other	
V _{CC}	K25	Power/Other	
V _{CC}	K27	Power/Other	
V _{CC}	K29	Power/Other	
V _{CC}	K31	Power/Other	
V _{CC}	L2	Power/Other	
V _{CC}	L4	Power/Other	
V _{CC}	L6	Power/Other	
V _{CC}	L8	Power/Other	
V _{CC}	L24	Power/Other	
V _{CC}	L26	Power/Other	
V _{CC}	L28	Power/Other	
V _{CC}	L30	Power/Other	
V _{CC}	M23	Power/Other	
V _{CC}	M25	Power/Other	
V _{CC}	M27	Power/Other	
V _{CC}	M29	Power/Other	
V _{CC}	M31	Power/Other	
V _{CC}	N23	Power/Other	
V _{CC}	N25	Power/Other	
V _{CC}	N27	Power/Other	
V _{CC}	N29	Power/Other	
V _{CC}	N31	Power/Other	
V _{CC}	P2	Power/Other	
V _{CC}	P4	Power/Other	
V _{CC}	P6	Power/Other	
V _{CC}	P8	Power/Other	
V _{CC}	P24	Power/Other	
V _{CC}	P26	Power/Other	
V _{CC}	P28	Power/Other	
V _{CC}	P30	Power/Other	
V _{CC}	R23	Power/Other	

Table 5-1. Pin Listing by Pin Name (cont'd)

Pin Name	Pin No.	Signal Buffer Type	Direction
V _{CC}	R25	Power/Other	
V _{CC}	R27	Power/Other	
V _{CC}	R29	Power/Other	
V _{CC}	R31	Power/Other	
V _{CC}	T2	Power/Other	
V _{CC}	T4	Power/Other	
V _{CC}	T6	Power/Other	
V _{CC}	T8	Power/Other	
V _{CC}	T24	Power/Other	
V _{CC}	T26	Power/Other	
V _{CC}	T28	Power/Other	
V _{CC}	T30	Power/Other	
V _{CC}	U23	Power/Other	
V _{CC}	U25	Power/Other	
V _{CC}	U27	Power/Other	
V _{CC}	U29	Power/Other	
V _{CC}	U31	Power/Other	
V _{CC}	V2	Power/Other	
V _{CC}	V4	Power/Other	
V _{CC}	V6	Power/Other	
V _{CC}	V8	Power/Other	
V _{CC}	V24	Power/Other	
V _{CC}	V26	Power/Other	
V _{CC}	V28	Power/Other	
V _{CC}	V30	Power/Other	
V _{CC}	W1	Power/Other	
V _{CC}	W25	Power/Other	
V _{CC}	W27	Power/Other	
V _{CC}	W29	Power/Other	
V _{CC}	W31	Power/Other	
V _{CC}	Y2	Power/Other	
V _{CC}	Y16	Power/Other	
V _{CC}	Y22	Power/Other	
V _{CC}	Y30	Power/Other	
V _{CC}	AA1	Power/Other	
V _{CC}	AA6	Power/Other	
V _{CC}	AA20	Power/Other	

Table 5-1. Pin Listing by Pin Name (cont'd)

Pin Name	Pin No.	Signal Buffer Type	Direction
V _{CC}	AA26	Power/Other	
V _{CC}	AA31	Power/Other	
V _{CC}	AB2	Power/Other	
V _{CC}	AB8	Power/Other	
V _{CC}	AB14	Power/Other	
V _{CC}	AB18	Power/Other	
V _{CC}	AB24	Power/Other	
V _{CC}	AB30	Power/Other	
V _{CC}	AC3	Power/Other	
V _{CC}	AC16	Power/Other	
V _{CC}	AC22	Power/Other	
V _{CC}	AC31	Power/Other	
V _{CC}	AD2	Power/Other	
V _{CC}	AD20	Power/Other	
V _{CC}	AD26	Power/Other	
V _{CC}	AE14	Power/Other	
V _{CC}	AE18	Power/Other	
V _{CC}	AE24	Power/Other	
V _{CCA}	AB4	Power/Other	Input
V _{CCIOPLL}	AD4	Power/Other	Input
V _{CCSENSE}	B27	Power/Other	Output
VID0	F3	Power/Other	Output
VID1	E3	Power/Other	Output
VID2	D3	Power/Other	Output
VID3	C3	Power/Other	Output
VID4	B3	Power/Other	Output
VID5	A1	Power/Other	Output
VIDPWRGD	B1	Power/Other	Input
V _{SS}	A5	Power/Other	
V _{SS}	A11	Power/Other	
V _{SS}	A21	Power/Other	
V _{SS}	A27	Power/Other	
V _{SS}	A29	Power/Other	
V _{SS}	B2	Power/Other	
V _{SS}	B9	Power/Other	
V _{SS}	B15	Power/Other	
V _{SS}	B17	Power/Other	

Table 5-1. Pin Listing by Pin Name (cont'd)

Pin Name	Pin No.	Signal Buffer Type	Direction
V _{SS}	B23	Power/Other	
V _{SS}	B28	Power/Other	
V _{SS}	C7	Power/Other	
V _{SS}	C13	Power/Other	
V _{SS}	C19	Power/Other	
V _{SS}	C25	Power/Other	
V _{SS}	C29	Power/Other	
V _{SS}	D2	Power/Other	
V _{SS}	D5	Power/Other	
V _{SS}	D11	Power/Other	
V _{SS}	D21	Power/Other	
V _{SS}	D28	Power/Other	
V _{SS}	D30	Power/Other	
V _{SS}	E9	Power/Other	
V _{SS}	E15	Power/Other	
V _{SS}	E17	Power/Other	
V _{SS}	E23	Power/Other	
V _{SS}	E29	Power/Other	
V _{SS}	E31	Power/Other	
V _{SS}	F2	Power/Other	
V _{SS}	F7	Power/Other	
V _{SS}	F13	Power/Other	
V _{SS}	F19	Power/Other	
V _{SS}	F25	Power/Other	
V _{SS}	F28	Power/Other	
V _{SS}	F30	Power/Other	
V _{SS}	G1	Power/Other	
V _{SS}	G3	Power/Other	
V _{SS}	G5	Power/Other	
V _{SS}	G9	Power/Other	
V _{SS}	G25	Power/Other	
V _{SS}	G27	Power/Other	
V _{SS}	G29	Power/Other	
V _{SS}	G31	Power/Other	
V _{SS}	H2	Power/Other	
V _{SS}	H4	Power/Other	
V _{SS}	H6	Power/Other	

Table 5-1. Pin Listing by Pin Name (cont'd)

Pin Name	Pin No.	Signal Buffer Type	Direction
V _{SS}	H8	Power/Other	
V _{SS}	H24	Power/Other	
V _{SS}	H26	Power/Other	
V _{SS}	H28	Power/Other	
V _{SS}	H30	Power/Other	
V _{SS}	J1	Power/Other	
V _{SS}	J3	Power/Other	
V _{SS}	J5	Power/Other	
V _{SS}	J7	Power/Other	
V _{SS}	J9	Power/Other	
V _{SS}	J23	Power/Other	
V _{SS}	J25	Power/Other	
V _{SS}	J27	Power/Other	
V _{SS}	J29	Power/Other	
V _{SS}	J31	Power/Other	
V _{SS}	K2	Power/Other	
V _{SS}	K4	Power/Other	
V _{SS}	K6	Power/Other	
V _{SS}	K8	Power/Other	
V _{SS}	K24	Power/Other	
V _{SS}	K26	Power/Other	
V _{SS}	K28	Power/Other	
V _{SS}	K30	Power/Other	
V _{SS}	L1	Power/Other	
V _{SS}	L3	Power/Other	
V _{SS}	L5	Power/Other	
V _{SS}	L7	Power/Other	
V _{SS}	L9	Power/Other	
V _{SS}	L23	Power/Other	
V _{SS}	L25	Power/Other	
V _{SS}	L27	Power/Other	
V _{SS}	L29	Power/Other	
V _{SS}	L31	Power/Other	
V _{SS}	M2	Power/Other	
V _{SS}	M4	Power/Other	
V _{SS}	M6	Power/Other	
V _{SS}	M8	Power/Other	

Table 5-1. Pin Listing by Pin Name (cont'd)

Pin Name	Pin No.	Signal Buffer Type	Direction
V _{SS}	M24	Power/Other	
V _{SS}	M26	Power/Other	
V _{SS}	M28	Power/Other	
V _{SS}	M30	Power/Other	
V _{SS}	N2	Power/Other	
V _{SS}	N4	Power/Other	
V _{SS}	N6	Power/Other	
V _{SS}	N8	Power/Other	
V _{SS}	N24	Power/Other	
V _{SS}	N26	Power/Other	
V _{SS}	N28	Power/Other	
V _{SS}	N30	Power/Other	
V _{SS}	P1	Power/Other	
V _{SS}	P3	Power/Other	
V _{SS}	P5	Power/Other	
V _{SS}	P7	Power/Other	
V _{SS}	P9	Power/Other	
V _{SS}	P23	Power/Other	
V _{SS}	P25	Power/Other	
V _{SS}	P27	Power/Other	
V _{SS}	P29	Power/Other	
V _{SS}	P31	Power/Other	
V _{SS}	R2	Power/Other	
V _{SS}	R4	Power/Other	
V _{SS}	R6	Power/Other	
V _{SS}	R8	Power/Other	
V _{SS}	R24	Power/Other	
V _{SS}	R26	Power/Other	
V _{SS}	R28	Power/Other	
V _{SS}	R30	Power/Other	
V _{SS}	T1	Power/Other	
V _{SS}	T3	Power/Other	
V _{SS}	T5	Power/Other	
V _{SS}	T7	Power/Other	
V _{SS}	T9	Power/Other	
V _{SS}	T23	Power/Other	
V _{SS}	T25	Power/Other	

Table 5-1. Pin Listing by Pin Name (cont'd)

Pin Name	Pin No.	Signal Buffer Type	Direction
V _{SS}	T27	Power/Other	
V _{SS}	T29	Power/Other	
V _{SS}	T31	Power/Other	
V _{SS}	U2	Power/Other	
V _{SS}	U4	Power/Other	
V _{SS}	U6	Power/Other	
V _{SS}	U8	Power/Other	
V _{SS}	U24	Power/Other	
V _{SS}	U26	Power/Other	
V _{SS}	U28	Power/Other	
V _{SS}	U30	Power/Other	
V _{SS}	V1	Power/Other	
V _{SS}	V3	Power/Other	
V _{SS}	V5	Power/Other	
V _{SS}	V7	Power/Other	
V _{SS}	V9	Power/Other	
V _{SS}	V23	Power/Other	
V _{SS}	V25	Power/Other	
V _{SS}	V27	Power/Other	
V _{SS}	V29	Power/Other	
V _{SS}	V31	Power/Other	
V _{SS}	W2	Power/Other	
V _{SS}	W4	Power/Other	
V _{SS}	W24	Power/Other	
V _{SS}	W26	Power/Other	
V _{SS}	W28	Power/Other	
V _{SS}	W30	Power/Other	
V _{SS}	Y1	Power/Other	
V _{SS}	Y3	Power/Other	
V _{SS}	Y5	Power/Other	
V _{SS}	Y7	Power/Other	
V _{SS}	Y13	Power/Other	
V _{SS}	Y19	Power/Other	
V _{SS}	Y25	Power/Other	
V _{SS}	AA2	Power/Other	
V _{SS}	AA9	Power/Other	
V _{SS}	AA15	Power/Other	

Table 5-1. Pin Listing by Pin Name (cont'd)

Pin Name	Pin No.	Signal Buffer Type	Direction
V _{SS}	AA17	Power/Other	
V _{SS}	AA23	Power/Other	
V _{SS}	AA30	Power/Other	
V _{SS}	AB1	Power/Other	
V _{SS}	AB5	Power/Other	
V _{SS}	AB11	Power/Other	
V _{SS}	AB21	Power/Other	
V _{SS}	AB27	Power/Other	
V _{SS}	AB31	Power/Other	
V _{SS}	AC2	Power/Other	
V _{SS}	AC7	Power/Other	
V _{SS}	AC13	Power/Other	
V _{SS}	AC19	Power/Other	
V _{SS}	AC25	Power/Other	
V _{SS}	AD3	Power/Other	
V _{SS}	AD9	Power/Other	
V _{SS}	AD15	Power/Other	
V _{SS}	AD17	Power/Other	
V _{SS}	AD23	Power/Other	
V _{SS}	AE6	Power/Other	
V _{SS}	AE11	Power/Other	
V _{SS}	AE21	Power/Other	
V _{SS}	AE27	Power/Other	

Table 5-1. Pin Listing by Pin Name (cont'd)

Pin Name	Pin No.	Signal Buffer Type	Direction
V _{SSA}	AA5	Power/Other	Input
V _{SSSENSE}	D26	Power/Other	Output
V _{TT}	A4	Power/Other	
V _{TT}	B12	Power/Other	
V _{TT}	C5	Power/Other	
V _{TT}	C10	Power/Other	
V _{TT}	E12	Power/Other	
V _{TT}	F10	Power/Other	
V _{TT}	Y10	Power/Other	
V _{TT}	AA12	Power/Other	
V _{TT}	AC10	Power/Other	
V _{TT}	AD12	Power/Other	
V _{TT}	AE4	Power/Other	
V _{TTEN}	E1	Power/Other	Output

5.1.2 Pin Listing by Pin Number

Table 5-2. Pin Listing by Pin Number

Pin No.	Pin Name	Signal Buffer Type	Direction
A1	VID5	Power/Other	Output
A2	Don't Care		
A3	SKTOCC#	Power/Other	Output
A4	V _{TT}	Power/Other	
A5	V _{SS}	Power/Other	
A6	A32#	Source Sync	Input/Output
A7	A33#	Source Sync	Input/Output
A8	V _{CC}	Power/Other	
A9	A26#	Source Sync	Input/Output
A10	A20#	Source Sync	Input/Output
A11	V _{SS}	Power/Other	
A12	A14#	Source Sync	Input/Output
A13	A10#	Source Sync	Input/Output
A14	V _{CC}	Power/Other	
A15	FORCEPR#	Async GTL+	Input
A16	TEST_BUS	Power/Other	Input
A17	LOCK#	Common Clk	Input/Output
A18	V _{CC}	Power/Other	
A19	A7#	Source Sync	Input/Output
A20	A4#	Source Sync	Input/Output
A21	V _{SS}	Power/Other	
A22	A3#	Source Sync	Input/Output
A23	HITM#	Common Clk	Input/Output
A24	V _{CC}	Power/Other	
A25	TMS	TAP	Input
A26	Don't Care		
A27	V _{SS}	Power/Other	
A28	Don't Care		
A29	V _{SS}	Power/Other	
A30	Don't Care		
A31	Don't Care		
B1	VIDPWRGD	Power/Other	Input
B2	V _{SS}	Power/Other	
B3	VID4	Power/Other	Output
B4	Don't Care		
B5	ODTEN	Power/Other	Input

Table 5-2. Pin Listing by Pin Number (cont'd)

Pin No.	Pin Name	Signal Buffer Type	Direction
B6	A38#	Source Sync	Input/Output
B7	A31#	Source Sync	Input/Output
B8	A27#	Source Sync	Input/Output
B9	V _{SS}	Power/Other	
B10	A21#	Source Sync	Input/Output
B11	A22#	Source Sync	Input/Output
B12	V _{TT}	Power/Other	
B13	A13#	Source Sync	Input/Output
B14	A12#	Source Sync	Input/Output
B15	V _{SS}	Power/Other	
B16	A11#	Source Sync	Input/Output
B17	V _{SS}	Power/Other	
B18	A5#	Source Sync	Input/Output
B19	REQ0#	Common Clk	Input/Output
B20	V _{CC}	Power/Other	
B21	REQ1#	Common Clk	Input/Output
B22	REQ4#	Common Clk	Input/Output
B23	V _{SS}	Power/Other	
B24	LINT0/INTR	Async GTL+	Input
B25	PROCHOT#	Async GTL+	Output
B26	Don't Care		
B27	V _{CC} SENSE	Power/Other	Output
B28	V _{SS}	Power/Other	
B29	Don't Care		
B30	Don't Care		
B31	Don't Care		
C1	Reserved		
C2	Don't Care		
C3	VID3	Power/Other	Output
C4	V _{CC}	Power/Other	
C5	V _{TT}	Power/Other	
C6	RSP#	Common Clk	Input
C7	V _{SS}	Power/Other	
C8	A35#	Source Sync	Input/Output
C9	A34#	Source Sync	Input/Output
C10	V _{TT}	Power/Other	

Table 5-2. Pin Listing by Pin Number (cont'd)

Pin No.	Pin Name	Signal Buffer Type	Direction
C11	A30#	Source Sync	Input/Output
C12	A23#	Source Sync	Input/Output
C13	V _{SS}	Power/Other	
C14	A16#	Source Sync	Input/Output
C15	A15#	Source Sync	Input/Output
C16	A39#	Source Sync	Input/Output
C17	A8#	Source Sync	Input/Output
C18	A6#	Source Sync	Input/Output
C19	V _{SS}	Power/Other	
C20	REQ3#	Common Clk	Input/Output
C21	REQ2#	Common Clk	Input/Output
C22	V _{CC}	Power/Other	
C23	DEFER#	Common Clk	Input
C24	TDI	TAP	Input
C25	V _{SS}	Power/Other	Input
C26	IGNNE#	Async GTL+	Input
C27	SMI#	Async GTL+	Input
C28	Don't Care		
C29	V _{SS}	Power/Other	
C30	V _{CC}	Power/Other	
C31	Don't Care		
D1	Don't Care		
D2	V _{SS}	Power/Other	
D3	VID2	Power/Other	Output
D4	STPCLK#	Async GTL+	Input
D5	V _{SS}	Power/Other	
D6	INIT#	Async GTL+	Input
D7	MCERR#	Common Clk	Input/Output
D8	V _{CC}	Power/Other	
D9	AP1#	Common Clk	Input/Output
D10	BR3#	Common Clk	Input
D11	V _{SS}	Power/Other	
D12	A29#	Source Sync	Input/Output
D13	A25#	Source Sync	Input/Output
D14	V _{CC}	Power/Other	
D15	A18#	Source Sync	Input/Output

Table 5-2. Pin Listing by Pin Number (cont'd)

Pin No.	Pin Name	Signal Buffer Type	Direction
D16	A17#	Source Sync	Input/Output
D17	A9#	Source Sync	Input/Output
D18	V _{CC}	Power/Other	
D19	ADS#	Common Clk	Input/Output
D20	BR0#	Common Clk	Input/Output
D21	V _{SS}	Power/Other	
D22	RS1#	Common Clk	Input
D23	BPRI#	Common Clk	Input
D24	V _{CC}	Power/Other	
D25	Don't Care		
D26	V _{SSSENSE}	Power/Other	Output
D27	Don't Care		
D28	V _{SS}	Power/Other	
D29	Don't Care		
D30	V _{SS}	Power/Other	
D31	V _{CC}	Power/Other	
E1	VTTEN	Power/Other	Output
E2	Don't Care		
E3	VID1	Power/Other	Output
E4	BPM5#	Common Clk	Input/Output
E5	IERR#	Async GTL+	Output
E6	V _{CC}	Power/Other	
E7	BPM2#	Common Clk	Input/Output
E8	BPM4#	Common Clk	Input/Output
E9	V _{SS}	Power/Other	
E10	AP0#	Common Clk	Input/Output
E11	BR2#	Common Clk	Input
E12	V _{TT}	Power/Other	
E13	A28#	Source Sync	Input/Output
E14	A24#	Source Sync	Input/Output
E15	V _{SS}	Power/Other	
E16	Reserved		
E17	V _{SS}	Power/Other	

Table 5-2. Pin Listing by Pin Number (cont'd)

Pin No.	Pin Name	Signal Buffer Type	Direction
E18	DRDY#	Common Clk	Input/Output
E19	TRDY#	Common Clk	Input
E20	V _{CC}	Power/Other	
E21	RS0#	Common Clk	Input
E22	HIT#	Common Clk	Input/Output
E23	V _{SS}	Power/Other	
E24	TCK	TAP	Input
E25	TDO	TAP	Output
E26	V _{CC}	Power/Other	
E27	FERR#/PBE#	Async GTL+	Output
E28	V _{CC}	Power/Other	
E29	V _{SS}	Power/Other	
E30	V _{CC}	Power/Other	
E31	V _{SS}	Power/Other	
F1	V _{CC}	Power/Other	
F2	V _{SS}	Power/Other	
F3	VID0	Power/Other	Output
F4	V _{CC}	Power/Other	
F5	BPM3#	Common Clk	Input/Output
F6	BPM0#	Common Clk	Input/Output
F7	V _{SS}	Power/Other	
F8	BPM1#	Common Clk	Input/Output
F9	GTLREF3	Power/Other	Input
F10	V _{TT}	Power/Other	
F11	BINIT#	Common Clk	Input/Output
F12	BR1#	Common Clk	Input
F13	V _{SS}	Power/Other	
F14	ADSTB1#	Source Sync	Input/Output
F15	A19#	Source Sync	Input/Output
F16	A36#	Source Sync	Input/Output
F17	ADSTB0#	Source Sync	Input/Output
F18	DBSY#	Common Clk	Input/Output
F19	V _{SS}	Power/Other	

Table 5-2. Pin Listing by Pin Number (cont'd)

Pin No.	Pin Name	Signal Buffer Type	Direction
F20	BNR#	Common Clk	Input/Output
F21	RS2#	Common Clk	Input
F22	A37#	Source Sync	Input/Output
F23	GTLREF2	Power/Other	Input
F24	TRST#	TAP	Input
F25	V _{SS}	Power/Other	
F26	THERMTRIP#	Async GTL+	Output
F27	A20M#	Async GTL+	Input
F28	V _{SS}	Power/Other	
F29	V _{CC}	Power/Other	
F30	V _{SS}	Power/Other	
F31	V _{CC}	Power/Other	
G1	V _{SS}	Power/Other	
G2	V _{CC}	Power/Other	
G3	V _{SS}	Power/Other	
G4	V _{CC}	Power/Other	
G5	V _{SS}	Power/Other	
G6	V _{CC}	Power/Other	
G7	BOOT_SELECT	Power/Other	Input
G8	V _{CC}	Power/Other	
G9	V _{SS}	Power/Other	
G23	LINT1/NMI	Async GTL+	Input
G24	V _{CC}	Power/Other	
G25	V _{SS}	Power/Other	
G26	V _{CC}	Power/Other	
G27	V _{SS}	Power/Other	
G28	V _{CC}	Power/Other	
G29	V _{SS}	Power/Other	
G30	V _{CC}	Power/Other	
G31	V _{SS}	Power/Other	
H1	Don't Care		
H2	V _{SS}		
H3	Don't Care		
H4	V _{SS}		
H5	Don't Care		
H6	V _{SS}		
H7	Don't Care		
H8	V _{SS}		

Table 5-2. Pin Listing by Pin Number (cont'd)

Pin No.	Pin Name	Signal Buffer Type	Direction
H9	Don't Care		
H23	V _{CC}	Power/Other	
H24	V _{SS}	Power/Other	
H25	V _{CC}	Power/Other	
H26	V _{SS}	Power/Other	
H27	V _{CC}	Power/Other	
H28	V _{SS}	Power/Other	
H29	V _{CC}	Power/Other	
H30	V _{SS}	Power/Other	
H31	V _{CC}	Power/Other	
J1	V _{SS}	Power/Other	
J2	V _{CC}	Power/Other	
J3	V _{SS}	Power/Other	
J4	V _{CC}	Power/Other	
J5	V _{SS}	Power/Other	
J6	V _{CC}	Power/Other	
J7	V _{SS}	Power/Other	
J8	V _{CC}	Power/Other	
J9	V _{SS}	Power/Other	
J23	V _{SS}	Power/Other	
J24	V _{CC}	Power/Other	
J25	V _{SS}	Power/Other	
J26	V _{CC}	Power/Other	
J27	V _{SS}	Power/Other	
J28	V _{CC}	Power/Other	
J29	V _{SS}	Power/Other	
J30	V _{CC}	Power/Other	
J31	V _{SS}	Power/Other	
K1	Don't Care		
K2	V _{SS}	Power/Other	
K3	Don't Care		
K4	V _{SS}	Power/Other	
K5	Don't Care		
K6	V _{SS}	Power/Other	
K7	Don't Care		
K8	V _{SS}	Power/Other	
K9	Don't Care		
K23	V _{CC}	Power/Other	
K24	V _{SS}	Power/Other	
K25	V _{CC}	Power/Other	

Table 5-2. Pin Listing by Pin Number (cont'd)

Pin No.	Pin Name	Signal Buffer Type	Direction
K26	V _{SS}	Power/Other	
K27	V _{CC}	Power/Other	
K28	V _{SS}	Power/Other	
K29	V _{CC}	Power/Other	
K30	V _{SS}	Power/Other	
K31	V _{CC}	Power/Other	
L1	V _{SS}	Power/Other	
L2	V _{CC}	Power/Other	
L3	V _{SS}	Power/Other	
L4	V _{CC}	Power/Other	
L5	V _{SS}	Power/Other	
L6	V _{CC}	Power/Other	
L7	V _{SS}	Power/Other	
L8	V _{CC}	Power/Other	
L9	V _{SS}	Power/Other	
L23	V _{SS}	Power/Other	
L24	V _{CC}	Power/Other	
L25	V _{SS}	Power/Other	
L26	V _{CC}	Power/Other	
L27	V _{SS}	Power/Other	
L28	V _{CC}	Power/Other	
L29	V _{SS}	Power/Other	
L30	V _{CC}	Power/Other	
L31	V _{SS}	Power/Other	
M1	Don't Care		
M2	V _{SS}	Power/Other	
M3	Don't Care		
M4	V _{SS}	Power/Other	
M5	Don't Care		
M6	V _{SS}	Power/Other	
M7	Don't Care		
M8	V _{SS}	Power/Other	
M9	Don't Care		
M23	V _{CC}	Power/Other	
M24	V _{SS}	Power/Other	
M25	V _{CC}	Power/Other	
M26	V _{SS}	Power/Other	
M27	V _{CC}	Power/Other	
M28	V _{SS}	Power/Other	
M29	V _{CC}	Power/Other	

Table 5-2. Pin Listing by Pin Number (cont'd)

Pin No.	Pin Name	Signal Buffer Type	Direction
M30	V _{SS}	Power/Other	
M31	V _{CC}	Power/Other	
N1	Don't Care		
N2	V _{SS}	Power/Other	
N3	Don't Care		
N4	V _{SS}	Power/Other	
N5	Don't Care		
N6	V _{SS}	Power/Other	
N7	Don't Care		
N8	V _{SS}	Power/Other	
N9	Don't Care		
N23	V _{CC}	Power/Other	
N24	V _{SS}	Power/Other	
N25	V _{CC}	Power/Other	
N26	V _{SS}	Power/Other	
N27	V _{CC}	Power/Other	
N28	V _{SS}	Power/Other	
N29	V _{CC}	Power/Other	
N30	V _{SS}	Power/Other	
N31	V _{CC}	Power/Other	
P1	V _{SS}	Power/Other	
P2	V _{CC}	Power/Other	
P3	V _{SS}	Power/Other	
P4	V _{CC}	Power/Other	
P5	V _{SS}	Power/Other	
P6	V _{CC}	Power/Other	
P7	V _{SS}	Power/Other	
P8	V _{CC}	Power/Other	
P9	V _{SS}	Power/Other	
P23	V _{SS}	Power/Other	
P24	V _{CC}	Power/Other	
P25	V _{SS}	Power/Other	
P26	V _{CC}	Power/Other	
P27	V _{SS}	Power/Other	
P28	V _{CC}	Power/Other	
P29	V _{SS}	Power/Other	
P30	V _{CC}	Power/Other	
P31	V _{SS}	Power/Other	
R1	Don't Care		
R2	V _{SS}	Power/Other	

Table 5-2. Pin Listing by Pin Number (cont'd)

Pin No.	Pin Name	Signal Buffer Type	Direction
R3	Don't Care		
R4	V _{SS}	Power/Other	
R5	Don't Care		
R6	V _{SS}	Power/Other	
R7	Don't Care		
R8	V _{SS}	Power/Other	
R9	Don't Care		
R23	V _{CC}	Power/Other	
R24	V _{SS}	Power/Other	
R25	V _{CC}	Power/Other	
R26	V _{SS}	Power/Other	
R27	V _{CC}	Power/Other	
R28	V _{SS}	Power/Other	
R29	V _{CC}	Power/Other	
R30	V _{SS}	Power/Other	
R31	V _{CC}	Power/Other	
T1	V _{SS}	Power/Other	
T2	V _{CC}	Power/Other	
T3	V _{SS}	Power/Other	
T4	V _{CC}	Power/Other	
T5	V _{SS}	Power/Other	
T6	V _{CC}	Power/Other	
T7	V _{SS}	Power/Other	
T8	V _{CC}	Power/Other	
T9	V _{SS}	Power/Other	
T23	V _{SS}	Power/Other	
T24	V _{CC}	Power/Other	
T25	V _{SS}	Power/Other	
T26	V _{CC}	Power/Other	
T27	V _{SS}	Power/Other	
T28	V _{CC}	Power/Other	
T29	V _{SS}	Power/Other	
T30	V _{CC}	Power/Other	
T31	V _{SS}	Power/Other	
U1	Don't Care		
U2	V _{SS}	Power/Other	
U3	Don't Care		
U4	V _{SS}	Power/Other	
U5	Don't Care		
U6	V _{SS}	Power/Other	

Table 5-2. Pin Listing by Pin Number (cont'd)

Pin No.	Pin Name	Signal Buffer Type	Direction
U7	Don't Care		
U8	V _{SS}	Power/Other	
U9	Don't Care		
U23	V _{CC}	Power/Other	
U24	V _{SS}	Power/Other	
U25	V _{CC}	Power/Other	
U26	V _{SS}	Power/Other	
U27	V _{CC}	Power/Other	
U28	V _{SS}	Power/Other	
U29	V _{CC}	Power/Other	
U30	V _{SS}	Power/Other	
U31	V _{CC}	Power/Other	
V1	V _{SS}	Power/Other	
V2	V _{CC}	Power/Other	
V3	V _{SS}	Power/Other	
V4	V _{CC}	Power/Other	
V5	V _{SS}	Power/Other	
V6	V _{CC}	Power/Other	
V7	V _{SS}	Power/Other	
V8	V _{CC}	Power/Other	
V9	V _{SS}	Power/Other	
V23	V _{SS}	Power/Other	
V24	V _{CC}	Power/Other	
V25	V _{SS}	Power/Other	
V26	V _{CC}	Power/Other	
V27	V _{SS}	Power/Other	
V28	V _{CC}	Power/Other	
V29	V _{SS}	Power/Other	
V30	V _{CC}	Power/Other	
V31	V _{SS}	Power/Other	
W1	V _{CC}	Power/Other	
W2	V _{SS}	Power/Other	
W3	Reserved		
W4	V _{SS}	Power/Other	
W5	BCLK1	FSB Clk	Input
W6	TESTHI0	Power/Other	Input
W7	TESTHI1	Power/Other	Input
W8	TESTHI2	Power/Other	Input
W9	GTLREF1	Power/Other	Input
W23	GTLREF0	Power/Other	Input

Table 5-2. Pin Listing by Pin Number (cont'd)

Pin No.	Pin Name	Signal Buffer Type	Direction
W24	V _{SS}	Power/Other	
W25	V _{CC}	Power/Other	
W26	V _{SS}	Power/Other	
W27	V _{CC}	Power/Other	
W28	V _{SS}	Power/Other	
W29	V _{CC}	Power/Other	
W30	V _{SS}	Power/Other	
W31	V _{CC}	Power/Other	
Y1	V _{SS}	Power/Other	
Y2	V _{CC}	Power/Other	
Y3	V _{SS}	Power/Other	
Y4	BCLK0	FSB Clk	Input
Y5	V _{SS}	Power/Other	
Y6	TESTHI3	Power/Other	Input
Y7	V _{SS}	Power/Other	
Y8	RESET#	Common Clk	Input
Y9	D62#	Source Sync	Input/Output
Y10	V _{TT}	Power/Other	
Y11	DSTBP3#	Source Sync	Input/Output
Y12	DSTBN3#	Source Sync	Input/Output
Y13	V _{SS}	Power/Other	
Y14	DSTBP2#	Source Sync	Input/Output
Y15	DSTBN2#	Source Sync	Input/Output
Y16	V _{CC}	Power/Other	
Y17	DSTBP1#	Source Sync	Input/Output
Y18	DSTBN1#	Source Sync	Input/Output
Y19	V _{SS}	Power/Other	
Y20	DSTBP0#	Source Sync	Input/Output
Y21	DSTBN0#	Source Sync	Input/Output
Y22	V _{CC}	Power/Other	
Y23	D5#	Source Sync	Input/Output
Y24	D2#	Source Sync	Input/Output
Y25	V _{SS}	Power/Other	
Y26	D0#	Source Sync	Input/Output
Y27	Reserved		
Y28	Reserved		
Y29	SM_TS1_A1	SMBus	Input
Y30	V _{CC}	Power/Other	
Y31	PROCTYPE	Power/Other	O

Table 5-2. Pin Listing by Pin Number (cont'd)

Pin No.	Pin Name	Signal Buffer Type	Direction
AA1	V _{CC}	Power/Other	
AA2	V _{SS}	Power/Other	
AA3	BSEL0	Power/Other	Output
AA4	Don't Care		
AA5	V _{SSA}	Power/Other	Input
AA6	V _{CC}	Power/Other	
AA7	TESTHI4	Power/Other	Input
AA8	D61#	Source Sync	Input/Output
AA9	V _{SS}	Power/Other	
AA10	D54#	Source Sync	Input/Output
AA11	D53#	Source Sync	Input/Output
AA12	V _{TT}	Power/Other	
AA13	D48#	Source Sync	Input/Output
AA14	D49#	Source Sync	Input/Output
AA15	V _{SS}	Power/Other	
AA16	D33#	Source Sync	Input/Output
AA17	V _{SS}	Power/Other	
AA18	D24#	Source Sync	Input/Output
AA19	D15#	Source Sync	Input/Output
AA20	V _{CC}	Power/Other	
AA21	D11#	Source Sync	Input/Output
AA22	D10#	Source Sync	Input/Output
AA23	V _{SS}	Power/Other	
AA24	D6#	Source Sync	Input/Output
AA25	D3#	Source Sync	Input/Output
AA26	V _{CC}	Power/Other	
AA27	D1#	Source Sync	Input/Output
AA28	SM_TS1_A0	SMBus	Input
AA29	SM_EP_A0	SMBus	Input
AA30	V _{SS}	Power/Other	
AA31	V _{CC}	Power/Other	
AB1	V _{SS}	Power/Other	
AB2	V _{CC}	Power/Other	
AB3	BSEL1	Power/Other	Output
AB4	V _{CCA}	Power/Other	Input
AB5	V _{SS}	Power/Other	
AB6	D63#	Source Sync	Input/Output
AB7	PWRGOOD	Async GTL+	Input
AB8	V _{CC}	Power/Other	
AB9	DBI3#	Source Sync	Input/Output

Table 5-2. Pin Listing by Pin Number (cont'd)

Pin No.	Pin Name	Signal Buffer Type	Direction
AB10	D55#	Source Sync	Input/Output
AB11	V _{SS}	Power/Other	
AB12	D51#	Source Sync	Input/Output
AB13	D52#	Source Sync	Input/Output
AB14	V _{CC}	Power/Other	
AB15	D37#	Source Sync	Input/Output
AB16	D32#	Source Sync	Input/Output
AB17	D31#	Source Sync	Input/Output
AB18	V _{CC}	Power/Other	
AB19	D14#	Source Sync	Input/Output
AB20	D12#	Source Sync	Input/Output
AB21	V _{SS}	Power/Other	
AB22	D13#	Source Sync	Input/Output
AB23	D9#	Source Sync	Input/Output
AB24	V _{CC}	Power/Other	
AB25	D8#	Source Sync	Input/Output
AB26	D7#	Source Sync	Input/Output
AB27	V _{SS}	Power/Other	
AB28	SM_EP_A2	SMBus	Input
AB29	SM_EP_A1	SMBus	Input
AB30	V _{CC}	Power/Other	
AB31	V _{SS}	Power/Other	
AC1	Reserved		
AC2	V _{SS}	Power/Other	
AC3	V _{CC}	Power/Other	
AC4	Don't Care		
AC5	D60#	Source Sync	Input/Output
AC6	D59#	Source Sync	Input/Output
AC7	V _{SS}	Power/Other	
AC8	D56#	Source Sync	Input/Output
AC9	D47#	Source Sync	Input/Output
AC10	V _{TT}	Power/Other	
AC11	D43#	Source Sync	Input/Output
AC12	D41#	Source Sync	Input/Output
AC13	V _{SS}	Power/Other	
AC14	D50#	Source Sync	Input/Output
AC15	DP2#	Common Clk	Input/Output
AC16	V _{CC}	Power/Other	
AC17	D34#	Source Sync	Input/Output

Table 5-2. Pin Listing by Pin Number (cont'd)

Pin No.	Pin Name	Signal Buffer Type	Direction
AC18	DP0#	Common Clk	Input/Output
AC19	V _{SS}	Power/Other	
AC20	D25#	Source Sync	Input/Output
AC21	D26#	Source Sync	Input/Output
AC22	V _{CC}	Power/Other	
AC23	D23#	Source Sync	Input/Output
AC24	D20#	Source Sync	Input/Output
AC25	V _{SS}	Power/Other	
AC26	D17#	Source Sync	Input/Output
AC27	DBI0#	Source Sync	Input/Output
AC28	SM_CLK	SMBus	Input
AC29	SM_DAT	SMBus	Output
AC30	SLEW_CTRL	Power/Other	Input
AC31	V _{CC}	Power/Other	
AD1	Reserved		
AD2	V _{CC}	Power/Other	
AD3	V _{SS}	Power/Other	
AD4	V _{CC} IOPLL	Power/Other	Input
AD5	TESTHI5	Power/Other	Input
AD6	Don't Care		
AD7	D57#	Source Sync	Input/Output
AD8	D46#	Source Sync	Input/Output
AD9	V _{SS}	Power/Other	
AD10	D45#	Source Sync	Input/Output
AD11	D40#	Source Sync	Input/Output
AD12	V _{TT}	Power/Other	
AD13	D38#	Source Sync	Input/Output
AD14	D39#	Source Sync	Input/Output
AD15	V _{SS}	Power/Other	
AD16	COMP0	Power/Other	Input
AD17	V _{SS}	Power/Other	
AD18	D36#	Source Sync	Input/Output
AD19	D30#	Source Sync	Input/Output
AD20	V _{CC}	Power/Other	
AD21	D29#	Source Sync	Input/Output
AD22	DBI1#	Source Sync	Input/Output
AD23	V _{SS}	Power/Other	
AD24	D21#	Source Sync	Input/Output

Table 5-2. Pin Listing by Pin Number (cont'd)

Pin No.	Pin Name	Signal Buffer Type	Direction
AD25	D18#	Source Sync	Input/Output
AD26	V _{CC}	Power/Other	
AD27	D4#	Source Sync	Input/Output
AD28	SM_ALERT#	SMBus	Output
AD29	SM_WP	SMBus	Input
AD30	Don't Care		
AD31	Don't Care		
AE2	Don't Care		
AE3	Don't Care		
AE4	V _{TT}	Power/Other	
AE5	TESTHI6	Power/Other	Input
AE6	V _{SS}	Power/Other	Input
AE7	D58#	Source Sync	Input/Output
AE8	Don't Care		
AE9	D44#	Source Sync	Input/Output
AE10	D42#	Source Sync	Input/Output
AE11	V _{SS}	Power/Other	
AE12	DBI2#	Source Sync	Input/Output
AE13	D35#	Source Sync	Input/Output
AE14	V _{CC}	Power/Other	
AE15	Don't Care		
AE16	Don't Care		
AE17	DP3#	Common Clk	Input/Output
AE18	V _{CC}	Power/Other	
AE19	DP1#	Common Clk	Input/Output
AE20	D28#	Source Sync	Input/Output
AE21	V _{SS}	Power/Other	
AE22	D27#	Source Sync	Input/Output
AE23	D22#	Source Sync	Input/Output
AE24	V _{CC}	Power/Other	
AE25	D19#	Source Sync	Input/Output
AE26	D16#	Source Sync	Input/Output
AE27	V _{SS}	Power/Other	
AE28	SM_VCC	Power/Other	
AE29	SM_VCC	Power/Other	
AE30	Reserved		

§





6 Signal Definitions

6.1 Signal Definitions

Table 6-1. Signal Definitions (Sheet 1 of 7)

Name	Type	Description												
A[39:3]#	I/O	<p>A[39:3]# (Address) define a 2⁴⁰-byte physical memory address space. In sub-phase 1 of the address phase, these pins transmit the address of a transaction. In sub-phase 2, these pins transmit transaction type information. These signals must connect the appropriate pins of all agents on the 64-bit Intel® Xeon™ processor MP with 1MB L2 cache FSB. A[39:3]# are protected by parity signals AP[1:0]#. A[39:3]# are source synchronous signals and are latched into the receiving buffers by ADSTB[1:0]#.</p> <p>On the active-to-inactive transition of RESET#, the processors sample a subset of the A[39:3]# pins to determine their power-on configuration. See Section 8.1.</p>												
A20M#	I	<p>If A20M# (Address-20 Mask) is asserted, the processor masks physical address bit 20 (A20#) before looking up a line in any internal cache and before driving a read/write transaction on the bus. Asserting A20M# emulates the 8086 processor's address wrap-around at the 1-Mbyte boundary. Assertion of A20M# is only supported in real mode.</p> <p>A20M# is an asynchronous signal. However, to ensure recognition of this signal following an I/O write instruction, it must be valid 6 clks before the I/O write's response.</p>												
ADS#	I/O	<p>ADS# (Address Strobe) is asserted to indicate the validity of the transaction address on the A[39:3]# and transaction request type on REQ[4:0]# pins. All bus agents observe the ADS# activation to begin parity checking, protocol checking, address decode, internal snoop, or deferred reply ID match operations associated with the new transaction. This signal must connect the appropriate pins on all 64-bit Intel® Xeon™ processor MP with 1MB L2 cache FSB agents.</p>												
ADSTB[1:0]#	I/O	<p>Address strobes are used to latch A[39:3]# and REQ[4:0]# on their rising and falling edge.</p>												
AP[1:0]#	I/O	<p>AP[1:0]# (Address Parity) are driven by the requestor one common clock after ADS#, A[39:3]#, REQ[4:0]# are driven. A correct parity signal is electrically high if an even number of covered signals are electrically low and electrically low if an odd number of covered signals are electrically low. This allows parity to be electrically high when all the covered signals are electrically high. AP[1:0]# should connect the appropriate pins of all 64-bit Intel® Xeon™ processor MP with 1MB L2 cache FSB agents. The following table defines the coverage for these signals.</p> <table border="1" style="margin-left: auto; margin-right: auto;"> <thead> <tr> <th>Request Signals</th> <th>Subphase 1</th> <th>Subphase 2</th> </tr> </thead> <tbody> <tr> <td>A[39:24]#</td> <td>AP0#</td> <td>AP1#</td> </tr> <tr> <td>A[23:3]#</td> <td>AP1#</td> <td>AP0#</td> </tr> <tr> <td>REQ[4:0]#</td> <td>AP1#</td> <td>AP0#</td> </tr> </tbody> </table>	Request Signals	Subphase 1	Subphase 2	A[39:24]#	AP0#	AP1#	A[23:3]#	AP1#	AP0#	REQ[4:0]#	AP1#	AP0#
Request Signals	Subphase 1	Subphase 2												
A[39:24]#	AP0#	AP1#												
A[23:3]#	AP1#	AP0#												
REQ[4:0]#	AP1#	AP0#												
BCLK[1:0]	I	<p>The differential bus clock pair BCLK[1:0] determines the bus frequency. All processor FSB agents must receive these signals to drive their outputs and latch their inputs.</p> <p>All external timing parameters are specified with respect to the rising edge of BCLK0 crossing the falling edge of BCLK1.</p>												

Table 6-1. Signal Definitions (Sheet 2 of 7)

Name	Type	Description									
BINIT#	I/O	<p>BINIT# (Bus Initialization) may be observed and driven by all processor FSB agents. If used, BINIT# must connect the appropriate pins of all such agents. If the BINIT# driver is enabled, BINIT# is asserted to signal any bus condition that prevents reliable future operation.</p> <p>If BINIT# observation is enabled during power-on configuration (see Section 8.1) and BINIT# is sampled asserted, symmetric agents reset their bus LOCK# activity and bus request arbitration state machines. The bus agents do not reset their I/O Queue (IOQ) and transaction tracking state machines upon observation of BINIT# assertion. Once the BINIT# assertion has been observed, the bus agents will re-arbitrate for the FSB and attempt completion of their bus queue and IOQ entries.</p> <p>If BINIT# observation is enabled during power on configuration, a central agent may handle an assertion of BINIT# as appropriate to the error handling architecture of the system.</p>									
BNR#	I/O	<p>BNR# (Block Next Request) is used to assert a bus stall by any bus agent who is unable to accept new bus transactions. During a bus stall, the current bus owner cannot issue any new transactions.</p> <p>Since multiple agents might need to request a bus stall at the same time, BNR# is a wire-OR signal which must connect the appropriate pins of all processor system bus agents. In order to avoid wire-OR glitches associated with simultaneous edge transitions driven by multiple drivers, BNR# is activated on specific clock edges and sampled on specific clock edges.</p>									
BOOT_SELECT	I	<p>The BOOT_SELECT input informs the processor whether the platform supports the 64-bit Intel® Xeon™ processor MP with 1MB L2 cache. Incompatible platform designs will have this input connected to V_{SS}. Thus, this pin is essentially an electrical key to prevent the 64-bit Intel® Xeon™ processor MP with 1MB L2 cache from running in a system that is not designed for it. For platforms that are designed to support the 64-bit Intel® Xeon™ processor MP with 1MB L2 cache, this pin should be changed to a no-connect.</p>									
BPM[5:0]#	I/O	<p>BPM[5:0]# (Breakpoint Monitor) are breakpoint and performance monitor signals. They are outputs from the processor which indicate the status of breakpoints and programmable counters used for monitoring processor performance. BPM[5:0]# should connect the appropriate pins of all 64-bit Intel® Xeon™ processor MP with 1MB L2 cache FSB agents.</p> <p>BPM4# provides PRDY# (Probe Ready) functionality for the TAP port. PRDY# is a processor output used by debug tools to determine processor debug readiness.</p> <p>BPM5# provides PREQ# (Probe Request) functionality for the TAP port. PREQ# is used by debug tools to request debug operation of the processors.</p> <p>BPM[5:4]# must be bussed to all bus agents. Please refer to the appropriate platform design guide for more detailed information.</p>									
BPRI#	I	<p>BPRI# (Bus Priority Request) is used to arbitrate for ownership of the processor FSB. It must connect the appropriate pins of all processor FSB agents. Observing BPRI# active (as asserted by the priority agent) causes all other agents to stop issuing new requests, unless such requests are part of an ongoing locked operation. The priority agent keeps BPRI# asserted until its requests are issued, then releases the bus by deasserting BPRI#.</p>									
BR0# BR[3:1]#	I/O I	<p>BR[3:0]# (Bus Request) drive the BREQ[3:0]# signals in the system. The BREQ[3:0]# signals are interconnected in a rotating manner to individual processor pins. The tables below give the rotating interconnect between the processor and bus signals for 3-load configurations.</p> <p>BR[1:0]# Signals Rotating Interconnect, 3-Load Configuration</p> <table border="1"> <thead> <tr> <th>Bus Signal</th> <th>Agent 0 Pins</th> <th>Agent 1 Pins</th> </tr> </thead> <tbody> <tr> <td>BREQ0#</td> <td>BR0#</td> <td>BR1#</td> </tr> <tr> <td>BREQ1#</td> <td>BR1#</td> <td>BR0#</td> </tr> </tbody> </table> <p>BR2# and BR3# must not be utilized in 3-load configurations. However, they must still be terminated.</p> <p>During power-on configuration, the central agent must assert the BREQ0# bus signal. All symmetric agents sample their BR[3:0]# pins on the active-to-inactive transition of RESET#. The pin which the agent samples asserted determines its agent ID.</p>	Bus Signal	Agent 0 Pins	Agent 1 Pins	BREQ0#	BR0#	BR1#	BREQ1#	BR1#	BR0#
Bus Signal	Agent 0 Pins	Agent 1 Pins									
BREQ0#	BR0#	BR1#									
BREQ1#	BR1#	BR0#									

Table 6-1. Signal Definitions (Sheet 3 of 7)

Name	Type	Description										
BSEL[1:0]	O	These output signals are used to select the FSB frequency. The frequency is determined by the processor(s), chipset, and frequency synthesizer capabilities. All FSB agents must operate at the same frequency. Individual processors will only operate at their specified FSB frequency. See the appropriate platform design guide for implementation examples. See Table 2-2 for output values. Refer to the appropriate platform design guide for termination recommendations.										
COMP0	I	COMP0 must be terminated to V_{SS} on the baseboard using precision resistors. This input configures the AGTL+ drivers of the processor. Refer to the appropriate platform design guide and Table 2-18 for implementation details.										
D[63:0]#	I/O	D[63:0]# (Data) are the data signals. These signals provide a 64-bit data path between the processor FSB agents, and must connect the appropriate pins on all such agents. The data driver asserts DRDY# to indicate a valid data transfer. D[63:0]# are quad-pumped signals, and will thus be driven four times in a common clock period. D[63:0]# are latched off the falling edge of both DSTBP[3:0]# and DSTBN[3:0]#. Each group of 16 data signals correspond to a pair of one DSTBP# and one DSTBN#. The following table shows the grouping of data signals to strobes and DBI#. Furthermore, the DBI# pins determine the polarity of the data signals. Each group of 16 data signals corresponds to one DBI# signal. When the DBI# signal is active, the corresponding data group is inverted and therefore sampled active high.										
DBI[3:0]#	I/O	DBI[3:0]# are source synchronous and indicate the polarity of the D[63:0]# signals. The DBI[3:0]# signals are activated when the data on the data bus is inverted. If more than half the data bits, within a 16-bit group, would have been asserted electronically low, the bus agent may invert the data bus signals for that particular sub-phase for that 16-bit group. DBI[3:0] Assignment To Data Bus										
		<table border="1"> <thead> <tr> <th>Bus Signal</th> <th>Data Bus Signals</th> </tr> </thead> <tbody> <tr> <td>DBI0#</td> <td>D[15:0]#</td> </tr> <tr> <td>DBI1#</td> <td>D[31:16]#</td> </tr> <tr> <td>DBI2#</td> <td>D[47:32]#</td> </tr> <tr> <td>DBI3#</td> <td>D[63:48]#</td> </tr> </tbody> </table>	Bus Signal	Data Bus Signals	DBI0#	D[15:0]#	DBI1#	D[31:16]#	DBI2#	D[47:32]#	DBI3#	D[63:48]#
Bus Signal	Data Bus Signals											
DBI0#	D[15:0]#											
DBI1#	D[31:16]#											
DBI2#	D[47:32]#											
DBI3#	D[63:48]#											
DBSY#	I/O	DBSY# (Data Bus Busy) is asserted by the agent responsible for driving data on the processor FSB to indicate that the data bus is in use. The data bus is released after DBSY# is deasserted. This signal must connect the appropriate pins on all processor FSB agents.										
DEFER#	I	DEFER# is asserted by an agent to indicate that a transaction cannot be guaranteed in-order completion. Assertion of DEFER# is normally the responsibility of the addressed memory or I/O agent. This signal must connect the appropriate pins of all processor FSB agents.										
DP[3:0]#	I/O	DP[3:0]# (Data Parity) provide optional parity protection for the data bus. They are driven by the agent responsible for driving D[63:0]#, and, if parity is implemented, must connect the appropriate pins of all bus agents which use them.										
DRDY#	I/O	DRDY# (Data Ready) is asserted by the data driver on each data transfer, indicating valid data on the data bus. In a multi-common clock data transfer, DRDY# may be deasserted to insert idle clocks. This signal must connect the appropriate pins of all processor FSB agents.										
DSTBN[3:0]#	I/O	Data strobe used to latch in D[63:0]# and DBI[3:0]#.										
DSTBP[3:0]#	I/O	Data strobe used to latch in D[63:0]# and DBI[3:0]#.										

Table 6-1. Signal Definitions (Sheet 4 of 7)

Name	Type	Description
FERR#/PBE#	O	FERR#/PBE# (floating-point error/pending break event) is a multiplexed signal and its meaning is qualified by STPCLK#. When STPCLK# is not asserted, FERR#/PBE# indicates a floating-point error and will be asserted when the processor detects an unmasked floating-point error. When STPCLK# is not asserted, FERR#/PBE# is similar to the ERROR# signal on the Intel 387 coprocessor, and is included for compatibility with systems using MS-DOS*-type floating-point error reporting. When STPCLK# is asserted, an assertion of FERR#/PBE# indicates that the processor has a pending break event waiting for service. The assertion of FERR#/PBE# indicates that the processor should be returned to the Normal state. For additional information on the pending break event functionality, including the identification of support of the feature and enable/disable information, refer to Volume 3 of the <i>IA-32 Intel® Architecture Software Developer's Manual</i> and the <i>AP-485 Intel® Processor Identification and the CPUID Instruction</i> application note.
FORCEPR#	I	This input can be used to force activation of the Thermal Control Circuit.
GTLREF[3:0]	I	GTLREF determines the signal reference level for AGTL+ input pins. GTLREF is used by the AGTL+ receivers to determine if a signal is an electrical 0 or an electrical 1. Please refer to Table 2-18 for further details.
HIT# HITM#	I/O I/O	HIT# (Snoop Hit) and HITM# (Hit Modified) convey transaction snoop operation results. Any FSB agent may assert both HIT# and HITM# together to indicate that it requires a snoop stall, which can be continued by reasserting HIT# and HITM# together, every other common clock. Since multiple agents may deliver snoop results at the same time, HIT# and HITM# are wire-OR signals which must connect the appropriate pins of all processor FSB agents. In order to avoid wire-OR glitches associated with simultaneous edge transitions driven by multiple drivers, HIT# and HITM# are activated on specific clock edges and sampled on specific clock edges.
IERR#	O	IERR# (Internal Error) is asserted by a processor as the result of an internal error. Assertion of IERR# is usually accompanied by a SHUTDOWN transaction on the processor FSB. This transaction may optionally be converted to an external error signal (e.g., NMI) by system core logic. The processor will keep IERR# asserted until the assertion of RESET#.
IGNNE#	I	IGNNE# (Ignore Numeric Error) is asserted to force the processor to ignore a numeric error and continue to execute noncontrol floating-point instructions. If IGNNE# is deasserted, the processor generates an exception on a noncontrol floating-point instruction if a previous floating-point instruction caused an error. IGNNE# has no effect when the NE bit in control register 0 (CR0) is set. IGNNE# is an asynchronous signal. However, to ensure recognition of this signal following an I/O write instruction, it must be valid a 6 clocks before the I/O write's response.
INIT#	I	INIT# (Initialization), when asserted, resets integer registers inside all processors without affecting their internal caches or floating-point registers. Each processor then begins execution at the power-on Reset vector configured during power-on configuration. The processor continues to handle snoop requests during INIT# assertion. INIT# is an asynchronous signal and must connect the appropriate pins of all processor FSB agents. If INIT# is sampled active on the active to inactive transition of RESET#, then the processor executes its Built-in Self-Test (BIST).
LINT0/INTR LINT1/NMI	I	LINT[1:0] (Local APIC Interrupt) must connect the appropriate pins of all FSB agents. When the APIC functionality is disabled, the LINT0 signal becomes INTR, a maskable interrupt request signal, and LINT1 becomes NMI, a nonmaskable interrupt. INTR and NMI are backward compatible with the signals of those names on the Pentium processor. Both signals are asynchronous. These signals must be software configured via BIOS programming of the APIC register space to be used either as NMI/INTR or LINT[1:0]. Because the APIC is enabled by default after Reset, operation of these pins as LINT[1:0] is the default configuration.
LOCK#	I/O	LOCK# indicates to the system that a set of transactions must occur atomically. This signal must connect the appropriate pins of all processor FSB agents. For a locked sequence of transactions, LOCK# is asserted from the beginning of the first transaction to the end of the last transaction. When the priority agent asserts BPRI# to arbitrate for ownership of the processor FSB, it will wait until it observes LOCK# deasserted. This enables symmetric agents to retain ownership of the processor FSB throughout the bus locked operation and ensure the atomicity of lock.

Table 6-1. Signal Definitions (Sheet 5 of 7)

Name	Type	Description
MCERR#	I/O	<p>MCERR# (Machine Check Error) is asserted to indicate an unrecoverable error or a bus protocol violation. It may be driven by all processor FSB agents.</p> <p>MCERR# assertion conditions are configurable at a system level. Assertion options are defined as follows:</p> <ul style="list-style-type: none"> • Enabled or disabled. • Asserted, if configured, for internal errors along with IERR#. • Asserted, if configured, by the request initiator of a bus transaction after it observes an error. • Asserted by any bus agent when it observes an error in a bus transaction. <p>For more details regarding machine check architecture, refer to the <i>IA-32 Intel® Architecture Software Developer's Manual, Volume 3: System Programming Guide</i>.</p> <p>Since multiple agents may drive this signal at the same time, MCERR# is a wired-OR signal which must connect the appropriate pins of all processor FSB agents. In order to avoid wire-OR glitches associated with simultaneous edge transitions driven by multiple drivers, MCERR# is activated on specific clock edges and sampled on specific clock edges.</p>
ODTEN	I	<p>ODTEN (On-die termination enable) should be connected to V_{TT} through a resistor to enable on-die termination for end bus agents. For middle bus agents, pull this signal down via a resistor to ground to disable on-die termination. Whenever ODTEN is high, on-die termination will be active, regardless of other states of the bus.</p>
PROCHOT#	O	<p>The assertion of PROCHOT# (processor hot) indicates that the processor die temperature has reached its thermal limit. See Section 7.2.4 for more details.</p>
PROCTYPE	O	<p>PROCTYPE is used to identify when the 64-bit Intel® Xeon™ processor MP with 1MB L2 cache is installed. This pin should be used to toggle logic needed for the 64-bit Intel® Xeon™ processor MP with 1MB L2 cache or 64-bit Intel® Xeon™ processor MP with up to 8M L3 cache. The pin is left floating on the 64-bit Intel® Xeon™ processor MP with 1MB L2 cache package while on the 64-bit Intel® Xeon™ processor MP with up to 8M L3 cache package this pin connects to V_{SS}.</p>
PWRGOOD	I	<p>PWRGOOD (Power Good) is an input. The processor requires this signal to be a clean indication that all 64-bit Intel® Xeon™ processor MP with 1MB L2 cache clocks and power supplies are stable and within their specifications. “Clean” implies that the signal will remain low (capable of sinking leakage current), without glitches, from the time that the power supplies are turned on until they come within specification. The signal must then transition monotonically to a high state. Figure 2-17 illustrates the relationship of PWRGOOD to the RESET# signal. PWRGOOD can be driven inactive at any time, but clocks and power must again be stable before a subsequent rising edge of PWRGOOD. It must also meet the minimum pulse width specification in Table 2-20, and be followed by a 1 ms active RESET# pulse.</p> <p>The PWRGOOD signal must be supplied to the processor. This signal is used to protect internal circuits against voltage sequencing issues. It should be driven high throughout boundary scan operation.</p>
REQ[4:0]#	I/O	<p>REQ[4:0]# (Request Command) must connect the appropriate pins of all processor FSB agents. They are asserted by the current bus owner to define the currently active transaction type. These signals are source synchronous to ADSTB[1:0]#. Refer to the AP[1:0]# signal description for details on parity checking of these signals.</p>
RESET#	I	<p>Asserting the RESET# signal resets all processors to known states and invalidates their internal caches without writing back any of their contents. For a power-on Reset, RESET# must stay active for at least 1 ms after V_{CC} and BCLK have reached their specified levels. On observing active RESET#, all FSB agents will deassert their outputs within two clocks. RESET# must not be kept asserted for more than 10 ms after PWRGOOD is asserted.</p> <p>A number of bus signals are sampled at the active-to-inactive transition of RESET# for power-on configuration. These configuration options are described in Section 8.1.</p>
RS[2:0]#	I	<p>RS[2:0]# (Response Status) are driven by the response agent (the agent responsible for completion of the current transaction), and must connect the appropriate pins of all processor FSB agents.</p>

Table 6-1. Signal Definitions (Sheet 6 of 7)

Name	Type	Description
RSP#	I	RSP# (Response Parity) is driven by the response agent (the agent responsible for completion of the current transaction) during assertion of RS[2:0]#, the signals for which RSP# provides parity protection. It must connect to the appropriate pins of all processor FSB agents. A correct parity signal is electrically high if an even number of covered signals are electrically low and electrically low if an odd number of covered signals are electrically low. If RS[2:0]# are all electrically high, RSP# is also electrically high, since this indicates it is not being driven by any agent guaranteeing correct parity.
SKTOCC#	O	SKTOCC# (Socket occupied) will be pulled to ground by the processor to indicate that the processor is present. There is no connection to the processor silicon for this signal.
SLEW_CTRL	I	SLEW_CTRL must be connected to ground through 49.9 ohm resistor on middle agent and floating when connected to end agent. This input configures the slew rate of the AGTL+ drivers. Refer to the appropriate platform design guide and Table 2-18 for implementation details.
SM_ALERT#	O	SM_ALERT# (SMBus Alert) is an asynchronous interrupt line associated with the SMBus Thermal Sensor device. It is an open-drain output and the processor includes a 10 k Ω pull-up resistor to SM_VCC for this signal. For more information on the usage of the SM_ALERT# pin, see Section 8.4.7 .
SM_CLK	I/O	The SM_CLK (SMBus Clock) signal is an input clock to the system management logic which is required for operation of the system management features of the 64-bit Intel [®] Xeon [™] processor MP with 1MB L2 cache. This clock is driven by the SMBus controller and is asynchronous to other clocks in the processor. The processor includes a 10 k Ω pull-up resistor to SM_VCC for this signal.
SM_DAT	I/O	The SM_DAT (SMBus Data) signal is the data signal for the SMBus. This signal provides the single-bit mechanism for transferring data between SMBus devices. The processor includes a 10k Ω pull-up resistor to SM_VCC for this signal.
SM_EP_A[2:0]	I	The SM_EP_A (EEPROM Select Address) pins are decoded on the SMBus in conjunction with the upper address bits in order to maintain unique addresses on the SMBus in a system with multiple processors. To set an SM_EP_A line high, a pull-up resistor should be used that is no larger than 1 k Ω . The processor includes a 10 k Ω pull-down resistor to V _{SS} for each of these signals. For more information on the usage of these pins, see Section 8.4.8 .
SM_TS_A[1:0]	I	The SM_TS_A (Thermal Sensor Select Address) pins are decoded on the SMBus in conjunction with the upper address bits in order to maintain unique addresses on the SMBus in a system with multiple processors. The device's addressing, as implemented, includes a Hi-Z state for both address pins. The use of the Hi-Z state is achieved by leaving the input floating (unconnected). For more information on the usage of these pins, see Section 8.4.8 .
SM_VCC	I	SM_VCC provides power to the SMBus components on the 64-bit Intel [®] Xeon [™] processor MP with 1MB L2 cache package.
SM_WP	I	WP (Write Protect) can be used to write protect the Scratch EEPROM. The Scratch EEPROM is write-protected when this input is pulled high to SM_VCC. The processor includes a 10 k Ω pull-down resistor to V _{SS} for this signal.
SMI#	I	SMI# (System Management Interrupt) is asserted asynchronously by system logic. On accepting a System Management Interrupt, processors save the current state and enter System Management Mode (SMM). An SMI Acknowledge transaction is issued, and the processor begins program execution from the SMM handler. If SMI# is asserted during the deassertion of RESET#, the processor will tri-state its outputs.
STPCLK#	I	STPCLK# (Stop Clock), when asserted, causes processors to enter a low power Stop-Grant state. The processor issues a Stop-Grant Acknowledge transaction, and stops providing internal clock signals to all processor core units except the FSB and APIC units. The processor continues to snoop bus transactions and service interrupts while in Stop-Grant state. When STPCLK# is deasserted, the processor restarts its internal clock to all units and resumes execution. The assertion of STPCLK# has no effect on the bus clock; STPCLK# is an asynchronous input.
TCK	I	TCK (Test Clock) provides the clock input for the processor Test Access Port.
TDI	I	TDI (Test Data In) transfers serial test data into the processor. TDI provides the serial input needed for JTAG specification support.

Table 6-1. Signal Definitions (Sheet 7 of 7)

Name	Type	Description
TDO	O	TDO (Test Data Out) transfers serial test data out of the processor. TDO provides the serial output needed for JTAG specification support.
TEST_BUS	I	Must be connected to all other processor TEST_BUS signals in the system. See the appropriate platform design guideline for termination details.
TESTHI[6:0]	I	TESTHI[6:0] must be connected to a V_{TT} power source through a resistor for proper processor operation. See Section 2.3 for more details.
THERMTRIP#	O	Assertion of THERMTRIP# (Thermal Trip) indicates the processor junction temperature has reached a temperature beyond which permanent silicon damage may occur. THERMTRIP# (Thermal Trip) will activate at a temperature that is approximately 20°C above the maximum case temperature (T_C). Measurement of the temperature is accomplished through an internal thermal sensor. Upon assertion of THERMTRIP#, the processor will shut off its internal clocks (thus halting program execution) in an attempt to reduce the processor junction temperature. To protect the processor its core voltage (V_{CC}) must be removed following the assertion of THERMTRIP#. See Figure 2-14 and Table 2-22 for the appropriate power down sequence and timing requirements. Driving of the THERMTRIP# signals is enabled within 10 μ s of the assertion of PWRGOOD and is disabled on de-assertion of PWRGOOD. Once activated, THERMTRIP# remains latched until PWRGOOD is de-asserted. While the de-assertion of the PWRGOOD signal will de-assert THERMTRIP#, if the processor's junction temperature remains at or above the trip level, THERMTRIP# will again be asserted within 10 μ s of the assertion of PWRGOOD. Thermtrip should not be sampled until 10 μ s after PWRGOOD assertion at the processor.
TMS	I	TMS (Test Mode Select) is a JTAG specification support signal used by debug tools.
TRDY#	I	TRDY# (Target Ready) is asserted by the target (chipset) to indicate that it is ready to receive a write or implicit writeback data transfer. TRDY# must connect the appropriate pins of all FSB agents.
TRST#	I	TRST# (Test Reset) resets the Test Access Port (TAP) logic. TRST# must be driven electrically low during power on Reset. Please refer to the <i>eXtended Debug Port: Debug Port Design Guide for Intel® E8500 Chipset Platforms</i> or the <i>eXtended Debug Port: Debug Port Design Guide for MP Platforms</i> for details.
V_{CC}	I	V_{CC} provides power to the core logic of the 64-bit Intel® Xeon™ processor MP with 1MB L2 cache.
V_{CCA}	I	V_{CCA} provides isolated power for the analog portion of the internal PLL's. Use a discrete RLC filter to provide clean power. Refer to the appropriate platform design guide for complete implementation details.
$V_{CCIOPLL}$	I	$V_{CCIOPLL}$ provides isolated power for digital portion of the internal PLL's. Follow the guidelines for V_{CCA} , and refer to the appropriate platform design guide for complete implementation details.
$V_{CCSENSE}$ $V_{SSSENSE}$	O	$V_{CCSENSE}$ and $V_{SSSENSE}$ provide isolated, low impedance connections to the processor core voltage (V_{CC}) and ground (V_{SS}). They can be used to sense or measure voltage or ground near the silicon with little noise.
VID[5:0]	O	VID[5:0] (Voltage ID) pins are used to support automatic selection of power supply voltages (V_{CC}). These are open drain signals that are driven by the processor and must be pulled through a resistor. Conversely, the VR output must be disabled prior to the voltage supply for these pins becoming invalid. The VID pins are needed to support processor voltage specification variations. See Table 2-3 for definitions of these pins. The V_{CC} VR must supply the voltage that is requested by these pins, or disable itself.
VIDPWRGD	I	The processor requires this input to determine that the supply voltage for BSEL[1:0] and VID[5:0] is stable and within specification.
V_{SS}	I	V_{SS} is the ground plane for the 64-bit Intel® Xeon™ processor MP with 1MB L2 cache.
V_{SSA}	I	V_{SSA} provides an isolated, internal ground for internal PLL's. Do not connect directly to ground. This pin is to be connected to V_{CCA} and $V_{CCIOPLL}$ through a discrete filter circuit.
V_{TT}	I	V_{TT} is the FSB termination voltage.
VTTEN	O	VTTEN can be used as an output enable for the V_{TT} regulator. VTTEN is used as an electrical key to prevent processors with mechanically-equivalent pinouts from accidentally booting in a 64-bit Intel® Xeon™ processor MP with 1MB L2 cache platform. Since VTTEN is an open circuit on the processor package, VTTEN must be pulled up on the motherboard. Refer to the appropriate platform design guide for implementation details.

§

7 Thermal Specifications

7.1 Package Thermal Specifications

The 64-bit Intel® Xeon™ processor MP with 1MB L2 cache requires a thermal solution to maintain temperatures within operating limits. Any attempt to operate the processor outside these operating limits may result in permanent damage to the processor and potentially other components within the system. As processor technology changes, thermal management becomes increasingly crucial when building computer systems. Maintaining the proper thermal environment is key to reliable, long-term system operation.

A complete solution includes both component and system level thermal management features. Component level thermal solutions can include active or passive heatsinks attached to the processor IHS. Typical system level thermal solutions may consist of system fans combined with ducting and venting.

For more information on designing a component level thermal solution, refer to the *64-bit Intel® Xeon™ Processor MP with 1MB L2 Cache Thermal/Mechanical Design Guidelines*.

Note: The boxed processor will ship with a component thermal solution. Refer to [Section 9](#) for details on the boxed processor.

7.1.1 Thermal Specifications

To allow the optimal operation and long-term reliability of Intel processor-based systems, the processor must remain within the minimum and maximum case temperature (T_{CASE}) specifications as defined by the applicable thermal profile (see [Table 7-1](#) and [Figure 7-1](#)). Thermal solutions not designed to provide this level of thermal capability may affect the long-term reliability of the processor and system. For more details on thermal solution design, please refer to the appropriate processor thermal/mechanical design guideline.

The 64-bit Intel® Xeon™ processor MP with 1MB L2 cache introduces a new methodology for managing processor temperatures which is intended to support acoustic noise reduction through fan speed control and assure processor reliability. Selection of the appropriate fan speed will be based on the temperature reported by the processor's Thermal Diode. If the diode temperature is greater than or equal to $T_{control}$ (see [Section 7.2.7](#)), then the processor case temperature must remain at or below the temperature as specified by the thermal profile (see [Figure 7-1](#)). If the diode temperature is less than $T_{control}$, then the case temperature is permitted to exceed the thermal profile, but the diode temperature must remain at or below $T_{control}$. Systems that implement fan speed control must be designed to take these conditions into account. Systems that do not alter the fan speed only need to guarantee the case temperature meets the thermal profile specifications.

The 64-bit Intel® Xeon™ processor MP with 1MB L2 cache thermal profile ensures adherence to Intel reliability requirements. The thermal profile is representative of a volumetrically unconstrained thermal solution (i.e. industry enabled 2U heatsink). In this scenario, it is expected that the Thermal Control Circuit (TCC) would only be activated for very brief periods of time when running the most power intensive applications. Refer to the *64-bit Intel® Xeon™ Processor MP with 1MB L2 Cache Thermal/Mechanical Design Guidelines* for details on system thermal solution design, thermal profiles, and environmental considerations.

The upper point of the thermal profile consists of the Thermal Design Power (TDP) defined in Table 7-1 and the associated T_{CASE_MAX} value. The lower point of the thermal profile consists of $x = P_{CONTROL_BASE}$ and $y = T_{CASE_MAX} @ P_{CONTROL_BASE}$. $P_{control}$ is defined as the processor power at which T_{CASE} , calculated from the thermal profile, corresponds to the lowest possible value of $T_{control}$. This point is associated with the $T_{control}$ value (see Section 7.2.7) However, because $T_{control}$ represents a diode temperature, it is necessary to define the associated case temperature. This is $T_{CASE_MAX} @ P_{CONTROL_BASE}$. Please see Section 7.2.7 and the 64-bit Intel® Xeon™ Processor MP with 1MB L2 Cache Thermal/Mechanical Design Guidelines for proper usage of the $T_{control}$ specification.

The case temperature is defined at the geometric top center of the processor IHS. Analysis indicates that real applications are unlikely to cause the processor to consume maximum power dissipation for sustained time periods. Intel recommends that complete thermal solution designs target the TDP indicated in Table 7-1, instead of the maximum processor power consumption. The Thermal Monitor feature is intended to help protect the processor in the event that an application exceeds the TDP recommendation for a sustained time period. For more details on this feature, refer to Section 7.2. To ensure maximum flexibility for future requirements, systems should be designed to the FMB guidelines, even if a processor with a lower thermal dissipation is currently planned. **Thermal Monitor or TM2 feature must be enabled for the processor to remain within specification.**

Table 7-1. 64-bit Intel® Xeon™ Processor MP with 1MB L2 Cache Thermal Specifications

Core Frequency (GHz)	Maximum Power (W)	Thermal Design Power (W)	Minimum T_{CASE} (°C)	Maximum T_{CASE} (°C)	Notes
3.16 GHz - FMB	120	110	5	See Figure 7-1; Table 7-2	1, 2, 3, 4, 5

NOTES:

1. These values are specified at V_{CC_MAX} for all processor frequencies. Systems must be designed to ensure the processor is not to be subjected to any static V_{CC} and I_{CC} combination wherein V_{CC} exceeds V_{CC_MAX} at specified I_{CC} . Please refer to the V_{CC} static and transient tolerance specifications in Section 2.
2. Listed frequencies are not necessarily committed production frequencies.
3. Maximum Power is the maximum thermal power that can be dissipated by the processor through the integrated heat spreader (IHS). Maximum Power is measured at maximum T_{CASE} .
4. Thermal Design Power (TDP) should be used for processor/chipset thermal solution design targets. TDP is not the maximum power that the processor can dissipate. TDP is measured at maximum T_{CASE} .
5. These specifications are based on silicon characterization, however they may be updated as further data becomes available.

Figure 7-1. 64-bit Intel® Xeon™ Processor MP with 1MB L2 Cache Thermal Profile A

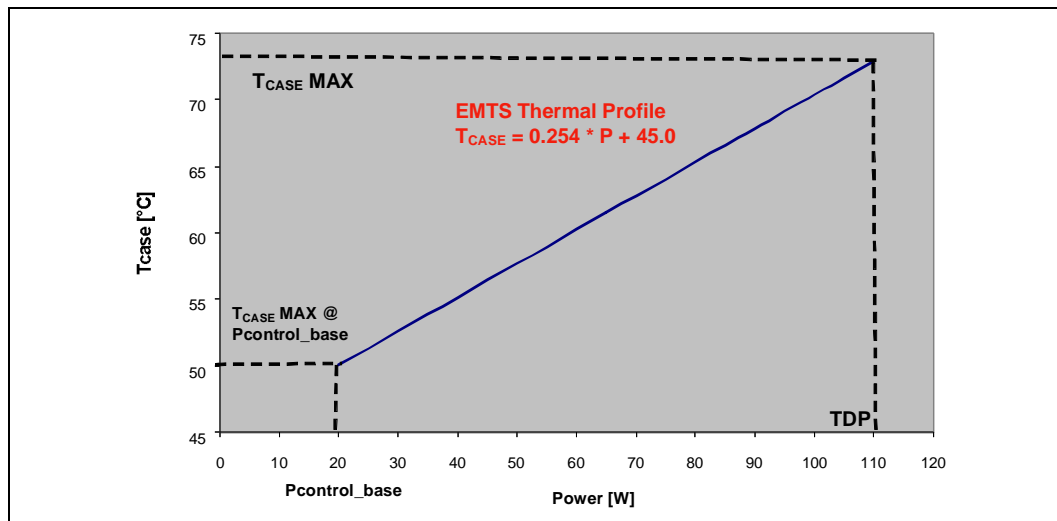

NOTE: Refer to the *64-bit Intel® Xeon™ Processor MP with 1MB L2 Cache Thermal/Mechanical Design Guidelines* for system and environmental implementation details.

Table 7-2. 64-bit Intel® Xeon™ Processor MP with 1MB L2 Cache Thermal Profile A

Thermal Profile A	
$\Psi_{ca} = 0.254$	C /W; T _A = 45 °C
Power	Temperature (°C)
20	50
25	51
30	53
35	54
40	55
45	56
50	58
55	59
60	60
65	62
70	63
75	64
80	65
85	67
90	68
100	70
105	72
110	73

7.1.2 Thermal Metrology

The maximum and minimum case temperatures (T_{CASE}) specified in [Table 7-1](#) are measured at the geometric top center of the processor IHS. [Figure 7-2](#) illustrates the location where T_{CASE} temperature measurements should be made. For detailed guidelines on temperature measurement methodology, refer to the *64-bit Intel® Xeon™ Processor MP with 1MB L2 Cache Thermal/Mechanical Design Guidelines*.

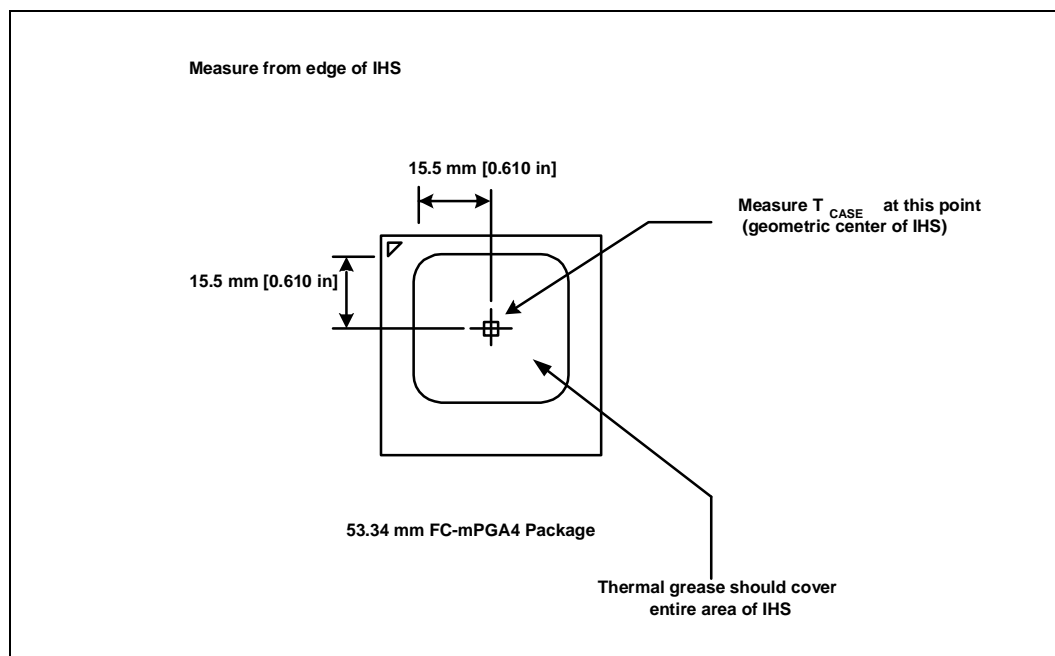
Figure 7-2. Case Temperature (T_{CASE}) Measurement Location

7.2 Processor Thermal Features

7.2.1 Thermal Monitor

The Thermal Monitor feature helps control the processor temperature by activating the TCC when the processor silicon reaches its maximum operating temperature. The TCC reduces processor power consumption as needed by modulating (starting and stopping) the internal processor core clocks. The Thermal Monitor (or TM2) must be enabled for the processor to be operating within specifications. The temperature at which Thermal Monitor activates the thermal control circuit is not user configurable and is not software visible. Bus traffic is snooped in the normal manner, and interrupt requests are latched (and serviced during the time that the clocks are on) while the TCC is active.

When the Thermal Monitor is enabled and a high temperature situation exists (i.e. TCC is active), the clocks will be modulated by alternately turning the clocks off and on at a duty cycle specific to the processor (typically 30-50%). Clocks will not be off for more than 3 microseconds when the TCC is active. Cycle times are processor speed dependent and will decrease as processor core frequencies increase. A small amount of hysteresis has been included to prevent rapid active/inactive transitions of the TCC when the processor temperature is near its maximum operating temperature. Once the temperature has dropped below the maximum operating temperature and the hysteresis timer has expired, the TCC goes inactive and clock modulation ceases.

With a thermal solution designed to meet the thermal profile, it is anticipated that the TCC would only be activated for very short periods of time when running the most power intensive applications. The processor performance impact due to these brief periods of TCC activation is expected to be so minor that it would be immeasurable. A thermal solution that is significantly

under-designed may not be capable of cooling the processor even when the TCC is active continuously. Refer to the *64-bit Intel® Xeon™ Processor MP with 1MB L2 Cache Thermal/Mechanical Design Guidelines* for information on designing a thermal solution.

The duty cycle for the TCC, when activated by the Thermal Monitor, is factory configured and cannot be modified. The Thermal Monitor does not require any additional hardware, software drivers, or interrupt handling routines.

7.2.2 Thermal Monitor 2

The 64-bit Intel® Xeon™ processor MP with 1MB L2 cache also supports a power management capability known as TM2. This mechanism provides an efficient means for limiting the processor temperature by reducing the power consumption within the processor. The Thermal Monitor (or Thermal Monitor 2) feature must be enabled for the processor to be operating within specifications.

When TM2 is enabled and a high temperature situation is detected, the TCC will be activated. The TCC causes the processor to adjust its operating frequency (via the bus multiplier) and input voltage (via the VID signals). This combination of reduced frequency and VID results in a decrease to the processor power consumption.

A processor enabled for TM2 includes two operating points, each consisting of a specific operating frequency and voltage. The first operating point represents the normal operating condition for the processor. Under this condition, the core-frequency-to-system-bus multiplier utilized by the processor is that contained in the IA32_FLEX_BRVID_SEL MSR and the VID is that specified in [Table 2-8](#). These parameters represent normal system operation.

The second point consists of both a lower operating frequency and voltage. When the TCC is activated, the processor automatically transitions to the new frequency. This transition occurs very rapidly (on the order of 5 microseconds). During the frequency transition, the processor is unable to service any bus requests, and consequently, all bus traffic is blocked. Edge-triggered interrupts will be latched and kept pending until the processor resumes operation at the new frequency.

Once the new operating frequency is engaged, the processor will transition to the new core operating voltage by issuing a new VID code to the voltage regulator. The voltage regulator must support dynamic VID steps in order to support TM2. During the voltage change, it will be necessary to transition through multiple VID codes to reach the target operating voltage. Each step will be one VID table entry (see [Table 2-9](#)). The processor continues to execute instructions during the voltage transition. Operation at the lower voltage reduces the power consumption of the processor.

A small amount of hysteresis has been included to prevent rapid active/inactive transitions of the TCC when the processor temperature is near its maximum operating temperature. Once the temperature has dropped below the maximum operating temperature, and the hysteresis timer has expired, the operating frequency and voltage transition back to the normal system operating point. Transition of the VID code will occur first, in order to ensure proper operation once the processor reaches its normal operating frequency. Refer to [Figure 7-3](#) for an illustration of this ordering.

If a processor has its Thermal Control Circuit activated via a TM2 event, and an Enhanced Intel SpeedStep technology transition to a higher target frequency (through the applicable MSR write) is attempted, this frequency transition will be delayed until the TCC is deactivated and the TM2 event is complete.

Figure 7-3. Thermal Monitor 2 Frequency and Voltage Ordering

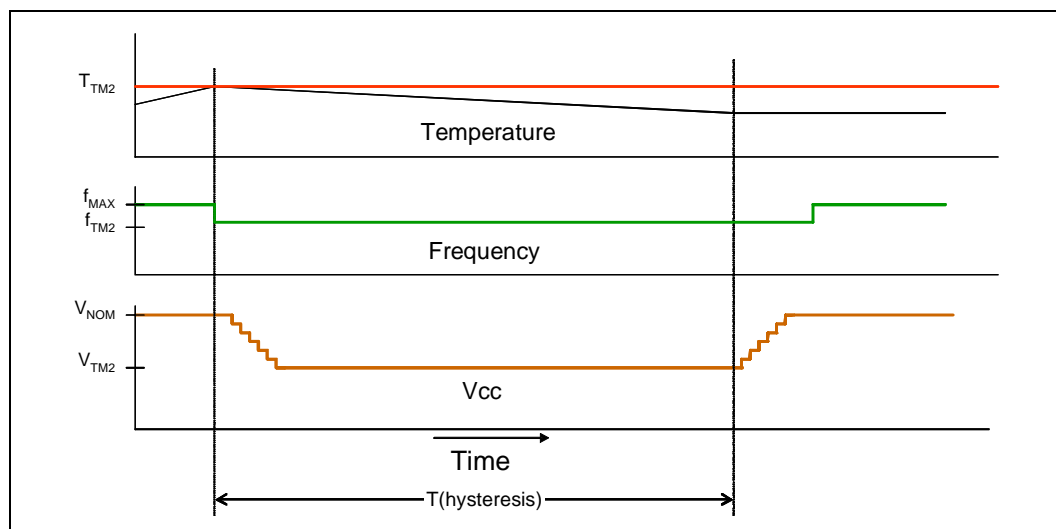

The PROCHOT# signal is asserted when a high temperature situation is detected, regardless of whether Thermal Monitor or TM2 is enabled.

Not all processors are capable of supporting TM2. More details on which processors will support this feature will be provided in future releases of the *64-bit Intel® Xeon™ Processor MP with 1MB L2 Cache Specification Update*.

7.2.3 On-Demand Mode

The processor provides an auxiliary mechanism that allows system software to force the processor to reduce its power consumption. This mechanism is referred to as “On-Demand” mode and is distinct from the Thermal Monitor and TM2 features. On-Demand mode is intended as a means to reduce system level power consumption. Systems utilizing the 64-bit Intel® Xeon™ processor MP with 1MB L2 cache must not rely on software usage of this mechanism to limit the processor temperature.

If bit 4 of the IA32_CLOCK_MODULATION MSR is written to a ‘1’, the processor will immediately reduce its power consumption via modulation (starting and stopping) of the internal core clock, independent of the processor temperature. When using On-Demand mode, the duty cycle of the clock modulation is programmable via bits 3:1 of the IA32_CLOCK_MODULATION MSR. In On-Demand mode, the duty cycle can be programmed from 12.5% on/ 87.5% off to 87.5% on/12.5% off in 12.5% increments. On-Demand mode may be used in conjunction with the Thermal Monitor. If the system tries to enable On-Demand mode at the same time the TCC is engaged, the factory configured duty cycle of the TCC will override the duty cycle selected by the On-Demand mode.

7.2.4 PROCHOT# Signal Pin

An external signal, PROCHOT# (processor hot), is asserted when the processor die temperature has reached its factory configured trip point. If the Thermal Monitor is enabled (note that the Thermal Monitor must be enabled for the processor to be operating within specification), the TCC will be active when PROCHOT# is asserted. The processor can be configured to generate an interrupt upon the assertion or deassertion of PROCHOT#. Refer to the *IA-32 Intel® Architecture Software Developer's Manual* for specific register and programming details.

PROCHOT# is designed to assert at or a few degrees higher than maximum T_{CASE} (as specified by the thermal profile) when dissipating TDP power, and cannot be interpreted as an indication of processor case temperature. This temperature delta accounts for processor package, lifetime, and manufacturing variations and attempts to ensure the Thermal Control Circuit is not activated below maximum T_{CASE} when dissipating TDP power. There is no defined or fixed correlation between the PROCHOT# trip temperature, the case temperature, or the thermal diode temperature. Thermal solutions must be designed to the processor specifications and cannot be adjusted based on experimental measurements of T_{CASE} , PROCHOT#, or T_{diode} on random processor samples.

7.2.5 FORCEPR# Signal Pin

The FORCEPR# (force power reduction) input can be used by the platform to force the 64-bit Intel® Xeon™ processor MP with 1MB L2 cache to activate the TCC. If the Thermal Monitor is enabled, the TCC will be activated upon the assertion of the FORCEPR# signal. The TCC will remain active until the system deasserts FORCEPR#. FORCEPR# is an asynchronous input. FORCEPR# can be used to thermally protect other system components. To use the voltage regulator (VR) as an example, when the FORCEPR# pin is asserted, the TCC in the processor will activate, reducing the current consumption of the processor and the corresponding temperature of the VR.

It should be noted that assertion of FORCEPR# does not automatically assert PROCHOT#. As mentioned previously, the PROCHOT# signal is asserted when a high temperature situation is detected. A minimum pulse width of 500 microseconds is recommended when FORCEPR# is asserted by the system. Sustained activation of the FORCEPR# pin may cause noticeable platform performance degradation.

Refer to the appropriate platform design guide for details on implementing the FORCEPR# signal feature.

7.2.6 THERMTRIP# Signal Pin

Regardless of whether or not Thermal Monitor or TM2 is enabled, in the event of a catastrophic cooling failure, the processor will automatically shut down when the silicon has reached an elevated temperature (refer to the THERMTRIP# definition in [Table 6-1](#)). At this point, the system bus signal THERMTRIP# will go active and stay active as described in [Table 6-1](#). THERMTRIP# activation is independent of processor activity and does not generate any bus cycles. If THERMTRIP# is asserted, processor core voltage (V_{CC}) must be removed within the timeframe defined in [Table 2-22](#) and [Figure 2-14](#). Intel also recommends removal of V_{TT} .

7.2.7 Tcontrol and Fan Speed Reduction

Tcontrol is a temperature specification based on a temperature reading from the thermal diode. The value for Tcontrol will be calibrated in manufacturing and configured for each processor. The Tcontrol temperature for a given processor can be obtained by reading the IA32_TEMPERATURE_TARGET MSR in the processor. The Tcontrol value that is read from the IA32_TEMPERATURE_TARGET MSR must be converted from Hexadecimal to Decimal and added to a base value of 50°C.

The value of Tcontrol may vary from 0x00h to 0x1Eh.

When Tdiode is above Tcontrol, then T_{CASE} must be at or below T_{CASE_MAX} as defined by the thermal profile (see [Figure 7-1](#) and [Table 7-2](#)). Otherwise, the processor temperature can be maintained at Tcontrol.

7.2.8 Thermal Diode

The processor incorporates an on-die thermal diode. A thermal sensor located on the processor package monitors the die temperature of the processor for thermal management/long term die temperature change purposes. The thermal diode is separate from the Thermal Monitor's thermal sensor and cannot be used to predict the behavior of the Thermal Monitor.

§

8 Features

8.1 Power-On Configuration Options

Several configuration options can be set by hardware. The 64-bit Intel® Xeon™ processor MP with 1MB L2 cache samples its hardware configuration at reset, on the active-to-inactive transition of RESET#. For specifications on these options, refer to [Table 8-1](#).

The sampled information configures the processor for subsequent operation. These configuration options can only be changed by another reset. All resets configure the processor. For most reset purposes, the processor does not distinguish between a “warm” reset and a “power-on” reset.

Table 8-1. Power-On Configuration Option Pins

Configuration Option	Pin	Notes
Output tri state	SMI#	1, 2
Execute BIST (Built-In Self Test)	INIT#	1, 2
In Order Queue de-pipelining (set IOQ depth to 1)	A7#	1, 2
Disable MCERR# observation	A9#	1, 2
Disable BINIT# observation	A10#	1, 2
Disable bus parking	A15#	1, 2
APIC Cluster ID	A[12:11]#	1, 2
Symmetric agent arbitration ID	BR[3:0]#	1, 2, 3
Disable Hyper-Threading Technology	A31#	1, 2

NOTES:

1. Asserting this signal during RESET# will select the corresponding option.
2. Address pins not identified in this table as configuration options should not be asserted during RESET#.
3. The 64-bit Intel® Xeon™ processor MP with 1MB L2 cache only utilizes the BR0# and BR1# signals. Please refer to the appropriate platform design guidelines for termination guidelines.

8.2 Clock Control and Low Power States

The processor allows the use of HALT and Stop-Grant states to reduce power consumption by stopping the clock to internal sections of the processor, depending on each particular state. See [Figure 8-1](#) for a visual representation of the processor low power states.

8.2.1 Normal State—State 1

This is the normal operating state for the processor.

8.2.2 HALT Power Down State—State 2

HALT is a low power state entered when the processor executes the HALT instruction. The processor transitions to the Normal state upon the occurrence of SMI#, BINIT#, INIT#, LINT[1:0] (NMI, INTR), or an interrupt delivered over the FSB. RESET# causes the processor to immediately initialize itself.

The return from a System Management Interrupt (SMI) handler can be to either Normal Mode or the HALT Power Down state. See the *IA-32 Intel® Architecture Software Developer's Manual, Volume III: System Programmer's Guide* for more information.

The system can generate a STPCLK# while the processor is in the HALT Power Down state. When the system deasserts the STPCLK# interrupt, the processor returns execution to the HALT state.

While in HALT Power Down state, the processor processes bus snoops and interrupts.

Figure 8-1. Stop Clock State Machine

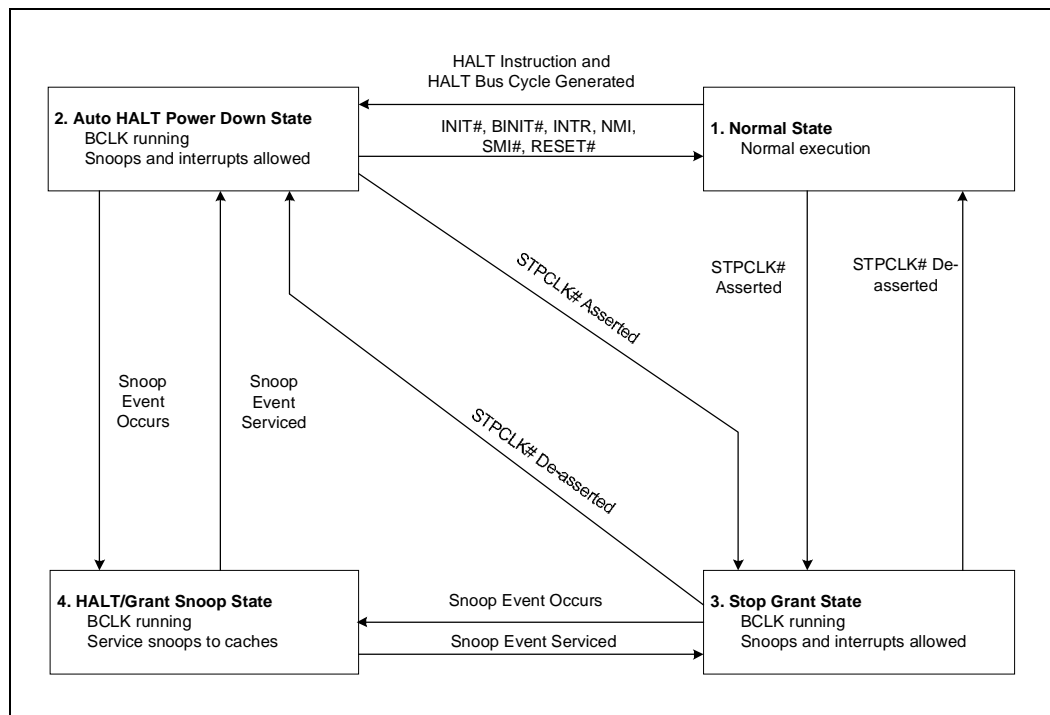

8.2.3 Stop-Grant State—State 3

When the STPCLK# pin is asserted, the Stop-Grant state of the processor is entered 20 bus clocks after the response phase of the processor-issued Stop Grant Acknowledge special bus cycle. For the 64-bit Intel® Xeon™ processor MP with 1MB L2 cache, both logical processors must be in the Stop-Grant state before the deassertion of STPCLK#.

Since the AGTL+ signal pins receive power from the FSB, these pins should not be driven (allowing the level to return to V_{TT}) for minimum power drawn by the termination resistors in this state. In addition, all other input pins on the FSB should be driven to the inactive state.

BINIT# is not serviced while the processor is in Stop-Grant state. The event is latched and can be serviced by software upon exit from the Stop-Grant state.

RESET# causes the processor to immediately initialize itself, but the processor will stay in Stop-Grant state. A transition back to the Normal state occurs with the deassertion of the STPCLK# signal.

A transition to the HALT/Grant Snoop state occurs when the processor detects a snoop on the FSB (see [Section 8.2.4](#)).

While in the Stop-Grant state, SMI#, INIT#, BINIT# and LINT[1:0] are latched by the processor, and only serviced when the processor returns to the Normal state. Only one occurrence of each event is recognized upon return to the Normal state.

While in Stop-Grant state, the processor processes snoops on the FSB and latches interrupts delivered on the FSB.

The PBE# signal can be driven when the processor is in Stop-Grant state. PBE# is asserted if there is any pending interrupt latched within the processor. Pending interrupts that are blocked by the EFLAGS.IF bit being clear still cause assertion of PBE#. Assertion of PBE# indicates to system logic that it should return the processor to the Normal state.

8.2.4 HALT/Grant Snoop State—State 4

The processor responds to snoop or interrupt transactions on the FSB while in Stop-Grant state or in HALT Power Down state. During a snoop or interrupt transaction, the processor enters the HALT/Grant Snoop state. The processor stays in this state until the snoop on the FSB has been serviced (whether by the processor or another agent on the FSB) or the interrupt has been latched. After the snoop is serviced or the interrupt is latched, the processor will return to the Stop-Grant state or HALT Power Down state, as appropriate.

8.3 Enhanced Intel SpeedStep Technology

Enhanced Intel SpeedStep technology enables the processor to switch between multiple frequency and voltage points, which may result in platform power savings. In order to support this technology, the system must support dynamic VID transitions. Switching between voltage/frequency states is software controlled.

Note: Not all processors are capable of supporting Enhanced Intel SpeedStep technology. More details on which processor frequencies will support this feature will be provided in future releases of the *64-bit Intel® Xeon™ Processor MP with 1MB L2 Cache Specification Update*.

Enhanced Intel SpeedStep technology is a technology that creates processor performance states (P-states). P-states are power consumption and capability states within the Normal state. Enhanced Intel SpeedStep technology enables real-time dynamic switching between frequency and voltage points. It alters the performance of the processor by changing the bus to core frequency ratio and voltage. This allows the processor to run at different core frequencies and voltages to best serve the performance and power requirements of the processor and system. Note that the FSB is not altered; only the internal core frequency is changed. In order to run at reduced power consumption, the voltage is altered in step with the bus ratio.

The following are key features of Enhanced Intel SpeedStep technology:

- Multiple voltage/frequency operating points provide optimal performance at reduced power consumption.
- Voltage/Frequency selection is software controlled by writing to processor MSR's (Model Specific Registers), thus eliminating chipset dependency.
 - If the target frequency is higher than the current frequency, Vcc is incremented in steps (+12.5 mV) by placing a new value on the VID signals and the processor shifts to the new frequency. Note that the top frequency for the processor can not be exceeded.

- If the target frequency is lower than the current frequency, the processor shifts to the new frequency and Vcc is then decremented in steps (–12.5 mV) by changing the target VID through the VID signals.

8.4 System Management Bus (SMBus) Interface

The 64-bit Intel® Xeon™ processor MP with 1MB L2 cache package includes an SMBus interface which allows access to a memory component with two sections (referred to as the Processor Information ROM and the Scratch EEPROM) and a thermal sensor on the substrate. The SMBus thermal sensor may be used to read the thermal diode mentioned in [Section 7.2.8](#). These devices and their features are described below.

The SMBus thermal sensor and its associated thermal diode are not related to and are completely independent of the precision, on-die temperature sensor and TCC of the Thermal Monitor or TM2 features discussed in [Section 7.2.1](#).

The processor SMBus implementation uses the clock and data signals of the *System Management Bus (SMBus) Specification*. It does not implement the SMBSUS# signal. Layout and routing guidelines are available in the appropriate platform design guide document.

For platforms which do not implement any of the SMBus features found on the processor, all of the SMBus connections, **except SM_VCC**, to the socket pins may be left unconnected (SM_ALERT#, SM_CLK, SM_DAT, SM_EP_A[2:0], SM_TS_A[1:0], SM_WP).

Figure 8-2. Logical Schematic of SMBus Circuitry

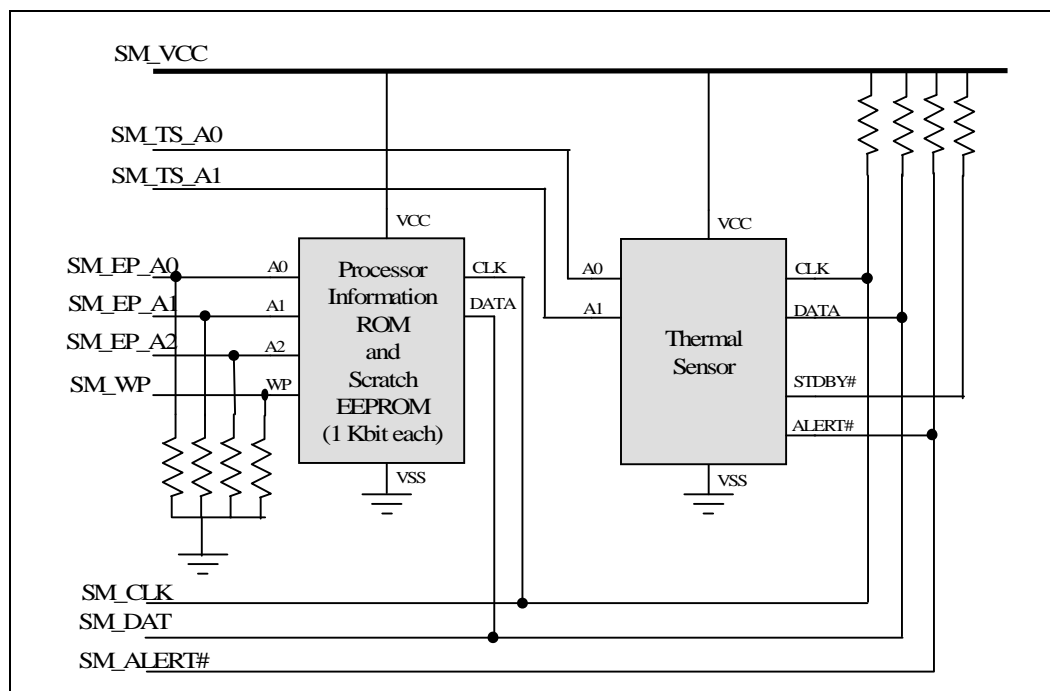

NOTE: Actual implementation may vary. This figure is provided to offer a general understanding of the architecture. All SMBus pull-up and pull-down resistors are 10 kΩ and located on the processor.

8.4.1 Processor Information ROM (PIROM)

The lower half (128 bytes) of the SMBus memory component is an electrically programmed read-only memory with information about the processor. This information is permanently write-protected. Table 8-2 shows the data fields and formats provided in the Processor Information ROM (PIROM).

Table 8-2. Processor Information ROM Format (Sheet 1 of 2)

Offset/Section	# of Bits	Function	Notes
Header:			
00h	8	Data Format Revision	Two 4-bit hex digits
01 - 02h	16	EEPROM Size	Size in bytes (MSB first)
03h	8	Processor Data Address	Byte pointer, 00h if not present
04h	8	Processor Core Data Address	Byte pointer, 00h if not present
05h	8	Reserved	Reserved
06h	8	Package Data Address	Byte pointer, 00h if not present
07h	8	Part Number Data Address	Byte pointer, 00h if not present
08h	8	Thermal Reference Data Address	Byte pointer, 00h if not present
09h	8	Feature Data Address	Byte pointer, 00h if not present
0Ah	8	Other Data Address	Byte pointer, 00h if not present
0Bh	16	Reserved	Reserved
0Dh	8	Checksum	1 byte checksum
Processor Data:			
0E - 13h	48	S-spec/QDF Number	Six 8-bit ASCII characters
14h	6 2	Reserved Sample/Production	Reserved (most significant bits) 00b = Sample only, 01-11b = Production
15h	8	Checksum	1 byte checksum
Processor Core Data:			
16 - 17h	2	Processor Core Type	From CPUID
	4	Processor Core Family	From CPUID
	4	Processor Core Model	From CPUID
	4	Processor Core Stepping	From CPUID
	2	Reserved	Reserved for future use
18 - 19h	16	Reserved	Reserved for future use
1A - 1Bh	16	Front Side Bus Speed	16-bit binary number (in MHz)
1Ch	2 6	Multiprocessor Support Reserved	00b = UP, 01b = DP, 10b = RSVD, 11b = MP Reserved
1D - 1Eh	16	Maximum Core Frequency	16-bit binary number (in MHz)
1F - 20h	16	Processor Core VID	V _{CC} requested by VID outputs in mV
21 - 22h	16	Core Voltage, Minimum	Minimum processor DC V _{CC} spec in mV

Table 8-2. Processor Information ROM Format (Sheet 2 of 2)

Offset/Section	# of Bits	Function	Notes
23h	8	T _{CASE} Maximum	Maximum case temperature spec in °C
24h	8	Checksum	1 byte checksum
Cache Data:			
25 - 26h	16	Reserved	Reserved
27 - 28h	16	L2 Cache Size	16-bit binary number (in KB)
29 - 2Ah	16	Reserved	Reserved
2B - 2Ch	16	Reserved	Reserved
2D - 2Eh	16	Reserved	Reserved
2F - 30h	16	Reserved	Reserved
31h	8	Checksum	1 byte checksum
Package Data:			
32 - 35h	32	Package Revision	Four 8-bit ASCII characters
36h	8	Reserved	Reserved
37h	8	Checksum	1 byte checksum
Part Number Data:			
38 - 3Eh	56	Processor Part Number	Seven 8-bit ASCII characters
3F - 4Ch	112	Reserved	Reserved
4D - 54h	64	Processor Electronic Signature	64-bit identification number
55 - 6Eh	208	Reserved	Reserved
6Fh	8	Checksum	1 byte checksum
Thermal Ref. Data:			
70h	8	Reserved	Reserved
71 - 72h	16	Reserved	Reserved
73h	8	Checksum	1 byte checksum
Feature Data:			
74 - 77h	32	Processor Core Feature Flags	From CPUID function 1, EDX contents
78h	8	Processor Feature Flags	[7] = Reserved [6] = Serial Signature [5] = Electronic Signature Present [4] = Thermal Sense Device Present [3] = Reserved [2] = OEM EEPROM Present [1] = Core VID Present [0] = Reserved
79-7Bh	24	Additional Processor Feature Flags	All bits Reserved
7Ch	8	Reserved	Reserved
7Dh	8	Checksum	1 byte checksum
Other Data:			
7E - 7Fh	16	Reserved	Reserved

8.4.2 Scratch EEPROM

Also available in the memory component on the processor SMBus is an EEPROM which may be used for other data at the system or processor vendor’s discretion. The data in this EEPROM, once programmed, can be write-protected by asserting the active-high SM_WP signal. This signal has a weak pull-down (10 kΩ) to allow the EEPROM to be programmed in systems with no implementation of this signal. The Scratch EEPROM resides in the upper half of the memory component (addresses 80 - FFh). The lower half comprises the Processor Information ROM (addresses 00 - 7Fh), which is permanently write-protected by Intel.

8.4.3 PIROM and Scratch EEPROM Supported SMBus Transactions

The Processor Information ROM (PIROM) responds to two SMBus packet types: Read Byte and Write Byte. However, since the PIROM is write-protected, it will acknowledge a Write Byte command but ignore the data. The Scratch EEPROM responds to Read Byte and Write Byte commands. Table 8-3 diagrams the Read Byte command. Table 8-4 diagrams the Write Byte command. Following a write cycle to the scratch ROM, software must allow a minimum of 10 ms before accessing either ROM of the processor.

In the tables, ‘S’ represents the SMBus start bit, ‘P’ represents a stop bit, ‘R’ represents a read bit, ‘W’ represents a write bit, ‘A’ represents an acknowledge (ACK), and ‘///’ represents a negative acknowledge (NACK). The shaded bits are transmitted by the Processor Information ROM or Scratch EEPROM, and the bits that aren’t shaded are transmitted by the SMBus host controller. In the tables, the data addresses indicate 8 bits. The SMBus host controller should transmit 8 bits with the most significant bit indicating which section of the EEPROM is to be addressed: the Processor Information ROM (MSB = 0) or the Scratch EEPROM (MSB = 1).

Table 8-3. Read Byte SMBus Packet

S	Slave Address	Write	A	Command Code	A	S	Slave Address	Read	A	Data	///	P
1	7-bits	1	1	8-bits	1	1	7-bits	1	1	8-bits	1	1

Table 8-4. Write Byte SMBus Packet

S	Slave Address	Write	A	Command Code	A	Data	A	P
1	7-bits	1	1	8-bits	1	8-bits	1	1

8.4.4 SMBus Thermal Sensor

The processor’s SMBus thermal sensor provides a means of acquiring thermal data from the processor. The thermal sensor is composed of control logic, SMBus interface logic, a precision analog-to-digital converter, and a precision current source. The sensor drives a small current through the p-n junction of a thermal diode located on the processor core. The forward bias voltage generated across the thermal diode is sensed and the precision A/D converter derives a single byte of thermal reference data, or a “thermal byte reading.” The nominal precision of the least significant bit of a thermal byte is 1°Celsius.

The processor incorporates the SMBus thermal sensor onto the processor package as was done on the Intel Xeon processor family. Upper and lower thermal reference thresholds can be individually programmed for the SMBus thermal sensor. Comparator circuits sample the register where the single byte of thermal data (thermal byte reading) is stored. These circuits compare the single-byte result against programmable threshold bytes. If enabled, the alert signal on the processor SMBus (SM_ALERT#) will be asserted when the sensor detects that either threshold is reached or crossed. Analysis of SMBus thermal sensor data may be useful in detecting changes in the system environment that may require attention.

The SMBus thermal sensor feature in the processor cannot be used to measure T_{CASE} . The T_{CASE} specification in [Section 7](#) must be met regardless of the reading of the processor's thermal sensor in order to ensure adequate cooling for the entire processor. The SMBus thermal sensor feature is only available while V_{CC} and SM_VCC are at valid levels and the processor is not in a low-power state.

8.4.5 Thermal Sensor Supported SMBus Transactions

The thermal sensor responds to five of the SMBus packet types: Write Byte, Read Byte, Send Byte, Receive Byte, and Alert Response Address (ARA). The Send Byte packet is used for sending one-shot commands only. The Receive Byte packet accesses the register commanded by the last Read Byte packet and can be used to continuously read from a register. If a Receive Byte packet was preceded by a Write Byte or send Byte packet more recently than a Read Byte packet, then the behavior is undefined. [Table 8-5](#) through [Table 8-9](#) diagram the five packet types. In these figures, 'S' represents the SMBus start bit, 'P' represents a stop bit, 'Ack' represents an acknowledge, and '///' represents a negative acknowledge (NACK). The shaded bits are transmitted by the thermal sensor, and the bits that aren't shaded are transmitted by the SMBus host controller. [Table 8-10](#) shows the encoding of the command byte.

Table 8-5. Write Byte SMBus Packet

S	Slave Address	Write	Ack	Command Code	Ack	Data	Ack	P
1	7-bits	1	1	8-bits	1	8-bits	1	1

Table 8-6. Read Byte SMBus Packet

S	Slave Address	Write	Ack	Command Code	Ack	S	Slave Address	Read	Ack	Data	///	P
1	7-bits	1	1	8-bits	1	1	7-bits	1	1	8-bits	1	1

Table 8-7. Send Byte SMBus Packet

S	Slave Address	Read	Ack	Command Code	Ack	P
1	7-bits	1	1	8-bits	1	1

Table 8-8. Receive Byte SMBus Packet

S	Slave Address	Read	Ack	Data	///	P
1	7-bits	1	1	8-bits	1	1

Table 8-9. ARA SMBus Packet

S	ARA	Read	Ack	Address	///	P
1	0001 100	1	1	Device Address ¹	1	1

NOTE:

1. This is an 8-bit field. The device which sent the alert will respond to the ARA Packet with its address in the seven most significant bits. The least significant bit is undefined and may return as a '1' or '0'. See [Section 8.4.8](#) for details on the Thermal Sensor Device addressing.

Table 8-10. SMBus Thermal Sensor Command Byte Bit Assignments

Register	Command	Reset State	Function
RESERVED	00h	RESERVED	Reserved for future use
TRR	01h	0000 0000	Read processor core thermal diode
RS	02h	N/A	Read status byte (flags, busy signal)
RC	03h	00XX XXXX	Read configuration byte
RCR	04h	0000 0010	Read conversion rate byte
RESERVED	05h	RESERVED	Reserved for future use
RESERVED	06h	RESERVED	Reserved for future use
RRHL	07h	0111 1111	Read processor core thermal diode T _{HIGH} limit
RRLl	08h	1100 1001	Read processor core thermal diode T _{LOW} limit
WC	09h	N/A	Write configuration byte
WCR	0Ah	N/A	Write conversion rate byte
RESERVED	0Bh	RESERVED	Reserved for future use
RESERVED	0Ch	RESERVED	Reserved for future use
WRHL	0Dh	N/A	Write processor core thermal diode T _{HIGH} limit
WRLL	0Eh	N/A	Write processor core thermal diode T _{LOW} limit
OSHT	0Fh	N/A	One shot command (use send byte packet)
RESERVED	10h – FFh	N/A	Reserved for future use

All of the commands in [Table 8-10](#) are for reading or writing registers in the SMBus thermal sensor, except the one-shot command (OSHT) register. The one-shot command forces the immediate start of a new conversion cycle. If a conversion is in progress when the one-shot command is received, then the command is ignored. If the thermal sensor is in stand-by mode when the one-shot command is received, a conversion is performed and the sensor returns to stand-by mode. The one-shot command is not supported when the thermal sensor is in auto-convert mode.

Note: Writing to a read-command register or reading from a write-command register will produce invalid results.

The default command after reset is to a reserved value (00h). After reset, Receive Byte SMBus packets will return invalid data until another command is sent to the thermal sensor.

8.4.6 SMBus Thermal Sensor Registers

8.4.6.1 Thermal Reference Registers

Once the SMBus thermal sensor reads the processor thermal diode, it performs an analog to digital conversion. The supported range is 0 to +127 decimal and is expressed as an eight-bit number representing temperature in degrees Celsius. This eight-bit value consists of seven bits of data and a sign bit (MSB) where the sign is always positive (sign = 0) and is shown in [Table 8-11](#). The values shown are also used to program the Thermal Limit Registers.

The values of these registers should be treated as saturating values. Values above 127 are represented at 127 decimal, and values of zero and below may be represented as 0 to -127 decimal. If the device returns a value where the sign bit is set (1) and the data is 000_0000 through 111_1110, the temperature should be interpreted as 0° Celsius.

Table 8-11. Thermal Reference Register Values

Temperature (°C)	Register Value (binary)
+127	0 111 1111
+126	0 111 1110
+100	0 110 0100
+50	0 011 0010
+25	0 001 1001
+1	0 000 0001
0	0 000 0000

8.4.6.2 Thermal Limit Registers

The SMBus thermal sensor has four Thermal Limit Registers:

- RRHL – used to read the high limit
- RRLl – used to read for the low limit
- WRHL – used to write the high limit
- WRLL – used to write the low limit

These registers allow the user to define high and low limits for the processor core thermal diode reading. The encoding for these registers is the same as for the TRR shown in [Table 8-11](#). If the processor thermal diode reading equals or exceeds one of these limits, then the alarm bit (RHIGH or RLOW) in the Thermal Sensor Status Register is triggered.

8.4.6.3 Status Register

The Status Register shown in [Table 8-12](#) indicates which, if any, thermal value thresholds for the processor core thermal diode have been exceeded. It also indicates whether a conversion is in progress or an open circuit has been detected in the processor core thermal diode connection. Once set, alarm bits stay set until they are cleared by a Status Register read. A successful read to the Status Register will clear any alarm bits that may have been set (unless the alarm condition persists). If the SM_ALERT# signal is enabled via the Thermal Sensor Configuration Register and a thermal diode threshold is exceeded, an alert will be sent to the platform via the SM_ALERT# signal.

This register is read by accessing the RS Command Register.

Table 8-12. SMBus Thermal Sensor Status Register

Bit	Name	Reset State	Function
7 (MSB)	BUSY	N/A	If set, indicates that the device's analog to digital converter is busy.
6	RESERVED	RESERVED	Reserved for future use.
5	RESERVED	RESERVED	Reserved for future use.
4	RHIGH	0	If set, indicates the processor core thermal diode high temperature alarm has activated.
3	RLOW	0	If set, indicates the processor core thermal diode low temperature alarm has activated.
2	OPEN	0	If set, indicates an open fault in the connection to the processor core diode.
1	RESERVED	RESERVED	Reserved for future use.
0 (LSB)	RESERVED	RESERVED	Reserved for future use.

8.4.6.4 Configuration Register

The Configuration Register controls the operating mode (stand-by vs. auto-convert) of the SMBus thermal sensor. Table 8-13 shows the format of the Configuration Register. If the RUN/STOP bit is set (high) then the thermal sensor immediately stops converting and enters stand-by mode. The thermal sensor will still perform analog to digital conversions in stand-by mode when it receives a one-shot command. If the RUN/STOP bit is clear (low), then the thermal sensor enters auto-conversion mode.

This register is accessed by using the thermal sensor Command Register. The RC command register is used for read commands and the WC command register is used for write commands. See Table 8-10.

Table 8-13. SMBus Thermal Sensor Configuration Register

Bit	Name	Reset State	Function
7 (MSB)	MASK	0	Mask SM_ALERT# bit. Clear the bit to allow interrupts via SM_ALERT# and allow the thermal sensor to respond to the ARA command when an alarm is active. Set the bit to disable interrupt mode. The bit is not used to clear the state of the SM_ALERT# output. An ARA command may not be recognized if the mask is enabled.
6	RUN/STOP	0	Stand-by mode control bit. If set, the device immediately stops converting, and enters stand-by mode. If cleared, the device converts in either one-shot mode or automatically updates on a timed basis.
5:0	RESERVED	RESERVED	Reserved for future use.

8.4.6.5 Conversion Rate Registers

The contents of the Conversion Rate Registers determine the nominal rate at which analog-to-digital conversions happen when the SMBus thermal sensor is in auto-convert mode. There are two Conversion Rate Registers: RCR for reading the conversion rate value; and WCR for writing the value. Table 8-14 shows the mapping between Conversion Rate Register values and the conversion

rate. As indicated in [Table 8-10](#), the Conversion Rate Register is set to its default state of 02h (0.25 Hz nominally) when the thermal sensor is powered up. There is a $\pm 30\%$ error tolerance between the conversion rate indicated in the conversion rate register and the actual conversion rate.

Table 8-14. SMBus Thermal Sensor Conversion Rate Registers

Register Value	Conversion Rate (Hz)
00h	0.0625
01h	0.125
02h	0.25
03h	0.5
04h	1.0
05h	2.0
06h	4.0
07h	8.0
08h to FFh	Reserved for future use

8.4.7 SMBus Thermal Sensor Alert Interrupt

The SMBus thermal sensor located on the processor includes the ability to interrupt the SMBus when a fault condition exists. The fault conditions consist of:

1. A processor thermal diode value measurement that exceeds a user-defined high or low threshold programmed into the Command Register; or
2. Disconnection of the processor thermal diode from the thermal sensor.

The interrupt can be enabled and disabled via the thermal sensor Configuration Register and is delivered to the system board via the SM_ALERT# open drain output. Once latched, the SM_ALERT# should only be cleared by reading the Alert Response byte from the Alert Response Address of the thermal sensor. The Alert Response Address is a special slave address shown in [Table 8-9](#). The SM_ALERT# will be cleared once the SMBus master device reads the slave ARA unless the fault condition persists. Reading the Status Register or setting the mask bit within the Configuration Register does not clear the interrupt.

8.4.8 SMBus Device Addressing

Of the addresses broadcast across the SMBus, the memory component claims those of the form “1010XXXZb”. The “XXX” bits are defined by pull-up and pull-down resistors on the system baseboard. These address pins are pulled down weakly (10 k Ω) on the processor substrate to ensure that the memory components are in a known state in systems which do not support the SMBus (or only support a partial implementation). The “Z” bit is the read/write bit for the serial bus transaction.

The thermal sensor internally decodes one of three upper address patterns from the bus of the form “0011XXXZb”, “1001XXXZb”, or “0101XXXZb”. The device’s addressing, as implemented, uses the SM_TS_A[1:0] pins in either the HI, LO, or Hi-Z state. Therefore, the thermal sensor supports nine unique addresses. To set either pin for the Hi-Z state, the pin must be left floating. As before, the “Z” bit is the read/write bit for the serial transaction.

Note that addresses of the form “0000XXXXb” are Reserved and should not be generated by an SMBus master. The thermal sensor samples and latches the SM_TS_A[1:0] signals at power-up and at the starting point of every conversion. System designers should ensure that these signals are at valid V_{IH} , V_{IL} , or floating input levels prior to or while the thermal sensor’s SM_VCC supply powers up. This should be done by pulling the pins to SM_VCC or V_{SS} via a 1 k Ω or smaller resistor, or leaving the pins floating to achieve the Hi-Z state. If the system designer wants to drive the SM_TS_A[1:0] pins with logic, the designer must still ensure that the pins are at valid input levels prior to or while the SM_VCC supply ramps up. The system designer must also ensure that their particular implementation does not add excessive capacitance to the address inputs. Excess capacitance at the address inputs may cause address recognition problems. Refer to the appropriate platform design guide document.

Figure 8-2 shows a logical diagram of the pin connections. Table 8-15 and Table 8-16 describe the address pin connections and how they affect the addressing of the devices.

Table 8-15. Thermal Sensor SMBus Addressing

Address (Hex)	Upper Address ¹	Device Select		8-bit Address Word on Serial Bus
		SM_TS_A1	SM_TS_A0	b[7:0]
3Xh	0011	0	0	0011000Xb
		Z ²	0	0011001Xb
		1	0	0011010Xb
5Xh	0101	0	Z ²	0101001Xb
		Z ²	Z ²	0101010Xb
		1	Z ²	0101011Xb
9Xh	1001	0	1	1001100Xb
		Z ²	1	1001101Xb
		1	1	1001110Xb

NOTES:

- Upper address bits are decoded in conjunction with the select pins.
- A tri-state or “Z” state on this pin is achieved by leaving this pin unconnected.

Note: System management software must be aware of the processor dependent addresses for the thermal sensor.

Table 8-16. Memory Device SMBus Addressing

Address (Hex)	Upper Address ¹	Device Select			R/W
		SM_EP_A2 bit 3	SM_EP_A1 bit 2	SM_EP_A0 bit 1	bit 0
A0h/A1h	1010	0	0	0	X
A2h/A3h	1010	0	0	1	X
A4h/A5h	1010	0	1	0	X
A6h/A7h	1010	0	1	1	X
A8h/A9h	1010	1	0	0	X
AAh/ABh	1010	1	0	1	X
ACh/ADh	1010	1	1	0	X
A Eh/AFh	1010	1	1	1	X

NOTE:

- This addressing scheme will support up to 8 processors on a single SMBus.

8.4.9 Managing Data in the PIROM

The PIROM consists of the following sections:

- Header
- Processor Data
- Processor Core Data
- Cache Data
- Package Data
- Part Number Data
- Thermal Reference Data
- Feature Data
- Other Data

Details on each of these sections are described below.

Note: Reserved fields or bits SHOULD be programmed to zeros. However, OEMs should not rely on this model.

8.4.9.1 Header

To maintain backward compatibility, the Header defines the starting address for each subsequent section of the PIROM. Software should check for the offset before reading data from a particular section of the ROM.

Example: Code looking for the cache data of a processor would read offset 05h to find a value of 25h. 25h is the first address within the 'Cache Data' section of the PIROM.

The Header also includes the data format revision at offset 0h and the EEPROM size (formatted in hex bytes) at offset 01-02h. The data format revision is used whenever fields within the PIROM are redefined. Normally the revision would begin at a value of 1. If a field, or bit assignment within a field, is changed such that software needs to discern between the old and new definition, then the data format revision field should be incremented.

The EEPROM size provides the size of the PIROM in hex bytes. The PIROM is 128 bytes; thus, offset 01 - 02h would be programmed to 80h.

8.4.9.2 Processor Data

This section contains two pieces of data:

- The S-spec/QDF of the part in ASCII format
- (1) 2-bit field to declare if the part is a pre-production sample or a production unit

The S-spec/QDF field is six ASCII characters wide and is programmed with the same S-spec/QDF value as marked on the processor. If the value is less than six characters in length, leading spaces (20h) are programmed in this field.

Example: A processor with a QDF mark of QEU5 contains the following in field 0E-13h: 20, 20, 51, 45, 55, 35h.

This data consists of two blanks at 0Eh and 0Fh followed by the ASCII codes for QEU5 in locations 10 - 13h.

Offset 14h contains the sample/production field, which is a two-bit field and is LSB aligned. All Q-spec material will use a value of 00b. All S-spec material will use a value of 01b. All other values are reserved.

Example: A processor with a Qxxx mark (engineering sample) will have offset 14h set to 00b. A processor with an Sxxxx mark (production unit) will use 01b at offset 14h.

8.4.9.3 Processor Core Data

This section contains core silicon-related data.

8.4.9.3.1 CPUID

The CPUID field is a copy of the results in EAX[13:0] from Function 1 of the CPUID instruction.

Note: The field is not aligned on a byte boundary since the first two bits of the offset are reserved. Thus, the data must be shifted right by two in order to obtain the same results.

Example: The CPUID of a C-1 stepping Intel® Xeon™ processor with 512 KB L2 cache is 0F27h. The value programmed into offset 16 - 17h of the PIROM is 3C9Ch.

Note: The first two bits of the PIROM are reserved, as highlighted in the example below.

CPUID instruction results	0000 1111 0010 0111 (0F27h)
PIROM content	0011 1100 1001 1100 (3C9Ch)

8.4.9.3.2 Front Side Bus Frequency

Offset 1A - 1Bh provides FSB frequency information. Systems may need to read this offset to decide if all installed processors support the same FSB speed. Because the Intel NetBurst microarchitecture bus is described as a 4x data bus, the frequency given in this field is currently 667 MHz. The data provided is the speed, rounded to a whole number, and reflected in hex.

Example: The 64-bit Intel® Xeon™ processor MP with 1MB L2 cache supports a 667 MHz FSB. Therefore, offset 1A - 1Bh has a value of 029Bh.

8.4.9.3.3 Multi-Processor Support

Offset 1Ch has 2 bits defined for representing the supported number of physical processors on the bus. These two bits are MSB aligned where 00b equates to single-processor operation, 01b is a dual-processor operation, and 11b represents multi-processor operation. Normally, only values of 01 and 11b are used. The remaining six bits in this field are reserved for the future use.

8.4.9.3.4 Maximum Core Frequency

Offset 1D - 1Eh provides the maximum core frequency for the processor. The frequency should equate to the markings on the processor and/or the QDF/S-spec speed even if the parts are not limited or locked to the intended speed. Format of this field is in MHz, rounded to a whole number, and encoded in hex format.

Example: A 2.8 GHz processor will have a value of 0AF0h, which equates to 2800 decimal.

8.4.9.3.5 Core Voltage

There are two areas defined in the PIROM for the core voltages associated with the processor. Offset 1F - 20h is the Processor Core VID (Voltage Identification) field and contains the voltage requested via the VID pins. In the case of the 64-bit Intel® Xeon™ processor MP with 1MB L2 cache, this is 1.2750 V. This field, rounded to the next thousandth, is in mV and is reflected in hex. This data is also in [Table 2-8](#). Some systems read this offset to determine if all processors support the same default VID setting.

Minimum core voltage is reflected in offset 21 – 22h. This field is in mV and reflected in hex. The minimum VCC reflected in this field is the minimum allowable voltage assuming the FMB maximum current draw.

Note: The minimum core voltage value in offset 21 – 22h is a single value that assumes the FMB maximum current draw. Refer to [Table 2-8](#) for the actual minimum core voltage specifications based on actual real-time current draw.

Example: The specifications for a 64-bit Intel® Xeon™ processor MP with 1MB L2 cache at FMB are 1.2750 V VID and 1.126 V minimum voltage. Offset 1F - 20h would contain 04FBh (1275 decimal) and offset 21 - 22h would contain 0466h (1126 decimal).

8.4.9.3.6 T_{CASE} Maximum

The last field within Processor Core Data is the T_{CASE} Maximum field. The field reflects temperature in degrees Celsius in hex format. This data can be found in the [Table 7-1](#). In the case of the 64-bit Intel® Xeon™ processor MP with 1MB L2 cache, the thermal specifications are specified at the case (IHS).

8.4.9.4 Cache Data

This section contains cache-related data.

8.4.9.4.1 L2 Cache Size

Offset 27 - 28h is the L2 cache size field. The field reflects the size of the level two cache in kilobytes.

Example: The 64-bit Intel® Xeon™ processor MP with 1MB L2 cache has a 1 MB (1024 KB) L2 cache. Thus, offset 27 - 28h will contain 0400h.

8.4.9.5 Package Data

This section describes the package revision location at offset 32 - 35h. This field tracks the highest level revision. It is provided in ASCII format of four characters (8 bits x 4 characters = 32 bits). The package is documented as 1.0, 2.0, etc. Because this only consumes three ASCII characters, a leading space is provided in the data field.

Example: The C-1 stepping of the Intel Xeon processor with 512 KB L2 cache is packaged in the 603-pin micro-PGA interposer with 31 mm OLGA package and utilizes the second revision of this package. Thus, at offset 32-35h the data is a space followed by 2.0. In hex, this would be 20, 32, 2E, 30.

8.4.9.6 Part Number Data

This section provides traceability. There are 208 available bytes in this section for future use.

8.4.9.6.1 Processor Part Number

Offset 38 - 3Eh contains seven ASCII characters reflecting the Intel part number for the processor. This information is typically marked on the outside of the processor. If the part number is less than 7 characters, a leading space is inserted into the value. The part number should match the information found in the marking specification found in [Section 4](#).

Example: The Intel Xeon processor with 512 KB L2 cache (533 MHz FSB) has a part number of 80532KE. Thus, the data found at offset 38 - 3Eh is 38, 30, 35, 33, 32, 4B, 45.

8.4.9.6.2 Processor Electronic Signature

Offset 4D - 54h contains a 64-bit identification number. Intel does not guarantee that each processor will have a unique value in this field.

8.4.9.7 Feature Data

This section provides information on key features that the platform may need to understand without powering on the processor.

8.4.9.7.1 Processor Core Feature Flags

Offset 74 - 77h contains a copy of results in EDX[31:0] from Function 1 of the CPUID instruction. These details provide instruction and feature support by product family.

8.4.9.7.2 Processor Feature Flags

Offset 78h provides additional feature information from the processor. This field is defined as follows:

Table 8-17. Offset 78h Definitions

Bit	Definition
7	Reserved
6	Serial signature (set if there is a serial signature at offset 4D - 54h)
5	Electronic signature present (set if there is a electronic signature at 4D - 54h)
4	Thermal Sense Device present (set if an SMBus thermal sensor on package)
3	Reserved
2	OEM EEPROM present (set if there is a scratch ROM at offset 80 - FFh)
1	Core VID present (set if there is a VID provided by the processor)
0	Reserved

8.4.9.7.3 Additional Processor Feature Flags

All bits of this field are reserved at this time. The field resides at offset 79 - 7Bh.

8.4.9.8 Other Data

Addresses 7E - 7F are listed as reserved.

8.4.9.9 Checksums

The PIROM includes multiple checksums. Table 8-18 includes the checksum values for each section defined in the 128 byte ROM, except Other Data.

Table 8-18. 128 Byte ROM Checksum Values

Section	Checksum Address
Header	0Dh
Processor Data	15h
Processor Core Data	24h
Cache Data	31h
Package Data	37h
Part Number Data	6Fh
Thermal Reference Data	73h
Feature Data	7Dh
Other Data	None Defined

Checksums are automatically calculated and programmed by Intel. The first step in calculating the checksum is to add each byte from the field to the next subsequent byte. This result is then negated to provide the checksum.

Example: For a byte string of AA445Ch, the resulting checksum will be B6h.

$$AA = 10101010 \quad 44 = 01000100 \quad 5C = 0101100$$

$$AA + 44 + 5C = 01001010$$

Negate the sum: $10110101 + 1 = \mathbf{101101 (B6h)}$

§

9 *Boxed Processor Specifications*

9.1 Introduction

The 64-bit Intel® Xeon™ processor MP with 1MB L2 cache will be offered as an Intel boxed processor. Intel boxed processors are intended for system integrators who build systems from components available through distribution channels. The boxed thermal solution is under development and is subject to change. This section is meant to provide some insight into the current direction of the thermal solution. Future revisions may have solutions that differ from those discussed here.

The current thermal solution plan for the boxed 64-bit Intel® Xeon™ processor MP with 1MB L2 cache is to include an unattached passive heatsink. This solution is currently targeted at chassis which are 3U and above in height.

This section documents baseboard and platform requirements for the thermal solution, supplied with the boxed 64-bit Intel® Xeon™ processor MP with 1MB L2 cache. This section is particularly important to companies that design and manufacture baseboards, chassis and complete systems. [Figure 9-1](#) shows the conceptual drawing of the boxed processor thermal solution.

Drawings in this section reflect only the specifications on the Intel boxed processor product. These dimensions should not be used as a generic keepout zone for all cooling solutions. It is the system designer's responsibility to consider their proprietary cooling solution when designing to the required keepout zone on their system platform and chassis.

Figure 9-1. Passive 64-bit Intel® Xeon™ Processor MP with 1MB L2 Cache Thermal Solution (3U and larger)

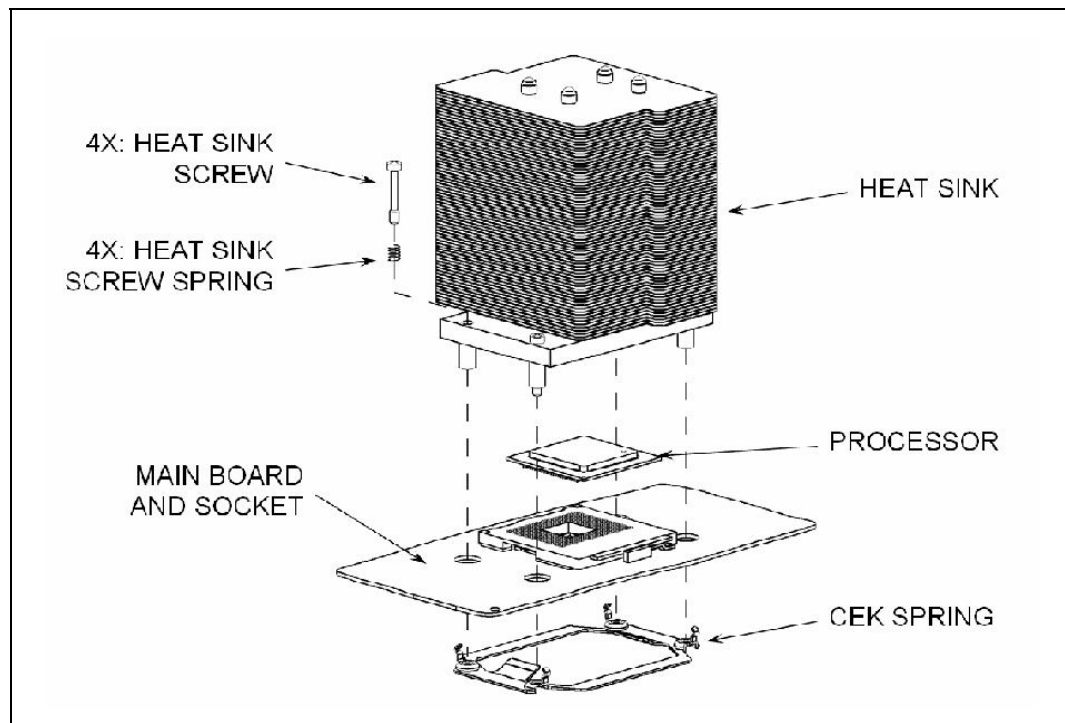

NOTE:

1. The heatsink in this image is for reference only.
2. This drawing shows the retention scheme for the boxed processor.

9.2 Mechanical Specifications

This section documents the mechanical specifications of the boxed processor passive heatsink.

9.2.1 Boxed Processor Heatsink Dimensions

The boxed processor is shipped with an unattached passive heatsink. Clearance is required around the heatsink to ensure unimpeded airflow for proper cooling. The physical space requirements and dimensions for the boxed processor and assembled heatsink are shown in the following figures.

Figure 9-2. Top Side Board Keepout Zones (Part 1)

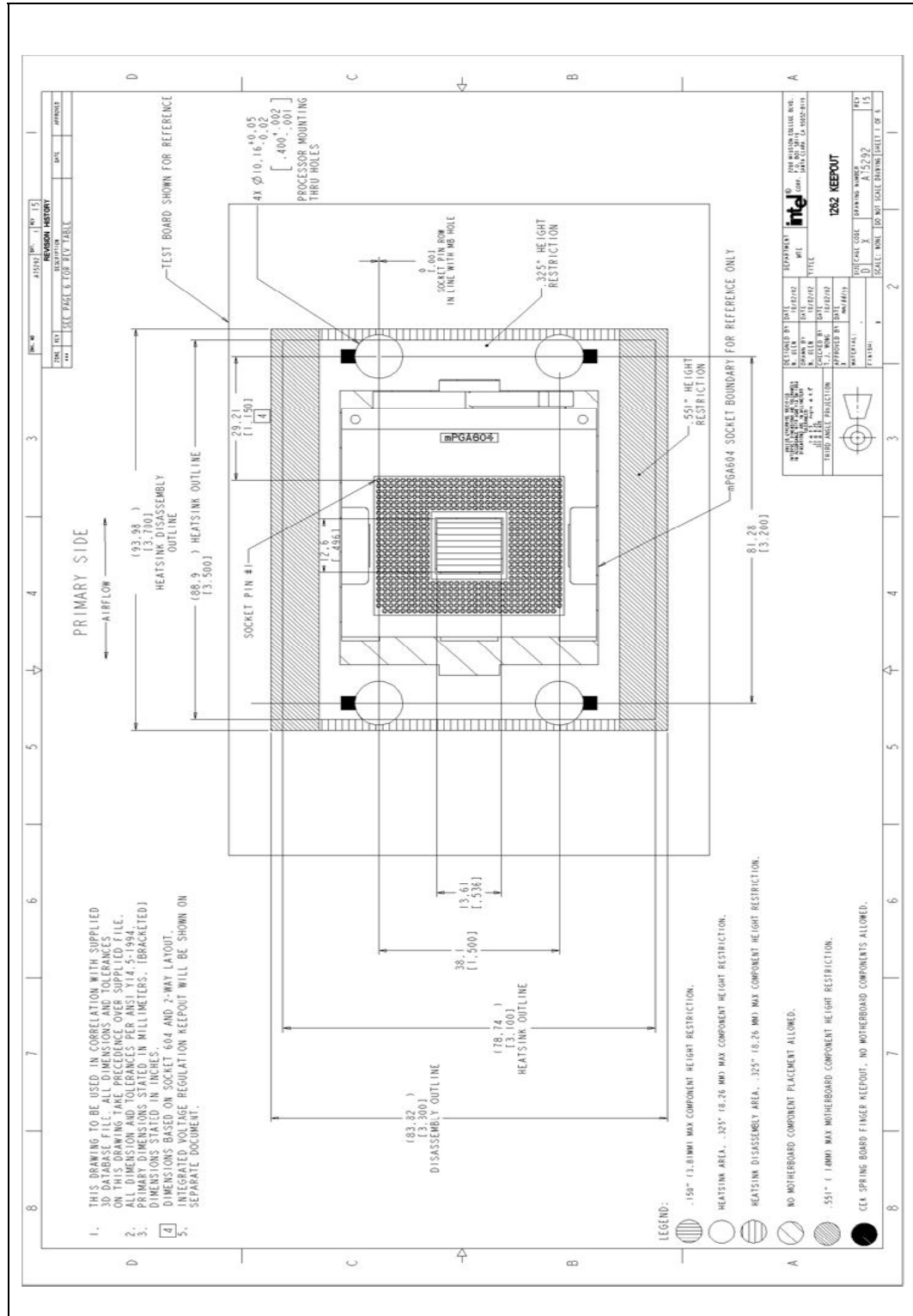

Figure 9-5. Board Mounting-Hole Keepout Zones

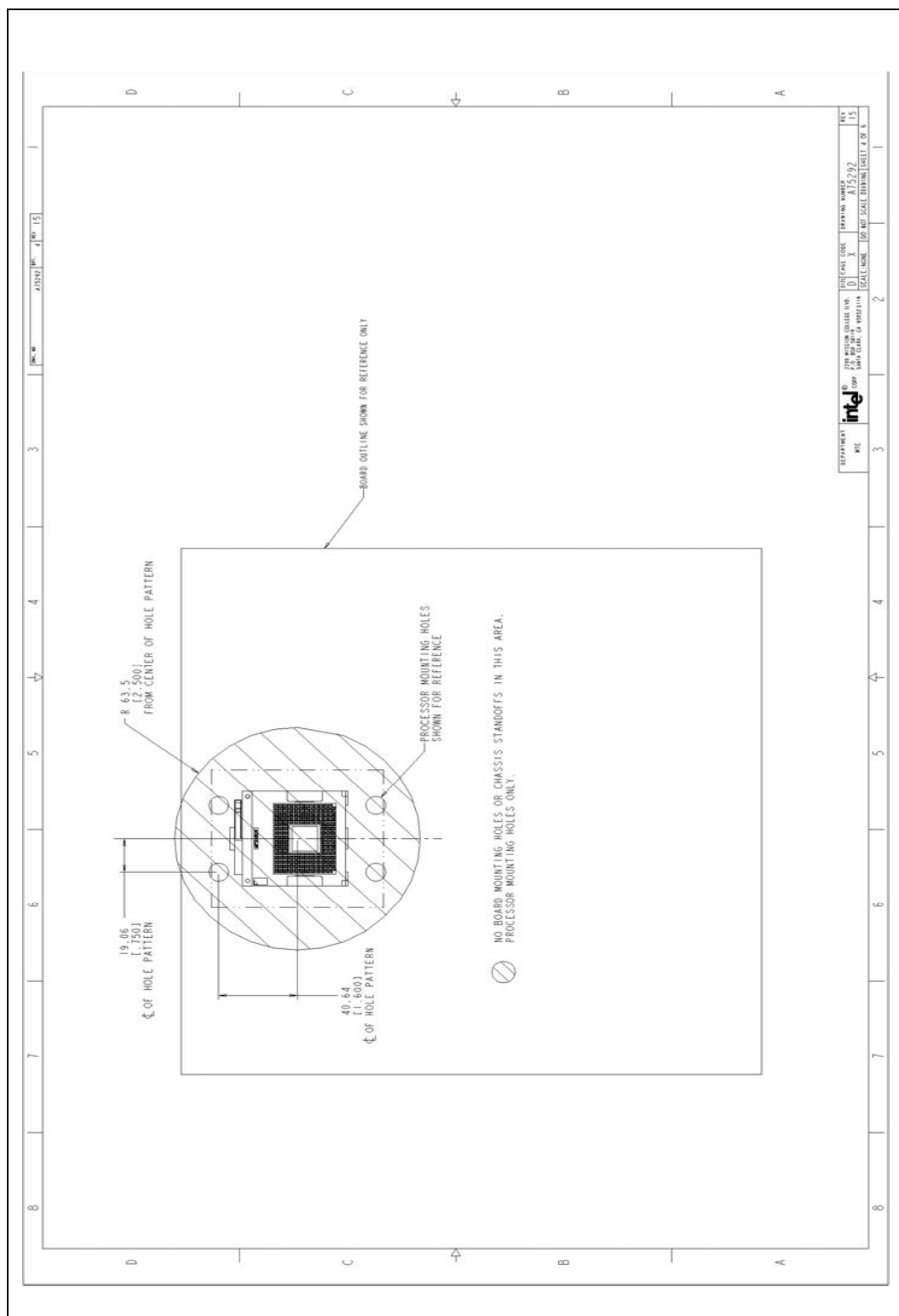

Figure 9-6. Thermal Solution Volumetric

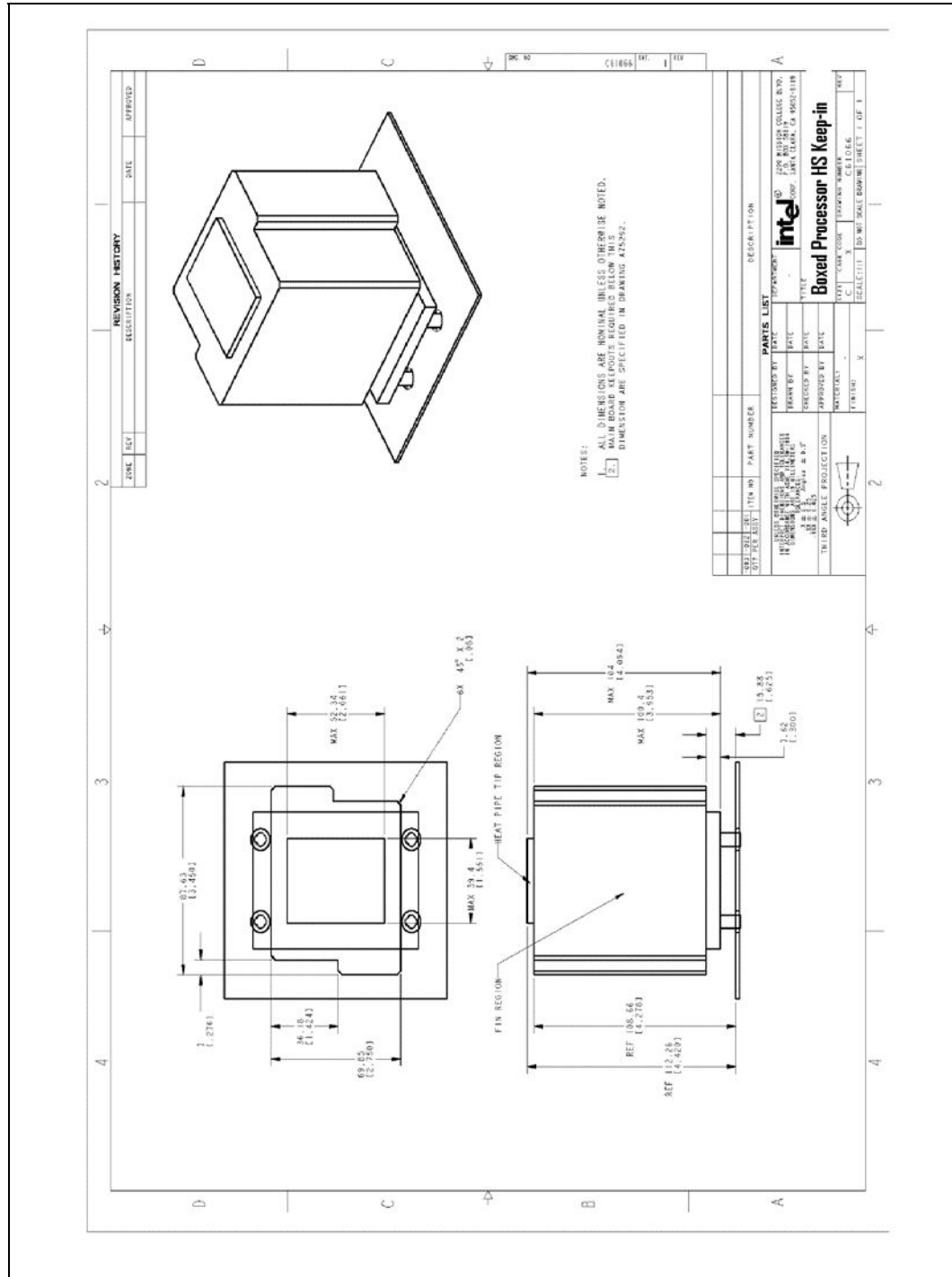
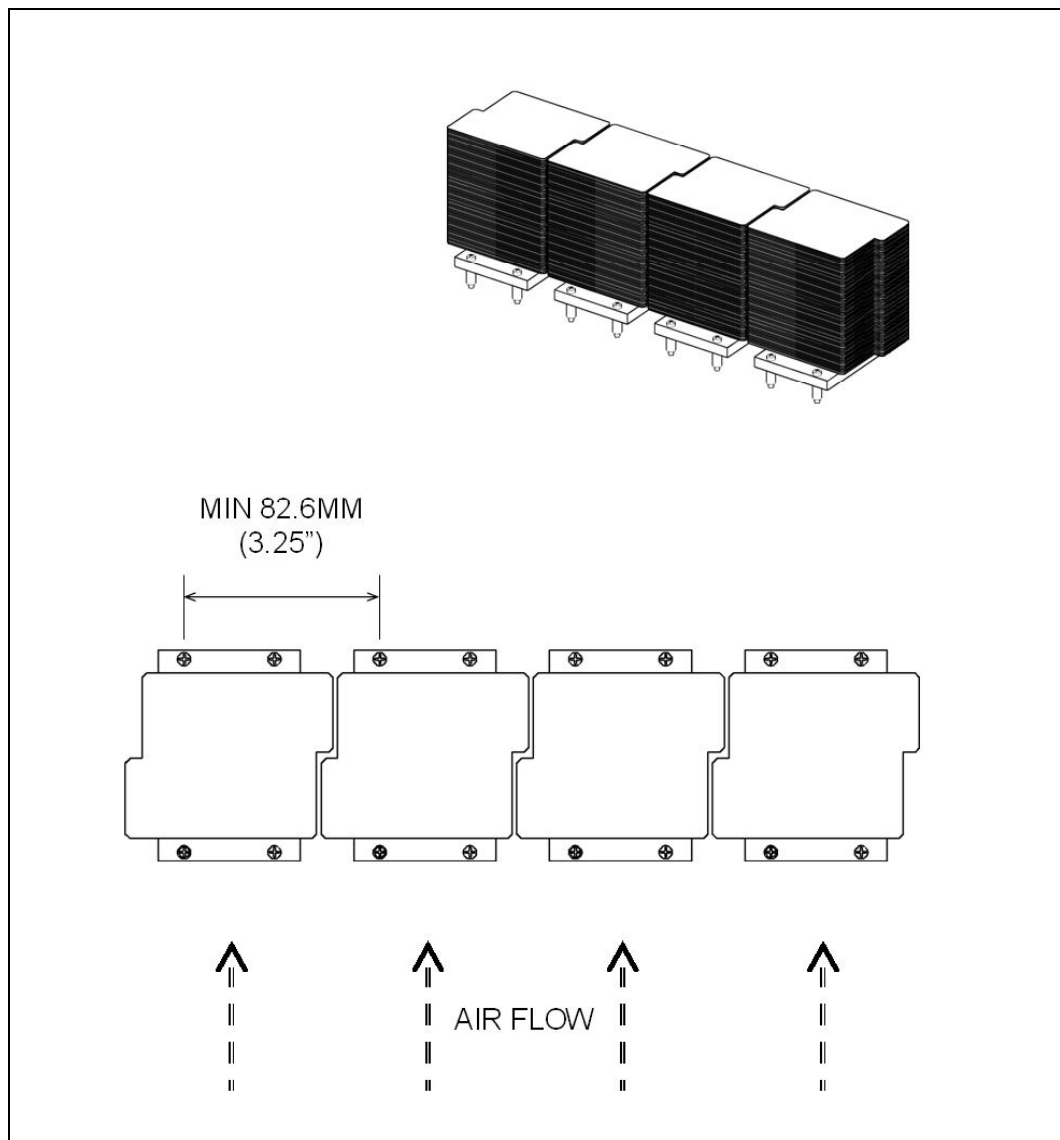

Figure 9-7. Recommended Processor Layout and Pitch



9.2.2 Boxed Processor Heatsink Weight

The boxed processor heatsink weight is approximately 530 grams. See [Section 4](#) of this document for details on the processor weight.

9.2.3 Boxed Processor Retention Mechanism and Heatsink Supports

Baseboards and chassis's designed for use by system integrators should include holes that are in proper alignment with each other to support the boxed processor. See [Figure 9-7](#) for example of processor pitch and layout.

[Figure 9-1](#) illustrates the new retention solution. This is designed to extend air-cooling capability through the use of larger heatsinks with minimal airflow blockage and minimal bypass. These retention mechanisms can allow the use of much heavier heatsink masses compared to legacy solution limitations by using a load path attached to the chassis pan. The hat spring on the under side of the baseboard provides the necessary compressive load for the thermal interface material. The baseboard is intended to be isolated such that the dynamic loads from the heatsink are transferred to the chassis pan via the heatsink screws and heatsink standoffs. This reduces the risk of package pullout and solder joint failures in a shock and vibrate situation.

The assembly requires larger diameter holes to compensate for the CEK spring embosses. See [Figure 9-2](#) and [Figure 9-3](#) for processor mounting through holes.

9.3 Thermal Specifications

This section describes the cooling requirements of the heatsink solution utilized by the boxed processor.

9.3.1 Boxed Processor Cooling Requirements

The boxed processor will be cooled by forcing ducted chassis fan airflow through the passive heatsink solution. Meeting the processor's temperature specifications is a function of the thermal design of the entire system, and ultimately the responsibility of the system integrator. The processor temperature specification is found in [Section 7](#) of this document. For the boxed processor passive heatsink to operate properly, chassis air movement devices are required. Necessary airflow and associated flow impedance is 23 cfm at 0.11" H₂O.

In addition, the processor pitch should be 3.25 inches, or slightly more, when placed in side by side orientation. [Figure 9-7](#) illustrates the side by side orientation and pitch. Note that the heatsinks are interleaved to reduce air bypass.

It is also recommended that the ambient air temperature outside of the chassis be kept at or below 35°C. The air passing directly over the processor heatsink should not be preheated by other system components (such as another processor), and should be kept at or below 40°C. Again, meeting the processor's temperature specification is the responsibility of the system integrator.

9.3.2 Boxed Processor Contents

The boxed processor will include the following items:

- 64-bit Intel® Xeon™ processor MP with 1MB L2 cache
- Unattached passive heatsink with captive screws
- Thermal interface material (pre-attached)
- Warranty/installation manual with Intel Inside logo

The other items required with this thermal solution should be shipped with either the chassis or the mainboard. They include:

- CEK spring (typically included with mainboard)
- Chassis standoffs
- System fans

§

10 *Debug Tools Specifications*

Please refer to the *eXtended Debug Port: Debug Port Design Guide for Intel® E8500 Chipset Platforms*, *eXtended Debug Port: Debug Port Design Guide for MP Platforms*, and the appropriate platform design guide for more detailed information regarding debug tools specifications.

10.1 **Logic Analyzer Interface (LAI)**

Intel is working with two logic analyzer vendors to provide logic analyzer interfaces (LAIs) for use in debugging 64-bit Intel® Xeon™ processor MP with 1MB L2 cache systems. Tektronix and Agilent should be contacted to get specific information about their logic analyzer interfaces. The following information is general in nature. Specific information must be obtained from the logic analyzer vendor.

Due to the complexity of 64-bit Intel® Xeon™ processor MP with 1MB L2 cache-based multiprocessor systems, the LAI is critical in providing the ability to probe and capture FSB signals. There are two sets of considerations to keep in mind when designing a 64-bit Intel® Xeon™ processor MP with 1MB L2 cache-based system that can make use of an LAI: mechanical and electrical.

10.1.1 **Mechanical Considerations**

The LAI is installed between the processor socket and the processor. The LAI pins plug into the socket, while the processor pins plug into a socket on the LAI. Cabling that is part of the LAI egresses the system to allow an electrical connection between the processor and a logic analyzer. The maximum volume occupied by the LAI, known as the keepout volume, as well as the cable egress restrictions, should be obtained from the logic analyzer vendor. System designers must make sure that the keepout volume remains unobstructed inside the system. Note that it is possible that the keepout volume reserved for the LAI may differ from the space normally occupied by the 64-bit Intel® Xeon™ processor MP with 1MB L2 cache heatsink. If this is the case, the logic analyzer vendor will provide a cooling solution as part of the LAI.

10.1.2 **Electrical Considerations**

The LAI will also affect the electrical performance of the FSB; therefore, it is critical to obtain electrical load models from each of the logic analyzer vendors to be able to run system level simulations to prove that their tool will work in the system. Contact the logic analyzer vendor for electrical specifications and load models for the LAI solution they provide.

§

