



Intel[®] 845 Family Chipset-Mobile: 82845MP/82845MZ Chipset Memory Controller Hub Mobile (MCH-M)

Datasheet

April 2002

Order Number: 250687-002



Information in this document is provided in connection with Intel products. No license, express or implied, by estoppel or otherwise, to any intellectual property rights is granted by this document. Except as provided in Intel's Terms and Conditions of Sale for such products, Intel assumes no liability whatsoever, and Intel disclaims any express or implied warranty, relating to sale and/or use of Intel products including liability or warranties relating to fitness for a particular purpose, merchantability, or infringement of any patent, copyright or other intellectual property right. Intel products are not intended for use in medical, life saving, or life sustaining applications.

Actual system-level properties, such as skin temperature, are a function of various factors, including component placement, component power characteristics, system power and thermal management techniques, software application usage and general system design. Intel is not responsible for its customers' system designs, nor is Intel responsible for ensuring that its customers' products comply with all applicable laws and regulations. Intel provides this and other thermal design information for informational purposes only. System design is the sole responsibility of Intel's customers, and Intel's customers should not rely on any Intel-provided information as either an endorsement or recommendation of any particular system design characteristics.

Intel may make changes to specifications and product descriptions at any time, without notice.

Designers must not rely on the absence or characteristics of any features or instructions marked "reserved" or "undefined." Intel reserves these for future definition and shall have no responsibility whatsoever for conflicts or incompatibilities arising from future changes to them.

The 845MP/845 MZ Memory Controller Hub (MCH-M) may contain design defects or errors known as errata which may cause the product to deviate from published specifications. Current characterized errata are available on request.

Contact your local Intel sales office or your distributor to obtain the latest specifications and before placing your product order.

I²C is a 2-wire communications bus/protocol developed by Philips. SMBus is a subset of the I²C bus/protocol and was developed by Intel. Implementations of the I²C bus/protocol may require licenses from various entities, including Philips Electronics N.V. and North American Philips Corporation.

Alert on LAN* is a result of the Intel-IBM Advanced Manageability Alliance and a trademark of IBM

Copies of documents which have an ordering number and are referenced in this document, or other Intel literature, may be obtained from:

Intel Corporation
www.intel.com
or call 1-800-548-4725

Intel®, Pentium®, and SpeedStep™ are registered trademarks or trademarks of Intel Corporation and its subsidiaries in the United States and other countries.

*Other brands and names may be claimed as the property of others.

Copyright © Intel Corporation 2002

Contents

1.	Overview	14
1.1.	System Architecture	15
1.2.	Mobile Intel Pentium® 4 Processor-M Host Interface	15
1.2.1.	System Bus Error Checking	16
1.3.	System Memory Interface	16
1.4.	AGP Interface	18
1.5.	Hub Interface	18
1.6.	MCH-M Clocking	18
1.7.	System Interrupts	19
2.	Signal Description	20
2.1.	Host Interface Signals	21
2.2.	DDR Interface	23
2.3.	Hub Interface Signals	24
2.4.	AGP Interface Signals	24
2.4.1.	AGP Addressing Signals	24
2.4.2.	AGP Flow Control Signals	25
2.4.3.	AGP Status Signals	25
2.4.4.	AGP Strobes	26
2.4.5.	AGP/PCI Signals-Semantics	27
2.5.	Clocks, Reset, and Miscellaneous	30
2.6.	Voltage References, PLL Power	31
2.7.	Pin State Table	31
3.	Register Description	36
3.1.	Conceptual Overview of the Platform Configuration Structure	36
3.2.	Standard PCI Bus Configuration Mechanism	36
3.3.	Routing Configuration Accesses	37
3.3.1.	PCI Bus #0 Configuration Mechanism	37
3.3.2.	Primary PCI and Downstream Configuration Mechanism	37
3.3.3.	AGP Configuration Mechanism	38
3.4.	MCH-M Register Introduction	38
3.5.	I/O Mapped Registers	39
3.5.1.	CONFIG_ADDRESS – Configuration Address Register	39
3.5.2.	CONFIG_DATA - Configuration Data Register	41
3.6.	Memory Mapped Register Space	42
3.6.1.	DRAMWIDTH—DRAM Width Register	43
3.6.2.	DQCMDSTR – Strength Control Register for DQ and CMD Signal Groups	44
3.6.3.	CKESTR – Strength Control Register for CKE Signal Group	45
3.6.4.	CSBSTR – Strength Control Register for CS# Signal Group	46
3.6.5.	CKSTR – Strength Control Register for CK Signal Group (CK / CK#)	47
3.6.6.	RCVENSTR – Strength Control Register for RCVENOUT# Signals	48
3.7.	Host-Hub Interface Bridge Device Registers – Device #0	48
3.7.1.	VID – Vendor Identification Register – Device#0	51
3.7.2.	DID – Device Identification Register – Device#0	51
3.7.3.	PCICMD – PCI Command Register – Device #0	52
3.7.4.	PCISTS – PCI Status Register – Device #0	53

3.7.5.	RID – Revision Identification Register – Device #0	54
3.7.6.	SUBC – Sub-Class Code Register – Device #0	54
3.7.7.	BCC – Base Class Code Register – Device #0	54
3.7.8.	MLT – Master Latency Timer Register – Device #0	55
3.7.9.	HDR – Header Type Register – Device #0	55
3.7.10.	APBASE – Aperture Base Configuration Register – Device #0	56
3.7.11.	SVID – Subsystem Vendor ID – Device #0	57
3.7.12.	SID – Subsystem ID – Device #0	57
3.7.13.	CAPPTR – Capabilities Pointer – Device #0	57
3.7.14.	AGPM- AGP Miscellaneous Configuration	58
3.7.15.	DRB[0:7] – DRAM Row Boundary Registers – Device #0	58
3.7.16.	DRA[0:7] – DRAM Row Attribute Registers – Device #0	59
3.7.17.	DRT – DRAM Timing Register – Device #0	60
3.7.18.	DRC – DRAM Controller Mode Register – Device #0	61
3.7.19.	DERRSYN – DRAM Error Syndrome Register	63
3.7.20.	EAP – Error Address Pointer Register – Device #0	63
3.7.21.	PAM[0:6] – Programmable Attribute Map Registers – Device #0	64
3.7.22.	FDHC – Fixed DRAM Hole Control Register – Device #0	68
3.7.23.	SMRAM – System Management RAM Control Register – Device #0	69
3.7.24.	ESMRAMC – Extended System Mgmt RAM Control Register – Device #0	70
3.7.25.	ACAPID – AGP Capability Identifier Register – Device #0	71
3.7.26.	AGPSTAT – AGP Status Register – Device #0	72
3.7.27.	AGPCMD – AGP Command Register – Device #0	73
3.7.28.	AGPCTRL – AGP Control Register	74
3.7.29.	APSIZE – Aperture Size – Device #0	75
3.7.30.	ATTBASE – Aperture Translation Table Base Register – Device #0	76
3.7.31.	AMTT – AGP Interface Multi-Transaction Timer Register – Device #0	77
3.7.32.	LPTT – AGP Low Priority Transaction Timer Register – Device #0	78
3.7.33.	TOM – Top of Low Memory Register – Device #0	79
3.7.34.	MCH-MCFG – MCH-M Configuration Register – Device #0	80
3.7.35.	ERRSTS – Error Status Register – Device #0	81
3.7.36.	ERRCMD – Error Command Register – Device #0	82
3.7.37.	SMICMD – SMI Command Register – Device #0	83
3.7.38.	SCICMD – SCI Command Register – Device #0	83
3.7.39.	SKPD – Scratchpad Data – Device #0	84
3.7.40.	CAPID – Product Specific Capability Identifier	84
3.8.	AGP Bridge Registers – Device #1	85
3.8.1.	VID1 – Vendor Identification Register – Device #1	87
3.8.2.	DID1 – Device Identification Register – Device #1	87
3.8.3.	PCICMD1 – PCI-PCI Command Register – Device #1	88
3.8.4.	PCISTS1 – PCI-PCI Status Register – Device #1	89
3.8.5.	RID1 – Revision Identification Register – Device #1	90
3.8.6.	SUBC1- Sub-Class Code Register – Device #1	90
3.8.7.	BCC1 – Base Class Code Register – Device #1	91
3.8.8.	MLT1 – Master Latency Timer Register – Device #1	91
3.8.9.	HDR1 – Header Type Register – Device #1	91
3.8.10.	PBUSN1 – Primary Bus Number Register – Device #1	92
3.8.11.	SBUSN1 – Secondary Bus Number Register – Device #1	92
3.8.12.	SUBUSN1 – Subordinate Bus Number Register – Device #1	92
3.8.13.	SMLT1 – Secondary Master Latency Timer Register – Device #1	93
3.8.14.	IOBASE1 – I/O Base Address Register – Device #1	94
3.8.15.	IOLIMIT1 – I/O Limit Address Register – Device #1	94
3.8.16.	SSTS1 – Secondary PCI-PCI Status Register – Device #1	95

3.8.17.	MBASE1 – Memory Base Address Register – Device #1	96
3.8.18.	MLIMIT1 – Memory Limit Address Register – Device #1	97
3.8.19.	PMBASE1 – Prefetchable Memory Base Address Register – Device #1 ...	98
3.8.20.	PMLIMIT1 – Prefetchable Memory Limit Address Register – Device #1 ...	99
3.8.21.	BCTRL1 – PCI-PCI Bridge Control Register – Device #1	100
3.8.22.	ERRCMD1 – Error Command Register – Device #1	101
3.8.23.	DWTMC – DRAM Write Thermal Management Control	102
3.8.24.	DRTMC – DRAM Read Thermal Management Control	104
4.	System Address Map	105
4.1.	Memory Address Ranges	105
4.1.1.	VGA and MDA Memory Space	106
4.1.2.	PAM Memory Spaces	107
4.1.3.	ISA Hole Memory Space	108
4.1.4.	TSEG SMM Memory Space	108
4.1.5.	System Bus Interrupt APIC Memory Space	109
4.1.6.	High SMM Memory Space	109
4.1.7.	AGP Aperture Space (Device #0 BAR)	109
4.1.8.	AGP Memory and Prefetchable Memory	109
4.1.9.	Hub Interface A Subtractive Decode	110
4.2.	AGP Memory Address Ranges	110
4.2.1.	AGP DRAM Graphics Aperture	110
4.3.	System Management Mode (SMM) Memory Range	111
4.3.1.	SMM Space Definition	111
4.3.2.	SMM Space Restrictions	112
4.4.	I/O Address Space	112
4.5.	MCH-M Decode Rules and Cross-Bridge Address Mapping	112
4.5.1.	Decode Rules for the Hub Interface A	112
4.5.2.	AGP Interface Decode Rules	113
5.	Functional Description	114
5.1.	Host Interface Overview	114
5.1.1.	Dynamic Bus Inversion	114
5.1.2.	System Bus Interrupt Delivery	114
5.1.3.	Upstream Interrupt Messages	115
5.2.	System Memory Interface	115
5.2.1.	DDR Interface Overview	115
5.2.2.	Memory Organization and Configuration	116
5.2.2.1.	Configuration Mechanism for SO-DIMMs	116
5.2.2.1.1.	Memory Detection and Initialization	116
5.2.2.1.2.	SMBus Configuration and Access of the Serial Presence Detect Ports	116
5.2.2.1.3.	Memory Register Programming	116
5.2.3.	DRAM Performance Description	117
5.2.3.1.	Data Integrity (ECC)	117
5.3.	AGP Interface Overview	117
5.3.1.	AGP Target Operations	118
5.3.2.	AGP Transaction Ordering	119
5.3.3.	AGP Signal Levels	119
5.3.4.	4x AGP Protocol	119
5.3.5.	Fast Writes	119
5.3.6.	AGP FRAME# Transactions on AGP	120

5.3.6.1.	MCH-M Target and Initiator Operations for AGP FRAME# Transactions	120
5.4.	Power and Thermal Management	122
5.4.1.	Various States	123
5.4.2.	General Description of Supported CPU States	123
5.4.3.	General Description of ACPI System States	124
5.4.4.	Power Transitions.....	124
5.4.5.	Intel SpeedStep® Technology.....	125
5.5.	MCH-M Clocking	125
5.6.	MCH-M System Reset and Power Sequencing.....	125
6.	Electrical Characteristics.....	126
6.1.	Absolute Maximum Ratings.....	126
6.2.	Thermal Characteristics	126
6.3.	Power Characteristics	127
7.	Signal Groups	128
8.	DC Characteristics	130
9.	Ballout and Package Information	133
9.1.	Ballout Diagram	133
9.2.	Ballout Table.....	135
9.3.	Package Mechanical Information	139
9.4.	Testability	143
9.4.1.	XOR Test Mode Initialization.....	143
9.4.2.	XOR Chains	144

Figures

Figure 1. Intel® 845MP/845MZ Chipset System Block Diagram	14
Figure 2. Configuration Address Register	39
Figure 3. Configuration Data Register.....	41
Figure 4. PAM Register Attributes.....	66
Figure 5. Addressable Memory Space.....	105
Figure 6. Detailed DOS Compatible Area Address Map.....	106
Figure 7. Detailed Extended Memory Range Address Map.....	108
Figure 8. MCH-M BGA Package Dimensions (Top View).....	139
Figure 9. MCH-M BGA Package Dimensions (Side View).....	140
Figure 10. MCH-M BGA Package Dimensions (Bottom View)	141
Figure 11. XOR-Tree Chain	143

Tables

Table 1. DDR Memory Capacity	16
Table 2. DDR Device Configurations	17
Table 3. MCH-M Clock Ratio Table	19
Table 4. Host Interface Signal Descriptions	21
Table 5. DDR Interface Signal Descriptions	23
Table 6. Hub Interface Signal Descriptions	24
Table 7. AGP Addressing Signal Descriptions	24
Table 8. AGP Flow Control Signal Descriptions	25
Table 9. AGP Status Signal Descriptions	25
Table 10. AGP Strobe Descriptions	26
Table 11. AGP/PCI Signal Semantics Descriptions	27
Table 12. Clocks, Reset, and Miscellaneous Descriptions	30
Table 13. Voltage Reference Descriptions	31
Table 14. Host Signals	32
Table 15. DDR Signals	33
Table 16. AGP Signals	34
Table 17. Clock/Miscellaneous Signals	35
Table 18. Hub Interface Signals	35
Table 19. Device Number Assignment	36
Table 20. Nomenclature for Access Attributes	48
Table 21. MCH-M Configuration Space for Device #0	49
Table 22. Control Signals for Various Memory Segments	65
Table 23. PAM Register Details	67
Table 24. Nomenclature for Access Attributes	85
Table 25. MCH-M Configuration Space - Device #1	85
Table 26. SMM Space	111
Table 27. Relation of DBI Bits to Data Bits	114
Table 28. Data Bytes on SO-DIMM Used for Programming DRAM Registers	117
Table 29. AGP Commands Supported by the MCH-M When Acting as an AGP Target	118
Table 30. Fast Write Initialization	120
Table 31. PCI Commands Supported by the MCH-M When Acting as a FRAME# Target	120
Table 32. Power Management State Combinations	123
Table 33. Intel 845MP/845MZ Power Transitions	124
Table 34. Absolute Maximum Ratings	126
Table 35. Intel 845MP/845MZ Chipset MCH-M Package Thermal Resistance	126
Table 36. Power Characteristics	127
Table 37. Signal Groups	128
Table 38. DC Characteristics	130
Table 39. Top View (Left Side)	133
Table 40. Top View (Right Side)	134
Table 41. FCBGA Handling Zone Description	142
Table 42. XOR Chains	144

Revision History

Rev.	Description	Date
001	Initial release	March 2002
002	Included 845MZ data	April 2002

Reference Documents

Document	Document Number/Location
<i>Mobile Intel® Pentium® 4 Processor-M and Intel® 845MP/845MZ Chipset Platform Design Guide</i>	www.developer.intel.com
<i>Intel® 82801CAM I/O Controller Hub 3 (ICH3-M) Datasheet</i>	www.developer.intel.com
<i>Intel® DDR200 JEDEC Specification Addendum, Revision 1.0</i>	www.developer.intel.com
<i>Intel® DDR266 JEDEC Specification Addendum, Revision 0.9</i>	www.developer.intel.com
<i>JEDEC Double Data Rate (DDR) SDRAM Specification, Revision 2.0</i>	www.jedec.org
<i>JEDEC PC2100 DDR SDRAM Un-buffered SO-DIMM Reference Design Specification (includes PC1600 DDR SDRAM)</i>	www.jedec.org
<i>Accelerated Graphics Port Interface Specification Rev 2.0</i>	http://www.agpforum.org/
<i>PCI Local Bus Specification Rev. 2.1</i>	www.pcisig.com
<i>PCI-PCI Bridge Specification Rev. 1.0</i>	www.pcisig.com
<i>PCI Bus Power Management Interface Specification Rev. 1.0</i>	www.pcisig.com
<i>Advanced Configuration and Power Interface Specification (ACPI) Rev. 1.0b</i>	www.teleport.com/~acpi/

Note: See *Mobile Intel® Pentium® 4 Processor-M and Intel® 845MP/845MZ Chipset Platform Design Guide* for an expanded set of related documents.

Terminology

MCH-M - The Mobile Memory Controller Hub-M component that contains the processor interface, DRAM controller, and AGP interface. It communicates with the I/O controller hub (ICH3-M) and other IO controller hubs over proprietary interconnect called the hub interface.

ICH3-M - The Mobile I/O Controller Hub 3-M component that contains the primary PCI interface, LPC interface, USB, ATA-100, AC'97, and other IO functions. It communicates with the Intel® 845MP/845MZ Chipset MCH-M over a proprietary interconnect called hub interface.

Host - This term is used synonymously with processor.

Core - The internal base logic in the MCH-M.

System Bus - Processor-to-MCH-M interface. The Enhanced Mode of the Scalable Bus is the P6 Bus plus enhancements, consisting of source synchronous transfers for address and data, and system bus interrupt delivery. The Mobile Intel Pentium 4 Processor-M implements a subset of Enhanced Mode.

Hub interface - The proprietary hub interconnect that ties the MCH-M to the ICH3-M. In this document hub interface cycles originating from or destined for the primary PCI interface on the ICH3-M is generally referred to as hub interface cycles.

Accelerated Graphics Port (AGP) - Refers to the AGP interface that is in the MCH-M. It supports AGP 2.0 compliant components only with 1.5V signaling level. PIPE# and SBA addressing cycles and their associated data phases are generally referred to as AGP transactions. FRAME# cycles over the AGP bus are generally referred to as AGP/PCI transactions.

PCI_A - The physical PCI bus, driven directly by the ICH3-M component. It supports 5-V, 32-bit, 33-MHz PCI 2.2 compliant components. Communication between PCI_A and MCH-M occurs over hub interface. Note: Even though it is referred to as PCI_A it is not PCI Bus #0 from a configuration standpoint.

Full Reset - A Full MCH-M Reset is defined in this document when RSTIN# is asserted.

System Bus - Synonymous with Host or Front Side Bus

GART - Graphics Aperture Re-map Table. This table contains the page re-map information used during AGP aperture address translations.

GTLB - Graphics Translation Look-aside Buffer. A cache used to store frequently used GART entries.

UP – Uniprocessor

DBI – Dynamic Bus inversion

MSI – Message Signaled Interrupts. MSI's allow a device to request interrupt service via a standard Memory Write transaction instead of through a hardware signal.

IPI – Inter Processor Interrupt

Word – 16 bits = 2 bytes

Dword (DW) – Doubleword: 32bits = 4 bytes

Qword (QW) – Quadword: 8bytes = 4 words

DQword (DQW) – Double Quadword: 16 bytes or 8 words. This is sometimes referred to as a Superword (SW of Sword), and is also referred to as a “Cache Line”.

Intel® 845 Chipset MCH-M Features

- Processor/Host Bus Support
 - Supports the Mobile Intel Pentium 4 Processor-M CPU
 - Supports the Intel Pentium® 4 processor subset of the Enhanced Mode Scalable Bus Protocol
 - 2x Address, 4x Data
 - Mobile Intel Pentium 4 Processor-M System Bus interrupt delivery
 - Supports system bus at 400 MT/s (100 MHz)
 - Supports host bus Dynamic Bus Inversion (DBI)
 - Supports 32-bit host bus addressing
 - 12 deep In-Order Queue
 - AGTL+ bus driver technology with integrated AGTL termination resistors
- Memory System
 - Directly supports one DDR channel, 64b wide (72b with ECC).
 - Supports 200 and 266-MHz DDR compliant devices (845MZ supports 200 MHz DDR only)
 - Supports 64-Mb, 128-Mb, 256-Mb and 512-Mb technologies for x16 devices and x8 devices.
 - All supported devices have 4 banks
 - Configurable optional ECC operation (single bit Error Correction and multiple bit Error Detection)
 - Supports up to 16 simultaneous open pages
 - Supports page sizes of 2 KB, 4 KB, 8 KB, and 16 KB. Page size is individually selected for every row.
 - Thermal throttling scheme to selectively throttle reads and/or writes. Throttling can be triggered by preset read/write bandwidth limits.
 - Max of 2 double-sided (4 rows populated) with unbuffered PC2100 DDR (with or without ECC) SO-DIMMs (845MZ supports only 200-MHz DDR).
 - Largest memory supported is 1 GB (845MZ supports only up to 512 MB).
- System Interrupts
 - Supports only System Bus interrupt delivery mechanism
 - Supports interrupts signaled as upstream Memory Writes from AGP/PCI (PCI semantics only) and hub interface
 - MSI direct to the System Bus
 - Supports peer MSI between hub interface and AGP
 - Provides redirection for IPI and upstream interrupts to the System Bus
- Accelerated Graphics Port (AGP) Interface
 - Supports a single AGP device (either a connector or on the motherboard)
 - AGP Support
 - Supports AGP 2.0 including 1x, 2x, and 4x AGP data transfers and 2x/4x Fast Write protocol
 - Supports only 1.5-V AGP electricals
 - 32 deep AGP request queue
 - PCI semantic (FRAME# initiated) accesses to DRAM are snooped
 - High priority access support
 - Hierarchical PCI configuration mechanism
 - Delayed transaction support for AGP-to-DRAM FRAME# semantic reads that can not be serviced immediately
 - 32-bit upstream address support for inbound AGP and PCI cycles
 - 32-bit downstream address support for outbound PCI and Fast Write cycles
 - AGP Busy/Stop Protocol
 - AGP Clamping and Sense Amp Control
- Hub Interface to ICH3-M
 - 266-MB/s, point-to-point hub interface to ICH3-M
 - 66-MHz base clock
 - Supports the following traffic types to the ICH3-M
 - Hub interface-to-AGP memory writes
 - Hub interface-to-DRAM
 - CPU-to-hub interface
 - Messaging
 - MSI Interrupt messages
 - Power Management state change
 - SMI, SCI and SERR error indication
- Power Management
 - SMRAM space remapping to A0000h (128 KB)
 - Supports extended SMRAM space above 256 MB, additional 128K/256K/512K TSEG from Top of Memory, cacheable (cacheability controlled by CPU)
 - APM Rev 1.2 compliant power management
 - Suspend to System Memory
 - ACPI 2.0 Support
 - Intel SpeedStep™ technology support
 - Cache coherency with CPU in sleep mode
 - Dynamic Memory Power-down
- Package
 - Package options
 - 593-pin FC-BGA (37.5 x 37.5 mm)

1. Overview

Figure 1. Intel® 845MP/845MZ Chipset System Block Diagram

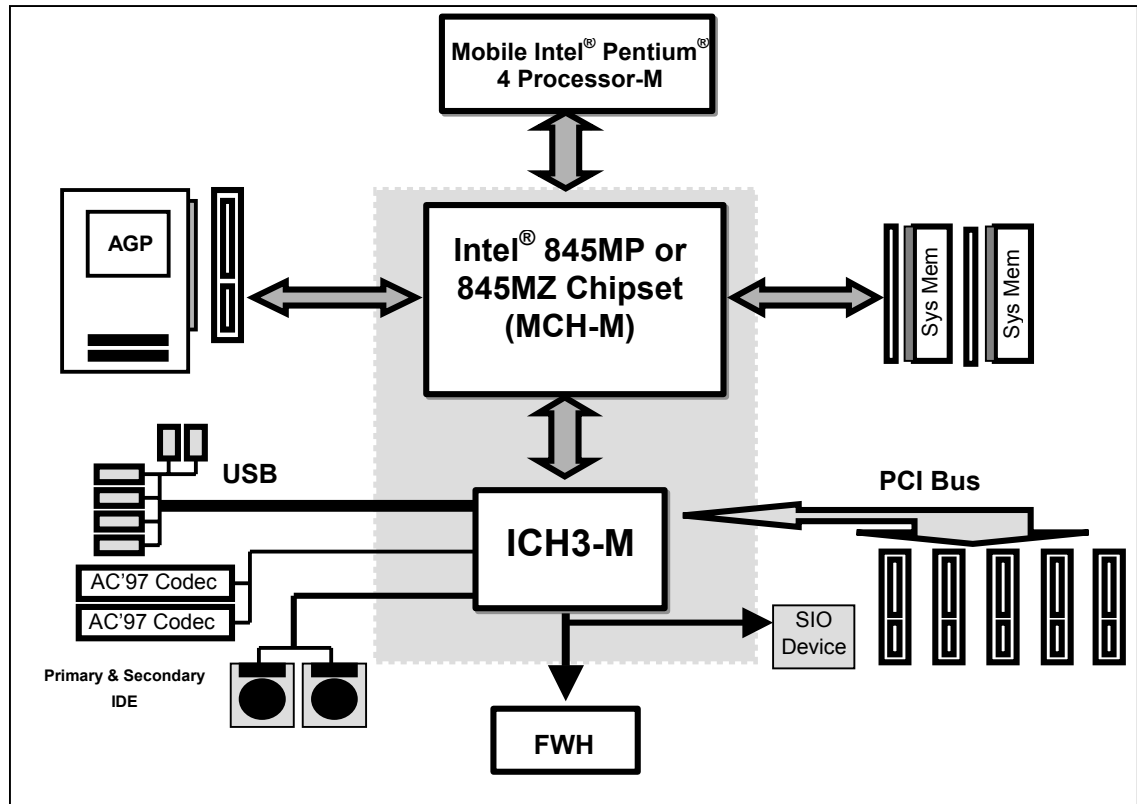

The Intel 845MP/845MZ Chipset Memory Controller Hub-M (MCH-M) is designed for use with the Mobile Intel Pentium 4 Processor-M. The Intel 845MP/845MZ Chipset MCH-M manages the flow of information between its four interfaces: the System Bus, the memory interface, the AGP port, and the hub interface. The MCH-M arbitrates between the four interfaces when each initiates an operation. While doing so, the MCH-M must support data coherency via snooping and must perform address translation for access to AGP Aperture memory.

The Intel 845MP/845MZ Chipset Memory Controller Hub-M (MCH-M) may contain design defects or errors known as errata, which may cause the product to deviate from published specifications.

1.1. System Architecture

The Intel 845MP/845MZ Chipset Memory Controller Hub-M (MCH-M) component provides the processor interface, DRAM interface, AGP interface, and hub interface. The CPU interface supports the Mobile Intel Pentium 4 Processor-M subset of the Extended Mode of the Scalable Bus Protocol. The Intel 845MP/845MZ Chipset is optimized for the Mobile Intel Pentium 4 Processor-M. It supports a single channel of DDR memory. The MCH-M contains advanced power management logic. The Intel 845MP/845MZ Chipset platform supports the third generation mobile I/O Controller Hub (ICH3-M) to provide the features required by a mobile platform.

The Intel 845 Chipset-Mobile Family (MCH-M) is in a 593-pin FC-BGA package and contains the following functionality:

- Supports single Mobile Intel Pentium 4 Processor-M configurations at 400 MT/s
- AGTL+ host bus with integrated termination supporting 32-bit host addressing
- 845MP supports up to 1 GB of PC2100 Memory
- 845MZ supports up to 512 MB of PC1600 Memory
- 1.5-V AGP interface with 4x SBA/PIPE# Data Transfer and Fast Write capability
- 1.8-V, 8-bit, 66-MHz 4x hub interface to ICH3-M
- Deeper Sleep
- Intel SpeedStep® technology
- Distributed arbitration for highly concurrent operation

1.2. Mobile Intel Pentium® 4 Processor-M Host Interface

The Intel 845MP/845MZ Chipset MCH-M is optimized for the Mobile Intel Pentium 4 Processor-M. The primary enhancements over the Compatible Mode P6 bus protocol are:

- Source synchronous double pumped address
- Source synchronous quad pumped data
- System bus interrupt and side-band signal delivery

In this mode, the MCH-M supports a 64B cache line size. Only one processor is supported at a System bus frequency of 400 MT/s. The MCH-M integrates AGTL+ termination resistors on all of the AGTL+ signals. The MCH-M supports 32-bit host addresses, allowing the CPU to access the entire 4 GB of the MCH-M memory address space.

The MCH-M has a 12-deep In-Order Queue to support up to 12 outstanding pipelined address requests on the host bus. The MCH-M supports two outstanding defer cycles at a time; however, only one to any particular IO interface. Host initiated I/O cycles are positively decoded to AGP/PCI or MCH-M configuration space and subtractively decoded to the hub interface. Host initiated memory cycles are positively decoded to AGP/PCI or DRAM. AGP semantic memory accesses initiated from AGP/PCI to DRAM are not snooped on the host bus. Memory accesses initiated from AGP/PCI using PCI semantics and from the hub interface to DRAM will be snooped on the System bus. Memory accesses whose

addresses lie within the AGP aperture are translated using the AGP address translation table, regardless of the originating interface.

1.2.1. System Bus Error Checking

The Intel 845MP/845MZ Chipset MCH-M does not generate nor check parity for Data, Address/Request, and Response signals on the processor bus.

1.3. System Memory Interface

The Intel 845MP/845MZ Chipset memory controller directly supports one channel of PC1600 or PC2100 (845MZ PC1600 only) SO-DIMM DDR memory. The Intel 845MP/845MZ Chipset memory interface supports DDR devices with densities of 64-Mb, 128-Mb, 256-Mb, and 512-Mb technology. The maximum memory support is two, double-sided SO-DIMMs (four rows populated). The Intel 845MP/845MZ Chipset memory interface also supports variable page sizes of 2 KB, 4 KB, 8 KB, and 16 KB. Page size is individually selected for every row and a maximum of 16 pages may be opened simultaneously.

Table 1. DDR Memory Capacity

Technology	845MP/845MZ Maximum
64 Mb	128 MB/128 MB
128 Mb	256 MB/256 MB
256 Mb	512 MB/512 MB
512 Mb	1 GB/ 512 MB

The memory interface provides optional ECC error checking for DRAM data integrity. During DRAM writes, ECC is generated on a QWORD (64 bit) basis. Because the Intel 845MP/845MZ Chipset MCH-M stores only entire cache lines in its internal buffers, partial QWORD writes initially cause a read of the underlying data, and their write-back into memory is no different from that of a complete cache line. During DRAM reads and the read of the data that underlies partial writes, the MCH-M supports detection of single-bit and multiple-bit errors, and will correct single bit errors when correction is enabled.

Table 2. DDR Device Configurations

SO-DIMM Capacity	SO-DIMM Organization	Density	DDR Organization	# of Components	Package Type	# of Physical Banks	# of Banks in DDR	# Address Bits (row/col)
64 MB	8M x 64	64 Mbit	4M x 16	8	66 lead TSOP	2	4	12/8
64 MB	8M x 64	128 Mbit	8M x 16	4	66 lead TSOP	1	4	12/9
64 MB	8M x 72	128 Mbit	8M x 16	5	66 lead TSOP	1	4	12/9
128 MB	16M x 64	128 Mbit	8M x 16	8	66 lead TSOP	2	4	12/9
128 MB	16M x 64	256 Mbit	16M x 16	4	66 lead TSOP	1	4	13/9
128 MB	16M x 72	256 Mbit	16M x 16	5	66 lead TSOP	1	4	13/9
256 MB	32M x 64	256 Mbit	16M x 16	8	66 lead TSOP	2	4	13/9
256 MB	32M x 64	512 Mbit	32M x 16	4	66 lead TSOP	1	4	13/10
256 MB	32M x 72	512 Mbit	32M x 16	5	66 lead TSOP	1	4	13/10
512 MB	64M x 64	512 Mbit	32M x 16	8	66 lead TSOP	2	4	13/10
64 MB	8M x 64	64 Mbit	8M x 8	8	66 lead TSOP	1	4	12/9
128 MB	16M x 64	128 Mbit	16M x 8	8	66 lead TSOP	1	4	12/10
256 MB	32M x 64	256 Mbit	32M x 8	8	66 lead TSOP	1	4	13/10
512 MB	64M x 64	512 Mbit	64M x 8	8	66 lead TSOP	1	4	13/11

1.4. AGP Interface

A single AGP component or connector (not both) is supported by the Intel 845MP/845MZ Chipset MCH-M AGP interface. The AGP buffers operate only in 1.5-V mode. They are not 3.3-V safe.

The AGP interface supports 1x/2x/4x AGP signaling and 2x/4x Fast Writes. AGP semantic cycles to DRAM are not snooped on the host bus. PCI semantic cycles to DRAM are snooped on the host bus. The MCH-M supports PIPE# or SBA[7:0] AGP address mechanisms, but not both simultaneously. Either the PIPE# or the SBA[7:0] mechanism must be selected during system initialization. Both upstream and downstream addressing is limited to 32 bits for AGP and AGP/PCI transactions. The MCH-M contains a 32-deep AGP request queue. High priority accesses are supported. All accesses from the AGP/PCI interface that fall within the Graphics Aperture address range pass through an address translation mechanism with a fully associative 20 entry TLB. Accesses between AGP and hub interface are limited to memory writes originating from the hub interface destined for AGP. The AGP interface is clocked from a dedicated 66MHz clock (66IN). The AGP-to-host/core interface is asynchronous.

Consult the latest *AGP Busy and Stop Protocol Specification* for more information.

1.5. Hub Interface

The 8-bit hub interface connects the MCH-M to the ICH3-M. All communication between the MCH-M and the ICH3-M occurs over the hub interface. The hub interface runs at 66 MHz/266 MB/s. Aside from the obvious traffic types, the following communication also occur over hub interface:

- Interrupt related messages
- Power management events as messages
- SMI, SCI, and SERR error indication messages

It is assumed that the hub interface is always connected to an ICH3-M. This is a proprietary interconnect between the MCH-M and the ICH3-M.

1.6. MCH-M Clocking

The MCH-M has the following clock input pins:

- Differential BCLK[1:0] for the host interface
- 66-MHz clock input for the AGP and hub interface

Clock Synthesizer chip(s) are responsible for generating the system Host clocks, AGP and hub interface clocks, PCI clocks, and DRAM clocks. The Host target speed is 400 MT/s. The MCH-M does not require any relationship between the HCLKIN host clock and the 66-MHz clock generated for AGP and hub interface; they are totally asynchronous from each other. The AGP and hub interface runs at a constant 66-MHz base frequency. The hub interface runs at 4x, while AGP transfers may be 1x, 2x, or 4x.

The following tables indicate the frequency ratios between the various interfaces that the MCH-M supports.

Table 3. MCH-M Clock Ratio Table

Interface	Speed	CPU System Bus Frequency Ratio
System Memory	DDR 200 MHz	1:1 synchronous
AGP	66 MHz	Asynchronous
Hub interface	66 MHz	Asynchronous

1.7. System Interrupts

The Intel 845MP/845MZ Chipset MCH-M supports both 8259 and Intel Mobile Pentium 4 Processor-M interrupt delivery mechanisms. The serial APIC interrupt mechanism is not supported.

The 8259 support consists of flushing inbound hub interface write buffers when an Interrupt Acknowledge cycle is forwarded from the system bus to the hub interface.

The Intel 845MP/845MZ Chipset MCH-M supports the Mobile Intel Pentium 4 Processor-M interrupt delivery mechanism. PCI MSI interrupts are generated as Memory Writes. The MCH-M decodes upstream Memory Writes to the range 0FEE0_0000h - 0FEEF_FFFFh from AGP and the hub interface as message based interrupts. The MCH-M forwards the Memory Writes, along with the associated write data, to the system bus as an Interrupt Message transaction. Note that since this address does not decode as part of main memory, the write cycle and the write data does not get forwarded to DRAM via the write buffer. The Intel 845MP/845MZ Chipset MCH-M provides the response and TRDY# for all Interrupt Message cycles including the ones originating from the MCH-M. The Intel 845MP/845MZ Chipset MCH-M supports interrupt re-direction for inter-processor interrupts (IPIs) as well as upstream interrupt memory writes.

For message based interrupts, system write buffer coherency is maintained by relying on strict ordering of Memory Writes. The Intel 845MP/845MZ Chipset MCH-M ensures that all Memory Writes received from a given interface prior to an interrupt message Memory Write are delivered to the system bus for snooping in the same order that they occur on the given interface.

2. Signal Description

This section provides a detailed description of Intel 845MP/845MZ Chipset MCH-M signals. The signals are arranged in functional groups according to their associated interface. The states of all of the signals during reset are provided in the System Reset section.

The “#” symbol at the end of a signal name indicates that the active, or asserted state occurs when the signal is at a low voltage level. When “#” is not present after the signal name, the signal is asserted when at the high voltage level.

The following notations are used to describe the signal type:

I	Input pin
O	Output pin
I/O	Bi-directional Input/Output pin
s/t/s	Sustained Tristate. This pin is driven to its inactive state prior to tri-stating.
as/t/s	Active Sustained Tristate. This applies to some of the hub interface signals. This pin is weakly driven to its last driven value.

The signal description also includes the type of buffer used for the particular signal:

AGTL+	Open Drain AGTL+ interface signal. Refer to the AGTL+ I/O Specification for complete details. The Intel® 845MP/845MZ Chipset MCH-M integrates AGTL+ termination resistors.
AGP	AGP interface signals. These signals are compatible with AGP 2.0 1.5v Signaling Environment DC and AC Specifications. The buffers are not 3.3v tolerant.
CMOS	CMOS buffers.
Ref	Voltage reference signal.

Note: System address and data bus signals are logically inverted signals. The actual values are inverted of what appears on the system bus. This must be taken into account and the addresses and data bus signals must be inverted inside the Intel 845MP/845MZ Chipset MCH-M. All processor control signals follow normal convention. A “0” indicates an active level (low voltage) if the signal is followed by “#” symbol, and a “1” indicates an active level (high voltage) if the signal has no “#” suffix.

2.1. Host Interface Signals

Table 4. Host Interface Signal Descriptions

Signal Name	Type	Description										
ADS#	I/O AGTL+	Address Strobe: The system bus owner asserts ADS# to indicate the first of two cycles of a request phase.										
BNR#	I/O AGTL+	Block Next Request: Used to block the current request bus owner from issuing a new request. This signal is used to dynamically control the system bus pipeline depth.										
BPRI#	O AGTL+	Bus Priority Request: The MCH-M is the only Priority Agent on the system bus. It asserts this signal to obtain the ownership of the address bus. This signal has priority over symmetric bus requests and will cause the current symmetric owner to stop issuing new transactions unless the HLOCK# signal was asserted.										
BR0#	I/O AGTL+	Bus Request 0#: The MCH-M pulls the processor bus' BR0# signal low during CPURST# . The signal is sampled by the processor on the active-to-inactive transition of CPURST# . The minimum setup time for this signal is 4 HCLKs. The minimum hold time is 2 clocks and the maximum hold time is 20 HCLKs. BR0# should be tristated after the hold time requirement has been satisfied.										
CPURST#	O AGTL+	CPU Reset: The CPURST# pin is an output from the MCH-M. The MCH-M asserts CPURST# while RSTIN# (PCIRST# from ICH3-M) is asserted and for approximately 1 ms after RSTIN# is deasserted. The CPURST# allows the processor's to begin execution in a known state.										
DBSY#	I/O AGTL+	Data Bus Busy: Used by the data bus owner to hold the data bus for transfers requiring more than one cycle.										
DEFER#	O AGTL+	Defer Response: Signals that the MCH-M will terminate the transaction currently being snooped with either a deferred response or with a retry response.										
DBI[3:0]#	I/O AGTL+ 4x	<p>Dynamic Bus Inversion: Driven along with the HD[63:0]# signals. Indicates if the associated signals are inverted or not. DBI[3:0]# are asserted such that the number of data bits driven electrically low (low voltage) within the corresponding 16-bit group never exceeds 8.</p> <table border="0"> <tr> <td><u>DBI[x]#</u></td> <td><u>Data Bits</u></td> </tr> <tr> <td>DBI3#</td> <td>HD[63:48]#</td> </tr> <tr> <td>DBI2#</td> <td>HD[47:32]#</td> </tr> <tr> <td>DBI1#</td> <td>HD[31:16]#</td> </tr> <tr> <td>DBI0#</td> <td>HD[15:0]#</td> </tr> </table>	<u>DBI[x]#</u>	<u>Data Bits</u>	DBI3#	HD[63:48]#	DBI2#	HD[47:32]#	DBI1#	HD[31:16]#	DBI0#	HD[15:0]#
<u>DBI[x]#</u>	<u>Data Bits</u>											
DBI3#	HD[63:48]#											
DBI2#	HD[47:32]#											
DBI1#	HD[31:16]#											
DBI0#	HD[15:0]#											
DRDY#	I/O AGTL+	Data Ready: Asserted for each cycle that data is transferred.										
HA[31:3]#	I/O AGTL+ 2x	Host Address Bus: HA[31:3]# connect to the system address bus. During processor cycles the HA[31:3]# are inputs. The MCH-M drives HA[31:3]# during snoop cycles on behalf of hub interface and AGP/Secondary PCI initiators. HA[31:3]# are transferred at 2x rate. Note that the address is inverted on the system bus.										
HADSTB[1:0]#	I/O AGTL+ 2x	<p>Host Address Strobe: The source synchronous strobes used to transfer HA[31:3]# and HREQ[4:0]# at the 2x transfer rate.</p> <table border="0"> <tr> <td><u>Strobe</u></td> <td><u>Address Bits</u></td> </tr> <tr> <td>HADSTB0#</td> <td>HA[16:3]#, HREQ[4:0]#</td> </tr> <tr> <td>HADSTB1#</td> <td>HA[31:17]#</td> </tr> </table>	<u>Strobe</u>	<u>Address Bits</u>	HADSTB0#	HA[16:3]#, HREQ[4:0]#	HADSTB1#	HA[31:17]#				
<u>Strobe</u>	<u>Address Bits</u>											
HADSTB0#	HA[16:3]#, HREQ[4:0]#											
HADSTB1#	HA[31:17]#											

Signal Name	Type	Description																		
HD[63:0]#	I/O AGTL+ 4x	Host Data: These signals are connected to the system data bus. HD[63:0]# are transferred at 4x rate. Note that the data signals are inverted on the system bus.																		
HDSTBP[3:0]# HDSTBN[3:0]#	I/O AGTL+ 4x	Differential Host Data Strobes: The differential source synchronous strobes used to transfer HD[63:0]# and DBI[3:0]# at the 4x transfer rate. <table border="0"> <thead> <tr> <th><u>Strobe</u></th> <th><u>Data Bits</u></th> </tr> </thead> <tbody> <tr> <td>HDSTBP3#, HDSTBN3#</td> <td>HD[63:48]#, DBI3#</td> </tr> <tr> <td>HDSTBP2#, HDSTBN2#</td> <td>HD[47:32]#, DBI2#</td> </tr> <tr> <td>HDSTBP1#, HDSTBN1#</td> <td>HD[31:16]#, DBI1#</td> </tr> <tr> <td>HDSTBP0#, HDSTBN0#</td> <td>HD[15:0]#, DBI0#</td> </tr> </tbody> </table>	<u>Strobe</u>	<u>Data Bits</u>	HDSTBP3#, HDSTBN3#	HD[63:48]#, DBI3#	HDSTBP2#, HDSTBN2#	HD[47:32]#, DBI2#	HDSTBP1#, HDSTBN1#	HD[31:16]#, DBI1#	HDSTBP0#, HDSTBN0#	HD[15:0]#, DBI0#								
<u>Strobe</u>	<u>Data Bits</u>																			
HDSTBP3#, HDSTBN3#	HD[63:48]#, DBI3#																			
HDSTBP2#, HDSTBN2#	HD[47:32]#, DBI2#																			
HDSTBP1#, HDSTBN1#	HD[31:16]#, DBI1#																			
HDSTBP0#, HDSTBN0#	HD[15:0]#, DBI0#																			
HIT#	I/O AGTL+	Hit: Indicates that a caching agent holds an unmodified version of the requested line. Also, driven in conjunction with HITM# by the target to extend the snoop window.																		
HITM#	I/O AGTL+	Hit Modified: Indicates that a caching agent holds a modified version of the requested line and that this agent assumes responsibility for providing the line. Also, driven in conjunction with HIT# to extend the snoop window.																		
HLOCK#	I AGTL+	Host Lock: All system bus cycles sampled with the assertion of HLOCK# and ADS# , until the negation of HLOCK# must be atomic, i.e. no hub interface or AGP snoopable access to DRAM are allowed when HLOCK# is asserted by the processor.																		
HREQ[4:0]#	I/O AGTL+ 2x	Host Request Command: Defines the attributes of the request. In Enhanced Mode HREQ[4:0]# are transferred at 2x rate. Asserted by the requesting agent during both halves of Request Phase. In the first half the signals define the transaction type to a level of detail that is sufficient to begin a snoop request. In the second half the signals carry additional information to define the complete transaction type. The transactions supported by the MCH-M Host Bridge are defined in the Host Interface section of this document.																		
HTRDY#	O AGTL+	Host Target Ready: Indicates that the target of the processor transaction is able to enter the data transfer phase.																		
RS[2:0]#	O AGTL+	Response Status: Indicates type of response according to the following the table: <table border="0"> <thead> <tr> <th><u>RS[2:0]</u></th> <th><u>Response type</u></th> </tr> </thead> <tbody> <tr> <td>000</td> <td>Idle state</td> </tr> <tr> <td>001</td> <td>Retry response</td> </tr> <tr> <td>010</td> <td>Deferred response</td> </tr> <tr> <td>011</td> <td>Reserved (not driven by MCH-M)</td> </tr> <tr> <td>100</td> <td>Hard Failure (not driven by MCH-M)</td> </tr> <tr> <td>101</td> <td>No data response</td> </tr> <tr> <td>110</td> <td>Implicit Write back</td> </tr> <tr> <td>111</td> <td>Normal data response</td> </tr> </tbody> </table>	<u>RS[2:0]</u>	<u>Response type</u>	000	Idle state	001	Retry response	010	Deferred response	011	Reserved (not driven by MCH-M)	100	Hard Failure (not driven by MCH-M)	101	No data response	110	Implicit Write back	111	Normal data response
<u>RS[2:0]</u>	<u>Response type</u>																			
000	Idle state																			
001	Retry response																			
010	Deferred response																			
011	Reserved (not driven by MCH-M)																			
100	Hard Failure (not driven by MCH-M)																			
101	No data response																			
110	Implicit Write back																			
111	Normal data response																			

2.2. DDR Interface

Table 5. DDR Interface Signal Descriptions

Signal Name	Type	Description
SCS#[3:0]	O CMOS	Chip Select: These pins select the particular DDR components during the active state. Note: There is one SCS# per DDR-SDRAM Physical SO-DIMM device row. These signals can be toggled on every rising System Memory Clock edge.
SMA[12:0]	O CMOS	Multiplexed Memory Address: These signals are used to provide the multiplexed row and column address to DDR.
SBS[1:0]	O CMOS	Memory Bank Address: These signals define the banks that are selected within each DDR row. The SMA and SBS signals combine to address every possible location within a DDR device.
SRAS#	O CMOS	DDR Row Address Strobe: SRAS# may be heavily loaded and requires 2 DDR clock cycles for setup time to the DDRs: Used with SCAS# and SWE# (along with SCS#) to define the DRAM commands.
SCAS#	O CMOS	DDR Column Address Strobe: SCAS# may be heavily loaded and requires 2 DDR clock cycles for setup time to the DDRs. Used with SRAS# and SWE# (along with SCS#) to define the DRAM commands.
SWE#	I/O CMOS	Write Enable: Used with SCAS# and SRAS# (along with SCS#) to define the DRAM commands. SWE# is asserted during writes to DDR. SWE# may be heavily loaded and requires 2 DDR clock cycles for setup time to the DDRs.
SDQ[63:0]	I/O CMOS 2X	Data Lines: These signals are used to interface to the DDR data bus.
SCB[7:0]	I/O CMOS 2X	Data Lines: These signals are used to interface to the SDRAM ECC signals (to be used if SO-DIMMs support ECC).
SDQS[8:0]	I/O CMOS	Data Strobes: There is an associated data strobe (DQS) for each data strobe (DQ) and check bit (CB) group. SDQS8 -> SCB[7:0] SDQS7 -> SDQ[63:56] SDQS6 -> SDQ[55:48] SDQS5 -> SDQ[47:40] SDQS4 -> SDQ[39:32] SDQS3 -> SDQ[31:24] SDQS2 -> SDQ[23:16] SDQS1 -> SDQ[15:8] SDQS0 -> SDQ[7:0]
SCKE[3:0]	O CMOS	Clock Enable: These pins are used to signal a self-refresh or power down command to a DDR array when entering system suspend. SCKE is also used to dynamically power down inactive DDR rows. There is one SCKE per DDR row. These signals can be toggled on every rising SCLK edge.
RCVENOUT#	O CMOS	Clock Output: Used to emulate source-synch clocking for reads. Connects to RCVENIN#.
RCVENIN#	I CMOS	Clock Input: Used to emulate source-synch clocking for reads. Connects to RCVENOUT#.

2.3. Hub Interface Signals

Table 6. Hub Interface Signal Descriptions

Signal Name	Type	Description
HI_[10:0]	I/O CMOS	Hub Interface Signals: Signals used for the hub interface.
HI_STB	I/O CMOS	Hub Interface Strobe: One of two differential strobe signals used to transmit or receive packet data over hub interface.
HI_STB#	I/O CMOS	Hub Interface Strobe Complement: One of two differential strobe signals used to transmit or receive packet data over hub interface.

2.4. AGP Interface Signals

2.4.1. AGP Addressing Signals

Table 7. AGP Addressing Signal Descriptions

Signal Name	Type	Description
PIPE#	I AGP	<p>Pipelined Read: This signal is asserted by the AGP master to indicate a full width address is to be enqueued on by the target using the AD bus. One address is placed in the AGP request queue on each rising clock edge while PIPE# is asserted. When PIPE# is deasserted no new requests are queued across the AD bus.</p> <p>During SBA Operation: This signal is not used if SBA (Side Band Addressing) is selected.</p> <p>During FRAME# Operation: This signal is not used during AGP FRAME# operation.</p> <p>PIPE# is a sustained tri-state signal from the AGP masters (graphics controller) and is an MCH-M input.</p>
SBA[7:0]	I AGP	<p>Side-band Address: These signals are used by the AGP master (graphics controller) to place addresses into the AGP request queue. The SBA bus and AD bus operate independently. That is, transaction can proceed on the SBA bus and the AD bus simultaneously.</p> <p>During PIPE# Operation: These signals are not used during PIPE# operation.</p> <p>During FRAME# Operation: These signal are not used during AGP FRAME# operation.</p> <p>Note: When sideband addressing is disabled, these signals are isolated (no external/internal pull-ups are required).</p>

NOTE: The above table contains two mechanisms, SBA and PIPE#, to queue requests by the AGP master. Note that the master can only use one mechanism. The master may not switch methods without a full reset of the system. When PIPE# is used to queue addresses, the master is not allowed to queue addresses using the SBA bus. For example, during configuration time, if the master indicates that it can use either mechanism, the configuration software will select which mechanism the master will use. Once this choice has been made, the master must continue to use the mechanism selected until the master is reset (and reprogrammed) to use the other mode. This change of modes is not a dynamic mechanism, but rather a static decision when the device is first being configured after reset.

2.4.2. AGP Flow Control Signals

Table 8. AGP Flow Control Signal Descriptions

Signal Name	Type	Description
RBF#	I AGP	<p>Read Buffer Full: Indicates if the master is ready to accept previously requested low priority read data. When RBF# is asserted, the MCH-M is not allowed to initiate the return of low priority read data. That is, the MCH-M can only finish returning the data for the request currently being serviced. RBF# is only sampled at the beginning of a cycle.</p> <p>If the AGP master is always ready to accept return read data then it is not required to implement this signal.</p> <p>During FRAME# Operation: This signal is not used during AGP FRAME# operation.</p>
WBF#	I AGP	<p>Write-Buffer Full: indicates if the master is ready to accept Fast Write data from the MCH-M. When WBF# is asserted the MCH-M is not allowed to drive Fast Write data to the AGP master. WBF# is only sampled at the beginning of a cycle.</p> <p>If the AGP master is always ready to accept fast write data then it is not required to implement this signal.</p> <p>During FRAME# Operation: This signal is not used during AGP FRAME# operation.</p>

2.4.3. AGP Status Signals

Table 9. AGP Status Signal Descriptions

Signal Name	Type	Description
ST[2:0]	O AGP	<p>Status: Provides information from the arbiter to an AGP Master on what it may do. ST[2:0] only have meaning to the master when its GNT# is asserted. When GNT# is deasserted these signals have no meaning and must be ignored. Refer to the AGP Interface Specification revision 2.0 for further explanation of the ST[2:0] values and their meanings.</p> <p>During FRAME# Operation: These signals are not used during FRAME# based operation; except that a '111' indicates that the master may begin a FRAME# transaction.</p>

2.4.4. AGP Strobes

Table 10. AGP Strobe Descriptions

Signal Name	Type	Description
AD_STB0	I/O (s/t/s) AGP	Address/Data Bus Strobe-0: provides timing for 2x and 4x data on AD[15:0] and C/BE[1:0]# signals. The agent that is providing the data will drive this signal.
AD_STB0#	I/O (s/t/s) AGP	Address/Data Bus Strobe-0 Complement: With AD STB0, forms a differential strobe pair that provides timing information for the AD[15:0] and C/BE[1:0]# signals. The agent that is providing the data will drive this signal.
AD_STB1	I/O (s/t/s) AGP	Address/Data Bus Strobe-1: Provides timing for 2x and 4x data on AD[31:16] and C/BE[3:2]# signals. The agent that is providing the data will drive this signal.
AD_STB1#	I/O (s/t/s) AGP	Address/Data Bus Strobe-1 Complement: With AD STB1, forms a differential strobe pair that provides timing information for the AD[15:0] and C/BE[1:0]# signals in 4X mode. The agent that is providing the data will drive this signal.
SB_STB	I AGP	Sideband Strobe: Provides timing for 2x and 4x data on the SBA[7:0] bus. The AGP master drives it after the system has been configured for 2x or 4x sideband address mode.
SB_STB#	I AGP	Sideband Strobe Complement: The differential complement to the SB_STB signal. It is used to provide timing 4x mode.

2.4.5. AGP/PCI Signals-Semantics

For transactions on the AGP interface carried using AGP FRAME# protocol these signals operate similar to their semantics in the PCI 2.1 specification the exact role of all AGP FRAME# signals are defined below.

Table 11. AGP/PCI Signal Semantics Descriptions

Signal Name	Type	Description
G_FRAME#	I/O s/t/s AGP	<p>G_FRAME#: Frame</p> <p>During PIPE# and SBA Operation: Not used by AGP SBA and PIPE# operations.</p> <p>During Fast Write Operation: Used to frame transactions as an output during Fast Writes.</p> <p>During FRAME# Operation: G_FRAME# is an output when the MCH-M acts as an initiator on the AGP Interface. G_FRAME# is asserted by the MCH-M to indicate the beginning and duration of an access. G_FRAME# is an input when the MCH-M acts as a FRAME#-based AGP target. As a FRAME#-based AGP target, the MCH-M latches the C/BE[3:0]# and the AD[31:0] signals on the first clock edge on which MCH-M samples FRAME# active.</p>
G_IRDY#	I/O s/t/s AGP	<p>G_IRDY#: Initiator Ready</p> <p>During PIPE# and SBA Operation: Not used while enqueueing requests via AGP SBA and PIPE#, but used during the data phase of PIPE# and SBA transactions.</p> <p>During FRAME# Operation: G_IRDY# is an output when MCH-M acts as a FRAME#-based AGP initiator and an input when the MCH-M acts as a FRAME#-based AGP target. The assertion of G_IRDY# indicates the current FRAME#-based AGP bus initiator's ability to complete the current data phase of the transaction.</p> <p>During Fast Write Operation: In Fast Write mode, G_IRDY# indicates that the AGP-compliant master is ready to provide all write data for the current transaction. Once G_IRDY# is asserted for a write operation, the master is not allowed to insert wait states. The master is never allowed to insert a wait state during the initial data transfer (32 bytes) of a write transaction. However, it may insert wait states after each 32-byte block is transferred.</p>
G_TRDY#	I/O s/t/s AGP	<p>G_TRDY#: Target Ready</p> <p>During PIPE# and SBA Operation: Not used while enqueueing requests via AGP SBA and PIPE#, but used during the data phase of PIPE# and SBA transactions.</p> <p>During FRAME# Operation: G_TRDY# is an input when the MCH-M acts as an AGP initiator and is an output when the MCH-M acts as a FRAME#-based AGP target. The assertion of G_TRDY# indicates the target's ability to complete the current data phase of the transaction.</p> <p>During Fast Write Operation: In Fast Write mode, G_TRDY# indicates the AGP-compliant target is ready to receive write data for the entire transaction (when the transfer size is less than or equal to 32 bytes) or is ready to transfer the initial or subsequent block (32 bytes) of data when the transfer size is greater than 32 bytes. The target is allowed to insert wait states after each block (32 bytes) is transferred on write transactions.</p>

Signal Name	Type	Description
G_STOP#	I/O s/t/s AGP	<p>G_STOP#: Stop</p> <p>During PIPE# and SBA Operation: This signal is not used during PIPE# or SBA operation.</p> <p>During FRAME# Operation: G_STOP# is an input when the MCH-M acts as a FRAME#-based AGP initiator and is an output when the MCH-M acts as a FRAME#-based AGP target. G_STOP# is used for disconnect, retry, and abort sequences on the AGP interface</p>
G_DEVSEL#	I/O s/t/s AGP	<p>G_DEVSEL#: Device Select</p> <p>During PIPE# and SBA Operation: This signal is not used during PIPE# or SBA operation.</p> <p>During FRAME# Operation: G_DEVSEL#, when asserted, indicates that a FRAME#-based AGP target device has decoded its address as the target of the current access. The MCH-M asserts G_DEVSEL# based on the SDRAM address range being accessed by a PCI initiator. As an input, G_DEVSEL# indicates whether the AGP master has recognized a PCI cycle to it.</p>
G_REQ#	I AGP	<p>G_REQ#: Request</p> <p>During SBA Operation: This signal is not used during SBA operation.</p> <p>During PIPE# and FRAME# Operation: G_REQ#, when asserted, indicates that the AGP master is requesting use of the AGP interface to run a FRAME#- or PIPE#-based operation.</p>
G_GNT#	O AGP	<p>G_GNT#: Grant</p> <p>During SBA, PIPE# and FRAME# Operation: G_GNT#, along with the information on the ST[2:0] signals (status bus), indicates how the AGP interface will be used next. Refer to the <i>AGP Interface Specification, Revision 2.0</i> for further explanation of the ST[2:0] values and their meanings.</p>
G_AD[31:0]	I/O AGP	<p>G_AD[31:0]: Address/Data Bus</p> <p>During PIPE# and FRAME# Operation: The G_AD[31:0] signals are used to transfer both address and data information on the AGP interface.</p> <p>During SBA Operation: The G_AD[31:0] signals are used to transfer data on the AGP interface.</p>
G_CBE[3:0]#	I/O AGP	<p>Command/Byte Enable</p> <p>During FRAME# Operation: During the address phase of a transaction, the G_CBE[3:0]# signals define the bus command. During the data phase, the G_CBE[3:0]# signals are used as byte enables. The byte enables determine which byte lanes carry meaningful data. The commands issued on the G_CBE# signals during FRAME#-based AGP transactions are the same G_CBE# command described in the PCI 2.2 specification.</p> <p>During PIPE# Operation: When an address is enqueued using PIPE#, the C/BE# signals carry command information. Refer to the <i>AGP 2.0 Interface Specification, Revision 2.0</i> for the definition of these commands. The command encoding used during PIPE#-based AGP is <i>different</i> than the command encoding used during FRAME#-based AGP cycles (or standard PCI cycles on a PCI bus).</p> <p>During SBA Operation: These signals are not used during SBA operation.</p>

Signal Name	Type	Description
G_PAR	I/O AGP	<p>Parity</p> <p>During FRAME# Operation: G_PAR is driven by the MCH-M when it acts as a FRAME#-based AGP initiator during address and data phases for a write cycle, and during the address phase for a read cycle. G_PAR is driven by the MCH-M when it acts as a FRAME#-based AGP target during each data phase of a FRAME#-based AGP memory read cycle. Even parity is generated across G_AD[31:0] and G_CBE[3:0]#.</p> <p>During SBA and PIPE# Operation: This signal is not used during SBA and PIPE# operation.</p>

NOTE: PCIRST# from the ICH3-M is connected to RSTIN# and is used to reset AGP interface logic within the MCH-M. The AGP agent will also use PCIRST# provided by the ICH3-M as an input to reset its internal logic.

2.5. Clocks, Reset, and Miscellaneous

Table 12. Clocks, Reset, and Miscellaneous Descriptions

Signal Name	Type	Description
BCLK / BCLK#	I CMOS	Differential Host Clock In: These pins receive a differential host clock from the external clock synthesizer. This clock is used by all of the MCH-M logic that is in the Host clock domain.
66IN	I CMOS	66-MHz Clock In: This pin receives a 66-MHz clock from the clock synthesizer. This clock is used by AGP/PCI and hub interface clock domains. Note: That this clock input is 3.3-V tolerant.
SCK[5:0]	O CMOS	SDRAM Differential Clock (DDR): These signals deliver a source synchronous clock to the <u>SO-DIMMs</u> . There are three per <u>SO-DIMM</u> .
SCK#[5:0]	O CMOS	SDRAM Inverted Differential Clock (DDR): These signals are the complement to the SCK[5:0] signals. There are three per <u>SO-DIMM</u> .
RSTIN#	I CMOS	Reset In: When asserted this signal will asynchronously reset the MCH-M logic. This signal is connected to the PCIRST# output of the ICH3-M. All AGP/PCI output and bi-directional signals will also tri-state compliant to PCI Rev 2.0 and 2.1 specifications. Note: That this input needs to be 3.3-V tolerant.
TESTIN#	I CMOS	Test Input: This pin is used for manufacturing and board level test purposes. Note: This signal has an internal pullup resistor.

2.6. Voltage References, PLL Power

Table 13. Voltage Reference Descriptions

Signal Name	Type	Description
HVREF	Ref	Host Reference Voltage. Reference voltage input for the Data, Address, and Common clock signals of the Host AGTL+ interface
SDREF	Ref	DDR Reference Voltage: Reference voltage input for DQ, DQS, & RCVENIN#.
HI_REF	Ref	Hub Interface Reference: Reference voltage input for the hub interface.
AGPREF	Ref	AGP Reference: Reference voltage input for the AGP interface.
HLCOMP	I/O CMOS	Compensation for hub interface: This signal is used to calibrate the hub interface I/O buffers.
GRCOMP	I/O CMOS	Compensation for AGP: This signal is used to calibrate AGP buffers.
HRCOMP[1:0]	I/O CMOS	Compensation for Host: This signal is used to calibrate the Host AGTL+ I/O buffers.
HSWNG[1:0]	I CMOS	Host Reference Voltage: Reference voltage input for the compensation logic.
SMRCOMP	I/O CMOS	System Memory RCOMP
VCC1_5		The 1.5 V Power input pins
VCC1_8		The 1.8 V Power input pins
VCCSM		The SDRAM Power input pins. 2.5 V for DDR.
VCCA[1:0]		PLL power input pins.
VTT		The AGTL+ bus termination voltage inputs
VSS		GROUND
VSSA[1:0]		PLL Ground

2.7. Pin State Table

This section describes the expected states of the MCH-M I/O buffers. These tables only refer to the contributions on the interface from the MCH-M and do NOT reflect any external influence (such as external pullup/pulldown resistors or external drivers).

Legend :

Term H/L: Normal termination devices are turned on high/low

Pwrnd: Power down

H/L: Strong Drive low

Tri/High-Z: High Impedance

IN: Input buffer Enabled

PU, PD/PL: Weak internal pull-up, Weak internal pull down

(Strap): Strap input sampled during assertion or on the deassertion edge of RSTIN#

Table 14. Host Signals

	Buffer Type/I/O	Signal Type	State During RSTIN# Assertion	State After RSTIN# Deassertion	C3	S1M	S3	S4-S5	G3
HA[31:3]#	GTL+	I/O	Term H	Term H	Term H	Term H	Pwrdn	Pwrdn	Pwrdn
HD[63:0]#	GTL+	I/O	Term H	Term H	Term H	Term H	Pwrdn	Pwrdn	Pwrdn
ADS#	GTL+	I/O	Term H	Term H	Term H	Term H	Pwrdn	Pwrdn	Pwrdn
BNR#	GTL+	I/O	Term H	Term H	Term H	Term H	Pwrdn	Pwrdn	Pwrdn
BPRI#	GTL+	O	Term H	Term H	Term H	Term H	Pwrdn	Pwrdn	Pwrdn
DBSY#	GTL+	I/O	Term H	Term H	Term H	Term H	Pwrdn	Pwrdn	Pwrdn
DEFER#	GTL+	O	Term H	Term H	Term H	Term H	Pwrdn	Pwrdn	Pwrdn
DRDY#	GTL+	I/O	Term H	Term H	Term H	Term H	Pwrdn	Pwrdn	Pwrdn
HIT#	GTL+	I/O	Term H	Term H	Term H	Term H	Pwrdn	Pwrdn	Pwrdn
HITM#	GTL+	I/O	Term H	Term H	Term H	Term H	Pwrdn	Pwrdn	Pwrdn
HLOCK#	GTL+	I	Term H	Term H	N/a	N/a	N/a	N/a	N/a
HREQ[4:0]#	GTL+	I/O	Term H	Term H	Term H	Term H	Pwrdn	Pwrdn	Pwrdn
HTRDY#	GTL+	I/O	Term H	Term H	Term H	Term H	Pwrdn	Pwrdn	Pwrdn
RS[2:0]#	GTL+	O	Term H	Term H	Term H	Term H	Pwrdn	Pwrdn	Pwrdn
CPURST#	GTL+	O	Drive L	Term H after 1 ms	Term H	Term H	Pwrdn	Pwrdn	Pwrdn

Table 15. DDR Signals

	Buffer Type/IO	Signal Type	State During RSTIN# Assertion	State After RSTIN# Deassertion	C3	S1M	S3	S4-S5	G3
SCK#[5:0]	SM common	O	TRI	DRIVE	Don't care	Don't care	Don't care	Pwrdn	Pwrdn
SCK[4:0]	SM common	O	TRI	DRIVE	Don't care	Don't care	Don't care	Pwrdn	Pwrdn
SCK[5]	SM common	O	TRI	DRIVE	L	L	L	Pwrdn	Pwrdn
SCKE[3:0]	SM common	O	DRIVE L	DRIVE L	L	L	L	Pwrdn	Pwrdn
SDQ[63:59]	SM common	I/O	PU	PU	Hi-Z	Hi-Z	PU or PD *	Pwrdn	Pwrdn
SDQ[58]	SM common	I/O	PU	PU	L	L	L	Pwrdn	Pwrdn
SDQ[57:56]	SM common	I/O	PU	PU	Hi-Z	Hi-Z	PU or PD *	Pwrdn	Pwrdn
SDQ[55]	SM common	I/O	PU	PU	L	L	L	Pwrdn	Pwrdn
SDQ[54:0]	SM common	I/O	PU	PU	Hi-Z	Hi-Z	PU or PD *	Pwrdn	Pwrdn
SCB[7:0]	SM common	I/O	PU	PU	Hi-Z	Hi-Z	PU or PD *	Pwrdn	Pwrdn
SDQS[8:0]	SM common	I/O	TRI	TRI	Hi-Z	Hi-Z	PU or PD *	Pwrdn	Pwrdn
RCVENIN#	SM common	I	IN	IN	Hi	Hi	Don't care	Pwrdn	Pwrdn
RCVENOUT#	SM common	O	TRI	Drive H	Hi	Hi	PU or PD *	Pwrdn	Pwrdn
SBS[1:0]	SM common	O	TRI	DRIVE	Hi-Z	Hi-Z	PU or PD *	Pwrdn	Pwrdn
SRAS#	SM common	O	TRI	DRIVE	Hi-Z	Hi-Z	PU or PD *	Pwrdn	Pwrdn
SWE#	SM common	O	TRI	DRIVE	L	L	L	Pwrdn	Pwrdn
SCAS#	SM common	O	TRI	DRIVE	Hi-Z	Hi-Z	PU or PD *	Pwrdn	Pwrdn
SMA[12:0]	SM common	O	TRI	DRIVE	Hi-Z	Hi-Z	PU or PD *	Pwrdn	Pwrdn
SCS#[3:0]	SM common	O	TRI	Drive H	Hi-Z	Hi-Z	PU or PD *	Pwrdn	Pwrdn

* There is an indeterminate number of non-CKE DDR pins that will be pull-down in S3.

Table 16. AGP Signals

	Buffer Type IO	Signal Type	State During RSTIN# Assertion	State After RSTIN# Deassertion	Pull Up/Pull Down	C3	S1M	S3	S4-S5	G3
PIPE#	CMOS	Input	PU	PU	8.2K Int Pullup	H	H	Pwrdn	Pwrdn	Pwrdn
SBA[7:0]	CMOS	Input	PU (Strap)	PU	8.2K Int Pullup	H	H	Pwrdn	Pwrdn	Pwrdn
RBF#	CMOS	Input	PU (Strap)	PU	8.2K Int Pullup	H	H	Pwrdn	Pwrdn	Pwrdn
WBF#	CMOS	Input	PU (Strap)	PU	8.2K Int Pullup	H	H	Pwrdn	Pwrdn	Pwrdn
ST[2:0]	CMOS	Output	PU (Strap)	DRIVE L		Hi-Z	Hi-Z	Pwrdn	Pwrdn	Pwrdn
AD_STB0	CMOS	I/O	PU	PU	8.2K Int Pullup	PU	PU	Pwrdn	Pwrdn	Pwrdn
AD_STB0 #	CMOS	I/O	PD	PD	8.2K Int Pulldwn	PL	PL	Pwrdn	Pwrdn	Pwrdn
AD_STB1	CMOS	I/O	PU	PU	8.2K Int Pullup	PU	PU	Pwrdn	Pwrdn	Pwrdn
AD_STB1 #	CMOS	I/O	PD	PD	8.2K Int Pulldwn	PD	PD	Pwrdn	Pwrdn	Pwrdn
SB_STB	CMOS	I	PU	PU	8.2K Int Pullup	PU	PU	Pwrdn	Pwrdn	Pwrdn
SB_STB#	CMOS	I	PD	PD	8.2K Int Pulldwn	PD	PD	Pwrdn	Pwrdn	Pwrdn
G_FRAM E#	CMOS	I/O	PU	PU	8.2K Int Pullup	PU	PU	Pwrdn	Pwrdn	Pwrdn
G_IRDY#	CMOS	I/O	PU	PU	8.2K Int Pullup	PU	PU	Pwrdn	Pwrdn	Pwrdn
G_TRDY #	CMOS	I/O	PU	PU	8.2K Int Pullup	PU	PU	Pwrdn	Pwrdn	Pwrdn
G_STOP #	CMOS	I/O	PU	PU	8.2K Int Pullup	PU	PU	Pwrdn	Pwrdn	Pwrdn
G_DEVS EL#	CMOS	I/O	PU	PU	8.2K Int Pullup	PU	PU	Pwrdn	Pwrdn	Pwrdn
G_REQ#	CMOS	Input	PU	PU	8.2K Int Pullup	PU	PU	Pwrdn	Pwrdn	Pwrdn
G_GNT#	CMOS	Output	PU (Strap)	DRIVE H	8.2K Int Pullup	PU	PU	Pwrdn	Pwrdn	Pwrdn
G_AD[31:0]	CMOS	I/O	TRI	TRI		Hi-Z	Hi-Z	Pwrdn	Pwrdn	Pwrdn
G_C/BE[3:0]#	CMOS	I/O	TRI	TRI		Hi-Z	Hi-Z	Pwrdn	Pwrdn	Pwrdn
G_PAR	CMOS	I/O	TRI	TRI		Hi-Z	Hi-Z	Pwrdn	Pwrdn	Pwrdn

Table 17. Clock/Miscellaneous Signals

	Buffer Type/I/O	Signal Type	State During RSTIN# Assertion	State After RSTIN# Deassertion	C3	S1M	S3	S4-S5	G3
BCLK/#	CMOS	I	IN	IN	Running	Stopped(L)	Pwrdsn	Pwrdsn	Pwrdsn
66IN	CMOS	I	N/A	N/A	Running	Stopped(L)	Pwrdsn	Pwrdsn	Pwrdsn
RSTIN#	CMOS	I	IN	IN	H	H	L	L	Pwrdsn
GRCOMP	CMOS	I/O	Tri	N/A	Hi-Z	Hi-Z	Pwrdsn	Pwrdsn	Pwrdsn
HLRCOMP	CMOS	I/O	Tri	N/A	Hi-Z	Hi-Z	Pwrdsn	Pwrdsn	Pwrdsn

Table 18. Hub Interface Signals

	Buffer Type/I/O	Signal Type	State During RSTIN# Assertion	State After RSTIN# Deassertion	Pull Up/Pull Down	C3	S1M	S3	S4-S5	G3
HI_STB	CMOS	I/O	N/A	N/A	N/A	N/A	N/A	Pwrdsn	Pwrdsn	Pwrdsn
HI_STB#	CMOS	I/O	N/A	N/A	N/A	N/A	N/A	Pwrdsn	Pwrdsn	Pwrdsn
HI_[10:0]	CMOS	I/O	N/A	N/A	N/A	N/A	N/A	Pwrdsn	Pwrdsn	Pwrdsn

3. Register Description

3.1. Conceptual Overview of the Platform Configuration Structure

The Intel 845MP/845MZ Chipset MCH-M and ICH3-M are physically connected by hub interface A. From a configuration standpoint, the hub interface A is PCI bus #0. As a result, all devices internal to the MCH-M and ICH3-M appear to be on PCI bus #0. The system's primary PCI expansion bus is physically attached to the ICH3-M and from a configuration perspective, appears to be a hierarchical PCI bus behind a PCI-to-PCI bridge and therefore has a programmable PCI Bus number. **Note that the primary PCI bus is referred to as PCI_A in this document and is not PCI bus #0 from a configuration standpoint.** The AGP appears to system software to be a real PCI bus behind PCI-to-PCI bridges resident as devices on PCI bus #0.

The MCH-M contains two PCI devices within a single physical component. The configuration registers for the four devices are mapped as devices residing on PCI bus #0.

- Device 0: Host-hub interface Bridge/DRAM Controller. Logically this appears as a PCI device residing on PCI bus #0. Physically Device 0 contains the standard PCI registers, DRAM registers, the Graphics Aperture controller, and other MCH-M specific registers.
- Device 1: Host-AGP Bridge. Logically this appears as a "virtual" PCI-to-PCI bridge residing on PCI bus #0. Physically Device 1 contains the standard PCI-to-PCI bridge registers and the standard AGP/PCI configuration registers (including the AGP I/O and memory address mapping).

The following table shows the Device # assignment for the various internal MCH-M devices.

Table 19. Device Number Assignment

MCH-M Function	Bus #0, Device#
DRAM Controller/8 bit HI_A Controller	Device #0
Host-to-AGP Bridge (virtual P2P)	Device #1

NOTE: A physical PCI bus #0 does not exist. The hub interface and the internal devices in the Intel 845MP/845MZ Chipset MCH-M and ICH3-M logically constitute PCI Bus #0 to configuration software.

3.2. Standard PCI Bus Configuration Mechanism

The PCI Bus defines a slot based "configuration space" that allows each device to contain up to 8 functions with each function containing up to 256 8-bit configuration registers. The PCI specification defines two bus cycles to access the PCI configuration space: Configuration Read and Configuration Write. Memory and I/O spaces are supported directly by the CPU. Configuration space is supported by a mapping mechanism implemented within the MCH-M. The PCI specification defines two mechanisms to access configuration space, Mechanism #1 and Mechanism #2. The MCH-M supports only Mechanism #1.

The configuration access mechanism makes use of the CONFIG_ADDRESS Register (at I/O address 0CF8h though 0CFBh) and CONFIG_DATA Register (at I/O address 0CFCh though 0CFFh). To reference a configuration register a Dword I/O write cycle is used to place a value into CONFIG_ADDRESS that specifies the PCI bus, the device on that bus, the function within the device, and a specific configuration register of the device function being accessed. CONFIG_ADDRESS[31] must be 1 to enable a configuration cycle. CONFIG_DATA then becomes a window into the four bytes of configuration space specified by the contents of CONFIG_ADDRESS. Any read or write to CONFIG_DATA will result in the MCH-M translating the CONFIG_ADDRESS into the appropriate configuration cycle.

The MCH-M is responsible for translating and routing the CPU's I/O accesses to the CONFIG_ADDRESS and CONFIG_DATA registers to internal MCH-M configuration registers, hub interface, or AGP.

3.3. Routing Configuration Accesses

The MCH-M supports two bus interfaces: the hub interface and AGP. PCI configuration cycles are selectively routed to one of these interfaces. The MCH-M is responsible for routing PCI configuration cycles to the proper interface. PCI configuration cycles to the ICH3-M internal devices, and Primary PCI (including downstream devices) are routed to the ICH3-M via the hub interface. AGP configuration cycles are routed to AGP. The AGP interface is treated as a separate PCI bus from the configuration point of view. Routing of configuration AGP is controlled via the standard PCI-PCI bridge mechanism using information contained within the PRIMARY BUS NUMBER, the SECONDARY BUS NUMBER, and the SUBORDINATE BUS NUMBER registers of the corresponding PCI-PCI bridge device.

A detailed description of the mechanism for translating CPU I/O bus cycles to configuration cycles on one of the buses is described below.

3.3.1. PCI Bus #0 Configuration Mechanism

The MCH-M decodes the Bus Number (bits 23:16) and the Device Number fields of the CONFIG_ADDRESS register. If the Bus Number field of CONFIG_ADDRESS is 0 the configuration cycle is targeting a PCI Bus #0 device.

- The Host-HI Bridge entity within the MCH-M is hardwired as Device #0 on PCI Bus #0.
- The Host-AGP Bridge entity within the MCH-M is hardwired as Device #1 on PCI Bus #0.

Configuration cycles to any of the MCH-M's internal devices are confined to the MCH-M and not sent over hub interface. Accesses to disabled MCH-M internal devices will be forwarded over the hub interface as Type0 Configuration Cycles.

3.3.2. Primary PCI and Downstream Configuration Mechanism

If the Bus Number in the CONFIG_ADDRESS is non-zero, and is less than the value in the Host-AGP device's SECONDARY BUS NUMBER register, or greater than the value in the Host-AGP device's SUBORDINATE BUS NUMBER register, the MCH-M will generate a Type 1 hub interface Configuration Cycle. The ICH3-M compares the non-zero Bus Number with the SECONDARY BUS NUMBER and SUBORDINATE BUS NUMBER registers of its P2P bridges to determine if the configuration cycle is meant for Primary PCI or a downstream PCI bus.

3.3.3. AGP Configuration Mechanism

From the chipset configuration perspective, AGP is seen as a PCI bus interface residing on a Secondary Bus side of the “virtual” PCI-PCI bridges referred to as the MCH-M Host-AGP bridge. On the Primary Bus side, the “virtual” PCI-PCI bridge is attached to PCI Bus #0. Therefore, the PRIMARY BUS NUMBER register is hardwired to “0”. The “virtual” PCI-PCI bridge entity converts Type #1 PCI Bus Configuration cycles on PCI Bus #0 into Type 0 or Type 1 configuration cycles on the AGP interface. Type 1 configuration cycles on PCI Bus #0 that have a BUS NUMBER that matches the SECONDARY BUS NUMBER of the MCH-M’s “virtual” Host-to-PCI_B/AGP bridge will be translated into Type 0 configuration cycles on the AGP interface.

If the Bus Number is non-zero, greater than the value programmed into the SECONDARY BUS NUMBER register, and less than or equal to the value programmed into the SUBORDINATE BUS NUMBER register, the MCH-M will generate a Type 1 PCI configuration cycle on AGP.

3.4. MCH-M Register Introduction

The MCH-M contains two sets of software accessible registers, accessed via the Host CPU I/O address space:

1. Control registers I/O mapped into the CPU I/O space, which control access to PCI and AGP configuration space (see section entitled I/O Mapped Registers).
2. Internal configuration registers residing within the MCH-M are partitioned into four logical device register sets (“logical” since they reside within a single physical device). The first register set is dedicated to Host-HI Bridge functionality (i.e. DRAM configuration, other chip-set operating parameters and optional features). The second register block is dedicated to Host-AGP Bridge functions (controls AGP interface configurations and operating parameters).

The MCH-M supports PCI configuration space accesses using the mechanism denoted as Configuration Mechanism #1 in the PCI specification.

The MCH-M internal registers (I/O Mapped and Configuration registers) are accessible by the Host CPU. The registers can be accessed as Byte, Word (16-bit), or Dword (32-bit) quantities, with the exception of CONFIG_ADDRESS, which can only be accessed as a Dword. All multi-byte numeric fields use “little-endian” ordering (i.e., lower addresses contain the least significant parts of the field).

Reserved Bits:

Some of the MCH-M registers described in this section contain reserved bits. These bits are labeled “Reserved”. Software must deal correctly with fields that are reserved. On reads, software must use appropriate masks to extract the defined bits and not rely on reserved bits being any particular value. On writes, software must ensure that the values of reserved bit positions are preserved. That is, the values of reserved bit positions must first be read, merged with the new values for other bit positions and then written back. Note the software does not need to perform read, merge, and write operation for the configuration address register.

Reserved Registers:

In addition to reserved bits within a register, the MCH-M contains address locations in the configuration space of the Host-HI Bridge entity that are marked either “Reserved” or “Intel Reserved”. When a

“Reserved” register location is read, a random value is returned. (“Reserved” registers can be 8-bit, 16-bit, or 32-bit in size.) Writes to “Intel Reserved” registers may cause system failure. Reads to “Intel Reserved” registers may return a non-zero value.

Default Value Upon Reset:

Upon a full Reset, the MCH-M sets all of its internal configuration registers to predetermined default states. Some register values at reset are determined by external strapping options. The default state represents the minimum functionality feature set required to successfully bring up the system. Hence, it does not represent the optimal system configuration. It is the responsibility of the system initialization software (usually BIOS) to properly determine the DRAM configurations, operating parameters and optional system features that are applicable, and to program the MCH-M registers accordingly.

3.5. I/O Mapped Registers

The MCH-M contains two registers that reside in the CPU I/O address space: the Configuration Address (CONFIG_ADDRESS) Register and the Configuration Data (CONFIG_DATA) Register. The Configuration Address Register enables/disables the configuration space and determines what portion of configuration space is visible through the Configuration Data window.

3.5.1. CONFIG_ADDRESS – Configuration Address Register

I/O Address: 0CF8h Accessed as a Dword
Default Value: 00000000h
Access: Read/Write
Size: 32 bits

CONFIG_ADDRESS is a 32-bit register that can be accessed only as a Dword. A Byte or Word reference will "pass through" the Configuration Address Register and the hub interface, onto the PCI bus as an I/O cycle. The CONFIG_ADDRESS register contains the Bus Number, Device Number, Function Number, and Register Number for which a subsequent configuration access is intended.

Figure 2. Configuration Address Register

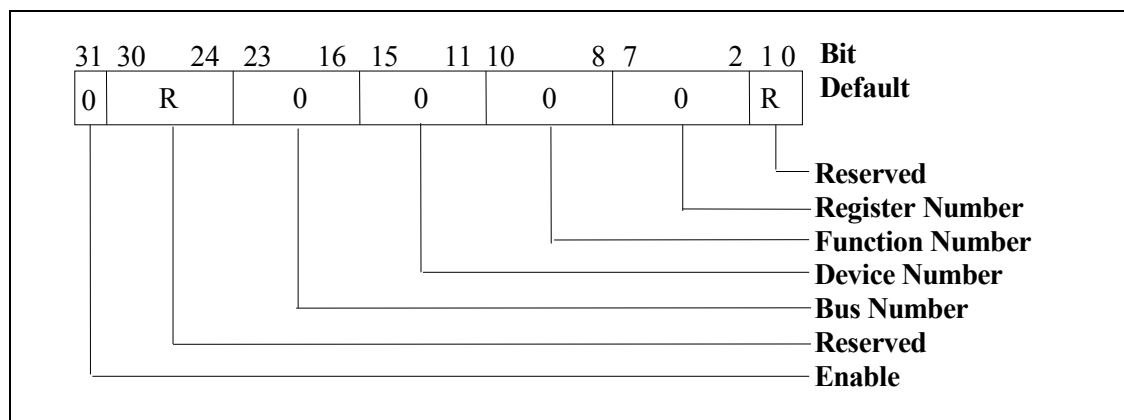

Bit	Descriptions
31	Configuration Enable (CFGE): When this bit is set to 1, accesses to PCI configuration space are enabled. If this bit is reset to 0, accesses to PCI configuration space are disabled.
30:24	Reserved (These bits are read only and have a value of 0).
23:16	<p>Bus Number: When the Bus Number is programmed to 00h the target of the Configuration Cycle is a hub interface agent (MCH-M, ICH3-M, etc.).</p> <p>The Configuration Cycle is forwarded to hub interface if the Bus Number is programmed to 00h and the MCH-M is not the target (the device number is >= 2).</p> <p>If the Bus Number is non-zero and matches the value programmed into the SECONDARY BUS NUMBER Register of device #1, a Type 0 PCI configuration cycle will be generated on AGP.</p> <p>If the Bus Number is non-zero, greater than the value in the SECONDARY BUS NUMBER register of device #1 and less than or equal to the value programmed into the SUBORDINATE BUS NUMBER Register of device #1 a Type 1 PCI configuration cycle will be generated on AGP.</p> <p>If the Bus Number is non-zero, and does not fall within the ranges enumerated by device #1's SECONDARY BUS NUMBER or SUBORDINATE BUS NUMBER Register, then a hub interface Type 1 Configuration Cycle is generated.</p>
15:11	<p>Device Number: This field selects one agent on the PCI bus selected by the Bus Number. When the Bus Number field is "00" the MCH-M decodes the Device Number field. The MCH-M is always Device Number 0 for the Host-hub interface bridge entity and Device Number 1 for the Host-AGP entity. Therefore, when the Bus Number =0 and the Device Number=0-1 the internal MCH-M devices are selected.</p> <p>If the Bus Number is non-zero and matches the value programmed into the SECONDARY BUS NUMBER Register, a Type 0 PCI configuration cycle will be generated on AGP. The MCH-M will decode the Device Number field[15:11] and assert the appropriate GAD signal as an IDSEL. For PCI-to-PCI Bridge translation, one of the 16 IDSELS is generated. When bit [15] = 0 bits [14:11] are decoded to assert a signal AD[31:16] IDSEL. GAD16 is asserted to access Device #0, GAD17 for Device #1 and so forth up to Device #15 for which will assert AD31. All device numbers higher than 15 cause a type 0 configuration access with no IDSEL asserted, which will result in a Master Abort reported in the MCH-M's "virtual" PCI-PCI bridge registers.</p> <p>For Bus Numbers resulting in hub interface configuration cycles, the MCH-M propagates the device number field as A[15:11]. For bus numbers resulting in AGP type 1 configuration cycles, the device number is propagated as GAD[15:11].</p>
10:8	Function Number: This field is mapped to GAD[10:8] during AGP Configuration cycles and A[10:8] during hub interface configuration cycles. This allows the configuration registers of a particular function in a multi-function device to be accessed. The MCH-M ignores configuration cycles to its internal Devices if the function number is not equal to 0.
7:2	Register Number: This field selects one register within a particular Bus, Device, and Function as specified by the other fields in the Configuration Address Register. This field is mapped to GAD[7:2] during AGP Configuration cycles and A[7:2] during hub interface Configuration cycles.
1:0	Reserved

3.5.2. CONFIG_DATA - Configuration Data Register

I/O Address: 0CFCh
Default Value: 0000000h
Access: Read/Write
Size: 32 bits

CONFIG_DATA is a 32-bit read/write window into configuration space. The portion of configuration space that is referenced by CONFIG_DATA is determined by the contents of CONFIG_ADDRESS.

Figure 3. Configuration Data Register

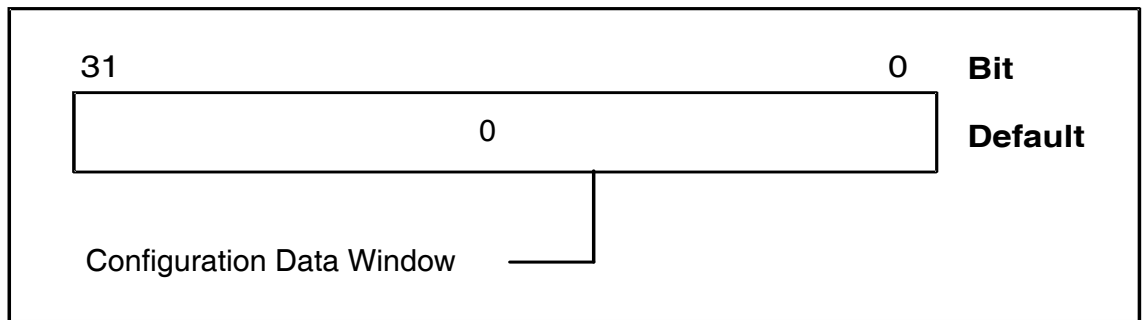

Bit	Descriptions
31:0	Configuration Data Window (CDW). If bit 31 of CONFIG_ADDRESS is 1 any I/O access that to the CONFIG_DATA register will be mapped to configuration space using the contents of CONFIG_ADDRESS.

3.6. Memory Mapped Register Space

All System Memory control functions have been consolidated into a new memory mapped address region within Device 0 Function 0. This space will be accessed using a new Base Address Register (BAR) located at Dev 0 Func 0 (Offset 14h). By default this BAR will be invisible (i.e., Read-Only zeros).

Note: All accesses to these Memory Mapped Registers must be made as a single DWORD (4 bytes) or less. Access must be aligned on a natural boundary.

The high-level breakout of these memory-mapped registers is as follows.

Address	Register Group
020h-02Bh	Reserved
2Ch	DRAM Width Register
02Dh-02Fh	Reserved
030h-034h	Strength Registers
040h-0DFh	Reserved
140h-1DFh	Reserved

3.6.1. DRAMWIDTH—DRAM Width Register

Address Offset: 2Ch
Default Value: 00h
Access: R/W
Size: 8 bits

This register determines the width of SDRAM devices populated in each row of memory.

Bit	Descriptions
7:4	Reserved.
3	Row 3 Width. Width of devices in Row 3 0 = 16-bit wide devices, or Unpopulated (default) 1 = 8-bit wide devices
2	Row 2 Width. Width of devices in Row 2 0 = 16-bit wide devices, or Unpopulated (default) 1 = 8-bit wide devices
1	Row 1 Width. Width of devices in Row 1 0 = 16-bit wide devices, or Unpopulated (default) 1 = 8-bit wide devices
0	Row 0 Width. Width of devices in Row 0 0 = 16-bit wide devices, or Unpopulated (default) 1 = 8-bit wide devices

Note: Since there are multiple clock signals assigned to each row of a DIMM, it is important to clarify exactly which row width field affects which clock signal.

Row Parameters	DDR Clocks Affected
0	SCK[2:0]/SCK[2:0]#
1	SCK[2:0]/SCK[2:0]#
2	SCK[5:3]/SCK[5:3]#
3	SCK[5:3]/SCK[5:3]#

3.6.2. DQCMDSTR – Strength Control Register for DQ and CMD Signal Groups

Address Offset: 30h
Default Value: 00h
Access: Read Only, Read/Write
Size: 8 bits

This register controls the drive strength of the I/O buffers for the DQ/DQS and CMD signal groups.

Bit	Descriptions
7	Reserved
6:4	CMD Strength Control (RAS#, CAS#, WE#, MA[12:0], BS[1:0]) 000 = 0.75 X (default) 001 = 1.00 X 010 = 1.25 X 011 = 1.50 X 100 = 2.00 X 101 = 2.50 X 110 = 3.00 X 111 = 4.00 X
3	Reserved
2:0	DQ/DQS Strength Control: Sets drive strength as shown below: 000 = 0.75 X (default) 001 = 1.00 X 010 = 1.25 X 011 = 1.50 X 100 = 2.00 X 101 = 2.50 X 110 = 3.00 X 111 = 4.00 X

3.6.3. CKESTR – Strength Control Register for CKE Signal Group

Address Offset: 31h
Default Value: 00h
Access: Read Only, Read/Write
Size: 8 bits

This register controls the drive strength of the I/O buffers for the CKE signal group. This group has two possible loadings depending on the width of SDRAM devices used in each Row of memory (x8 or x16). The proper strength can be independently programmed for each configuration. The actual strength used for each signal is determined by the DRAM Width Register (offset 2Ch).

Bit	Descriptions
7	Reserved
6:4	CKE x16 Strength Control: Sets drive strength as shown below 000 = 0.75 X (default) 001 = 1.00 X 010 = 1.25 X 011 = 1.50 X 100 = 2.00 X 101 = 2.50 X 110 = 3.00 X 111 = 4.00 X
3	Reserved.
2:0	CKE x8 Strength Control: Sets drive strength as shown below: 000 = 0.75 X (default) 001 = 1.00 X 010 = 1.25 X 011 = 1.50 X 100 = 2.00 X 101 = 2.50 X 110 = 3.00 X 111 = 4.00 X

3.6.4. CSBSTR – Strength Control Register for CS# Signal Group

Address Offset:	32h
Default Value:	00h
Access:	Read Only, Read/Write
Size:	8 bits

This register controls the drive strength of the I/O buffers for the CS# signal group. This group has two possible loadings depending on the width of SDRAM devices used in each Row of memory (x8 or x16). The proper strength can be independently programmed for each configuration. The actual strength used for each signal is determined by the DRAM Width register (offset 2Ch).

Bit	Descriptions
7	Reserved
6:4	CS# x16 Strength Control: Sets drive strength as shown below: 000 = 0.75 X (default) 001 = 1.00 X 010 = 1.25 X 011 = 1.50 X 100 = 2.00 X 101 = 2.50 X 110 = 3.00 X 111 = 4.00 X
3	Reserved
2:0	CS# x8 Strength Control: Sets drive strength as shown below: 000 = 0.75 X (default) 001 = 1.00 X 010 = 1.25 X 011 = 1.50 X 100 = 2.00 X 101 = 2.50 X 110 = 3.00 X 111 = 4.00 X

3.6.5. CKSTR – Strength Control Register for CK Signal Group (CK / CK#)

Address Offset: 33h
Default Value: 00h
Access: Read Only, Read/Write
Size: 8 bits

This register controls the drive strength of the I/O buffers for the CK signal group, which includes both the CK and CK# signals. This group has two possible loadings depending on the width of SDRAM devices used in each Row of memory (x8 or x16). The proper strength can be independently programmed for each configuration. The actual strength used for each signal is determined by the DRAM Width register (offset 2Ch).

Bit	Descriptions
7	Reserved
6:4	CK x16 Strength Control: Sets drive strength as shown below: 000 = 0.75 X (default) 001 = 1.00 X 010 = 1.25 X 011 = 1.50 X 100 = 2.00 X 101 = 2.50 X 110 = 3.00 X 111 = 4.00 X
3	Reserved
2:0	CK x8 Strength Control: Sets drive strength as shown below: 000 = 0.75 X (default) 001 = 1.00 X 010 = 1.25 X 011 = 1.50 X 100 = 2.00 X 101 = 2.50 X 110 = 3.00 X 111 = 4.00 X

3.6.6. RCVENSTR – Strength Control Register for RCVENOUT# Signals

Address Offset:	34h
Default Value:	00h
Access:	Read Only, Read/Write
Size:	8 bits

This register controls the drive strength of the I/O buffers for the Receive Enable Out (RCVENOUT#) signal.

Bit	Descriptions
7:3	Reserved
2:0	RCVEnOut# Strength Control: Sets drive strength as shown below: 000 = 0.75 X (default) 001 = 1.00 X 010 = 1.25 X 011 = 1.50 X 100 = 2.00 X 101 = 2.50 X 110 = 3.00 X 111 = 4.00 X

3.7. Host-Hub Interface Bridge Device Registers – Device #0

Table 20 shows the access attributes for the configuration space. An “s” in the Default Value field means that a strap determines the power-up default value for that bit. Table 21 below summarizes the MCH-M configuration space for Device #0.

Table 20. Nomenclature for Access Attributes

RO	Read Only. If a register is read only, writes to this register have no effect.
R/W	Read/Write. A register with this attribute can be read and written.
R/W/L	Read/Write/Lock A register with this attribute can be read, written, and Lock.
R/WC	Read/Write Clear. A register bit with this attribute can be read and written. However, a write of a 1 clears (sets to 0) the corresponding bit and a write of a 0 has no effect.
R/WO	Read/Write Once. A register bit with this attribute can be written to only once after power up. After the first write, the bit becomes read only.
L	Lock. A register bit with this attribute becomes Read Only after a lock bit is set.

Table 21. MCH-M Configuration Space for Device #0

Address Offset	Register Symbol	Register Name	Default Value	Access
00-01h	VID	Vendor Identification	8086h	RO
02-03h	DID	Device Identification	1A30h	RO
04-05h	PCICMD	PCI Command Register	0006h	RO, R/W
06-07h	PCISTS	PCI Status Register	0090h	RO, R/WC
08h	RID	Revision Identification	Dependent on silicon revision	RO
09h		Reserved.		
0Ah	SUBC	Sub-Class Code	00h	RO
0Bh	BCC	Base Class Code	06h	RO
0Dh	MLT	Master Latency Timer	00h	RO
0Eh	HDR	Header Type	00h	RO
0Fh		Reserved.		
10-13h	APBASE	Aperture Base Configuration	00000008h	RO, R/W
14-2Bh		Reserved.		
2C-2Dh	SVID	Subsystem Vendor Identification	0000h	R/WO
2E-2Fh	SID	Subsystem Identification	0000h	R/WO
30-33h		Reserved.		
34h	CAPPTR	Capabilities Pointer	A0h	RO
35-50h		Reserved.		
51h	AGPM	AGP Miscellaneous Config	00h	RW
52-5Fh	Reserved.			
60-67h	DRB[0:7]	DRAM Row Boundary Registers	00h	R/W
68-6Fh		Reserved.		
70-73h	DRA[0:7]	DRAM Row Attribute Registers	00h	R/W
73-77h		Reserved.		
78-7Bh	DRT	DRAM Timing Register	00000010h	R/W
7C-7Fh	DRC	DRAM Controller Mode Register	0000h	R/W, RO
80-85h		Reserved.		
86h	DERRSYN	DRAM Error Syndrome Register	00h	RO
87-8Bh		Reserved.		
8C-8Fh	EAP	Error Address Pointer Register	00000000h	RO
90-96h	PAM[0:6]	Programmable Attribute Map Registers	000000000000h	RO, R/W
97h	FDHC	Fixed DRAM Hole Control Register	00h	RO, R/W
98-9Ch		Reserved		

Address Offset	Register Symbol	Register Name	Default Value	Access
9Dh	SMRAM	System Management RAM Control Register	02h	RO, R/W
9Eh	ESMRAMC	Extended System Mgmt RAM Control Register	38h	RO, R/W, RWC
9Fh		Reserved		
A0-A3h	ACAPID	AGP Capability Identifier	00200002h	RO
A4-A7h	AGPSTAT	AGP Status Register	1F000217h	RO
A8-Abh	AGPCMD	AGP Command Register	00000000h	RO, R/W
AC-Afh		Reserved		
B0-B3h	AGPCTRL	AGP Control Register	00000000h	RO, R/W
B4h	APSIZE	Aperture Size	00h	RO, R/W
B5-B7h		Reserved		
B8-BBh	ATTBASE	Aperture Translation Table Base Register	00000000h	RO, R/W
BCh	AMTT	AGP MTT Control Register	00h	RO, R/W
BDh	LPTT	AGP Low Priority Transaction Timer Register	00h	RO, R/W
BE-C3h		Reserved		
C4-C5h	TOM	Top of Low Memory Register	0000h	R/W
C6-C7h	MCHCFG	MCH-M Configuration Register	0000h	RO, R/W
C8-C9h	ERRSTS	Error Status Register	0000h	RO, R/W
CA-CBh	ERRCMD	Error Command Register	0000h	RO, R/W
CC-CDh	SMICMD	SMI Command Register	0000h	RO, R/W
CE-CFh	SCICMD	SCI Command Register	0000h	RO, R/W
D0-DDh		Reserved		
DE-DFh	SKPD	Scratchpad Data Register	0000h	RO, R/W
E0-E3h		Reserved		
E4-E7h	CAPID	Product Specific Capability ID	F104A009h	RO
E8-FFh		Reserved		

3.7.1. VID – Vendor Identification Register – Device#0

Address Offset: 00 - 01h
Default Value: 8086h
Attribute: Read Only
Size: 16 bits

The VID Register contains the vendor identification number. This 16-bit register combined with the Device Identification Register uniquely identifies any PCI device. Writes to this register have no effect.

Bit	Description
15:0	Vendor Identification Number. This is a 16-bit value assigned to Intel. Intel VID = 8086h.

3.7.2. DID – Device Identification Register – Device#0

Address Offset: 02 - 03h
Default Value: 1A 30h
Attribute: Read Only
Size: 16 bits

This 16-bit register combined with the Vendor Identification register uniquely identifies any PCI device. Writes to this register have no effect.

Bit	Description
15:0	Device Identification Number. This is a 16-bit value assigned to the MCH-M Host-hub interface Bridge Function #0.

3.7.3. PCICMD – PCI Command Register – Device #0

Address Offset: 04-05h
Default: 0006h
Access: Read/Write, Read Only
Size 16 bits

Since MCH-M Device #0 does not physically reside on PCI0 many of the bits are not implemented.

Bit	Descriptions
15:10	Reserved
9	Fast Back-to-Back Enable (RO). This bit controls whether or not the master can do fast back-to-back writes to different targets. Since device #0 is strictly a target this bit is not implemented and is hardwired to 0. Writes to this bit position have no effect.
8	SERR Enable (SERRE) (R/W). This bit is a global enable bit for Device #0 SERR messaging. The MCH-M does not have an SERR# signal. The MCH-M communicates the SERR# condition by sending an SERR message to the ICH3-M. If this bit is set to a 1, the MCH-M is enabled to generate SERR messages over hub interface for specific Device #0 error conditions that are individually enabled in the ERRCMD register. The error status is reported in the ERRSTS and PCISTS registers. If SERRE is reset to 0, then the SERR message is not generated by the MCH-M for Device #0. NOTE: This bit only controls SERR message for the Device #0. Device 1 has its own SERRE bits to control error reporting for error conditions occurring on their respective devices.
7	Address/Data Stepping (RO). Address/data stepping is not implemented in the MCH-M, and this bit is hardwired to 0. Writes to this bit position have no effect.
6	Parity Error Enable (PERRE) (R/W). PERR# is not implemented by the MCH-M, and this bit is hardwired to 0. Writes to this bit position have no effect.
5	VGA Palette Snoop (RO). The MCH-M does not implement this bit and it is hardwired to a 0. Writes to this bit position have no effect.
4	Memory Write and Invalidate Enable(MWIE) (RO). The MCH-M does not implement this bit and it is hardwired to a 0. Writes to this bit position have no effect.
3	Special Cycle Enable(SCE) (RO). The MCH-M does not implement this bit and it is hardwired to a 0. Writes to this bit position have no effect.
2	Bus Master Enable (BME) (RO). The MCH-M is always enabled as a master on hub interface A. This bit is hardwired to a "1". Writes to this bit position have no effect.
1	Memory Access Enable (MAE) (RO). The MCH-M always allows access to main memory. This bit is not implemented and is hardwired to 1. Writes to this bit position have no effect.
0	I/O Access Enable (IOAE) (RO). This bit is not implemented in the MCH-M and is hardwired to a 0. Writes to this bit position have no effect.

3.7.4. PCISTS – PCI Status Register – Device #0

Address Offset: 06-07h
Default Value: 0090h
Access: Read Only, Read/Write Clear
Size: 16 bits

PCISTS is a 16-bit status register that reports the occurrence of error events on Device #0's on the hub interface. Since MCH-M Device #0 is the host-to-hub interface **A bridge**, many of the bits are not implemented.

Bit	Description
15	Reserved
14	Signaled System Error (SSE) (R/WC). This bit is set to 1 when MCH-M Device #0 generates an SERR message over hub interface for any enabled Device #0 error condition. Device #0 error conditions are enabled in the PCICMD and ERRCMD registers. Device #0 error flags are read/reset from the PCISTS or ERRSTS registers. Software sets SSE to 0 by writing a 1 to this bit.
13	Received Master Abort Status (RMAS) (R/WC). This bit is set when the MCH-M generates a hub interface request that receives a Master Abort completion packet or Master Abort Special Cycle. Software clears this bit by writing a 1 to it.
12	Received Target Abort Status (RTAS) (R/WC). This bit is set when the MCH-M generates a hub interface request that receives a Target Abort completion packet or Target Abort Special Cycle. Software clears this bit by writing a 1 to it.
11	Signaled Target Abort Status (STAS) (RO). The MCH-M will not generate a Target Abort hub interface completion packet or Special Cycle. This bit is not implemented in the MCH-M and is hardwired to a 0. Writes to this bit position have no effect.
10:9	DEVSEL Timing (DEVT). Hub interface does not comprehend DEVSEL# protocol. These bits are hardwired to "00". Writes to these bit positions have no effect.
8	Master Data Parity Error Detected (DPD) (RO). PERR signaling and messaging are not implemented by the MCH-M therefore this bit is hardwired to 0. Writes to this bit position have no effect.
7	Fast Back-to-Back Capable (FB2B). This bit is hardwired to 1. Writes to this bit position have no effect.
6:5	Reserved
4	Capability List (CLIST) (RO). This bit is set to 1 to indicate to the configuration software that this device/function implements a list of new capabilities. A list of new capabilities is accessed via register CAPPTR at configuration address offset 34h. Register CAPPTR contains an offset pointing to the start address within configuration space of this device where the AGP Capability standard register resides.
3:0	Reserved

3.7.5. RID – Revision Identification Register – Device #0

Address Offset: 08h
Default Value: 00h
Access: Read Only
Size: 8 bits

This register contains the revision number of the MCH-M Device #0. These bits are read only and writes to this register have no effect.

Bit	Description
7:0	Revision Identification Number. This is an 8-bit value that indicates the revision identification number for the MCH-M Device #0. For the B-1 Stepping, this value is 05h.

3.7.6. SUBC – Sub-Class Code Register – Device #0

Address Offset: 0Ah
Default Value: 00h
Access: Read Only
Size: 8 bits

This register contains the Sub-Class Code for the MCH-M Device #0. This code is 00h indicating a Host Bridge device. The register is read only.

Bit	Description
7:0	Sub-Class Code (SUBC). This is an 8-bit value that indicates the category of Bridge into which the MCH-M falls. The code is 00h indicating a Host Bridge.

3.7.7. BCC – Base Class Code Register – Device #0

Address Offset: 0Bh
Default Value: 06h
Access: Read Only
Size: 8 bits

This register contains the Base Class Code of the MCH-M Device #0. This code is 06h indicating a Bridge device. This register is read only.

Bit	Description
7:0	Base Class Code (BASEC). This is an 8-bit value that indicates the Base Class Code for the MCH-M. This code has the value 06h, indicating a Bridge device.

3.7.8. MLT – Master Latency Timer Register – Device #0

Address Offset: 0Dh
Default Value: 00h
Access: Read Only
Size: 8 bits

The hub interface does not comprehend the concept of Master Latency Timer. Therefore, this register is not implemented.

Bit	Description
7:0	These bits are hardwired to 0. Writes have no effect.

3.7.9. HDR – Header Type Register – Device #0

Offset: 0Eh
Default: 00h
Access: Read Only
Size: 8 bits

This register identifies the header layout of the configuration space. No physical register exists at this location.

Bit	Description
7:0	This read only field always returns 0 when read and writes have no effect.

3.7.10. APBASE – Aperture Base Configuration Register – Device #0

Offset:	10-13h
Default:	0000_0008h
Access:	Read/Write, Read Only
Size:	32 bits

The APBASE is a standard PCI Base Address register that is used to set the base of the Graphics Aperture. The standard PCI Configuration mechanism defines the base address configuration register such that only a fixed amount of space can be requested (dependent on which bits are hardwired to “0” or behave as hardwired to “0”). To allow for flexibility (of the aperture), an additional register called APSIZE is used as a “back-end” register to control which bits of the APBASE will behave as hardwired to “0”. This register will be programmed by the MCH-M specific BIOS code that will run before any of the generic configuration software is run.

Note: Bit 9 of the MCH-MCFG register is used to prevent accesses to the aperture range before this register is initialized by the configuration software and the appropriate translation table structure has been established in the main memory.

Bit	Description
31:28	Upper Programmable Base Address (R/W). These bits are part of the aperture base set by configuration software to locate the base address of the graphics aperture. They correspond to bits [31:28] of the base address in the CPU's address space that will cause a graphics aperture translation to be inserted into the path of any memory read or write. Default = 0000
27:22	Middle “Hardwired”/Programmable Base Address: These bits are part of the aperture base set by configuration software to locate the base address of the graphics aperture. They correspond to bits [27:4] of the base address in the CPU's address space that will cause a graphics aperture translation to be inserted into the path of any memory read or write. These bits can behave as though they were hardwired to “0” if programmed to do so by the APSIZE bits of the APSIZE register. This will cause configuration software to understand that the granularity of the graphics aperture base address is either finer or coarser, depending upon the bits set by MCH-M-specific configuration software in APSIZE.
21:4	Lower “Hardwired”: This forces minimum aperture size selected by this register to be 4MB.
3	Prefetchable (RO). This bit is hardwired to “1” to identify the Graphics Aperture range as prefetchable as per the PCI Specification for the base address registers. <i>There are no side effects on reads, the device returns all bytes on reads regardless of the byte enables, and the MCH-M may merge processor writes into this range without causing errors.</i>
2:1	Type (RO). These bits determine addressing type and they are hardwired to “00” to indicate that address range defined by the upper bits of this register can be located anywhere in the 32-bit address space.
0	Memory Space Indicator (RO). Hardwired to “0” to identify aperture range as a memory range.

3.7.11. SVID – Subsystem Vendor ID – Device #0

Offset: 2C-2Dh
Default: 0000h
Access: Read/Write Once
Size: 16 bits

This value is used to identify the vendor of the subsystem.

Bit	Description
15:0	Subsystem Vendor ID (R/WO). The default value is 00h. This field should be programmed during boot-up. After this field is written once, it becomes read only.

3.7.12. SID – Subsystem ID – Device #0

Offset: 2E-2Fh
Default: 0000h
Access: Read/Write Once
Size: 16 bits

This value is used to identify a particular subsystem.

Bit	Description
15:0	Subsystem ID (R/WO). The default value is 00h. This field should be programmed during boot-up. After this field is written once, it becomes read only.

3.7.13. CAPPTR – Capabilities Pointer – Device #0

Offset: 34h
Default: E4h
Access: Read Only
Size: 8 bits

The CAPPTR provides the offset that is the pointer to the location where the AGP standard registers are located.

Bit	Description
7:0	Pointer to the start of AGP standard register block. This pointer tells software where it can find the beginning of the AGP register block. The value in this field is E4h.

3.7.14. AGPM- AGP Miscellaneous Configuration

Offset: 51h
Default: 00h
Access: Read/Write
Size: 8 bits

Bit	Description
7:2	Reserved
1	Aperture Access Global Enable (APEN): This bit is used to prevent access to the graphics aperture from any port (CPU, HI_A, or AGP/PCI_B) before the aperture range is established by the configuration software and the appropriate translation table in the main DRAM has been initialized. The default value is "0", so this field must be set after system is fully configured in order to enable aperture accesses.
0	Reserved

3.7.15. DRB[0:7] – DRAM Row Boundary Registers – Device #0

Offset: 60-67h
Default: 00h
Access: Read/Write
Size: 8 bits

The DRAM Row Boundary Register defines the upper boundary address of each pair of DRAM rows with a granularity of 32 MB. Each row has its own single-byte DRB register. For example, a value of 1 in DRB0 indicates that 32 MB of DRAM has been populated in the first row.

Row0: 60h
 Row1: 61h
 Row2: 62h

Row3: 63h
 Row4: 64h **
 Row5: 65h **
 Row6: 66h **
 Row7: 67h **

DRB0 = Total memory in row0 (in 32MB increments)

DRB1 = Total memory in row0 + row1 (in 32MB increments)

DRB3 = Total memory in row0 + row1 + row2 + row3 (in 32MB increments)

** When in DDR mode DRB[4:7] must be programmed with value contained in DRB3.

Each Row is represented by a byte. Each byte has the following format.

Bit	Description
7:0	DRAM Row Boundary Address: This 8-bit value defines the upper and lower addresses for each DRAM row. This 8-bit value is compared against a set of address lines to determine the upper address limit of a particular row.

3.7.16. DRA[0:7] – DRAM Row Attribute Registers – Device #0

Offset: 70-73h
Default: 00h
Access: Read/Write
Size: 8 bits

The **DRAM Row Attribute Register** defines the page sizes to be used when accessing different pairs of rows. Each nibble of information in the **DRA** registers describes the page size of a pair of rows:

- Row0, 1: 70h
- Row2, 3: 71h
- Row4, 5: 72h (Not Used; see note)
- Row6, 7: 73h (Not Used; see note)

Note: Must contain default value of 00h

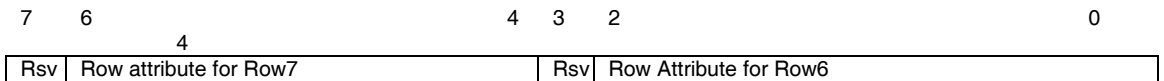
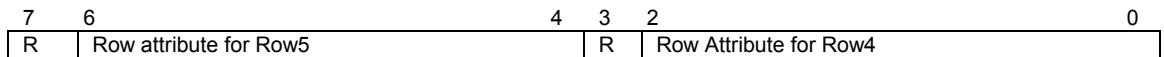
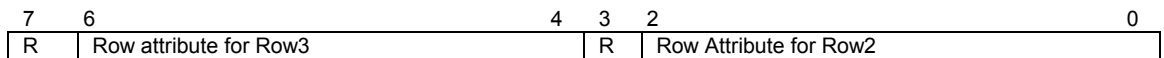
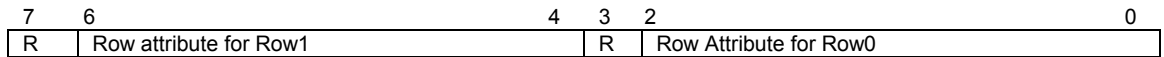

Bit	Description
7	Reserved
6:4	Row Attribute for odd-numbered row: This 3-bit field defines the page size of the corresponding row. 001: 2 KB 010: 4 KB 011: 8 KB 100: 16 KB Others: Reserved
3	Reserved
2:0	Row Attribute for even-numbered row: This 3-bit field defines the page size of the corresponding row. 001: 2 KB 010: 4 KB 011: 8 KB 100: 16 KB Others: Reserved

3.7.17. DRT – DRAM Timing Register – Device #0

Offset: 78-7Bh
Default: 0000010h
Access: Read/Write
Size: 32 bits

Bit	Description
31:19	Reserved
18:16	<p>DRAM Idle Timer: This field determines the number of clocks the DRAM controller will remain in the idle state before it begins precharging all pages.</p> <p> 000 <i>Infinite</i> 001 0 010 8 DRAM clocks 011 16 DRAM clocks 100 64 DRAM clocks Others: reserved </p>
15:11	Reserved
10:9	<p>Activate to Precharge delay (tRAS). This bit controls the number of DRAM clocks for tRAS.</p> <p> 00 7 Clocks 01 6 Clocks 10 5 Clocks 11 Reserved </p>
8:6	Reserved
5:4	<p>CAS# Latency (tCL). This bit controls the number of DRAM Clocks between when a read command is sampled by the SDRAMs and when the MCH-M samples read data from the SDRAMs.</p> <p> 00: 2.5 01: 2 Clocks 10: Reserved 11: Reserved </p>
3	Reserved
2	<p>DRAM RAS# to CAS# Delay (tRCD). This bit controls the number of clocks inserted between a row activate command and a read or write command to that row.</p> <p> Encoding tRCD 0: 3 DRAM Clocks (Default) 1: 2 DRAM Clocks </p>
1	Reserved
0	<p>DRAM RAS# Precharge (tRP). This bit controls the number of clocks that are inserted between a row precharge command and an activate command to the same row.</p> <p> Encoding tRP 0: 3 DRAM Clocks(Default) 1: 2 DRAM Clocks </p>

3.7.18. DRC – DRAM Controller Mode Register – Device #0

Offset: 7C-7Fh
Default: 0000000h
Access: Read/Write
Size: 32 bits

Bit	Description
31:30	Revision Number (REV): Reflects the revision number of the format used for DDR register definition. Currently, this field must be "00", since this (rev "00") is the only existing version of the specification.
29	Initialization Complete (IC): This bit is used for communication of software state between the memory controller and the BIOS. BIOS sets this bit to 1 after initialization of the DRAM memory array is complete.
28	<p>Dynamic Power-down mode Enable: When set, the DRAM controller will put pair of rows into power down mode when all banks are pre-charged (closed). Once a bank is accessed, the relevant pair of rows is taken out of Power Down mode.</p> <p>The entry into power down mode is performed by de-activation of CKE. The exit is performed by activation of CKE.</p> <p>0: DRAM Power-down disabled 1: DRAM Power-down enabled</p>
27:24	<p>Active DDR Rows: Implementations may use this field to limit the maximum number of DDR rows that may be active at once.</p> <p>0000 All rows allowed to be in the active state Others: Reserved.</p>
23:22	Reserved
21:20	<p>DRAM Data Integrity Mode (DDIM): These bits select one of 4 DRAM data integrity modes.</p> <p>DDIM Operation</p> <p>00 Non-ECC mode 10 Error checking with correction. Other Reserved</p>
19:11	Reserved
10:8	<p>Refresh Mode Select (RMS): This field determines whether refresh is enabled and, if so, at what rate refreshes will be executed.</p> <p>000: Refresh disabled 001: Refresh enabled. Refresh interval 15.6 μSec 010: Refresh enabled. Refresh interval 7.8 μsec 011: Refresh enabled. Refresh interval 64 μsec 111: Refresh enabled. Refresh interval 64 clocks (fast refresh mode) Other: Reserved</p>
7	Reserved

Bit	Description
6:4	<p>Mode Select (SMS). These bits select the special operational mode of the DRAM interface. The special modes are intended for initialization at power up.</p> <p>000: Post Reset state – When the MCH-M exits reset (power-up or otherwise), the mode select field is cleared to “000”.</p> <p>During any reset sequence, while power is applied and reset is active, the MCH-M asserts all CKE signals. After internal reset is de-asserted, CKE signals remain de-asserted until this field is written to a value different than “000”. On this event, all CKE signals are asserted.</p> <p>During suspend, MCH-M internal signal triggers DRAM controller to flush pending commands and enter all rows into Self-Refresh mode. As part of resume sequence, MCH-M will be reset – which will clear this bit field to “000” and maintain CKE signals de-asserted. After internal reset is de-asserted, CKE signals remain de-asserted until this field is written to a value different than “000”. On this event, all CKE signals are asserted.</p> <p>During entry to other low power states (C3, S1M), MCH-M internal signal triggers DRAM controller to flush pending commands and enter all rows into Self-Refresh mode. During exit to normal mode, MCH-M signal triggers DRAM controller to exit Self-Refresh and resume normal operation without S/W involvement.</p> <p>001: NOP Command Enable – All CPU cycles to DRAM result in a NOP command on the DRAM interface.</p> <p>010: All Banks Pre-charge Enable – All CPU cycles to DRAM result in an “all banks precharge” command on the DRAM interface.</p> <p>011: Mode Register Set Enable – All CPU cycles to DRAM result in a “mode register” set command on the DRAM interface. Host address lines are mapped to memory address lines in order to specify the command sent. Host address lines [15:3] are mapped to MA[12:0].</p> <p>100: Extended Mode Register Set Enable – All processor cycles to SDRAM result in an “extended mode register set” command on the DRAM interface (DDR only). Host address lines are mapped to DDR address lines in order to specify the command sent. Host address lines [15:3] are mapped to MA[12:0].</p> <p>101: Reserved</p> <p>110: CBR Refresh Enable – In this mode all CPU cycles to DRAM result in a CBR cycle on the DDR interface</p> <p>111: Normal operation</p>
3:0	Reserved

3.7.19. DERRSYN – DRAM Error Syndrome Register

Address Offset: 86h
Default Value: 00hb
Access: Read Only
Size: 8 bits

This register is used to report the ECC syndromes for each quadword of a 32-Byte aligned data quantity read from the DRAM array.

Bit	Description
7:0	<p>DRAM ECC Syndrome (DECCSYN) (RO): After a DRAM ECC error, hardware loads this field with a syndrome that describes the set of bits found to be in error.</p> <p>Note: that this field is locked from the time that it is loaded up to the time when the error flag is cleared by software. If the first error was a single bit, correctable error, then a subsequent multiple bit error will overwrite this field. In all other cases, an error that occurs after the first error and before the error flag has been cleared by software will escape recording.</p>

3.7.20. EAP – Error Address Pointer Register – Device #0

Address Offset: 8C-8Fh
Default Value: 0000_0000h
Access: Read Only
Size: 32 bits

This register stores the DRAM address when an ECC error occurs.

Bit	Description
31:30	Reserved
29:1	<p>Error Address Pointer (EAP): This field is used to store the 4-KB block of main memory of which an error (single bit or multi-bit error) has occurred.</p> <p>Note: that the value of this bit field represents the address of the first single or the first multiple bit error occurrence after the error flag bits in the ERRSTS register have been cleared by software. A multiple bit error will overwrite a single bit error. Once the error flag bits are set as a result of an error, this bit field is locked and doesn't change as a result of a new error.</p>
0	Reserved

3.7.21. PAM[0:6] – Programmable Attribute Map Registers – Device #0

Address Offset:	90-96h
Default Value:	00h
Attribute:	Read/Write, Read Only
Size:	8 bits

The MCH-M allows programmable memory attributes on 13 Legacy memory segments of various sizes in the 640 Kbytes to 1 Mbytes address range. Seven Programmable Attribute Map (PAM) Registers are used to support these features. Cacheability of these areas is controlled via the MTRR registers in the processor. Two bits are used to specify memory attributes for each memory segment. These bits apply to host initiator only access to the PAM areas. MCH-M will forward to main memory for any A.G.P., PCI, or hub interface A initiated accesses to the PAM areas. These attributes are:

RE - Read Enable. When RE = 1, the host read accesses to the corresponding memory segment are claimed by the MCH-M and directed to main memory. Conversely, when RE = 0, the host read accesses are directed to PCI0.

WE - Write Enable. When WE = 1, the host write accesses to the corresponding memory segment are claimed by the MCH-M and directed to main memory. Conversely, when WE = 0, the host write accesses are directed to PCI0.

The RE and WE attributes permit a memory segment to be Read Only, Write Only, Read/Write, or disabled. For example, if a memory segment has RE = 1 and WE = 0, the segment is Read Only.

Each PAM Register controls two regions, typically 16 Kbytes in size. Each of these regions has a 4-bit field. The four bits that control each region have the same encoding and are defined in the following table.

Table 22. Control Signals for Various Memory Segments

Bits [7, 3] Reserved	Bits [6, 2] Reserved	Bits [5, 1] WE	Bits [4, 0] RE	Description
X	x	0	0	Disabled. DRAM is disabled and all accesses are directed to the hub interface A. The MCH-M does not respond as a PCI target for any read or write access to this area.
X	x	0	1	Read Only. Reads are forwarded to DRAM and writes are forwarded to the hub interface A for termination. This write protects the corresponding memory segment. The MCH-M will respond as an AGP or the hub interface A target for read accesses but not for any write accesses.
X	x	1	0	Write Only. Writes are forwarded to DRAM and reads are forwarded to the hub interface for termination. The MCH-M will respond as an AGP or hub interface A target for write accesses but not for any read accesses.
X	x	1	1	Read/Write. This is the normal operating mode of main memory. Both read and write cycles from the host are claimed by the MCH-M and forwarded to DRAM. The MCH-M will respond as an AGP or the hub interface A target for both read and write accesses.

At the time that a hub interface or AGP accesses to the PAM region may occur, the targeted PAM segment must be programmed to be both readable and writeable.

As an example, consider BIOS that is implemented on the expansion bus. During the initialization process, the BIOS can be shadowed in main memory to increase the system performance. When BIOS is shadowed in main memory, it should be copied to the same address location. To shadow the BIOS, the attributes for that address range should be set to write only. The BIOS is shadowed by first doing a read of that address. This read is forwarded to the expansion bus. The host then does a write of the same address, which is directed to main memory. After the BIOS is shadowed, the attributes for that memory area are set to read only so that all writes are forwarded to the expansion bus. Figure 4 and Table 23 show the PAM registers and the associated attribute bits:

Figure 4. PAM Register Attributes

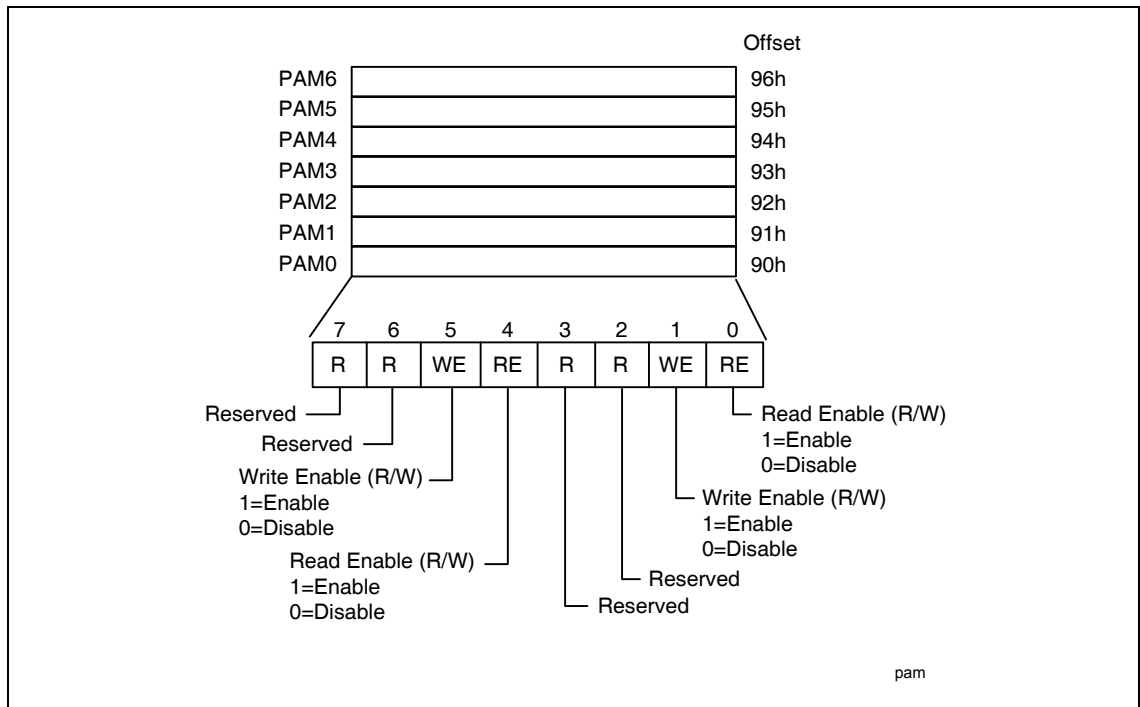

Table 23. PAM Register Details

PAM Reg	Attribute Bits				Memory Segment	Comments	Offset
	Reserved						90h
PAM0[3:0]							90h
PAM0[7:4]	R	R	WE	90h	0F0000h - 0FFFFFFh	BIOS Area	90h
PAM1[3:0]	R	R	WE	91h	0C0000h - 0C3FFFh	ISA Add-on BIOS	91h
PAM1[7:4]	R	R	WE	91h	0C4000h - 0C7FFFh	ISA Add-on BIOS	91h
PAM2[3:0]	R	R	WE	92h	0C8000h - 0CBFFFh	ISA Add-on BIOS	92h
PAM2[7:4]	R	R	WE	92h	0CC000h - 0CFFFFh	ISA Add-on BIOS	92h
PAM3[3:0]	R	R	WE	93h	0D0000h - 0D3FFFh	ISA Add-on BIOS	93h
PAM3[7:4]	R	R	WE	93h	0D4000h - 0D7FFFh	ISA Add-on BIOS	93h
PAM4[3:0]	R	R		94h	0D8000h - 0DBFFFh	ISA Add-on BIOS	94h
PAM4[7:4]	R	R	WE	94h	0DC000h - 0DFFFFh	ISA Add-on BIOS	94h
PAM5[3:0]	R	R	WE	95h	0E0000h - 0E3FFFh	BIOS Extension	95h
PAM5[7:4]	R	R	WE	95h	0E4000h - 0E7FFFh	BIOS Extension	95h
PAM6[3:0]	R	R	WE	96h	0E8000h - 0EBFFFh	BIOS Extension	96h
PAM6[7:4]	R	R	WE	96h	0EC000h - 0EFFFFh	BIOS Extension	96h

For details on overall system address mapping scheme see the Address Decoding Section of this document.

DOS Application Area (00000h-9FFFh)

The DOS area is 640 KB in size and it is further divided into two parts. The 512-KB area at 0 to 7FFFFh is always mapped to the main memory controlled by the MCH-M, while the 128-KB address range from 080000 to 09FFFFh can be mapped to PCI0 or to main DRAM. By default this range is mapped to main memory and can be declared as a main memory hole (accesses forwarded to PCI0) via MCH-M FDHC configuration register.

Video Buffer Area (A0000h-BFFFFh)

Attribute bits do not control this 128-KB area. The host -initiated cycles in this region are always forwarded to either PCI0 or AGP unless this range is accessed in SMM mode. **Routing of accesses is controlled by the Legacy VGA control mechanism of the “virtual” PCI-PCI bridge device embedded within the MCH-M.**

This area can be programmed as SMM area via a special configuration register. When used as SMM space this range cannot be accessed from the hub interface or AGP.

Expansion Area (C0000h-DFFFFh)

This 128-KB area is divided into eight 16-KB segments, which can be assigned with different attributes via PAM control register as defined by above.

Extended System BIOS Area (E0000h-EFFFFh)

This 64-Kbytes area is divided into four 16-Kbytes segments which can be assigned with different attributes via PAM control register as defined by the table above.

System BIOS Area (F0000h-FFFFFFh)

This area is a single 64-Kbytes segment, which can be assigned with different attributes via PAM control register as defined by the table above.

3.7.22. FDHC – Fixed DRAM Hole Control Register – Device #0

Address Offset:	97h
Default Value:	00h
Access:	Read/Write, Read Only
Size:	8 bits

This 8-bit register controls a fixed DRAM hole: 15 MB-16 MB.

Bit	Description				
7	<p>Hole Enable (HEN). This field enables a memory hole in DRAM space. Host cycles matching an enabled hole are passed on to ICH3-M through the hub interface. The hub interface cycles matching an enabled hole will be ignored by the MCH-M. Note that a selected hole is not re-mapped.</p> <table> <tr> <td>0</td> <td>Disabled. No hole</td> </tr> <tr> <td>1</td> <td>15 M-16 M (1 MB Hole)</td> </tr> </table>	0	Disabled. No hole	1	15 M-16 M (1 MB Hole)
0	Disabled. No hole				
1	15 M-16 M (1 MB Hole)				
6:0	Reserved				

3.7.23. SMRAM – System Management RAM Control Register – Device #0

Address Offset: 9Dh
Default Value: 02h
Access: Read/Write, Read Only, Lock
Size: 8 bits

The SMRAMC register controls how accesses to Compatible and Extended SMRAM spaces are treated. The Open, Close, and Lock bits function only when G_SMFRAME bit is set to a 1. Also, the OPEN bit must be reset before the LOCK bit is set.

Bit	Description
7	Reserved
6	SMM Space Open (D_OPEN): When D_OPEN=1 and D_LCK=0, the SMM space DRAM is made visible even when SMM decode is not active. This is intended to help BIOS initialize SMM space. Software should ensure that D_OPEN=1 and D_CLS=1 are not set at the same time. When D_LCK is set to a 1, D_OPEN is reset to 0 and becomes read only.
5	SMM Space Closed (D_CLS): When D_CLS = 1 SMM space DRAM is not accessible to data references, even if SMM decode is active. Code references may still access SMM space DRAM. This will allow SMM software to reference “through” SMM space to update the display even when SMM is mapped over the VGA range. Software should ensure that D_OPEN=1 and D_CLS=1 are not set at the same time. Note that the D_CLS bit only applies to Compatible SMM space.
4	SMM Space Locked (D_LCK): When D_LCK is set to 1 then D_OPEN is reset to 0 and D_LCK, D_OPEN, C_BASE_SEG, H_SMRAM_EN, TSEG_SZ and TSEG_EN become “Read Only”. D_LCK can be set to 1 via a normal configuration space write but can only be cleared by a Full Reset. The combination of D_LCK and D_OPEN provide convenience with security. The BIOS can use the D_OPEN function to initialize SMM space and then use D_LCK to “lock down” SMM space in the future so that no application software (or BIOS itself) can violate the integrity of SMM space, even if the program has knowledge of the D_OPEN function.
3	Global SMRAM Enable (G_SMFRAME). If set to a 1, then Compatible SMRAM functions is enabled, providing 128 KB of DRAM accessible at the A0000h address while in SMM (ADS# with SMM decode). To enable Extended SMRAM function this bit has to be set to 1. Once D_LCK is set, this bit becomes read only.
2:0	Compatible SMM Space Base Segment (C_BASE_SEG) (RO). This field indicates the location of SMM space. “SMM DRAM” is not remapped. It is simply “made visible” if the conditions are right to access SMM space, otherwise the access is forwarded to the hub interface. C_BASE_SEG is hardwired to 010 to indicate that the MCH-M supports the SMM space at A0000h-BFFFFh.

3.7.24. ESMRAMC – Extended System Mgmt RAM Control Register – Device #0

Address Offset: 9Eh
Default Value: 38h
Access: Read Only, Read/Write, Read/Write Clear, Lock
Size: 8 bits

The Extended SMRAM register controls the configuration of Extended SMRAM space. The Extended SMRAM (E_SMRAM) memory provides a write-back cacheable SMRAM memory space that is above 1 MByte.

Bit	Description										
7	<p>H_SMRAM_EN (H_SMRAME): Controls the SMM memory space location (i.e. above 1 MByte or below 1 MByte) When G_SMRAME is 1 and H_SMRAME this bit is set to 1, the high SMRAM memory space is enabled. SMRAM accesses from FEDA_0000h to FEDB_FFFFh are remapped to DRAM address 000A0000h to 000BFFFFh.</p> <p>Once D_LCK is set, this bit becomes read only.</p>										
6	<p>E_SMRAM_ERR (E_SMERR): This bit is set when host accesses the defined memory ranges in Extended SMRAM (High Memory and T-segment) while not in SMM space and with the D-OPEN bit = 0. It is software's responsibility to clear this bit. The software must write a 1 to this bit to clear it</p>										
5	<p>SMRAM_Cache (SM_CACHE): This bit is hardwired to '1'.</p>										
4	<p>SMRAM_L1_EN (SM_L1): This bit is hardwired to '1'.</p>										
3	<p>SMRAM_L2_EN (SM_L2): This bit is hardwired to '1'.</p>										
2:1	<p>TSEG_SZ[1:0] (T_SZ): Selects the size of the TSEG memory block if enabled. This memory is taken from the top of DRAM space (i.e. TOM - TSEG_SZ), which is no longer claimed by the memory controller (all accesses to this space are sent to the hub interface if TSEG_EN is set). This field decodes as follows:</p> <table border="1"> <thead> <tr> <th>TSEG_SZ[1,0]</th> <th>Description</th> </tr> </thead> <tbody> <tr> <td>00</td> <td>(TOM-128K) to TOM</td> </tr> <tr> <td>01</td> <td>(TOM-256K) to TOM</td> </tr> <tr> <td>10</td> <td>(TOM-512K) to TOM</td> </tr> <tr> <td>11</td> <td>(TOM-1M) to TOM (845MP Only)</td> </tr> </tbody> </table> <p>Once D_LCK is set, this bit becomes read only.</p>	TSEG_SZ[1,0]	Description	00	(TOM-128K) to TOM	01	(TOM-256K) to TOM	10	(TOM-512K) to TOM	11	(TOM-1M) to TOM (845MP Only)
TSEG_SZ[1,0]	Description										
00	(TOM-128K) to TOM										
01	(TOM-256K) to TOM										
10	(TOM-512K) to TOM										
11	(TOM-1M) to TOM (845MP Only)										
0	<p>TSEG_EN (T_EN): Enabling of SMRAM memory (TSEG, 128 Kbytes, 256 Kbytes, 512 Kbytes or 1 Mbytes of additional SMRAM memory) for Extended SMRAM space only. When G_SMRAME =1 and TSEG_EN = 1, the TSEG is enabled to appear in the appropriate physical address space.</p> <p>Once D_LCK is set, this bit becomes read only.</p>										

3.7.25. ACAPID – AGP Capability Identifier Register – Device #0

Address Offset: A0-A3h
Default Value: 0020_0002h
Access: Read Only
Size: 32 bits

This register provides standard identifier for AGP capability.

Bit	Description
31:24	Reserved.
23:20	Major AGP Revision Number (MAJREV): These bits provide a major revision number of AGP specification to which this version of MCH-M conforms. This field is hardwired to value of “0010b” (i.e. implying Rev 2.x).
19:16	Minor AGP Revision Number (MINREV): These bits provide a minor revision number of AGP specification to which this version of MCH-M conforms. This number is hardwired to value of “0000” (i.e. implying Rev x.0) Together with major revision number, this field identifies MCH-M as an AGP REV 2.0 compliant device.
15:8	Next Capability Pointer (NCAPTR): AGP capability is the first and the last capability described via the capability pointer mechanism and therefore these bits are hardwired to “0” to indicate the end of the capability linked list.
7:0	AGP Capability ID (CAPID): This field identifies the linked list item as containing AGP registers. This field has a value of 0000_0010b assigned by the PCI SIG.

3.7.26. AGPSTAT – AGP Status Register – Device #0

Address Offset: A4-A7h
Default Value: 1F00_0217h
Access: Read Only
Size: 32 bits

This register reports AGP device capability/status.

Bit	Description
31:24	Request Queue (RQ): This field is hardwired to 1Fh to indicate a maximum of 32 outstanding AGP command requests can be handled by the MCH-M. This field contains the maximum number of AGP command requests the MCH-M is configured to manage. Default =1Fh to allow a maximum of 32 outstanding AGP command requests.
23:10	Reserved
9	Side Band Addressing Support (SBA): This bit indicates that the MCH-M supports side band addressing. It is hardwired to 1.
8:6	Reserved
5	Greater than 4 GB Support (4GB): This bit indicates that the MCH-M does not support addresses greater than 4 gigabytes. It is hardwired to 0.
4	Fast Write Support (FW): This bit indicates that the MCH-M supports Fast Writes from the host to the AGP master. It is hardwired to a 1.
3	Reserved
2:0	Data Rate Support (RATE): After reset the MCH-M reports its data transfer rate capability. Bit 0 identifies if MCH-M supports 1x data transfer mode, bit 1 identifies if MCH-M supports 2x data transfer mode, and bit 2 identifies if MCH-M supports 4x data transfer mode. 1x, 2x, and 4x data transfer modes are supported by the MCH-M and therefore this bit field has a Default Value = 111. Note that the selected data transfer mode applies to both AD bus and SBA bus. It also applies to Fast Writes if they are enabled.

3.7.27. AGPCMD – AGP Command Register – Device #0

Address Offset: A8-ABh
Default Value: 0000_0000h
Access: Read/Write, Read Only
Size: 32 bits

This register provides control of the AGP operational parameters.

Bit	Description								
31:10	Reserved								
9	SBA Enable (SBAEN): When this bit is set to 1, the side band addressing mechanism is enabled.								
8	<p>AGP Enable (AGPEN): When this bit is reset to 0, the MCH-M will ignore all AGP operations, including the sync cycle. Any AGP operations received while this bit is set to 1 will be serviced even if this bit is subsequently reset to 0. If this bit transitions from a 1 to a 0 on a clock edge in the middle of an SBA command being delivered in 1X mode the command will be issued.</p> <p>0 = MCH-M will ignore all AGP operations, including the sideband strobe sync cycle.</p> <p>1 = MCH-M will respond to AGP operations delivered via PIPE#, or to operations delivered via SBA if the <i>AGP Side Band Enable</i> bit is also set to 1.</p>								
7:5	Reserved								
4	FW Enable (FWEN): When this bit is set, the MCH-M will use the Fast Write protocol for Memory Write transactions from the MCH-M to the AGP master. Fast Writes will occur at the data transfer rate selected by the data rate bits (2:0) in this register. When this bit is cleared, or when the data rate bits are set to 1x mode, the Memory Write transactions from the MCH-M to the AGP master use standard PCI protocol.								
3	Reserved								
2:0	<p>Data Rate (DRATE): The settings of these bits determine the AGP data transfer rate. One (and only one) bit in this field must be set to indicate the desired data transfer rate.</p> <table border="1"> <thead> <tr> <th>Encoding</th> <th>Description</th> </tr> </thead> <tbody> <tr> <td>0 0 1</td> <td>1x transfer mode</td> </tr> <tr> <td>0 1 0</td> <td>2x transfer mode</td> </tr> <tr> <td>1 0 0</td> <td>4x transfer mode</td> </tr> </tbody> </table> <p>Configuration software will update this field by setting only one bit that corresponds to the capability of AGP master (after that capability has been verified by accessing the same functional register within the AGP masters' configuration space.)</p> <p>NOTE: This field applies to G_AD and SBA buses. It also applies to Fast Writes if they are enabled.</p>	Encoding	Description	0 0 1	1x transfer mode	0 1 0	2x transfer mode	1 0 0	4x transfer mode
Encoding	Description								
0 0 1	1x transfer mode								
0 1 0	2x transfer mode								
1 0 0	4x transfer mode								

3.7.28. AGPCTRL – AGP Control Register

Address Offset: B0-B3h
Default Value: 0000_0000h
Access: Read/Write, Read Only
Size: 32 bits

This register provides for additional control of the AGP interface.

Bit	Description
31:8	Reserved
7	GTLB Enable (and GTLB Flush Control) (R/W): When this bit is set, it enables normal operations of the Graphics Translation Lookaside Buffer. If it is zero, the GTLB is flushed by clearing the valid bits associated with each entry. Default=0 (GTLB disabled)
6:0	Reserved

3.7.29. APSIZE – Aperture Size – Device #0

Address Offset: B4h
Default Value: 00h
Access: Read/Write, Read Only
Size: 8 bits

This register determines the effective size of the Graphics Aperture used for a particular MCH-M configuration. This register can be updated by the MCH-M specific BIOS configuration sequence before the PCI standard bus enumeration sequence takes place. If the register is not updated then a default value will select an aperture of maximum size (i.e. 256 MB). The size of the table that will correspond to a 256-MB aperture is not practical for most applications and therefore, these bits must be programmed to a smaller practical value that will force adequate address range to be requested via APBASE register from the PCI configuration software.

Bit	Description																																																								
7:6	Reserved																																																								
5:0	<p>Graphics Aperture Size (APSIZE) (R/W): Each bit in APSIZE[5:0] operates on similarly ordered bits in APBASE[27:22] of the Aperture Base configuration register. When a particular bit of this field is “0” it forces the similarly ordered bit in APBASE[27:22] to behave as “hardwired” to 0. When a particular bit of this field is set to “1” it allows the corresponding bit of the APBASE[27:22] field to be read/write accessible. Only the following combinations are allowed:</p> <table border="1"> <thead> <tr> <th>5</th> <th>4</th> <th>3</th> <th>2</th> <th>1</th> <th>0</th> <th>Aperture Size</th> </tr> </thead> <tbody> <tr> <td>1</td> <td>1</td> <td>1</td> <td>1</td> <td>1</td> <td>1</td> <td>4 MB</td> </tr> <tr> <td>1</td> <td>1</td> <td>1</td> <td>1</td> <td>1</td> <td>0</td> <td>8 MB</td> </tr> <tr> <td>1</td> <td>1</td> <td>1</td> <td>1</td> <td>0</td> <td>0</td> <td>16 MB</td> </tr> <tr> <td>1</td> <td>1</td> <td>1</td> <td>0</td> <td>0</td> <td>0</td> <td>32 MB</td> </tr> <tr> <td>1</td> <td>1</td> <td>0</td> <td>0</td> <td>0</td> <td>0</td> <td>64 MB</td> </tr> <tr> <td>1</td> <td>0</td> <td>0</td> <td>0</td> <td>0</td> <td>0</td> <td>128 MB</td> </tr> <tr> <td>0</td> <td>0</td> <td>0</td> <td>0</td> <td>0</td> <td>0</td> <td>256 MB</td> </tr> </tbody> </table> <p>Default for APSIZE[5:0]=000000b forces default APBASE[27:22] =000000b (i.e. all bits respond as “hardwired” to 0). This provides maximum aperture size of 256 MB. As another example, programming APSIZE[5:0]=111000b hardwires APBASE[24:22]=000b and while enabling APBASE[27:25] as read/write.</p>	5	4	3	2	1	0	Aperture Size	1	1	1	1	1	1	4 MB	1	1	1	1	1	0	8 MB	1	1	1	1	0	0	16 MB	1	1	1	0	0	0	32 MB	1	1	0	0	0	0	64 MB	1	0	0	0	0	0	128 MB	0	0	0	0	0	0	256 MB
5	4	3	2	1	0	Aperture Size																																																			
1	1	1	1	1	1	4 MB																																																			
1	1	1	1	1	0	8 MB																																																			
1	1	1	1	0	0	16 MB																																																			
1	1	1	0	0	0	32 MB																																																			
1	1	0	0	0	0	64 MB																																																			
1	0	0	0	0	0	128 MB																																																			
0	0	0	0	0	0	256 MB																																																			

3.7.30. **ATTBASE – Aperture Translation Table Base Register – Device #0**

Address Offset: B8-BBh
Default Value: 0000_0000h
Access: Read/Write, Read Only
Size: 32 bits

This register provides the starting address of the Graphics Aperture Translation Table Base located in the main DRAM. This value is used by the MCH-M Graphics Aperture address translation logic (including the GTLB logic) to obtain the appropriate address translation entry required during the translation of the aperture address into a corresponding physical DRAM address. The ATTBASE register may be dynamically changed.

Note: The address provided via ATTBASE is 4-KB aligned.

Bit	Description
31:12	Aperture Translation Table Base (TTABLE): This field contains a pointer to the base of the translation table used to map memory space addresses in the aperture range to addresses in main memory. NOTE: It should be modified only when the GTLB has been disabled.
11:0	Reserved

3.7.31. AMTT – AGP Interface Multi-Transaction Timer Register – Device #0

Address Offset: BCh
Default Value: 00h
Access: Read/Write, Read Only
Size: 8 bits

AMTT is an 8-bit register that controls the amount of time that the MCH-M arbiter allows an AGP master to perform multiple back-to-back transactions. The MCH-M AMTT mechanism is used to optimize the performance of an AGP master (using PCI protocol operations) that performs multiple back-to-back transactions to fragmented memory ranges (and as a consequence it can not use long burst transfers). The AMTT mechanism applies to the host-AGP transactions as well and it guarantees to the processor a fair share of the AGP interface bandwidth.

The number of clocks programmed in the AMTT represents the guaranteed time slice (measured in 66-MHz clocks) allotted to the current agent (either AGP master or Host bridge) after which the AGP arbiter may grant the bus to another agent. The default value of AMTT is 00h and disables this function. The AMTT value can be programmed with 8-clock granularity. For example, if the AMTT is programmed to 18h, then the selected value corresponds to the time period of 24 AGP (66 MHz) clocks.

Bit	Description
7:3	Multi-Transaction Timer Count Value (MTTC): The number programmed in these bits represents the guaranteed time slice (measured in eight 66-MHz clock granularity) allotted to the current agent (either AGP master or MCH-M) after which the AGP arbiter may grant the bus to another agent.
2:0	Reserved

3.7.32. LPTT – AGP Low Priority Transaction Timer Register – Device #0

Address Offset:	BDh
Default Value:	00h
Access:	Read/Write, Read Only
Size:	8 bits

LPTT is an 8-bit register similar in a function to AMTT. This register is used to control the minimum tenure on the AGP for low priority data transaction (both reads and writes) issued using PIPE# or SBA mechanisms.

The number of clocks programmed in the LPTT represents the guaranteed time slice (measured in 66 MHz clocks) allotted to the current low priority AGP transaction data transfer state. This does not necessarily apply to a single transaction, but can span multiple low-priority transactions of the same type. After this time expires the AGP arbiter may grant the bus to another agent if there is a pending request. The LPTT does not apply in the case of high-priority request where ownership is transferred directly to high-priority requesting queue. The default value of LPTT is 00h and disables this function. The LPTT value can be programmed with 8-clock granularity. For example, if the LPTT is programmed to 10h, then the selected value corresponds to the time period of 16 AGP (66 MHz) clocks.

Bit	Description
7:3	Low Priority Transaction Timer Count Value (LPTTC): The number of clocks programmed in these bits represents the guaranteed time slice (measured in eight 66-MHz clock granularity) allotted to the current low priority AGP transaction data transfer state.
2:0	Reserved

3.7.33. TOM – Top of Low Memory Register – Device #0

Address Offset: C4-C5h
Default Value: 0100h
Access: Read/Write
Size: 16 bits

This register contains the maximum address below 4 GB that should be treated as a memory access. Note that this register must be set to a value of 0100h (16 MB) or greater. Usually it will sit below the areas configured for the hub interface, PCI memory, and the graphics aperture.

Bit	Description
15:4	<p>Top of Low Memory (TOM): This register contains the address that corresponds to bits 31 to 20 of the maximum DRAM memory address that lies below 4 GB. Configuration software should set this value to either the maximum amount of memory in the system or to the minimum address allocated for PCI memory or the graphics aperture, whichever is smaller.</p> <p>Programming example: 400h = 1 GB. An access to 4000_0000h or above will be considered above the TOM and therefore not routed to DRAM. It may go to AGP, aperture, or subtractively decode to Hub Interface.</p>
3:0	Reserved

3.7.34. MCH-MCFG – MCH-M Configuration Register – Device #0

Offset: C6-C7h
Default: 0000h
Access: Read/Write Once, Read/Write, Read Only
Size: 16 bits

Bit	Description
15:12	Reserved
11	<p>System Memory Frequency Select: This bit must be programmed prior to memory initialization. This bit must be programmed/set to “0” prior to memory initialization in order to guarantee proper operation of the Intel®845MZ.</p> <p>0: System Memory frequency is set to 100 MHz</p> <p>1: System Memory frequency is set to 133 MHz (845MP only)</p>
10:6	Reserved
5	<p>Monochrome Display adapter Present (MDAP): This bit works with the VGA Enable bit in the BCTRL register of device 1 to control the routing of host initiated transactions targeting MDA compatible I/O and memory address ranges. This bit should not be set when the VGA Enable bit is not set in device 1 BCTRL1 register. When the MDAP bit is set, accesses to MDA resources are forwarded to hub interface A. MDA resources are defined as the following:</p> <p>Memory addresses: 0B0000h - 0B7FFFh</p> <p>I/O addresses: 3B4h, 3B5h, 3B8h, 3B9h, 3BAh, and 3BFh, including ISA address aliases, (A[15:10] are not used in decode)</p> <p>Any I/O reference that includes the I/O locations listed above, or their aliases, will be forwarded to the hub interface A even if the reference also includes I/O locations not listed above.</p> <p>Please refer to the System Address Map section of this document for further information.</p>
4:3	Reserved
2	<p>In-Order Queue Depth (IOQD): This bit reflects the value sampled on HA[7]# on the deassertion of the CPURST#. It indicates the depth of the host bus in-order queue (i.e. level of host bus pipelining). If IOQD is set to 1 (HA[7]# sampled “1” i.e. undriven on the host bus), then the depth of the host bus in-order queue is configured to the maximum allowed by the host bus protocol (i.e. 12). Note that the MCH-M has an 12 deep IOQ and will assert BNR# on the bus to limit the number of queued bus transactions to 12. If the IOQD bit is set to 0 (HA[7]# is sampled asserted, i.e., “0”), then depth of the host bus in-order queue is set to 1 (i.e. no pipelining support on the host bus).</p> <p>Note that HA[7]# is not driven by the MCH-M during CPURST#. If an IOQ size of 1 is desired, HA[7]# must be driven low during CPURST# by an external source.</p>
1	Reserved
0	Reserved

3.7.35. ERRSTS – Error Status Register – Device #0

Address Offset: C8-C9h
Default Value: 0000h
Access: Read Only, Read/Write Clear
Size: 16 bits

This register is used to report various error conditions via the hub interface messages to ICH3-M. An SERR, SMI, or SCI error message may be generated via the hub interface A on a zero to one transition of any of these flags when enabled in the PCICMD/ERRCMD, SMICMD, or SCICMD registers respectively. These bits are set regardless of whether or not the SERR is enabled and generated.

Bit	Description
15:10	Reserved
9	LOCK to non-DRAM Memory Flag (LCKF): When this bit is set it indicates that a host initiated LOCK cycle targeting non-DRAM memory space occurred. Software must write a “1” to clear this status bit.
8:7	Reserved
6	SERR on hub interface A Target Abort (TAHLA): When this bit is set, the MCH-M has detected that an MCH-M originated hub interface A cycle was terminated with a Target Abort completion packet or special cycle. Software must write a “1” to clear this bit.
5	MCH-M Detects Unimplemented hub interface Special Cycle (HIAUSC): When this bit is set the MCH-M detected an Unimplemented Special Cycle on the hub interface. Software must write a “1” to clear this bit.
4	AGP Access Outside of Graphics Aperture Flag (OOGF): When this bit is set it indicates that an AGP access occurred to an address that is outside of the graphics aperture range. Software must write a 1 to clear this status bit.
3	Invalid AGP Access Flag (IAAF): When this bit is set to 1 it indicates that an AGP access was attempted outside of the graphics aperture and either to the 640k-1M range or above top of the memory or illegal aperture access. Software must write a 1 to clear this status bit.
2	Invalid Graphics Aperture Translation Table Entry (ITTEF): When this bit is set to 1 it indicates that an invalid translation table entry was returned in response to an AGP access to the graphics aperture. Software must write a 1 to clear this bit.
1	Multiple-bit DRAM ECC Error Flag (DMERR): If this bit is set to 1, a memory read data transfer had an uncorrectable multiple-bit error. When this bit is set the address and device number that caused the error are logged in the EAP register. Software uses bits [1:0] to detect whether the logged error address is for Single or Multiple-bit error. Once software completes the error processing, a value of ‘1’ is written to this bit field to clear the value (back to 0) and unlock the error logging mechanism.
0	Single-bit DRAM ECC Error Flag (DSERR): If this bit is set to 1, a memory read data transfer had a single-bit correctable error and the corrected data was sent for the access. When this bit is set the address, channel number, and device number that caused the error are logged in the EAP register. Once this bit is set the EAP, CN, DN, and ES fields are locked to further single bit error updates until the processor clears this bit by writing a 1. Software must write a “1” to clear this bit and unlock the error logging mechanism.

3.7.36. ERRCMD – Error Command Register – Device #0

Address Offset:	CA-CBh
Default Value:	0000h
Access:	Read Only, Read/Write
Size:	16 bits

This register enables various errors to generate an SERR message via the hub interface A. Since the MCH-M does not have an SERR# signal, SERR messages are passed from the MCH-M to the ICH3-M over the hub interface. When a bit in this register is set, an SERR message will be generated on hub interface whenever the corresponding flag is set in the ERRSTS register. The actual generation of the SERR message is globally enabled for Device #0 via the PCI Command register.

Note: An error can generate one and only one error message via the hub interface A. It is software's responsibility to make sure that when an SERR error message is enabled for an error condition; SMI and SCI error messages are disabled for that same error condition.

Bit	Description
15:10	Reserved
9	SERR on Non-DRAM Lock (LCKERR): When this bit is asserted, the MCH-M will generate a hub interface A SERR special cycle whenever a processor lock cycle is detected that does not hit DRAM
8:7	Reserved
6	SERR on Target Abort on hub interface A Exception (TAHLA_SERR): When this bit is set, the generation of the hub interface A SERR message is enabled when an MCH-M originated hub interface A cycle is completed with "Target Abort" completion packet or special cycle status.
5	SERR on Detecting Hub Interface A Unimplemented Special Cycle (HIAUSCERR): When this bit is set to 1 the MCH-M generates an SERR message over hub interface A when an Unimplemented Special Cycle is received on the hub interface. When this bit is set to 0 the MCH-M does not generate an SERR message for this event. SERR messaging for Device 0 is globally enabled in the PCICMD register.
4	SERR on AGP Access Outside of Graphics Aperture (OOGF_SERR): When this bit is set, the generation of the hub interface A SERR message is enabled when an AGP access occurs to an address outside of the graphics aperture.
3	SERR on Invalid AGP Access (IAAF_SERR): When this bit is set, the generation of the hub interface A SERR message is enabled when an AGP access occurs to an address outside of the graphics aperture and either to the 640K - 1M range or above the top of memory.
2	SERR on Invalid Translation Table Entry (ITTEF_SERR): When this bit is set, the generation of the hub interface A SERR message is enabled when an invalid translation table entry was returned in response to an AGP access to the graphics aperture.
1	SERR Multiple-Bit DRAM ECC Error (DMERR_SERR): When this bit is set, the generation of the hub interface A SERR message is enabled when the MCH-M DRAM controller detects a multiple-bit error. For systems not supporting ECC this bit must be disabled.
0	SERR on Single-bit ECC Error (DSERR): When this bit is set, the generation of the hub interface A SERR message is enabled when the MCH-M DRAM controller detects a single bit error. For systems that do not support ECC this bit must be disabled.

3.7.37. SMICMD – SMI Command Register – Device #0

Address Offset: CC-CDh
Default Value: 0000h
Access: Read/Write, Read Only
Size: 16 bits

This register enables various errors to generate an SMI message via the hub interface A.

Note: An error can generate one and only one error message via the hub interface A. It is software’s responsibility to make sure that when an SMI error message is enabled for an error condition; SERR and SCI error messages are disabled for that same error condition.

Bit	Description
15:2	Reserved
1	SMI on Multiple-bit DRAM ECC Error (DMERR): When this bit is set, the generation of the hub interface A SMI message is enabled when the MCH-M DRAM controller detects a multiple-bit error. For systems not supporting ECC this bit must be disabled.
0	SMI on Single-bit ECC Error (DSERR): When this bit is set, the generation of the hub interface A SMI message is enabled when the MCH-M DRAM controller detects a single bit error. For systems that do not support ECC this bit must be disabled.

3.7.38. SCICMD – SCI Command Register – Device #0

Address Offset: CE-CDh
Default Value: 0000h
Access: Read/Write, Read Only
Size: 16 bits

This register enables various errors to generate a SCI message via the hub interface A.

Note: An error can generate one and only one error message via the hub interface A. It is software’s responsibility to make sure that when an SCI error message is enabled for an error condition, SERR and SMI error messages are disabled for that same error condition.

Bit	Description
15:2	Reserved
1	SCI on Multiple-Bit DRAM ECC Error (DMERR): When this bit is set, the generation of the hub interface A SCI message is enabled when the MCH-M DRAM controller detects a multiple-bit error. For systems not supporting ECC this bit must be disabled.
0	SCI on Single-bit ECC Error (DSERR): When this bit is set, the generation of the hub interface A SCI message is enabled when the MCH-M DRAM controller detects a single bit error. For systems that do not support ECC this bit must be disabled.

3.7.39. SKPD – Scratchpad Data – Device #0

Address Offset: DE-DFh
Default Value: 0000h
Access: Read/Write
Size: 16 bits

Bit	Description
15:0	Scratchpad [15:0]. These bits are simply R/W storage bits that have no affect on the MCH-M functionality.

3.7.40. CAPID – Product Specific Capability Identifier

Address Offset: E4h
Default Value: B104A009h
Access: Read Only
Size: 32 bits

Bit	Description
31	Dual Data Rate System Memory Capability 1 = Component supports Dual Data Rate (DDR) SDRAM memory.
30	Mobile Power Management Capability: 1 = Component is capable of all Mobile Power Management features. 0 = Component is NOT capable of all Mobile Power Management features
29	Reserved
28	System Memory Capability 1 = Component supports up to a 266-MHz DDR memory system, and more than 512 MB of maximum physical memory. 0 = Component supports 200-MHz DDR memory system, will support up to 512 MB of physical memory.
27:24	CAPID Version: This field has the value 0001b to identify the first revision f the CAPID register definition.
23:16	CAPID Length: This field has the value 04h to indicate the structure length (4 bytes).
15:8	Next Capability Pointer: This field has the value A0h to point to the next Capability ID in this device (ACAPID – AGP Capability ID Register).
7:0	CAP_ID: This field has the value 1001b to identify the CAP_ID assigned by the PCI SIG for vendor dependent capability pointers.

3.8. AGP Bridge Registers – Device #1

Table 24 shows the access attributes for configuration space.

Table 24. Nomenclature for Access Attributes

RO	Read Only. If a register is read only, writes to this register have no effect.
R/W	Read/Write. A register with this attribute can be read and written.
R/WC	Read/Write Clear. A register bit with this attribute can be read and written. However, a write of a 1 clears (sets to 0) the corresponding bit and a write of a 0 has no effect.

Table 25 summarizes the MCH-M configuration space for Device #1.

Table 25. MCH-M Configuration Space - Device #1

Address Offset	Register Symbol	Register Name	Default Value	Access
00-01h	VID1	Vendor Identification	8086h	RO
02-03h	DID1	Device Identification	1A31hh	RO
04-05h	PCICMD1	PCI Command Register	0000h	RO, R/W
06-07h	PCISTS1	PCI Status Register	00A0h	RO, R/WC
08	RID1	Revision Identification	Silicon Revision	RO
09		Reserved		
0Ah	SUBC1	Sub-Class Code	04h	RO
0Bh	BCC1	Base Class Code	06h	RO
0Ch		Reserved		
0Dh	MLT1	Master Latency Timer	00h	RO, R/W
0Eh	HDR1	Header Type	01h	RO
0F-17h		Reserved		
18h	PBUSN1	Primary Bus Number	00h	RO
19h	SBUSN1	Secondary Bus Number	00h	R/W
1Ah	SUBUSN1	Subordinate Bus Number	00h	R/W
1Bh	SMLT1	Secondary Bus Master Latency Timer	00h	RO, R/W
1Ch	IOBASE1	I/O Base Address Register	F0h	RO, R/W
1Dh	IOLIMIT1	I/O Limit Address Register	00h	RO, R/W
1E-1Fh	SSTS1	Secondary Status Register	02A0h	RO, R/WC
20-21h	MBASE1	Memory Base Address Register	FFF0h	RO, R/W
22-23h	MLIMIT1	Memory Limit Address Register	0000h	RO, R/W
24-25h	PMBASE1	Prefetchable Memory Base Address Reg.	FFF0h	RO, R/W

Address Offset	Register Symbol	Register Name	Default Value	Access
26-27h	PMLIMIT1	Prefetchable Memory Limit Address Reg.	0000h	RO, R/W
28-3Dh		Reserved		
3Eh	BCTRL1	Bridge Control Register	00h	RO, R/W
3Fh		Reserved		
40h	ERRCMD1	Error Command	00h	RO, R/W
41h-4Fh		Reserved		
50-57h	DWTMC	DRAM Write Thermal Mgnt. Control	00000000h	RWL
58-5Fh	DRTMC	DRAM Read Thermal Mgnt. Control	00000000h	RWL
59-FFh		Reserved		

3.8.1. VID1 – Vendor Identification Register – Device #1

Address Offset: 00 - 01h
Default Value: 8086h
Attribute: Read Only
Size: 16 bits

The VID Register contains the vendor identification number. This 16-bit register combined with the Device Identification Register uniquely identifies any PCI device. Writes to this register have no effect.

Bit	Description
15:0	Vendor Identification Number. This is a 16-bit value assigned to Intel. Intel VID = 8086h.

3.8.2. DID1 – Device Identification Register – Device #1

Address Offset: 02 - 03h
Default Value: 1A31h
Attribute: Read Only
Size: 16 bits

This 16-bit register combined with the Vendor Identification register uniquely identifies any PCI device. Writes to this register have no effect.

Bit	Description
15:0	Device Identification Number. This is a 16-bit value assigned to the MCH-M device #1. MCH-M1 device #1 DID =1A31h.

3.8.3. PCICMD1 – PCI-PCI Command Register – Device #1

Address Offset: 04-05h
Default: 0000h
Access: Read Only, Read/Write
Size 16 bits

Bit	Descriptions
15:10	Reserved
9	Fast Back-to-Back Enable (FB2BEn): Not Applicable. Hardwired to “0.”
8	<p>SERR Message Enable (SERRE1): This bit is a global enable bit for Device #1 SERR messaging. The MCH-M does not have an SERR# signal. The MCH-M communicates the SERR# condition by sending an SERR message to the ICH3-M. If this bit is set to a 1, the MCH-M is enabled to generate SERR messages over the hub interface for specific Device #1 error conditions that are individually enabled in the BCTRL register. The error status is reported in the PCISTS1 register. If SERRE1 is reset to 0, then the SERR message is not generated by the MCH-M for Device #1.</p> <p>NOTE: This bit only controls SERR messaging for the Device #1. Device #0 has its own SERRE bit to control error reporting for error conditions occurring on Device #0.</p>
7	Address/Data Stepping (ADSTEP): Not applicable. Hardwired to “0.”
6	Parity Error Enable (PERRE1): Parity checking is not supported on the primary side of this device. Hardwired to ‘0’
5	Reserved
4	Memory Write and Invalidate Enable (MWIE): This bit is implemented as Read Only and returns a value of 0 when read.
3	Special Cycle Enable (SCE): This bit is implemented as Read Only and returns a value of 0 when read.
2	Bus Master Enable (BME1): This bit is not functional. It is a RW bit for compatibility with compliance testing software.
1	Memory Access Enable (MAE1): This bit must be set to 1 to enable the Memory and Prefetchable memory address ranges defined in the MBASE1, MLIMIT1, PMBASE1, and PMLIMIT1 registers. When set to 0 all of device #1’s memory space is disabled.
0	I/O Access Enable (IOAE1): This bit must be set to 1 to enable the I/O address range defined in the IOBASE1, and IOLIMIT1 registers. When set to 0 all of device #1’s I/O space is disabled.

3.8.4. PCISTS1 – PCI-PCI Status Register – Device #1

Address Offset: 06-07h
Default Value: 00A0h
Access: Read Only, Read/Write Clear
Size: 16 bits

PCISTS1 is a 16-bit status register that reports the occurrence of error conditions associated with primary side of the “virtual” PCI-PCI bridge embedded within the MCH-M. Since this device does not physically reside on PCI_A it reports the optimum operating conditions so that it does not restrict the capability of PCI_A.

Bit	Descriptions
15	Detected Parity Error (DPE1): Not Applicable - hardwired to “0.”
14	Signaled System Error (SSE1): This bit is set to 1 when MCH-M Device #1 generates an SERR message over the hub interface A for any enabled Device #1 error condition. Device #1 error conditions are enabled in the ERRCMD, PCICMD1 and BCTRL1 registers. Device #1 error flags are read/reset from the ERRSTS and SSTS1 register. Software clears this bit by writing a 1 to it.
13	Received Master Abort Status (RMAS1): Not Applicable - hardwired to “0.”
12	Received Target Abort Status (RTAS1): Not Applicable - hardwired to “0.”
11	Signaled Target Abort Status (STAS1): Not Applicable - hardwired to “0.”
10:9	DEVSEL# Timing (DEVT1): This bit field is hardwired to “00b” to indicate that the device #1 uses the fastest possible decode.
8	Data Parity Detected (DPD1): Not Applicable - hardwired to “0”.
7	Fast Back-to-Back Capable (FB2B1): This bit is hardwired to “1” to indicate that the AGP port supports fast back to back transactions when the transactions are to different targets.
6	Reserved
5	66-MHz Capability (CAP66): This bit is hardwired to “1” to indicate that the AGP port is 66-MHz capable.
4:0	Reserved

3.8.5. RID1 – Revision Identification Register – Device #1

Address Offset:	08h
Default Value:	Dependent on Silicon Revision
Access:	Read Only
Size:	8 bits

This register contains the revision number of the MCH-M device #1. These bits are read only and writes to this register have no effect. For the A-0 stepping, this value is 00h.

Bit	Description
7:0	Revision Identification Number (RID): This is an 8-bit value that indicates the revision identification number for the MCH-M device #1.

3.8.6. SUBC1- Sub-Class Code Register – Device #1

Address Offset:	0Ah
Default Value:	04h
Access:	Read Only
Size:	8 bits

This register contains the Sub-Class Code for the MCH-M device #1. This code is 04h indicating a PCI-PCI Bridge device. The register is read only.

Bit	Description
7:0	Sub-Class Code (SUBC1): This is an 8-bit value that indicates the category of Bridge into which the MCH-M falls. The code is 04h indicating a Host Bridge.

3.8.7. BCC1 – Base Class Code Register – Device #1

Address Offset: 0Bh
Default Value: 06h
Access: Read Only
Size: 8 bits

This register contains the Base Class Code of the MCH-M device #1. This code is 06h indicating a Bridge device. This register is read only.

Bit	Description
7:0	Base Class Code (BASEC): This is an 8-bit value that indicates the Base Class Code for the MCH-M device #1. This code has the value 06h, indicating a Bridge device.

3.8.8. MLT1 – Master Latency Timer Register – Device #1

Address Offset: 0Dh
Default Value: 00h
Access: Read/Write
Size: 8 bits

This functionality is not applicable. It is described here since these bits should be implemented as a read/write to prevent standard PCI-PCI bridge configuration software from getting “confused.”

Bit	Description
7:3	Not applicable but supports read/write operations. (Reads return previously written data.)
2:0	Reserved

3.8.9. HDR1 – Header Type Register – Device #1

Offset: 0Eh
Default: 01h
Access: Read Only
Size: 8 bits

This register identifies the header layout of the configuration space.

Bit	Descriptions
7:0	This read only field always returns 01h when read. Writes have no effect.

3.8.10. PBUSN1 – Primary Bus Number Register – Device #1

Offset: 18h
Default: 00h
Access: Read Only
Size: 8 bits

This register identifies that “virtual” PCI-PCI Bridge is connected to bus #0.

Bit	Descriptions
7:0	Bus Number. Hardwired to “0.”

3.8.11. SBUSN1 – Secondary Bus Number Register – Device #1

Offset: 19h
Default: 00h
Access: Read /Write
Size: 8 bits

This register identifies the bus number assigned to the second bus side of the “virtual” PCI-PCI bridge i.e. to AGP. This number is programmed by the PCI configuration software to allow mapping of configuration cycles to AGP.

Bit	Descriptions
7:0	Bus Number. Programmable. Default = “00h”.

3.8.12. SUBUSN1 – Subordinate Bus Number Register – Device #1

Offset: 1Ah
Default: 00h
Access: Read /Write
Size: 8 bits

This register identifies the subordinate bus (if any) that resides at the level below AGP. This number is programmed by the PCI configuration software to allow mapping of configuration cycles to AGP.

Bit	Descriptions
7:0	Bus Number. Programmable. Default = “00h”.

3.8.13. SMLT1 – Secondary Master Latency Timer Register – Device #1

Address Offset: 1Bh
Default Value: 00h
Access: Read/Write, Read Only
Size: 8 bits

This register controls the bus tenure of the MCH-M on AGP. SMLT1 is an 8-bit register that controls the amount of time the MCH-M as an AGP/PCI bus master, can burst data on the AGP Bus. The Count Value is an 8-bit quantity, however SMLT1[2:0] are reserved and assumed to be 0 when determining the Count Value. The MCH-M's SMLT1 is used to guarantee the AGP master a minimum amount of system resources. When the MCH-M begins the first AGP FRAME# cycle after being granted the bus, the counter is loaded and enabled to count from the assertion of FRAME#. If the count expires while the MCH-M's grant is removed (due to an AGP master request), then the MCH-M will lose the use of the bus, and the AGP master may be granted the bus. If MCH-M's bus grant is not removed, the MCH-M will continue to own the AGP bus regardless of the SMLT1 expiration or idle condition.

The number of clocks programmed in the SMLT1 represents the guaranteed time slice (measured in 66-MHz AGP clocks) allotted to the MCH-M, after which it must complete the current data transfer phase and then surrender the bus as soon as its bus grant is removed. For example, if the SMLT1 is programmed to 18h, then the value is 24 AGP clocks. The default value of SMLT1 is 00h and disables this function. When the SMLT1 is disabled, the burst time for the MCH-M is unlimited (i.e. the MCH-M can burst forever).

Bit	Description
7:3	Secondary MLT counter value. Default=0, i.e. SMLT1 disabled
2:0	Reserved

3.8.14. IOBASE1 – I/O Base Address Register – Device #1

Address Offset: 1Ch
Default Value: F0h
Access: Read/Write, Read Only
Size: 8 bits

This register controls the hosts to AGP I/O access routing based on the following formula:

$$\text{IO_BASE} = \langle \text{address} \rangle \langle \text{IO_LIMIT} \rangle$$

Only the upper 4 bits are programmable. For the purpose of address decode address bits A[11:0] are treated as 0. Thus the bottom of the defined I/O address range will be aligned to a 4-KB boundary.

Bit	Description
7:4	I/O Address Base. Corresponds to A[15:12] of the I/O address. Default=Fh
3:0	Reserved

3.8.15. IOLIMIT1 – I/O Limit Address Register – Device #1

Address Offset: 1Dh
Default Value: 00h
Access: Read/Write, Read Only
Size: 8 bits

This register controls the hosts to AGP I/O access routing based on the following formula:

$$\text{IO_BASE} = \langle \text{address} \rangle \langle \text{IO_LIMIT} \rangle$$

Only the upper 4 bits are programmable. For the purpose of address decode address bits A[11:0] are assumed to be FFFh. Thus, the top of the defined I/O address range will be at the top of a 4-KB aligned address block.

Bit	Description
7:4	I/O Address Limit. Corresponds to A[15:12] of the I/O address. Default=0h
3:0	Reserved (Only 16-bit addressing supported)

3.8.16. SSTS1 – Secondary PCI-PCI Status Register – Device #1

Address Offset: 1E-1Fh
Default Value: 02A0h
Access: Read Only, Read/Write Clear
Size: 16 bits

SSTS1 is a 16-bit status register that reports the occurrence of error conditions associated with secondary side (i.e. AGP side) of the “virtual” PCI-PCI bridge embedded within MCH-M.

Bit	Descriptions
15	Detected Parity Error (DPE1): This bit is set to a 1 to indicate MCH-M’s detection of a parity error in the address or data phase of AGP bus transactions. Software sets DPE1 to 0 by writing a 1 to this bit.
14	Reserved
13	Received Master Abort Status (RMAS1): When the MCH-M terminates a Host-to-AGP with an unexpected master abort, this bit is set to 1. Software resets this bit to 0 by writing a 1 to it.
12	Received Target Abort Status (RTAS1): When an MCH-M-initiated transaction on AGP is terminated with a target abort, RTAS1 is set to 1. Software resets RTAS1 to 0 by writing a 1 to it.
11	Signaled Target Abort Status (STAS1): STAS1 is hardwired to a 0, since the MCH-M does not generate target abort on AGP.
10:9	DEVSEL# Timing (DEVT1): This 2-bit field indicates the timing of the DEVSEL# signal when the MCH-M responds as a target on AGP, and is hardwired to the value 01b (medium) to indicate the time when a valid DEVSEL# can be sampled by the initiator of the PCI cycle.
8	Master Data Parity Error Detected (DPD1): Hardwired to 0. MCH-M does not implement G_PERR# signal.
7	Fast Back-to-Back Capable (FB2B1): This bit is hardwired to 1, since MCH-M as a target supports fast back-to-back transactions to different targets on the AGP interface.
6	Reserved
5	66 MHz Capable (CAP66): This bit is hardwired to 1 to indicate that AGP bus is capable of 66-MHz operation.
4:0	Reserved

3.8.17. MBASE1 – Memory Base Address Register – Device #1

Address Offset:	20-21h
Default Value:	FFF0h
Access:	Read/Write, Read Only
Size:	16 bits

This register controls the host to AGP non-prefetchable memory accesses routing based on the following formula:

$$\text{MEMORY_BASE1} = \langle \text{address} \rangle \ll \text{MEMORY_LIMIT1}$$

The upper 12 bits of the register are read/write and correspond to the upper 12 address bits A[31:20] of the 32-bit address. The bottom 4 bits of this register are read-only and return zeros when read.

Configuration software must initialize this register. For the purpose of address decode, address bits A[19:0] are assumed to be 0. Thus, the bottom of the defined memory address range will be aligned to a 1-MB boundary.

Bit	Description
15:4	Memory Address Base 1 (MEM_BASE1). Corresponds to A[31:20] of the memory address.
3:0	Reserved

3.8.18. MLIMIT1 – Memory Limit Address Register – Device #1

Address Offset: 22-23h
Default Value: 0000h
Access: Read/Write, Read Only
Size: 16 bits

This register controls the host to AGP non-prefetchable memory accesses routing based on the following formula:

$$\text{MEMORY_BASE1} = \langle \text{address} \rangle \ll \text{MEMORY_LIMIT1}$$

The upper 12 bits of the register are read/write and correspond to the upper 12 address bits A[31:20] of the 32-bit address. The bottom 4 bits of this register are read-only and return zeros when read. The configuration software must initialize this register. For the purpose of address decode address bits A[19:0] are assumed to be FFFFh. Thus, the top of the defined memory address range will be at the top of a 1-MB aligned memory block.

Bit	Description
15:4	Memory Address Limit 1(MEM_LIMIT1). Corresponds to A[31:20] of the memory address. Default=000h
3:0	Reserved

Note: The memory range covered by MBASE1 and MLIMIT1 registers are used to map non-prefetchable AGP address ranges (typically where control/status memory-mapped I/O data structures of the graphics controller will reside), and PMBASE 1and PMLIMIT1 are used to map prefetchable address ranges (typically graphics local memory). This segregation allows application of USWC space attribute to be performed in a true plug-and-play manner to the prefetchable address range for improved host-AGP memory access performance.

3.8.19. PMBASE1 – Prefetchable Memory Base Address Register – Device #1

Address Offset:	24-25h
Default Value:	FFF0h
Access:	Read/Write, Read Only
Size:	16 bits

This register controls the host to AGP prefetchable memory accesses routing based on the following formula:

$$\text{PREFETCHABLE_MEMORY_BASE1} = \langle \text{address} \rangle = \langle \text{PREFETCHABLE_MEMORY_LIMIT1} \rangle$$

The upper 12 bits of the register are read/write and correspond to the upper 12 address bits A[31:20] of the 32-bit address. The bottom 4 bits of this register are read-only and return zeros when read. The configuration software must initialize this register. For the purpose of address decode address bits A[19:0] are assumed to be 0. Thus, the bottom of the defined memory address range will be aligned to a 1-MB boundary.

Bit	Description
15:4	Prefetchable Memory Address Base 1 (PMEM_BASE1) . Corresponds to A[31:20] of the memory address.
3:0	Reserved

3.8.20. PMLIMIT1 – Prefetchable Memory Limit Address Register – Device #1

Address Offset: 26-27h
Default Value: 0000h
Access: Read/Write, Read Only
Size: 16 bits

This register controls the host to AGP prefetchable memory accesses routing based on the following formula:

$$\text{PREFETCHABLE_MEMORY_BASE1} = \langle \text{address} \rangle = \langle \text{PREFETCHABLE_MEMORY_LIMIT1} \rangle$$

The upper 12 bits of the register are read/write and correspond to the upper 12 address bits A[31:20] of the 32-bit address. The bottom 4 bits of this register are read-only and return zeroes when read. The configuration software must initialize this register. For the purpose of address decode address bits A[19:0] are assumed to be FFFFh. Thus, the top of the defined memory address range will be at the top of a 1-MB aligned memory block.

Bit	Description
15:4	Prefetchable Memory Address Limit 1 (PMEM_LIMIT1). Corresponds to A[31:20] of the memory address. Default=000h
3:0	Reserved

Note: Prefetchable memory range is supported to allow segregation by the configuration software between the memory ranges that must be defined as UC and the ones that can be designated as a USWC (i.e. prefetchable) from the processor perspective.

3.8.21. BCTRL1 – PCI-PCI Bridge Control Register – Device #1

Address Offset: 3Eh
Default: 00h
Access: Read Only, Read/Write
Size 8 bits

This register provides extensions to the PCICMD1 register that are specific to PCI-PCI bridges. The BCTRL provides additional control for the secondary interface (i.e. AGP) as well as some bits that affect the overall behavior of the “virtual” PCI-PCI bridge embedded within MCH-M, e.g. VGA compatible address ranges mapping.

Bit	Descriptions
7	Fast Back to Back Enable (FB2BEN): Normally this bit controls whether the bridge will generate Fast Back to Back cycles to different targets. However, since there is only one target allowed on the AGP interface, this bit is meaningless. This bit is hardwired to “0”.
6	Secondary Bus Reset (SRESET): MCH-M does not support generation of reset via this bit on the AGP and therefore this bit is hardwired to “0”. Note that the only way to perform a hard reset of the AGP bus is via the system reset either initiated by software or hardware via ICH3-M.
5	Master Abort Mode (MAMODE): This bit is hardwired to “0”. This means when acting as a master on AGP the MCH-M will discard data on writes and return all 1s during reads when a Master Abort occurs.
4	Reserved
3	<p>VGA Enable (VGAEN1): Controls the routing of host initiated transactions targeting VGA compatible I/O and memory address ranges. When this bit is set, the MCH-M will forward the following host-initiated accesses to the AGP bus:</p> <ul style="list-style-type: none"> 1) memory accesses in the range 0A0000h to 0BFFFFh 2) I/O addresses where A[9:0] are in the ranges 3B0h to 3BBh or 3C0h to 3DFh (inclusive of ISA address aliases - A[15:10] are not decoded) <p>When this bit is set, forwarding of these accesses issued by the host is independent of the I/O address and memory address ranges that are defined by the previously defined base and limit registers. Forwarding of these accesses is also independent of the settings of bit 2 (ISA Enable) of this register if this bit is “1”.</p> <p>If this bit is “0” (default), then VGA compatible memory and I/O range accesses are not forwarded to AGP. Instead they are mapped to the hub interface unless they are mapped to AGP via I/O and memory range registers defined above (IOBASE1, IOLIMIT1, MBASE1, MLIMIT1, PMBASE1, PMLIMIT1). Please refer to the System Address Map section of this document for further information.</p>
2	ISA Enable (ISAEN): Modifies the response by the MCH-M to an I/O access issued by the host that targets ISA I/O addresses. This applies only to I/O addresses that are enabled by the IOBASE and IOLIMIT registers. When this bit is set to 1 MCH-M will not forward to AGP any I/O transactions addressing the last 768 bytes in each 1-KB block even if the addresses are within the range defined by the IOBASE and IOLIMIT registers. Instead of going to AGP these cycles will be forwarded to the hub interface. If this bit is “0” (default) then all addresses defined by the IOBASE and IOLIMIT for host I/O transactions will be mapped to AGP.
1	Reserved
0	Parity Error Response Enable (PEREN): Controls MCH-M's response to data phase parity errors on AGP. G_PERR# is not implemented by the MCH-M. However, when this bit is set to 1, address and data parity errors detected on AGP are reported via hub interface SERR# messaging mechanism, if further enabled by SERRE1. If this bit is reset to 0, then address and data parity errors on AGP are not reported via the MCH-M hub interface SERR# messaging mechanism. Other types of error conditions can still be signaled via SERR# messaging independent of this bit's state.

3.8.22. ERRCMD1 – Error Command Register – Device #1

Address Offset: 40h
Default Value: 00h
Access: Read/Write, Read Only
Size: 8 bits

Bit	Description
7:1	Reserved
0	SERR on Receiving Target Abort (SERTA): When this bit is 1 the MCH-M generates an SERR message over hub interface A upon receiving a target abort on AGP. When this bit is set to 0, the MCH-M does not assert an SERR message upon receipt of a target abort on AGP. SERR messaging for Device 1 is globally enabled in the PCICMD1 register.

3.8.23. DWTMC – DRAM Write Thermal Management Control

Offset: 50h-57h
Default: 0000_0000_0000_0000h
Access: Read/Write/Lock
Size: 64 bits

Bit	Description								
63:52	Reserved								
51:50	<p>TM Lock: These bits secure the DRAM Thermal Management control registers. The bits default to '0'. Once a '1' is written to either bit, the configuration register bits specified in DWTMC and DRTMC registers become read-only:</p> <table border="1"> <tr> <td>00</td> <td>Not locked: All bits in DWTMC or DRTMC are writeable.</td> </tr> <tr> <td>01</td> <td>Start Mode bits are not locked: All bits in DWTMC and DRTMC except for SWMT and SRMT are locked and become Read Only.</td> </tr> <tr> <td>10</td> <td>All bits locked: All of the bits in the DWTMC or DRTMC are locked and become Read Only.</td> </tr> <tr> <td>11</td> <td>Reserved</td> </tr> </table>	00	Not locked: All bits in DWTMC or DRTMC are writeable.	01	Start Mode bits are not locked: All bits in DWTMC and DRTMC except for SWMT and SRMT are locked and become Read Only.	10	All bits locked: All of the bits in the DWTMC or DRTMC are locked and become Read Only.	11	Reserved
00	Not locked: All bits in DWTMC or DRTMC are writeable.								
01	Start Mode bits are not locked: All bits in DWTMC and DRTMC except for SWMT and SRMT are locked and become Read Only.								
10	All bits locked: All of the bits in the DWTMC or DRTMC are locked and become Read Only.								
11	Reserved								
49	Reserved								
48:41	Global DRAM Write Sampling Window (GDWSW): This eight bit value is multiplied by 4×10^5 to define the length of time in host clocks over which the number of hexwords(32-Byte chunk) written is counted. If the number of hexwords written during this window exceeds the Global Write Hexword Threshold (GWHT) defined below, then the thermal management mechanism will be invoked.								
40:28	Global Write Hexword Threshold (GWHT): The thirteen-bit value held in this field is multiplied by 2^{15} to arrive at the number of hexwords that must be written within the Global DRAM Write Sampling Window(GDWSW) in order to cause the thermal management mechanism to be invoked.								
27:22	<p>Write Thermal Management Time (WTMT): This value provides a multiplier between 0 and 63, which specifies how long thermal management remains in effect as a number of Global DRAM Write Sampling Windows*. For example, if GDWSW is programmed to 1000_0000b and WTT is set to 01_0000b, then thermal management will be performed for 8192×10^5 host clocks (at 100 MHz) seconds once invoked ($128 * 4 \times 10^5$ host clocks * 16).</p>								
21:15	Write Thermal Management Monitoring Window (WTMMW): The value in this register is padded with 4 0's to specify a window of 0-2047 host clocks with 16 clock granularity. While the thermal management mechanism is invoked, DRAM writes are monitored during this window. If the number of hexwords written during the window reaches the Write Thermal Management Hexword Maximum, then write requests are blocked for the remainder of the window.								
14:3	Write Thermal Management Hexword Maximum (WTMHM): The Write Thermal Management Hexword Maximum defines the maximum number of hexwords between 0-4095, which are permitted to be written to DRAM within one Write Thermal Management Monitoring Window.								

2:1	<p>Write Thermal Management Mode (WTMMode):</p> <table border="1"> <tr> <td data-bbox="513 281 607 352">00</td> <td data-bbox="613 281 1484 352">Thermal management via Counters and Hardware Thermal Management_on signal mechanisms disabled.</td> </tr> <tr> <td data-bbox="513 361 607 529">01</td> <td data-bbox="613 361 1484 529">Hardware Thermal Management_on signal mechanism is enabled. In this mode, as long as the Thermal Management_on signal is asserted, write thermal management is in effect based on the settings in WTMW and WTHM. When the Thermal Management_on signal is de-asserted, write thermal management stops and the counters associated with the WTMW and WTHM are reset. When the hardware Thermal Management_on signal mechanism is not enabled, the Thermal Management_on signal has no effects.</td> </tr> <tr> <td data-bbox="513 537 607 625">10</td> <td data-bbox="613 537 1484 625">Counter mechanism controlled through GDWSW and GWHT is enabled. When the threshold set in GDWSW and GWHT is reached, thermal management start/stop cycles occur based on the settings in WTMT, WTMMW and WTMHM.</td> </tr> <tr> <td data-bbox="513 634 607 667">11</td> <td data-bbox="613 634 1484 667">Reserved</td> </tr> </table>	00	Thermal management via Counters and Hardware Thermal Management_on signal mechanisms disabled.	01	Hardware Thermal Management_on signal mechanism is enabled. In this mode, as long as the Thermal Management_on signal is asserted, write thermal management is in effect based on the settings in WTMW and WTHM. When the Thermal Management_on signal is de-asserted, write thermal management stops and the counters associated with the WTMW and WTHM are reset. When the hardware Thermal Management_on signal mechanism is not enabled, the Thermal Management_on signal has no effects.	10	Counter mechanism controlled through GDWSW and GWHT is enabled. When the threshold set in GDWSW and GWHT is reached, thermal management start/stop cycles occur based on the settings in WTMT, WTMMW and WTMHM.	11	Reserved
00	Thermal management via Counters and Hardware Thermal Management_on signal mechanisms disabled.								
01	Hardware Thermal Management_on signal mechanism is enabled. In this mode, as long as the Thermal Management_on signal is asserted, write thermal management is in effect based on the settings in WTMW and WTHM. When the Thermal Management_on signal is de-asserted, write thermal management stops and the counters associated with the WTMW and WTHM are reset. When the hardware Thermal Management_on signal mechanism is not enabled, the Thermal Management_on signal has no effects.								
10	Counter mechanism controlled through GDWSW and GWHT is enabled. When the threshold set in GDWSW and GWHT is reached, thermal management start/stop cycles occur based on the settings in WTMT, WTMMW and WTMHM.								
11	Reserved								
0	<p>START Write Thermal Management (SWTM): When this bit is set to '1' write thermal management begins based on the settings in WTMW and WTHM, and remains to be in effect until this bit is reset to '0'. When this bit is reset to '0', write thermal management stops and the counters associated with WTMW and WTHM are reset. Software writes to this bit to start and stop write thermal management.</p>								

3.8.24. DRTMC – DRAM Read Thermal Management Control

Offset: 58h-5Fh
Default: 0000_0000_0000_0000h
Access: Read/Write/Lock
Size: 64 bits

Bit	Description								
63:49	Reserved								
48:41	Global DRAM Read Sampling Window (GDRSW): This eight bit value is multiplied by 4×10^5 to define the length of time in host clocks over which the number of hexwords read from the DRAM is counted. If the number of hexwords read during this window exceeds the Global Read Hexword Threshold (GRHT) defined below, then the thermal management mechanism will be invoked.								
40:28	Global Read Hexword Threshold (GRHT): The thirteen-bit value held in this field is multiplied by 2^{15} to arrive at the number of hexwords that must be written within the Global DRAM Read Sampling Window (GDRSW) in order to cause the thermal management mechanism to be invoked.								
27:22	Read Thermal Management Time (RTMT): This value provides a multiplier between 0 and 63 which specifies how long thermal management remains in effect as a number of Global DRAM Read Sampling Windows. For example, if GDRSW is programmed to 1000_0000b and WTT is set to 01_0000b, then thermal management will be performed for 8192×10^5 host clocks (at 100 MHz) seconds once invoked ($128 * 4 \times 10^5$ host clocks * 16).								
21:15	Read Thermal Management Monitoring Window (RTMMW): The value in this register is padded with 4 0's to specify a window of 0-2047 host clocks with 16 clock granularity. While the thermal management mechanism is invoked, DRAM reads are monitored during this window. If the number of hexwords read during the window reaches the Write Thermal Management Hexword Maximum, then read requests are blocked for the remainder of the window.								
14:3	Read Thermal Management Hexword Maximum (RTMHHM): The Read Thermal Management Hexword Maximum defines the maximum number of hexwords between 0-4095, which are permitted to be read to DRAM within one Write Thermal Management Monitoring Window.								
2:1	Read Thermal Management Mode (RTMMode): <table border="1" data-bbox="516 1255 1481 1644"> <tbody> <tr> <td>00</td> <td>Thermal management via Counters and Hardware Thermal Management_on signal mechanisms disabled.</td> </tr> <tr> <td>01</td> <td>Hardware Thermal Management_on signal mechanism is enabled. In this mode, as long as the Thermal Management_on signal is asserted, write thermal management is in effect based on the settings in RTMW and RTHM. When the Thermal Management_on signal is de-asserted, read thermal management stops and the counters associated with the RTMW and RTHM are reset. When the hardware Thermal Management_on signal mechanism is not enabled, the Thermal Management_on signal has no effects.</td> </tr> <tr> <td>10</td> <td>Counter mechanism controlled through GDRSW and GRHT is enabled. When the threshold set in GDRSW and GRHT is reached, thermal management start/stop cycles occur based on the settings in RTMT, RTMMW and RTMHHM.</td> </tr> <tr> <td>11</td> <td>Reserved</td> </tr> </tbody> </table>	00	Thermal management via Counters and Hardware Thermal Management_on signal mechanisms disabled.	01	Hardware Thermal Management_on signal mechanism is enabled. In this mode, as long as the Thermal Management_on signal is asserted, write thermal management is in effect based on the settings in RTMW and RTHM. When the Thermal Management_on signal is de-asserted, read thermal management stops and the counters associated with the RTMW and RTHM are reset. When the hardware Thermal Management_on signal mechanism is not enabled, the Thermal Management_on signal has no effects.	10	Counter mechanism controlled through GDRSW and GRHT is enabled. When the threshold set in GDRSW and GRHT is reached, thermal management start/stop cycles occur based on the settings in RTMT, RTMMW and RTMHHM.	11	Reserved
00	Thermal management via Counters and Hardware Thermal Management_on signal mechanisms disabled.								
01	Hardware Thermal Management_on signal mechanism is enabled. In this mode, as long as the Thermal Management_on signal is asserted, write thermal management is in effect based on the settings in RTMW and RTHM. When the Thermal Management_on signal is de-asserted, read thermal management stops and the counters associated with the RTMW and RTHM are reset. When the hardware Thermal Management_on signal mechanism is not enabled, the Thermal Management_on signal has no effects.								
10	Counter mechanism controlled through GDRSW and GRHT is enabled. When the threshold set in GDRSW and GRHT is reached, thermal management start/stop cycles occur based on the settings in RTMT, RTMMW and RTMHHM.								
11	Reserved								
0	START Read Thermal Management (SRTM): When this bit is set to '1' read thermal management begins based on the settings in RTMW and RTHM, and remains to be in effect until this bit is reset to '0'. When this bit is reset to '0', read thermal management stops and the counters associated with RTMW and RTHM are reset. Software writes to this bit to start and stop read thermal management.								

4. System Address Map

A system based on the Intel 845MP/845MZ Chipset supports 4 GB of addressable memory space and 64 KB+3 of addressable I/O space. The I/O and memory spaces are divided by system configuration software into regions. The memory ranges are useful either as system memory or as specialized memory, while the I/O regions are used solely to control the operation of devices in the system.

4.1. Memory Address Ranges

The system memory map is broken into two categories:

Extended Memory Range (1MB to 4GB) - Extended memory, existing between 1 MB and 4 GB. It contains a 32-bit memory space, which is used for mapping PCI, AGP, APIC, SMRAM, and BIOS memory spaces.

DOS Compatible Area (below 1 MB) - A DOS legacy space, which is used for BIOS and legacy devices on the LPC interface.

Figure 5. Addressable Memory Space

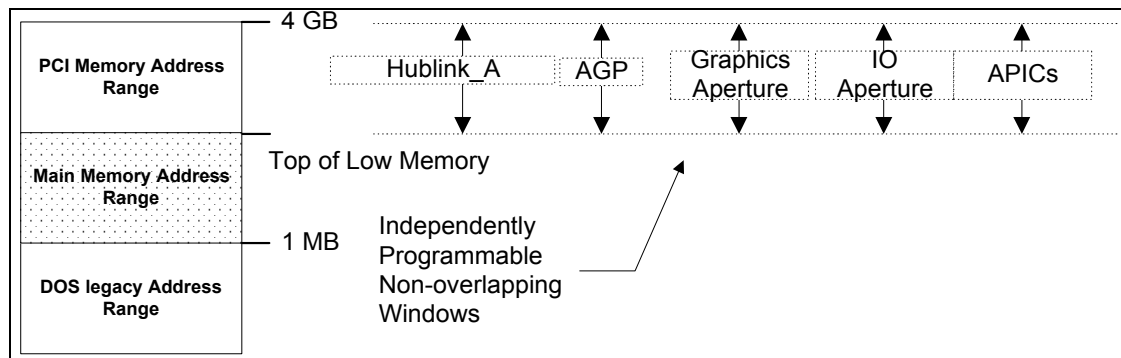

These address ranges are always mapped to system memory, regardless of the system configuration. Memory may be carved out of the MAINMEM segment for use by System Management Mode (SMM) hardware and software. The Top of Low Memory (TOM) register defines the top of Main Memory.

Note: The address of the highest 16-MB quantity of valid memory in the system is placed into the GBA15 register.

For memory populations less than 3 GB, this value will be the same as the one programmed into the TOM register. For other memory configurations, the two are unlikely to be the same, since the PCI configuration portion of the BIOS software will program the TOM register to the maximum value that is less than the amount of memory in the system and that allows enough room for all populated PCI devices.

Figure 6. Detailed DOS Compatible Area Address Map

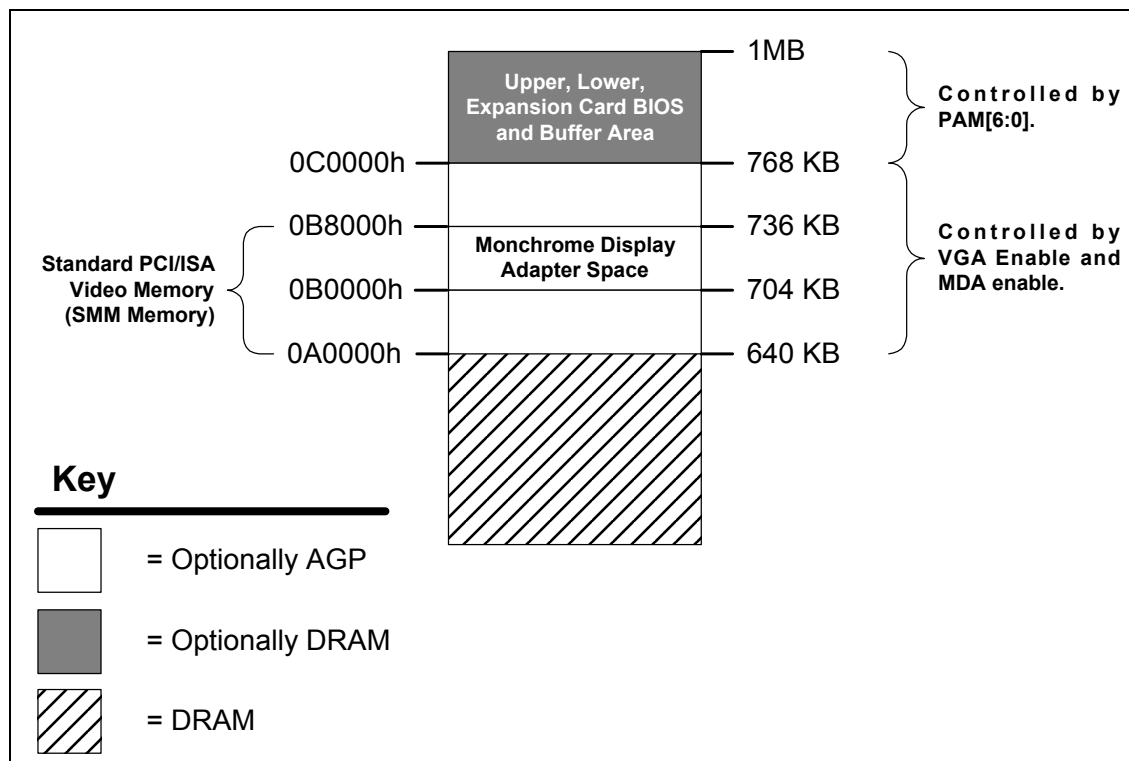

4.1.1. VGA and MDA Memory Space

	From	To	
VGAA	0_000A_0000	0_000A_FFFF	
MDA	0_000B_0000	0_000B_7FFF	
VGAB	0_000B_8000	0_000B_FFFF	

Video cards use the VGAA, MDA, and VGAB legacy address ranges defined above to map a frame buffer or a character-based video buffer. By default, accesses to these ranges are forwarded to hub interface. However, if the VGAEN bit is set in the BCTRL1 configuration register, then transactions within these VGA and MDA memory spaces are sent to AGP instead of the hub interface.

Note: The VGA_EN bit may be set in the BCTRL registers. Software must not set more than one of the VGA_EN bits.

If the configuration bit MCH-MCFG.MDAP is set, then accesses that fall within the MDA range (0B0000h – 0B7FFFh) will be sent to hub interface without regard for the state of the VGAEN bit (but accesses to the VGAA and VGAB ranges will still be sent to AGP). Legacy support requires the ability to have a second graphics controller (monochrome) in the system. In an Intel 845MP/845MZ Chipset system, accesses in the standard VGA range are forwarded to AGP when VGAEN is set. Since the monochrome adapter may be on the hub interface bus (or other expansion bus), the MCH-M must be able to decode cycles in the MDA range and forward them to the hub interface. This capability is controlled by the MDAP configuration bit. In addition to the memory range B0000h to B7FFFh, the MCH-M can decode I/O cycles at 3B4h, 3B5h, 3B8h, 3B9h, 3BAh, and 3BFh and forwards them to hub interface.

4.1.2. PAM Memory Spaces

PAMC0	From	0_000C_0000	To	0_000C_3FFF
PAMC4		0_000C_4000		0_000C_7FFF
PAMC8		0_000C_8000		0_000C_BFFF
PAMCC		0_000C_C000		0_000C_FFFF
PAMD0		0_000D_0000		0_000D_3FFF
PAMD4		0_000D_4000		0_000D_7FFF
PAMD8		0_000D_8000		0_000D_BFFF
PAMDC		0_000D_C000		0_000D_FFFF
PAME0		0_000E_0000		0_000E_3FFF
PAME4		0_000E_4000		0_000E_7FFF
PAME8		0_000E_8000		0_000E_BFFF
PAMEC		0_000E_C000		0_000E_FFFF
PAMF0		0_000F_0000		0_000F_FFFF

The 256-KB PAM region is divided into three parts:

- **ISA expansion region**, a 128-KB area between 0_000C_0000h – 0_000D_FFFFh
- **Extended BIOS region**, a 64-KB area between 0_000E_0000h – 0_000E_FFFFh
- **System BIOS region**, a 64-KB area between 0_000F_0000h – 0_000F_FFFFh.

The ISA expansion region is divided into eight 16 KB segments. Each segment can be assigned one of four Read/Write states: read-only, write-only, read/write, or disabled. Typically, these blocks are mapped through MCH-M and are subtractively decoded to ISA space.

The extended System BIOS region is divided into four 16 Kbytes segments. Each segment can be assigned independent read and write attributes so it can be mapped either to main DRAM or to hub interface. Typically, this area is used for RAM or ROM.

The system BIOS region is a single 64-Kbytes segment. This segment can be assigned read and write attributes. It is by default (after reset) Read/Write disabled and cycles are forwarded to hub interface. By manipulating the read/write attributes, the MCH-M can “shadow” BIOS into main DRAM.

4.1.3. ISA Hole Memory Space

BIOS software may optionally open a “window” between 15 MB and 16 MB (0_00F0_0000h to 0_00FF_FFFF) that relays transactions to hub interface instead of completing them with a system memory access. This window is opened with the FDHC.HEN configuration field.

Figure 7. Detailed Extended Memory Range Address Map

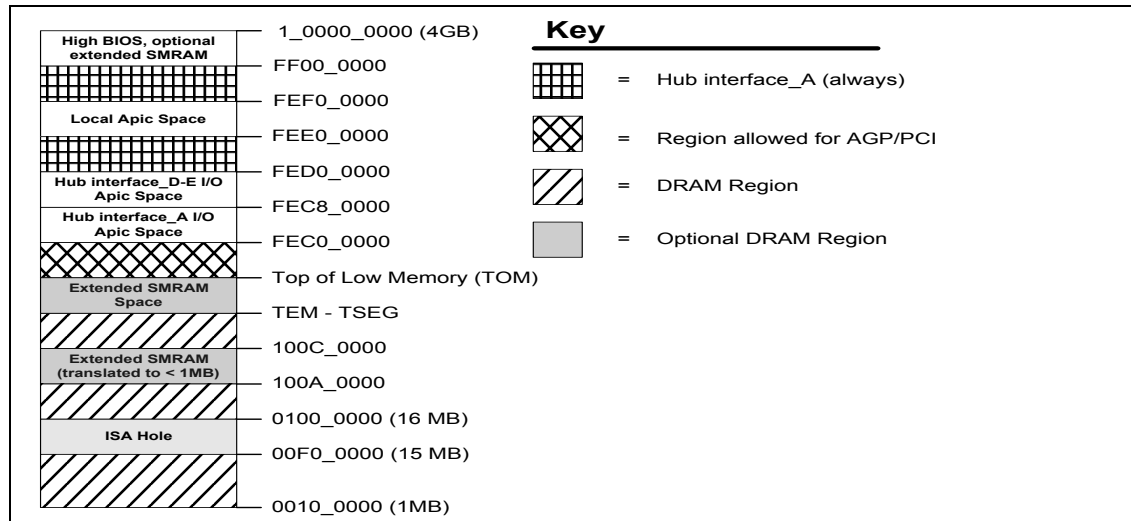

4.1.4. TSEG SMM Memory Space

TSEGSMM	From	TOM – TSEG	To	TOM
---------	------	------------	----	-----

The TSEG SMM space allows system management software to partition a region of main memory just below the top of low memory (TOM) that is accessible only by system management software. This region may be 128 kB, 256 kB, 512 kB, or 1 MB in size, depending upon the ESMRAMC.TSEG_SZ field. SMM memory is globally enabled by SMRAM.G_SMRARE. Requests may access SMM system memory when either SMM space is open (SMRAM.D_OPEN) or the MCH-M receives an SMM code request on its system bus. In order to access the TSEG SMM space, the TSEG must be enabled by ESMRAMC.T_EN. When all of these conditions are met, then a system bus access to the TSEG space (between TOM-TSEG and TOM) is sent to system memory. If the high SMRAM is not enabled or if the TSEG is not enabled, then all memory requests from all interfaces are forwarded to system memory. If the TSEG SMM space is enabled, and an agent attempts a non-SMM access to TSEG space, then the transaction is specially terminated.

Hub interface and AGP originated accesses are not allowed to SMM space.

4.1.5. System Bus Interrupt APIC Memory Space

SBINTR	From	0_FEE0_0000	To	0_FEEF_FFFF
--------	------	-------------	----	-------------

The System Bus interrupt space is the address used to deliver interrupts to the system bus. Any device on AGP or hub interface, D, E may issue a Memory Write to 0FEE_x_xxxxh. The MCH-M will forward this Memory Write along with the data to the system bus as an Interrupt Message Transaction. The MCH-M terminates the system bus transaction by providing the response and asserting TRDY#. This Memory Write cycle does not go to DRAM.

4.1.6. High SMM Memory Space

HIGHSMM	From	0_FEDA_0000	To	0_FEDB_FFFF
---------	------	-------------	----	-------------

The HIGHSMM space allows cacheable access to the compatible SMM space by re-mapping valid SMM accesses between 0_FEDA_0000 and 0_FEDB_FFFF to accesses between 0_000A_0000 and 0_000B_FFFF. The accesses are remapped when SMRAM space is enabled, an appropriate access is detected on the system bus, and when ESMRAMC.H_SMRAME allows access to high SMRAM space. SMM memory accesses from any hub interface or AGP are specially terminated: reads are provided with the value from address 0 while writes are ignored entirely.

4.1.7. AGP Aperture Space (Device #0 BAR)

AGPAPP	From	APBASE	To	APBASE + APSIZE
--------	------	--------	----	-----------------

Processors and AGP devices communicate through a special buffer called the “graphics aperture”. This aperture acts as a window into the main DRAM memory and is defined by the APBASE and APSIZE configuration registers of the Intel 845MP/845MZ Chipset MCH-M. Note that the AGP aperture must be above the top of memory and must not intersect with any other address space.

4.1.8. AGP Memory and Prefetchable Memory

M1	From	MBASE1	To	MLIMIT1
PM1		PMBASE1		PMLIMIT1

Plug-and-play software configures the AGP memory window in order to provide enough memory space for the devices behind this PCI-to-PCI bridge. Accesses whose addresses fall within this window are decoded and forwarded to AGP for completion. Note that these registers must be programmed with values that place the AGP memory space window between the value in the TOM register and 4 GB. In addition, neither region should overlap with any other fixed or relocatable area of memory.

4.1.9. Hub Interface A Subtractive Decode

HLA_SUB	From	TOM	To	4GB
---------	------	-----	----	-----

All accesses that fall between the value programmed into the TOM register and 4GB are subtractively decoded and forwarded to hub interface if they do not decode to a space that corresponds to another device.

4.2. AGP Memory Address Ranges

The MCH-M can be programmed to direct memory accesses to the AGP bus interface when addresses are within either of two ranges specified via registers in MCH-M Device #1 configuration space. The first range is controlled via the Memory Base Register (MBASE1) and Memory Limit Register (MLIMIT1) registers. The second range is controlled via the Prefetchable Memory Base (PMBASE1) and Prefetchable Memory Limit (PMLIMIT1) registers.

The MCH-M positively decodes memory accesses to AGP memory address space as defined by the following equations:

- $\text{Memory_Base_Address} \leq \text{Address} \leq \text{Memory_Limit_Address}$
- $\text{Prefetchable_Memory_Base_Address} \leq \text{Address} \leq \text{Prefetchable_Memory_Limit_Address}$

Plug-and-play configuration software programs the effective size of the range, which depends on the size of memory claimed by the AGP device.

Note: The MCH-M Device #1 memory range registers described above are used to allocate memory address space for any devices sitting on AGP bus that requires such a window.

4.2.1. AGP DRAM Graphics Aperture

Memory-mapped, graphics data structures can reside in a Graphics Aperture to main DRAM memory. This aperture is an address range defined by the APBASE and APSIZE configuration registers of the MCH-M device #0. The APBASE register follows the standard base address register template as defined by the PCI 2.1 specification. The size of the range claimed by the APBASE is programmed via “back-end” register APSIZE (programmed by the chip-set specific BIOS before plug-and-play session is performed). APSIZE allows the BIOS software to pre-configure the aperture size to be 4 MB, 8 MB, 16 MB, 32 MB, 64 MB, 128 MB or 256 MB. By programming APSIZE to specific size, the corresponding lower bits of APBASE are forced to “0” (behave as hardwired). The default value of APSIZE forces an aperture size of 256 MB. The aperture address range is naturally aligned.

Accesses within the aperture range are forwarded to the main DRAM subsystem. The MCH-M will translate the originally issued addresses via a translation table maintained in main memory. The aperture range should be programmed as non-cacheable in the processor caches.

Note: Plug-and-play software configuration model does not allow overlap of different address ranges. Therefore, the AGP Graphics Aperture and AGP Memory Address Range are independent address ranges that may abut, but cannot overlap one another.

4.3. System Management Mode (SMM) Memory Range

The MCH-M supports the use of main memory as System Management RAM (SMRAM) enabling the use of System Management Mode. The MCH-M supports three SMRAM options: Compatible SMRAM (C_SMRAM), High Segment (HSEG), and Top of Memory Segment (TSEG). System Management RAM (SMRAM) space provides a memory area that is available for the SMI handler's and code and data storage. This memory resource is normally hidden from the system OS so that the processor has immediate access to this memory space upon entry to SMM. MCH-M provides three SMRAM options:

- Below 1 MByte option that supports compatible SMI handlers.
- Above 1 MByte option that allows new SMI handlers to execute with write-back cacheable SMRAM.
- Optional larger write-back cacheable T_SEG area from 128 KB to 1MB in size above 1 MByte that is reserved from the highest area in system DRAM memory. The above 1 MByte solutions require changes to compatible SMRAM handlers' code to properly execute above 1 MByte.

Note: Masters from the hub interface and AGP are not allowed to access the SMM space.

4.3.1. SMM Space Definition

The addressed SMM space and the DRAM SMM space define SMM space. The addressed SMM space is defined as the range of bus addresses used by the processor to access SMM space. DRAM SMM space is defined as the range of physical DRAM memory locations containing the SMM code. SMM space can be accessed at one of three transaction address ranges: Compatible, High and TSEG. The Compatible and TSEG SMM space is not remapped and therefore the addressed and DRAM SMM space is the same address range. Since the High SMM space is remapped the addressed and DRAM SMM space is a different address range. Note that the High DRAM space is the same as the Compatible Transaction Address space. Therefore the table below describes three unique address ranges:

- Compatible Transaction Address (Adr C)
- High Transaction Address (Adr H)
- TSEG Transaction Address (Adr T)

These abbreviations are used later in the table describing SMM Space Transaction Handling.

Table 26. SMM Space

SMM Space Enabled	Transaction Address Space (Adr)	DRAM Space (DRAM)
Compatible©	A0000h to BFFFFh	A0000h to BFFFFh
High (H)	0FEDA0000h to 0FEDBFFFFh	A0000h to BFFFFh
TSEG (T)	(TOM-TSEG_SZ) to TOM	(TOM-TSEG_SZ) to TOM

Note: High SMM: Note that this is different than in previous chipsets. In previous chipsets the High segment was the 384-KB region from A0000h to FFFFFh. However, C0000h to FFFFFh was not practically useful so it is deleted in MCH-M.

TSEG SMM: Note that this is different than in previous chip sets. In previous chip sets the TSEG address space was offset by 256 MB to allow for simpler decoding and the TSEG was remapped to just under the TOM. In the MCH-M 256 MB do not offset the TSEG region and it is not remapped.

4.3.2. SMM Space Restrictions

If any of the following conditions are violated the results of SMM accesses are unpredictable and may cause the system to hang:

1. The Compatible SMM space must not be set-up as cacheable.
2. High or TSEG SMM transaction address space must not overlap address space assigned to system DRAM, the AGP aperture range, or to any “PCI” devices (including hub interface and AGP devices). This is a BIOS responsibility.
3. Both D_OPEN and D_CLOSE must not be set to 1 at the same time.
4. When TSEG SMM space is enabled, the TSEG space must not be reported to the OS as available DRAM. This is a BIOS responsibility.
5. Any address translated through the AGP Aperture GTLB must not target DRAM from 000A0000h to 000FFFFFFh.

4.4. I/O Address Space

The Intel 845MP/845MZ Chipset MCH-M does not support the existence of any other I/O devices beside itself on the system bus. The MCH-M generates either hub interface A or AGP bus cycles for all processor I/O accesses. The MCH-M contains two internal registers in the processor I/O space, Configuration Address Register (CONFIG_ADDRESS) and the Configuration Data Register (CONFIG_DATA). These locations are used to implement configuration space access mechanism and as described in the Configuration Register section.

The processor allows 64K+3 bytes to be addressed within the I/O space. The MCH-M propagates the processor I/O address without any translation on to the destination bus and therefore provides addressability for 64K+3 byte locations. Note that the upper three locations can be accessed only during I/O address wrap-around when signal A16# address signal is asserted. A16# is asserted on the system bus whenever an I/O access is made to 4 bytes from address 0FFFDh, 0FFFEh, or 0FFFFh. A16# is also asserted when an I/O access is made to 2 bytes from address 0FFFFh.

The I/O accesses (other than ones used for configuration space access) are forwarded normally to the hub interface A unless they fall within the AGP I/O address range as defined by the mechanisms explained below. The MCH-M will not post I/O write cycles to IDE.

The MCH-M never responds to I/O or configuration cycles initiated on AGP or any of the hub interfaces. Hub interface transactions requiring completion are terminated with “master abort” completion packets on the hub interfaces. Hub interface write transactions not requiring completion are dropped. AGP/PCI I/O reads are never acknowledged by the MCH-M.

4.5. MCH-M Decode Rules and Cross-Bridge Address Mapping

The address map described above applies globally to accesses arriving on any of the three interfaces i.e. Host bus, the hub interface A or AGP.

4.5.1. Decode Rules for the Hub Interface A

The MCH-M accepts accesses from the hub interface A with the following address ranges:

- All memory read and write accesses to Main DRAM (except SMM space).
- All memory write accesses from the hub interface A to AGP memory range defined by MBASE1, MLIMIT1, PMBASE1, and PMLIMIT1.
- All memory read/write accesses to the Graphics Aperture defined by APBASE and APSIZE.
- Memory writes to VGA range on AGP if enabled.

All memory reads from the hub interface A that are targeted > 4 GB memory range will be terminated with Master Abort completion, and all memory writes (>4 GB) from the hub interface A will be ignored.

4.5.2. AGP Interface Decode Rules

Cycles Initiated Using AGP FRAME# Protocol

The MCH-M does not support any AGP FRAME# access targeting the hub interface A. The MCH-M will claim AGP initiated memory read and write transactions decoded to the main DRAM range or the Graphics Aperture range. All other memory read and write requests will be master-aborted by the AGP initiator as a consequence of MCH-M not responding to a transaction.

The MCH-M forwards AGP/PCI accesses addressed to the DOS Compatibility ranges between 0C0000h-0FFFFFFh to main memory, regardless of the configuration of the Programmable Attributes Map registers (PAM registers). The PAM registers govern the destination of host CPU accesses to the DOS Compatibility ranges but do not similarly affect the destination of AGP/PCI accesses to this range. MCH-M will forward to main memory any AGP/PCI initiated access to the PAM areas. Note that the MCH-M may hang if an AGP originated access occurs to a Read Disabled or Write Disabled PAM segment. Therefore, the following critical restriction is placed on the programming of the PAM regions: at the time that an AGP accesses to a PAM region occurs, the targeted PAM segment must be programmed to be both readable and writable. If an AGP master issues an I/O, PCI Configuration or PCI Special Cycle transaction, the MCH-M will not respond and cycle will result in a master-abort.

Cycles Initiated Using AGP PIPE# or SBA Protocol

All cycles must reference main memory i.e. main DRAM address range (including PAM) or Graphics Aperture range (also physically mapped within DRAM but using different address range). AGP accesses to SMM space are not allowed. AGP protocol cycles that target DRAM are not snooped on the host bus, even if they fall outside of the AGP aperture range.

If a cycle is outside of main memory range then it will terminate as follows:

- Reads: remapped to memory address 0h, data returned from address 0h, and IAAF error bit set in ERRSTS register in device #0
- Writes: dropped “on the floor” i.e. terminated internally without affecting any buffers or main memory

AGP Accesses to MCH-M that Cross Device Boundaries

The MCH-M will disconnect AGP FRAME# transactions on 4KB boundaries.

AGP PIPE# and SBA accesses are limited to 256 bytes and must hit DRAM. Read accesses crossing out of DRAM will return invalid data, and the IAAF Error bit will be set. Write accesses crossing out of DRAM will be discarded, and the IAAF Error bit will be set.

5. Functional Description

5.1. Host Interface Overview

The Intel 845MP/845MZ Chipset MCH-M supports the Mobile Intel Pentium 4 Processor-M at 100-MHz bus frequency; the address signals run at 200 MT/s for a maximum address queue rate of 50M addresses/sec. The data is quad pumped and an entire 64B cache line can be transferred in two bus clocks. At 100-MHz bus frequency, the data signals run at 400 MT/s for a maximum bandwidth of 3.2 GB/s. A 12-deep IOQ is supported by the 845MP/845MZ Chipset.

The Intel 845MP/845MZ Chipset MCH-M supports two outstanding deferred transactions on the system bus. The two transactions must target different IO interfaces as only one deferred transaction can be outstanding to any single IO interface at a time.

5.1.1. Dynamic Bus Inversion

The Intel 845MP/845MZ Chipset MCH-M supports Dynamic Bus Inversion (DBI) when driving, and when receiving data from the Host Bus. DBI limits the number of data signals that are driven to a low voltage on each quad pumped data phase. This decreases the power consumption of the MCH-M. DINV[3:0]# indicates if the corresponding 16 bits of data are inverted on the bus for each quad pumped data phase:

Table 27. Relation of DBI Bits to Data Bits

DINV[3:0]#	Data Bits
DBI0#	HD[15:0]#
DIB1#	HD[31:16]#
DBI2#	HD[47:32]#
DBI3#	HD[63:48]#

Whenever the CPU or the MCH-M drives data, each 16-bit segment is analyzed. If more than 8 of the 16 signals would normally be driven low on the bus the corresponding DBI# signal will be asserted and the data will be inverted prior to being driven on the bus. Whenever the CPU or the MCH-M receives data it monitors DBI[3:0]# to determine if the corresponding data segment should be inverted.

5.1.2. System Bus Interrupt Delivery

The Mobile Intel Pentium 4 Processor-M supports System Bus interrupt delivery, but they do not support the APIC serial bus interrupt delivery mechanism. Interrupt related messages are encoded on the System Bus as “Interrupt Message Transactions”. In an Intel 845MP/845MZ Chipset platform, System Bus interrupts may originate from the processor on the System Bus, or from a downstream device on hub interface, or AGP. In the later case the MCH-M drives the “Interrupt Message Transaction” onto the System Bus.

In an Intel 845MP/845MZ Chipset platform and its interrupts are generated as upstream hub interface Memory Writes. Furthermore, PCI 2.2 defines MSI's (Message Signaled Interrupts) that are also in the form of Memory Writes. A PCI 2.2 device may generate an interrupt as an MSI cycle on its PCI bus. The MSI may be directed directly to the System bus. The target of an MSI is dependent on the address of the interrupt Memory Write. The Intel 845MP/845MZ Chipset MCH-M forwards inbound hub interface and AGP (PCI semantic only) Memory Writes to address 0FEEEx_xxxxh, to the System bus as "Interrupt Message Transactions".

5.1.3. Upstream Interrupt Messages

The MCH-M accepts message based interrupts from AGP (PCI semantics only) or its hub interface and forwards them to the System bus as Interrupt Message Transactions. The interrupt messages presented to the MCH-M are in the form of Memory Writes to address 0FEEEx_xxxxh. At the hub interface or AGP interface the Memory Write interrupt message is treated like any other Memory Write; it is either posted into the inbound data buffer (if space is available) or retried (if data buffer space is not immediately available). Once posted, the Memory Write from AGP or the hub interface, to address 0FEEEx_xxxxh, is decoded as a cycle that needs to be propagated by the MCH-M to the System bus as an Interrupt Message Transaction.

5.2. System Memory Interface

5.2.1. DDR Interface Overview

The Intel 845MP Chipset MCH-M supports DDR at 200 and 266 MHz and includes support for:

- Up to 1 GB of PC2100 DDR
- PC2100, unbuffered, 200-pin DDR SO-DIMMs
- Maximum of 2 SO-DIMMs, Single-sided and/or Double-sided b
- Configurable optional ECC

The Intel 845MZ Chipset MCH-M supports DDR at 200 MHz and includes support for:

- Up to 512 MB of PC1600 DDR
- PC1600, unbuffered, 200-pin DDR SO-DIMMs
- Maximum of 2 SO-DIMMs, Single-sided and/or Double-sided
- Configurable optional ECC

The 2 bank select lines SBS[1:0] and the 13 Address lines SMA[12:0] allow the Intel 845MP/845MZ MCH-M to support 64 bit wide SO-DIMMs using 64-Mb, 128-Mb, 256-Mb, and 512-Mb DDR technology. While address lines SMA[9:0] determine the starting address for a burst, burst lengths can be 2, 4, or 8. Four chip selects SCS# lines allow a maximum of two rows of single-sided DDR SO-DIMMs and four rows of double-sided DDR SO-DIMMs.

Intel 845MP/845MZ main memory controller targets CAS latencies of 2 and 2.5 for DDR. Intel 845MP/845MZ provides refresh functionality with a programmable rate (normal DDR rate is 1 refresh/15.6 us). For write operations of less than a Qword in size, the MCH-M will perform a byte-wise write.

5.2.2. Memory Organization and Configuration

Refer to Section 1.3.

5.2.2.1. Configuration Mechanism for SO-DIMMs

Detection of the type of DDR installed on the SO-DIMM is supported via Serial Presence Detect mechanism as defined in the JEDEC 200-pin SO-DIMM specification. This uses the SCL, SDA, and SA[2:0] pins on the SO-DIMMs to detect the type and size of the installed SO-DIMMs. No special programmable modes are provided on Intel 845MP/845MZ MCH-M for detecting the size and type of memory installed. Type and size detection must be done via the serial presence detection pins.

5.2.2.1.1. Memory Detection and Initialization

Before any cycles to the memory interface can be supported, the Intel 845MP/845MZ MCH-M DDR registers must be initialized. The Intel 845MP/845MZ MCH-M must be configured for operation with the installed memory types. Detection of memory type and size is done via the System Management Bus (SMB) interface on the ICH3-M. This two-wire bus is used to extract the DDR type and size information from the Serial Presence Detect port on the DDR SO-DIMMs. DDR SO-DIMMs contain a 5 pin Serial Presence Detect interface, including SCL (serial clock), SDA (serial data) and SA[2:0]. Devices on the SMBus bus have a seven-bit address. For the DDR SO-DIMMs, the upper four bits are fixed at 1010. The lower three bits are strapped on the SA[2:0] pins. SCL and SDA are connected directly to the System Management Bus on the ICH3-M. Thus, data is read from the Serial Presence Detect port on the SO-DIMMs via a series of IO cycles to the south bridge. BIOS essentially needs to determine the size and type of memory used for each of the rows of memory in order to properly configure the Intel 845MP/845MZ MCH-M memory interface.

5.2.2.1.2. SMBus Configuration and Access of the Serial Presence Detect Ports

Refer to the *Intel® ICH3-M Datasheet* for more detail.

5.2.2.1.3. Memory Register Programming

This section provides an overview of how the required information for programming the DDR registers is obtained from the Serial Presence Detect ports on the SO-DIMMs. The Serial Presence Detect ports are used to determine Refresh Rate, MA and MD Buffer Strength, Row Type (on a row by row basis), DDR Timings, Row Sizes, and Row Page Sizes. The following table lists a subset of the data available through the onboard Serial Presence Detect ROM on each SO-DIMM.

Table 28. Data Bytes on SO-DIMM Used for Programming DRAM Registers

Byte	Function
2	Memory Type (SDR SDRAM or DDR SDRAM)
3	# of Row Addresses, not counting Bank Addresses
4	# of Column Addresses
5	# of SO-DIMM banks
11	ECC, no ECC
12	Refresh Rate/Type
17	# Banks on each Device

The above table is only a subset of the defined SPD bytes on the SO-DIMMs. These bytes collectively provide enough data for programming the Intel 845MP/845MZ MCH-M SDRAM registers.

5.2.3. DRAM Performance Description

The overall memory performance is controlled by the DRAM timing register, which pipelines depth used in Intel 845MP/845MZ MCH-M, memory speed grade and the type of SDRAM used in the system. Besides this, the exact performance in a system is also dependent on the total memory supported, external buffering and memory array layout. The most important contribution to overall performance by the System Memory controller is to minimize the latency required to initiate and complete requests to memory, and to support the highest possible bandwidth (full streaming, quick turn-arounds). One measure of performance is the total flight time to complete a cache line request. A true discussion of performance really involves the entire chipset, not just the System Memory controller.

5.2.3.1. Data Integrity (ECC)

The Intel 845MP/845MZ MCH-M supports single-bit Error Correcting Code (or Error Checking and Correcting) and multiple-bit EC (Error Checking) on the main memory interface. The Intel 845MP/845MZ MCH-M generates an 8-bit code word for each 64-bit Qword of memory. Intel 845MP/845MZ MCH-M performs two Qword writes at a time so two 8-bit codes are sent with each write. Since the code word covers a full Qword, writes of less than a Qword require a read-merge-write operation. Consider a Dword write to memory. In this case, when in ECC mode, the Intel 845MP/845MZ MCH-M will read the Qword where the addressed Dword will be written, merge in the new Dword, generate a code covering the new Qword and finally write the entire Qword and code back to memory. Any correctable (single-bit) errors detected during the initial Qword read are corrected before merging the new Dword. The Intel 845MP/845MZ MCH-M also supports another data integrity mode, EC (Error Checking) mode. In this mode, the Intel 845MP/845MZ MCH-M generates and stores a code for each Qword of memory. It then checks the code for reads from memory but does not correct any errors that are found. Thus, the read performance hit associated with ECC is not incurred.

5.3. AGP Interface Overview

The Intel 845MP/845MZ Chipset MCH-M supports 1.5 V AGP 1x/2x/4x devices. The AGP signal buffers are 1.5 V drive/receive (buffers are not 3.3-V tolerant). The MCH-M supports 2x/4x source synchronous clocking transfers for read and write data, and sideband addressing. The MCH-M also supports 1x, 2x and 4x clocking for Fast Writes initiated from the MCH-M (on behalf of the processor).

AGP PIPE# or SBA[7:0] protocol transactions to DRAM do not get snooped and are, therefore, not coherent with the processor caches. AGP FRAME# protocol transactions to DRAM are snooped. AGP PIPE# and SBA[7:0] accesses to and from the hub interface are not supported. AGP FRAME# access from an AGP master to the hub interface are also not supported. Only AGP FRAME# memory writes from the hub interface are supported.

5.3.1. AGP Target Operations

The MCH-M supports AGP cycles targeting main memory only. The MCH-M supports interleaved AGP PIPE#] and AGP FRAME# transactions, or AGP SBA[7:0] and AGP FRAME# transactions.

Table 29. AGP Commands Supported by the MCH-M When Acting as an AGP Target

AGP Command	C/BE[3:0]# Encoding	MCH-M Host Bridge	
		Cycle Destination	Response as PCiX Target
Read	0000	Main Memory	Low Priority Read
	0000	The Hub interface	Complete with random data; does not go to the hub interface
Hi-Priority Read	0001	Main Memory	High Priority Read
	0000	The Hub interface	Complete with random data; does not go to the hub interface
Reserved	0010	N/A	No Response
Reserved	0011	N/A	No Response
Write	0100	Main Memory	Low Priority Write
	0100	The Hub interface	Cycle goes to DRAM with BE's inactive; does not go to the hub interface
Hi-Priority Write	0101	Main Memory	High Priority Write
	0101	The Hub interface	Cycle goes to DRAM with BE's inactive; does not go to the hub interface
Reserved	0110	N/A	No Response
Reserved	0111	N/A	No Response
Long Read	1000	Main Memory	Low Priority Read
		The Hub interface	Complete with random data; does not go to the hub interface
Hi-Priority Long Read	1001	Main Memory	High Priority Read
		The Hub interface	Complete with random data; does not go to the hub interface
Flush	1010	MCH-M	Complete with QW of Random Data
Reserved	1011	N/A	No Response
Fence	1100	MCH-M	No Response - Flag inserted in MCH-M request queue
Reserved	1101	N/A	No Response
Reserved	1110	N/A	No Response

AGP Command	C/BE[3:0]# Encoding	MCH-M Host Bridge	
		Cycle Destination	Response as PCIx Target
Reserved	1111	N/A	No Response

NOTE: N/A refers to a function that is not applicable.

As a target of an AGP cycle, the MCH-M supports all memory read and write transactions targeted at main memory (summarized in the table above). The MCH-M supports both normal and high priority read and write requests. The MCH-M does not support AGP cycles to the hub interface. PIPE# and SBA cycles do not require coherency management and all AGP initiator accesses to main memory using AGP PIPE# or SBA protocol are treated as non-snoopable cycles. These accesses are directed to the AGP aperture in main memory that should be programmed as either uncacheable (UC) memory or write combining (WC) in the processor's MTRRs.

5.3.2. AGP Transaction Ordering

The MCH-M observes transaction ordering rules as defined by the *AGP Interface Specification Rev 2.0*.

5.3.3. AGP Signal Levels

The 1x/2x/4x data transfers use 1.5-V signaling levels as described in the AGP 2.0 specification.

5.3.4. 4x AGP Protocol

In addition to the 1x and 2x AGP protocol, the MCH-M supports 4x AGP read and write data transfers and 4x sideband address. The 4x operation is compliant with the AGP 2.0 specification.

The MCH-M indicates that it supports 4x data transfers through RATE[2] (bit 2) of the AGP Status Register. When DATA_RATE[2] of the AGP Command Register is set to 1 during system initialization, the MCH-M performs AGP read/write data transactions using 4x protocol. This bit is not dynamic. Once this bit is set during initialization, the data transfer rate may not be changed.

The 4x data rate transfer provides 1.06 GB/s transfer rates. The control signal protocol for the 4x data transfer protocol is identical to 1x/2x protocol. In 4x mode 16 bytes of data are transferred on every 66-MHz clock edge. The minimum throttleable block size remains four 66-MHz clocks, which means 64 bytes of data are transferred per block. Three additional signal pins are required to implement the 4x data transfer protocol. These signal pins are complementary data transfer strobes for the AD bus (2) and the SBA bus (1).

5.3.5. Fast Writes

MCH-M supports 2x and 4x Fast Writes from the MCH-M to the graphics controller on AGP. Fast Write operation is compliant with the AGP 2.0 specification.

The MCH-M will not generate Fast Back to Back (FB2B) cycles in 1x mode, but will generate FB2B cycles in 2x and 4x Fast Write modes.

To use the Fast Write protocol, the Fast Write Enable configuration bit, AGPCMD[FWEN] (bit 4 of the AGP Command Register), must be set to 1.

Memory writes originating from the host or from the hub interface use the Fast Write protocol when it is both capability enabled and enabled. The data rate used to perform the Fast Writes is dependent on the bits set in the AGP Command Register bits 2:0 (DATA_RATE). If bit 2 of the AGPCMD[DATA_RATE] field is 1, the data transfers occur using 4x strobing. If bit 1 of AGPCMD[DATA_RATE] field is 1, the data transfers occur using 2x strobing. If bit 0 of AGPCMD[DATA_RATE] field is 1, Fast Writes are disabled and data transfers occur using standard PCI protocol. Note that only one of the three DATA_RATE bits may be set by initialization software. This is summarized in the following table.

Table 30. Fast Write Initialization

FWEN	DATA_RATE [2]	DATA_RATE [1]	DATA_RATE [0]	MCH-M =>AGP Master Write Protocol
0	X	x	x	1x
1	0	0	1	1x
1	0	1	0	2x Strobing
1	1	0	0	4x Strobing

5.3.6. AGP FRAME# Transactions on AGP

The MCH-M accepts and generates AGP FRAME# transactions on the AGP bus. The MCH-M guarantees that AGP FRAME# accesses to DRAM are kept coherent with the processor caches by generating snoops to the host bus. LOCK#, SERR#, and PERR# signals are not supported.

5.3.6.1. MCH-M Target and Initiator Operations for AGP FRAME# Transactions

The following table summarizes MCH-M target operation for AGP FRAME# initiators. The only cycles that will be claimed are memory accesses to main memory.

Table 31. PCI Commands Supported by the MCH-M When Acting as a FRAME# Target

PCI Command	C/BE[3:0]# Encoding	MCH-M	
		Cycle Destination	Response as aFRAME# Target
Interrupt Acknowledge	0000	N/A	No Response
Special Cycle	0001	N/A	No Response
I/O Read	0010	N/A	No Response
I/O Write	0011	N/A	No Response
Reserved	0100	N/A	No Response
Reserved	0101	N/A	No Response
Memory Read	0110	Main Memory	Read
	0110	The Hub interface	No Response
Memory Write	0111	Main Memory	Post Data
	0111	The Hub interface	No Response
Reserved	1000	N/A	No Response

PCI Command	C/BE[3:0]# Encoding	MCH-M	
		Cycle Destination	Response as aFRAME# Target
Reserved	1001	N/A	No Response
Configuration Read	1010	N/A	No Response
Configuration Write	1011	N/A	No Response
Memory Read Multiple	1100	Main Memory	Read
	1100	The Hub interface	No Response
Dual Address Cycle	1101	N/A	No Response
Memory Read Line	1110	Main Memory	Read
	1110	The Hub interface	No Response
Memory Write and Invalidate	1111	Main Memory	Post Data
	1111	The Hub interface	No Response

NOTE: N/A refers to a function that is not applicable.

As a **target** of an AGP FRAME# cycle, the MCH-M only supports the following transactions:

- *Memory Read.* Recommended for reads of 32 bytes or less.
- *Memory Read Line, and Memory Read Multiple.* These commands are supported identically by the MCH-M and allow the MCH-M to continuously supply data during MRL and MRM burst. Recommended for reads of more than 32 bytes. The MCH-M does not support reads of the hub interface bus from AGP.
- *Memory Write and Memory Write and Invalidate.* These commands are aliased and processed identically. The MCH-M does not support writes of the hub interface bus from AGP.
- *Other Commands.* Other commands such as I/O R/W and Configuration R/W are not supported by the MCH-M as a target and result in master abort.
- *Exclusive Access.* The MCH-M does not support PCI locked cycles as a target.
- *Fast Back-to-Back Transactions.* MCH-M as a target supports fast back-to-back cycles from an AGP FRAME# initiator.

As an **initiator** of AGP FRAME# cycle, the MCH-M only supports the following transactions:

- *Memory Read and Memory Read Line.* MCH-M uses these commands to support read requests from host to AGP. MCH-M does not support memory reads from the hub interface to AGP.
- *Memory Read Multiple.* This command is not supported by the MCH-M as an AGP FRAME# initiator.
- *Memory Write.* MCH-M initiates AGP FRAME# write cycles on behalf of the host or the hub interface. MCH-M does not issue Memory Write and Invalidate as an initiator. MCH-M does not support write merging or write collapsing. MCH-M allows non-snooperable write transactions from the hub interface to the AGP bus.
- *I/O Read and Write.* I/O reads and writes from the host are sent to the AGP bus if they fall within the I/O base and limit address range for the AGP bus as programmed in the MCH-M's PCI configuration registers. All other host-initiated I/O accesses that do not correspond to this

programmed address range are forwarded to the hub interface. MCH-M does not support I/O accesses from the hub interface to AGP.

- *Exclusive Access.* MCH-M does not issue a locked cycle on the AGP bus on behalf of either the host or the hub interface. The hub interface and host locked transactions to AGP are initiated as unlocked transactions by the MCH-M on the AGP bus.
- *Configuration Read and Write.* Host Configuration cycles to AGP are forwarded as Type 1 Configuration Cycles. MCH-M does not support configuration reads or writes from the hub interface to AGP.
- *Fast Back-to-Back Transactions.* MCH-M as an initiator does not perform fast back-to-back cycles.

MCH-M Retry/Disconnect Conditions

The MCH-M generates retry/disconnect according to the AGP Specification rules when being accessed as a target by the AGP master using a FRAME# protocol cycle.

Delayed Transactions

When an AGP FRAME#-to-DRAM read cycle is retried by the MCH-M, it is processed internally as a Delayed Transaction.

The MCH-M supports the Delayed Transaction mechanism on the AGP target interface for the transactions issued using AGP FRAME# protocol. This mechanism is compatible with the PCI 2.1 Specification. The process of latching all information required to complete the transaction, terminating with Retry, and completing the request without holding the master in wait-states is called a Delayed Transaction. The MCH-M latches the Address and Command when establishing a Delayed Transaction. The MCH-M generates a Delayed Transaction on the AGP only for AGP FRAME# to DRAM read accesses. The MCH-M does not allow more than one Delayed Transaction access from AGP at any time.

5.4. Power and Thermal Management

An Intel 845MP/845MZ Chipset platform is compliant with the following specifications:

- APM Rev 1.2
- ACPI Rev 1.0b
- ACPI Rev 2.0
- PCI Power Management Rev 1.0
- PC'99, Rev 1.0
- PC'99A
- PC'01, Rev 1.0

5.4.1. Various States

Table 32. Power Management State Combinations

Global (G) state	Sleep (S) State	CPU (C) State	CPU Clock (FCLK)	MCH-M Host Clock (DCLK)	System Memory	Processor State
G0	S0	C0	On	On	On	Full On
G0	S0	C1	On	On	On	Auto-Halt
G0	S0	C2	On	On	On	Stop Grant
G0	S0	C3	Off	On	PwrDown Self Refresh	Deep Sleep
G0	S0	C4	Off	On	PwrDown Self Refresh	DeepER Sleep
G1	S1M	N/A	Off	Off	PwrDown Self Refresh	
G1	S3	N/A	Off	Off	PwrDown Self Refresh	
G1	S4	N/A	Off	Off	PwrDown Self Refresh	
G2	S5	N/A	Off	Off	PwrDown Self Refresh	
G3	N/A	N/A	Off	Off	Off	

5.4.2. General Description of Supported CPU States

- C0 (Full On):** This is the only state that runs software. All clocks are running, STPCLK# is deasserted and the processor core is active. The processor can service snoops and maintain cache coherency in this state.
- C1 (Auto Halt):** The first level of power reduction occurs when the processor executes an Auto-Halt instruction. This stops the execution of the instruction stream and reduces the processor's power consumption. The processor can service snoops and maintain cache coherency in this state.
- C2 (Stop Grant):** To enter this low power state, STPCLK# is asserted. The processor can still service snoops and maintain cache coherency in this state.
- C3 (Sleep or Deep Sleep):** In these states the processor clock is stopped. The MCH-M assumes that no AGP, AGP/PCI, or HubLink cycles (except special cycles) will occur while the MCH-M is in this state. The processor cannot snoop its caches to maintain coherency while in the C3 state.
- C4 (DeepER Sleep):** The C4 state appears to Intel 845MP/845MZ as identical to the C3 state, but in this state the processor core voltage is lowered. There are no internal events in Intel 845MP/845MZ for the C4 state that differ from the C3 state.

5.4.3. General Description of ACPI System States

- **S0 (Awake):** In this state all power planes are active.
- **S1-M (Powered on Suspend for Mobile Systems):** Power is maintained to the CPU and all system components, but most clocks are stopped by the clock synthesizer.
- **S2:** ACPI S2 state is not supported in the Intel 845MP/845MZ Chipset platform.
- **S3 (Suspend To RAM):** The next level of power reduction occurs when the clock synthesizer and core well power planes for the processor and chipset are shut down, but the main memory power plane and the ICH3-M resume well remain active. This is the Suspend To RAM (STR) state. All clocks from synthesizers are shut down during the S3 state.
- **S4 (Suspend to Disk) and S5 (Soft Off):** In these states the main memory power plane is shut down in addition to the clock synthesizer and core well power planes for the processor and chipset. The ICH3-M resume well is still powered.
- **G3 (Mechanical Off):** In this state only the RTC (Real Time Clock) well is powered. The system can only be reactivated via the power switch.

5.4.4. Power Transitions

Table 33. Intel 845MP/845MZ Power Transitions

ACPI State/Feature	C0	C1	C2/S1D	C3/C4	S1M
DDR	Active/Standby & Nap	Active/Standby & Nap	Nap, Active, & Standby	Power-down	Power-down
RAC	Active	Active	Active	Power-down	Power-down
DRCG	Running	Running	Running	Clock Stop Mode	Power-down
Clock Gating	Yes (during writes)	Yes (during writes)	Yes (enabled during snoops)	Yes	Yes
GTL Control Buffer Sense Amp Disable	No	No	No	Yes	Yes
Hublink Interface	Active	Active	Active	Active	Power-down REQ1
CPU PLL	Running	Running	Running	Running	Running
AGP/Hublink PLL	Running	Running	Running	Running	Running
Intel SpeedStep Technology Transition	No	No	No	No	No
Dynamic RAC Power Reduction	Enabled	Enabled	Enabled	Enabled	Enabled

5.4.5. Intel SpeedStep® Technology

Intel SpeedStep® technology allows the system to operate in multiple performance states. Intel SpeedStep technology offers two CPU/system operational modes:

Maximum Performance Mode: Maximum CPU Core Frequency.

Battery Optimized Mode: Reduced CPU core frequency to extend battery life.

Intel SpeedStep technology transitions states only when AC power is connected or disconnected. It transitions by changing the CPU PLL multiplier, which can only be done in the Deep Sleep CPU state (clock going to the CPU is stopped), which is the C3 CPU power state.

Most of the control for Intel SpeedStep technology is done in the ICH3-M. However, the MCH-M must cooperate on certain functions.

5.5. MCH-M Clocking

The CK408 compliant clock synthesizer supports the Intel 845MP/845MZ Chipset. For details refer to the *Intel® Pentium® 4 Processor in the 478 Pin Package* and *Intel® 845MP/845MZ Chipset Platform Design Guide*.

5.6. MCH-M System Reset and Power Sequencing

Please refer to the *Intel® Pentium® 4 Processor in the 478 Pin Package* and *Intel® 845MP/845MZ Chipset Platform Design Guide* for details.

6. Electrical Characteristics

This chapter contains the absolute maximum operating ratings, power characteristics, and DC characteristics for the 845MP/845MZ MCH-M.

6.1. Absolute Maximum Ratings

Table 34 lists the Intel 845MP/845MZ Chipset MCH-M maximum environmental stress ratings. Functional operation at the absolute maximum and minimum is neither implied nor guaranteed. Functional operating parameters are listed in the AC and DC tables.

Warning: Stressing the device beyond the “Absolute Maximum Ratings” may cause permanent damage. These are stress ratings only. Operating beyond the “operating conditions” is not recommended and extended exposure beyond “operating conditions” may affect reliability.

Table 34. Absolute Maximum Ratings

Symbol	Parameter	Min	Max	Unit	Notes
T _{die}	Die Temperature under Bias (with heatsink)	0	98	°C	
T _{die}	Die Temperature under Bias (without heatsink)	0	104	°C	
T _{storage}	Storage Temperature	-55	150	°C	
VCC1_5	1.5 V Supply Voltage with respect to Vss	-0.72	2.69	V	
VCC1_8	1.8 V Supply Voltage with respect to Vss	-0.88	2.5	V	
VCCSM	2.5 V DDR Supply Voltage with respect to Vss	-3.60	6.3	V	
VTT	AGTL+ buffer DC input voltage with respect to Vss	-0.55	2.3	V	
V _{IL} , V _{IH} (DDR)	Voltage on 2.5 V DDR tolerant input pins with respect to Vss	-3.60	6.30	V	

6.2. Thermal Characteristics

The Intel 845MP/845MZ Chipset MCH-M is designed for operation at die temperatures between 0°C and 104°C. The thermal resistance of the package is given in Table 35.

Table 35. Intel 845MP/845MZ Chipset MCH-M Package Thermal Resistance

Parameter	Airflow Velocity in Meters/Second	
	0 m/s	1 m/s
Ψ _{jt} (°C/Watt)**	0.5	1.8
Θ _{ja} (°C/Watt)**	20.0	17.3

NOTE: ** Typical value measured in accordance with EIA/JESD 51-2 testing standard.

6.3. Power Characteristics

Table 36. Power Characteristics

Symbol	Parameter	Min	Typ	Max	Unit	Notes
TDP	Thermal Design Power		4.6		W	1
I _{VTT}	Intel 845MP/845MZ Chipset MCH-M VTT supply Current			2.4	A	2
I _{VCC1_5_CORE}	1.5 V Core Supply Current			1.9	A	2,3
I _{VCC1_5_AGP}	1.5 V AGP Supply Current			0.37	A	2,3
I _{VCC1_8}	1.8 V Hub Interface Supply Current			0.20	A	2
I _{VCCSM}	DDR System Memory Interface (2.5 V) Supply Current			1.9	A	2
I _{SUS_VCCSM}	DDR System Memory Interface (2.5 V) Standby Supply Current			25	mA	
I _{SDREF}	DDR System Memory Interface Reference Voltage (1.25 V) Supply Current			10	mA	
I _{SUS_SDREF}	DDR System Memory Interface Reference Voltage (1.25 V) Standby Supply Current			1	mA	
I _{TTRC}	DDR System Memory Interface Resister Compensation Voltage (1.25 V) Supply Current			40	mA	
I _{SUS_TTRC}	DDR System Memory Interface Resister Compensation Voltage (1.25 V) Standby Supply Current			0	mA	

NOTES:

1. This spec is the Thermal Design Power and it is the estimated maximum possible expected power generated in a component by a realistic application. It is based on extrapolations in both hardware and software technology over the life of the component. It does not represent the expected power generated by a power virus. Studies by Intel indicate that no application will cause thermally significant power dissipation exceeding this specification, although it is possible to concoct higher power synthetic workloads that write but never read. Under realistic read/write conditions, this higher power workload can only be transient, and is accounted in the I_{cc} (Max) spec.
2. Pre-silicon specs have a +20% / -10% tolerance.
3. These current levels can happen simultaneously, and can be summed into one supply.

7. Signal Groups

The signal description includes the type of buffer used for the particular signal.

AGTL+ Open Drain AGTL+ interface signal. Refer to the AGTL+ I/O Specification for complete details. The Intel 845MP/845MZ Chipset MCH-M integrates most AGTL+ termination resistors.

AGP AGP interface signals. These signals are compatible with AGP 2.0 1.5 V Signaling Environment DC and AC Specifications. The buffers are not 3.3 V tolerant.

HI CMOS Hub Interface 1.8 V CMOS buffers.

DDR CMOS DDR System memory 2.5 V CMOS buffers.

Table 37. Signal Groups

Signal Group	Signal Type	Signals	Notes
Host Interface Signal Groups			
(a)	AGTL+ I/O	ADS#, BNR#, BR0#,DBSY#, DBI[3:0]#, DRDY#, HA[31:3]#, HADSTB[1:0] #, HD[63:0]#,HDSTBP[3:0]#, HDSTBN[3:0]#, HIT#, HITM#, HREQ[4:0]#	
(b)	AGTL+ Common Clock Output	BPRI#, CPURST#, DEFER#, HTRDY#, RS[2:0]#	
(c)	AGTL+ Common Clock Input	HLOCK#	
(d)	Host Reference Voltages	HVREF, HSWING[1:0]	
AGP Interface Signal Groups			
(e)	AGP I/O	AD_STB0, AD_STB0#, AD_STB1, AD_STB1#, G_FRAME#, G_IRDY#, G_TRDY#, G_STOP#, G_DEVSEL#, G_AD[31:0], G_CBE[3:0]#, G_PAR	
(f)	AGP Input	PIPE#, SBA[7:0], RBF#, WBF#, SB_STB, SB_STB#, G_REQ#	
(g)	AGP Output	ST[2:0], G_GNT#	
(h)	AGP Reference Voltage	AGPREF	
Hub Interface Signal Groups			
(i)	Hub Interface's CMOS I/O	HI_[10:0], HI_STB, HI_STB#	
(j)	Hub Interface Reference Voltage	HI_REF	
DDR Interface Signal Groups			

Signal Group	Signal Type	Signals	Notes
(k)	DDR CMOS I/O	SDQ[63:0], SCB[7:0], SDQS[8:0]	
(l)	DDR CMOS Output	SCS[3:0]#, SMA[12:0], SBS[1:0], SRAS#, SCAS#, SWE#, SCKE[3:0], RCVENOUT#, SCK[5:0]#	
(m)	DDR CMOS Input	RCVENIN#	
(n)	DDR Reference Voltage	SDREF	
Clocks, Reset, and Miscellaneous Signal Groups			
(o)	CMOS Input	TESTIN#	
(p)	CMOS Input	RSTIN#(3.3V)	
(q)	CMOS Clock Input	HCLKINP, HCLKINN	
(v)	CMOS Clock Input	GCLKIN	
I/O Buffer Supply Voltages			
(r)	AGTL+ Termination Voltage	VTT	
(s)	1.5 V Core and AGP Voltage	VCC1_5	
(t)	1.8 V Hub Interface Voltage	VCC1_8	
(u)	2.5 V DDR Supply Voltage	VCCSM	

8. DC Characteristics

Table 38. DC Characteristics

Symbol	Signal Group	Parameter	Min	Nom	Max	Unit	Notes
I/O Buffer Supply Voltage							
VCCSM	(u)	DDR I/O Supply Voltage	2.375	2.5	2.625	V	
VCC1_8	(t)	1.8V I/O Supply Voltage	1.71	1.8	1.89	V	
VCC1_5	(s)	Core and AGP Voltage	1.425	1.5	1.575	V	
VTT	(r)	Host AGTL+ Termination Voltage	N/A	N/A	1.75	V	
VTTactive	(r)	BK-M Active Range	1.0-5%		1.5+5%		
VTTsleep	®	BK-M Inactive Range	0.85-2.5%		1.5+2.5%		
Reference Voltages							
HVREF	(d)	Host Address and Data Reference Voltage	$2/3 \times VTT - 2\%$	$2/3 \times VTT$	$2/3 \times VTT + 2\%$	V	
HSWING	(d)	Host Compensation Reference Voltage	$1/3 \times VTT - 2\%$	$1/3 \times VTT$	$1/3 \times VTT + 2\%$	V	
HIREF	(j)	Hub Interface Reference Voltage	$0.48 \times VCC1_8$	$1/2 \times VCC1_8$	$0.52 \times VCC1_8$	V	
SDREF	(n)	DDR Reference Voltage	$0.48 \times VCCSM$	$1/2 \times VCCSM$	$0.52 \times VCCSM$	V	
AGPREF	(h)	AGP Reference Voltage	$0.48 \times VCC1_5$	$1/2 \times VCC1_5$	$0.52 \times VCC1_5$	V	
Host Interface							
V _{IL_H}	(a,c)	Host AGTL+ Input Low Voltage			$(2/3 \times VTT) - 0.1$	V	
V _{IH_H}	(a,c)	Host AGTL+ Input High Voltage	$(2/3 \times VTT) + 0.1$			V	
V _{OL_H}	(a,b)	Host AGTL+ Output Low Voltage			$(1/3 \times VTT) + 0.1$	V	
V _{OH_H}	(a,b)	Host AGTL+ Output High Voltage	$VTT - 0.1$			V	
I _{OL_H}	(a,b)	Host AGTL+ Output Low Current			$VTT_{max} / 0.75R_{tmin}$	mA	$R_{tmin} = 45\Omega$
I _{LEAK_H}	(a,c)	Host AGTL+ Input Leakage Current			± 15	μA	$V_{OL} < V_{pad} < VTT$
C _{PAD}	(a,c)	Host AGTL+ Input Capacitance		1.0		pF	
DDR Interface							
V _{IL(DC)}	(k,m)	DDR Input Low Voltage			$SDREF - 0.15$	V	

Symbol	Signal Group	Parameter	Min	Nom	Max	Unit	Notes
$V_{IH(DC)}$	(k,m)	DDR Input High Voltage	SDREF + 0.15			V	
$V_{IL(AC)}$	(k,m)	DDR Input Low Voltage			SDREF - 0.31	V	
$V_{IH(AC)}$	(k,m)	DDR Input High Voltage	SDREF + 0.31			V	
DDR Interface cont.							
V_{OL}	(k,l)	DDR Output Low Voltage			0.975	V	
V_{OH}	(k,l)	DDR Output High Voltage	1.80			V	
I_{OL}	(k,l)	DDR Output Low Current			9.375	mA	
I_{OH}	(k,l)	DDR Output High Current	-9.375			mA	
I_{Leak}	(k,m)	Input Leakage Current			10	uA	
R_{sus_pullup}	(k,m)	Internal Pull-up to Vccsm in suspend	16			KΩ	2.
$C_{I/O}$	(k, l, m)	DDR Input/Output Pin Capacitance	4.690		5.370	pF	
1.5 V AGP Interface							
V_{IL_A}	(e,f)	AGP Input Low Voltage			$0.4 \times VCC1_5$	V	
V_{IH_A}	(e,f)	AGP Input High Voltage	$0.6 \times VCC1_5$			V	
V_{OL_A}	(e,g)	AGP Output Low Voltage			$0.15 \times VCC1_5$	V	
V_{OH_A}	(e,g)	AGP Output High Voltage	$0.85 \times VCC1_5$			V	
I_{OL_A}	(e,g)	AGP Output Low Current			1	mA	@ V_{OL_A} max
I_{OH_A}	(e,g)	AGP Output High Current	-0.2			mA	@ V_{OH_A} max
I_{LEAK_A}	(e,f)	AGP Input Leakage Current			±15	μA	$0 < V_{in} < VCC1_5$
C_{IN_A}	(e,f)	AGP Input Capacitance	1.32		1.92	pF	
1.8 V Hub Interface							
V_{IL_HI}	(i)	Hub Interface Input Low Voltage			HIREF - 0.15	V	
V_{IH_HI}	(i)	Hub Interface Input High Voltage	HIREF + 0.15			V	
V_{OL_HI}	(i)	Hub Interface Output Low Voltage			$0.1 \times VCC1_8$	V	$I_{OL} = 1$ mA
V_{OH_HI}	(i)	Hub Interface Output High Voltage	$0.9 \times VCC1_8$			V	$I_{OH} = 1$ mA
I_{OL_HI}	(i)	Hub Interface Output Low Current			1	mA	@ V_{OL_HI} max
I_{OH_HI}	(i)	Hub Interface Output High Current	-1			mA	@ V_{OH_HI} max
I_{LEAK_HI}	(i)	Hub Interface Input Leakage Current			-150, +15	μA	$0 < V_{in} < VCC1_8$
C_{IN_HI}	(i)	Hub Interface Input Capacitance	2.58		3.17	pF	

Symbol	Signal Group	Parameter	Min	Nom	Max	Unit	Notes
Miscellaneous Signals							
V _{IL}	(o)	Input Low Voltage			HIREF - 0.15	V	
V _{IH}	(o)	Input High Voltage	HIREF + 0.15			V	
V _{OL}	(o)	Output Low Voltage			0.1 x VCC1_8	V	I _{OL} = 1 mA
V _{OH}	(o)	Output High Voltage	0.9 x VCC1_8			V	I _{OH} = 1 mA
I _{OL}	(o)	Output Low Current			1	mA	@V _{OL_HI} max
I _{OH}	(o)	Output High Current	-1			mA	@V _{OH_HI} max
I _{LEAK}	(o)	Input Leakage Current			-150, +15	μA	0 < V _{in} < VCC1_8
C _{IN}	(o)	Input Capacitance	2.58		3.17	pF	
V _{IL}	(p)	Input Low Voltage			0.8	V	
V _{IH}	(p)	Input High Voltage	2.0			V	
I _{LEAK}	(p)	Input Leakage Current			±100	μA	0 < V _{in} < VCC3_3
C _{IN}	(p)	Input Capacitance	4.690		5.370	pF	
V _{IL}	(q)	Input Low Voltage		0		V	
V _{IH}	(q)	Input High Voltage	0.660	0.710	0.850	V	
V _{CROSS}	(q)	Crossing Voltage	0.45x(V _{IH} - V _{IL})	0.5x(V _{IH} - V _{IL})	0.55x(V _{IH} - V _{IL})	V	
C _{IN}	(q)	Input Capacitance	0.94		1.1	pF	
V _{IL}	(v)	Input Low Voltage			0.8	V	
V _{IH}	(v)	Input High Voltage	2.4			V	
C _{IN}	(v)	Input Capacitance	1.2		1.4	pF	

NOTES:

1. Determined with 0.75x MCH-M DDR buffer strength setting.
2. In suspend, not all non-CKE pins will be pulled up; there will be an indeterminate number that will be pulled low.

9. Ballout and Package Information

9.1. Ballout Diagram

Table 39. Top View (Left Side)

	29	28	27	26	25	24	23	22	21	20	19	18	17	16	15
AJ			VSS		VCC1_5		VTT		VTT		VTT		VSS		VSS
AH		SBA0	SBA1		G_GNT#		VSS		VSS		VSS		HD61#		HD57#
AG	VCC1_5	SBA2	SBA3	ST2	ST0	G_REQ#	VTT	VSS	VTT	VSS	VTT	VSS	HD56#	HD55#	HD54#
AF			SB_STB	SB_STB#	VSS	ST1	VCC1_5	PIPE#	VSS	VTT	VSS	VTT	VSS	HD59#	VSS
AE	VSS	SBA4	SBA5	VCC1_5	SBA7	SBA6	WBF#	RBF#	VTT	VSS	VTT	VSS	CPURST#	HD63#	HD60#
AD			NC	NC	GRCOMP	G_AD31	VCC1_5	VSS	VCC1_5	VTT	VSS	VTT	HD62#	VSS	DBI3#
AC	VCC1_5	AD_STB1#	AD_STB1	VSS	G_AD28	G_AD29	VSS	G_AD30	VSS	VSS	VTT	VSS	HD58#	HDSTBP3#	HDSTBN3#
AB			G_AD20	G_AD22	G_AD19	G_AD27	G_AD24	VSS	VCC1_5	VTT	VSS	VTT	HVREF	VSS	VSS
AA	VSS	G_AD18	G_AD21	VCC1_5	G_AD26	G_AD25	G_CBE3#	VCC1_5	AGPREF						
Y			G_AD16	G_AD17	G_CBE2#	G_FRAME#	G_AD23	VSS							
W	VCC1_5	G_DEVSEL#	G_IRDY#	VSS	G_PAR	G_TRDY#	G_STOP#	VCC1_5							
V			G_AD9	G_AD8	G_CBE0#	G_AD15	G_CBE1#	VSS							
U	VSS	G_AD7	G_AD6	VCC1_5	G_AD14	G_AD13	G_AD11	VCC1_5					VSSA1	VCC1_5	VSS
T			G_AD5	G_AD4	G_AD2	G_AD12	G_AD10	VSS					VCCA1	VSS	VCC1_5
R	VCC1_5	G_AD1	G_AD0	VSS	G_AD3	AD_STB0	AD_STB0#	VCC1_5					VSS	VCC1_5	VSS
P			HLRCOMP	HI_REF	HI_0	HI_1	HI_3	66IN					VCC1_5	VSS	VCC1_5
N	VSS	HI_9	HI_2	VCC1_8	HI_STB	HI_STB#	VCC1_8	VSS					VSS	VCC1_5	VSS
M			HI_8	HI_4	HI_5	HI_10	VSS	VCC1_8							
L	VCC1_8	HI_6	HI_7	VSS	VCC1_8	VSS	VCCSM	VSS							
K			VSS	VCCSM	RSVD	VCCSM	RSVD	VCCSM							
J	VSS	SMRCOMP	RSTIN#	VSS	RSVD	SCK1	RSVD	VSS	SDREF						
H			RSVD	TESTIN#	SDQ4	VCCSM	SCKE2	VCCSM	VSS	VCCSM	VSS	VCCSM	VSS	VCCSM	VSS
G	VCCSM	SDQ0	SDQ5	VSS	SCK#1	SCK#4	SCKE0	SMA12	SMA7	SMA8	SMA4	SMA3	RSVD	RSVD	SCK3
F			SDQ1	SDQS0	SDQ6	VSS	SCKE3	VCCSM	SMA9	VSS	SMA6	VCCSM	SMA1	VSS	SCK#0
E	VSS	SDQ3	SDQ8	VSS	SDQ15	SCK4	SDQ17	SCKE1	SDQ19	SMA11	SDQ29	SMA5	SDQ31	SMA2	SDQS8
D			SDQ13	SDQ14	VCCSM	SDQ16	VCCSM	SDQ22	VSS	SDQ25	VCCSM	SDQ27	VSS	SCB1	VCCSM
C	VCCSM	SDQ2	SDQ9	SDQS1	SDQ11	SDQ20	SDQS2	SDQ18	SDQ24	SDQ28	SDQ26	SDQ30	SCB5	SCB0	SCB6
B		SDQ7	SDQ12		SDQ10		SDQ21		SDQ23		SDQS3		SCB4		SCB2
A			VSS		VCCSM		VSS		VCCSM		VSS		VCCSM		VSS
	29	28	27	26	25	24	23	22	21	20	19	18	17	16	15

Table 40. Top View (Right Side)

15	14	13	12	11	10	9	8	7	6	5	4	3	2	1	
VSS		VSS		VSS		VSS		VSS		VSS		VSS			AJ
HD57#		HD49#		HD44#		DBI2#		HD24#		HD31#		HD25#	HD20#		AH
HD54#	HD52#	HD48#	HD45#	HD42#	HD43#	HD38#	HD27#	HD28#	HD29#	HD16#	DBI1#	HD22#	HD17#	VSS	AG
VSS	HD51#	VSS	HD47#	VSS	HD41#	VSS	HD30#	VSS	HD19#	VSS	HD26#	HD21#			AF
HD60#	HD53#	HD46#	HD40#	HDSTBN2#	HD36#	HD34#	HD18#	HDSTBP1#	HDSTBN1#	HD23#	VSS	HD8#	HD15#	VSS	AE
DBI3#	VSS	HSWNG1	VSS	HDSTBP2#	VSS	HD37#	VSS	HD10#	VSS	DBI0#	HDSTBN0#	HDSTBP0#			AD
HDSTBN3#	HD50#	HRCOMP1	HD33#	HD32#	HD39#	HD35#	HD14#	HD11#	HD12#	HD5#	VSS	HD13#	HRCOMP0	VSS	AC
VSS	VSS	VSS	VSS	HVREF	VSS	VSS	VTT	HD9#	VSS	HD1#	HD4#	HD3#			AB
						VTT	VSS	HSWNG0	HD7#	HD2#	VSS	HD6#	HD0#	VSS	AA
							HVREF	BPR1#	VSS	HIT#	DEFER#	HITM#			Y
							VSS	RS1#	RS2#	HLOCK#	VSS	BNR#	RS0#	VSS	W
							VSS	BR0#	VSS	DBSY#	DRDY#	ADS#			V
VSS	VCC1_5	VSSA0					VTT	HTRDY#	HREQ0#	HREQ3#	VSS	HA6#	HREQ4#	VSS	U
VCC1_5	VSS	VCCA0					VSS	HREQ1#	VSS	HA4#	HA3#	HA5#			T
VSS	VCC1_5	VSS					HVREF	HREQ2#	HA11#	HADSTB0#	VSS	HA7#	HA9#	VSS	R
VCC1_5	VSS	VCC1_5					VSS	HA8#	VSS	HA12#	HA10#	HA13#			P
VSS	VCC1_5	VSS					VSS	HA15#	HADSTB1#	HA28#	VSS	HA16#	HA14#	VSS	N
							VTT	HVREF	HA30#	HA24#	HA18#	HA19#			M
							VSS	HA31#	VSS	HA21#	VSS	HA20#	HA26#	VSS	L
							BCLK#	VSS	VCCSM	VSS	HA17#	HA22#			K
						SDREF	BCLK	VCCSM	VSS	VCCSM	VSS	HA25#	HA23#	VSS	J
VSS	VCCSM	VSS	VCCSM	VSS	VCCSM	VSS	VCCSM	RSVD	RSVD	SCK5	HA27#	RCVENOUT#			H
SCK3	SCK#3	SBS1	SBS0	SWE#	RSVD	RSVD	SCAS#	SCK#2	SCK2	SDQ63	VCCSM	RCVENIN#	HA29#	VCCSM	G
SCK#0	VCCSM	SMA10	VSS	SRAS#	VCCSM	SCS#2	VSS	SCS#1	VCCSM	SCK#5	SDQ58	SDQ59			F
SDQS8	SCK0	SDQ32	SMA0	SDQ44	SDQ40	SCS#0	SDQ43	SCS#3	SDQ52	SDQ55	VSS	SDQS7	SDQ62	VSS	E
VCCSM	SCB7	VSS	SDQS4	VCCSM	SDQ39	VSS	SDQ42	VCCSM	SDQ49	VSS	SDQ50	SDQ57			D
SCB6	SCB3	SDQ37	SDQ33	SDQ38	SDQ35	SDQ41	SDQS5	SDQ47	SDQ48	SDQS6	SDQ54	SDQ56	SDQ61	VCCSM	C
SCB2		SDQ36		SDQ34		SDQ45		SDQ46		SDQ53		SDQ51	SDQ60		B
VSS		VCCSM		VSS		VCCSM		VSS		VCCSM		VSS			A
15	14	13	12	11	10	9	8	7	6	5	4	3	2	1	

9.2. Ballout Table

Signal Name	Ball #
66IN	P22
AD_STB0	R24
AD_STB0#	R23
AD_STB1	AC27
AD_STB1#	AC28
ADS#	V3
AGPREF	AA21
BCLK#	K8
BCLK	J8
BNR#	W3
BPRI#	Y7
BR0#	V7
CPURST#	AE17
DBSY#	V5
DEFER#	Y4
DBI0#	AD5
DBI1#	AG4
DBI2#	AH9
DBI3#	AD15
DRDY#	V4
G_AD0	R27
G_AD1	R28
G_AD2	T25
G_AD3	R25
G_AD4	T26
G_AD5	T27
G_AD6	U27
G_AD7	U28
G_AD8	V26
G_AD9	V27
G_AD10	T23
G_AD11	U23

Signal Name	Ball #
G_AD12	T24
G_AD13	U24
G_AD14	U25
G_AD15	V24
G_AD16	Y27
G_AD17	Y26
G_AD18	AA28
G_AD19	AB25
G_AD20	AB27
G_AD21	AA27
G_AD22	AB26
G_AD23	Y23
G_AD24	AB23
G_AD25	AA24
G_AD26	AA25
G_AD27	AB24
G_AD28	AC25
G_AD29	AC24
G_AD30	AC22
G_AD31	AD24
G_CBE0#	V25
G_CBE1#	V23
G_CBE2#	Y25
G_CBE3#	AA23
G_DEVSEL#	W28
G_FRAME#	Y24
G_GNT#	AH25
G_IRDY#	W27
G_PAR	W25
G_REQ#	AG24
G_STOP#	W23
G_TRDY#	W24

Signal Name	Ball #
GRCOMP	AD25
HA3#	T4
HA4#	T5
HA5#	T3
HA6#	U3
HA7#	R3
HA8#	P7
HA9#	R2
HA10#	P4
HA11#	R6
HA12#	P5
HA13#	P3
HA14#	N2
HA15#	N7
HA16#	N3
HA17#	K4
HA18#	M4
HA19#	M3
HA20#	L3
HA21#	L5
HA22#	K3
HA23#	J2
HA24#	M5
HA25#	J3
HA26#	L2
HA27#	H4
HA28#	N5
HA29#	G2
HA30#	M6
HA31#	L7
HADSTB0#	R5
HADSTB1#	N6

Signal Name	Ball #
HD0#	AA2
HD1#	AB5
HD2#	AA5
HD3#	AB3
HD4#	AB4
HD5#	AC5
HD6#	AA3
HD7#	AA6
HD8#	AE3
HD9#	AB7
HD10#	AD7
HD11#	AC7
HD12#	AC6
HD13#	AC3
HD14#	AC8
HD15#	AE2
HD16#	AG5
HD17#	AG2
HD18#	AE8
HD19#	AF6
HD20#	AH2
HD21#	AF3
HD22#	AG3
HD23#	AE5
HD24#	AH7
HD25#	AH3
HD26#	AF4
HD27#	AG8
HD28#	AG7
HD29#	AG6
HD30#	AF8
HD31#	AH5
HD32#	AC11
HD33#	AC12
HD34#	AE9
HD35#	AC9

Signal Name	Ball #
HD36#	AE10
HD37#	AD9
HD38#	AG9
HD39#	AC10
HD40#	AE12
HD41#	AF10
HD42#	AG11
HD43#	AG10
HD44#	AH11
HD45#	AG12
HD46#	AE13
HD47#	AF12
HD48#	AG13
HD49#	AH13
HD50#	AC14
HD51#	AF14
HD52#	AG14
HD53#	AE14
HD54#	AG15
HD55#	AG16
HD56#	AG17
HD57#	AH15
HD58#	AC17
HD59#	AF16
HD60#	AE15
HD61#	AH17
HD62#	AD17
HD63#	AE16
HDSTBN0#	AD4
HDSTBP0#	AD3
HDSTBN1#	AE6
HDSTBP1#	AE7
HDSTBN2#	AE11
HDSTBP2#	AD11
HDSTBN3#	AC15
HDSTBP3#	AC16

Signal Name	Ball #
HI_0	P25
HI_1	P24
HI_2	N27
HI_3	P23
HI_4	M26
HI_5	M25
HI_6	L28
HI_7	L27
HI_8	M27
HI_9	N28
HI_10	M24
HI_REF	P26
HI_STB	N25
HI_STB#	N24
HIT#	Y5
HITM#	Y3
HLOCK#	W5
HLRCOMP	P27
HRCOMP0	AC2
HRCOMP1	AC13
HREQ0#	U6
HREQ1#	T7
HREQ2#	R7
HREQ3#	U5
HREQ4#	U2
HSWNG0	AA7
HSWNG1	AD13
HTRDY#	U7
HVREF	M7,R8,Y8,AB11, AB17
NC	AD26,AD27
PIPE#	AF22
RBF#	AE22
RCVENIN#	G3
RCVENOUT#	H3
RS0#	W2
RS1#	W7

Signal Name	Ball #
RS2#	W6
RSTIN#	J27
RSVD	G9,G10,G16,G17,H6,H7,H27J23,J25,K23,K25,E15
SBA0	AH28
SBA1	AH27
SBA2	AG28
SBA3	AG27
SBA4	AE28
SBA5	AE27
SBA6	AE24
SBA7	AE25
SB_STB	AF27
SB_STB#	AF26
SCAS#	G8
SCK0	E14
SCK1	J24
SCK2	G6
SCK3	G15
SCK4	E24
SCK5	H5
SBS0	G12
SBS1	G13
SCK#0	F15
SCK#1	G25
SCK#2	G7
SCK#3	G14
SCK#4	G24
SCK#5	F5
SCKE0	G23
SCKE1	E22
SCKE2	H23
SCKE3	F23
SCS#0	E9
SCS#1	F7
SCS#2	F9

Signal Name	Ball #
SCS#3	E7
SDQ0	G28
SDQ1	F27
SDQ2	C28
SDQ3	E28
SDQ4	H25
SDQ5	G27
SDQ6	F25
SDQ7	B28
SDQ8	E27
SDQ9	C27
SDQ10	B25
SDQ11	C25
SDQ12	B27
SDQ13	D27
SDQ14	D26
SDQ15	E25
SDQ16	D24
SDQ17	E23
SDQ18	C22
SDQ19	E21
SDQ20	C24
SDQ21	B23
SDQ22	D22
SDQ23	B21
SDQ24	C21
SDQ25	D20
SDQ26	C19
SDQ27	D18
SDQ28	C20
SDQ29	E19
SDQ30	C18
SDQ31	E17
SDQ32	E13
SDQ33	C12
SDQ34	B11

Signal Name	Ball #
SDQ35	C10
SDQ36	B13
SDQ37	C13
SDQ38	C11
SDQ39	D10
SDQ40	E10
SDQ41	C9
SDQ42	D8
SDQ43	E8
SDQ44	E11
SDQ45	B9
SDQ46	B7
SDQ47	C7
SDQ48	C6
SDQ49	D6
SDQ50	D4
SDQ51	B3
SDQ52	E6
SDQ53	B5
SDQ54	C4
SDQ55	E5
SDQ56	C3
SDQ57	D3
SDQ58	F4
SDQ59	F3
SDQ60	B2
SDQ61	C2
SDQ62	E2
SDQ63	G5
SCB0	C16
SCB1	D16
SCB2	B15
SCB3	C14
SCB4	B17
SCB5	C17
SCB6	C15

Signal Name	Ball #
SCB7	D14
SDQS0	F26
SDQS1	C26
SDQS2	C23
SDQS3	B19
SDQS4	D12
SDQS5	C8
SDQS6	C5
SDQS7	E3
SDQS8	E15
SDREF	J9,J21
SMA0	E12
SMA1	F17
SMA2	E16
SMA3	G18
SMA4	G19
SMA5	E18
SMA6	F19
SMA7	G21
SMA8	G20
SMA9	F21
SMA10	F13
SMA11	E20
SMA12	G22
SMRCOMP	J28
SRAS#	F11
ST0	AG25
ST1	AF24
ST2	AG26
SWE#	G11
TESTIN#	H26
VCC1_5	R22,R29,U22,U26,W22,W29,AA22,AA26,AB21,AC29,AD21,AD23,AE26,AF23,AG29,AJ25

Signal Name	Ball #
VCC1_5	N14,N16,P13,P15,P17,R14,R16,T15,U14,U16
VCCA1	T17
VCCA0	T13
VCC1_8	L25,L29,M22,N23,N26
VCCSM	A5,A9,A13,A17,A21,A25,C1,C29,D7,D11,D15,D19,D23,D25,F6,F10,F14,F18,F22,G1,G4,G29,H8,H10,H12,H14,H16,H18,H20,H22,H24,J5,J7,K6,K22,K24,K26, L23
VSS	A3,A7,A11,A15,A19,A23,A27,D5,D9,D13,D17,D21,E1,E4,E26,E29,F8,F12,F16,F20,F24,G26,H9,H11,H13,H15,H17,H19,H21,J1,J4,J6,J22,J26,J29,K5,K7,K27,L1,L4,L6,L8,L22,L24,L26,M23,N1,N4,N8,N13,N15,N17,N22,N29,P6,P8,P14,P16,R1,R4,R13,R15,R17,R26,T6,T8,T14,T16,T22,U1,U4,U15,U29,V6,V8,V22,W1,W4,W8,W26,Y6,Y22,AA1,AA4,AA8,AA29,AB6,AB9,AB10,AB12,AB13,AB14,AB15,AB16,AB19,AB22,AC1,AC4,AC18,AC20,AC21,AC23,AC26,AD6,AD8,AD10,AD12,AD14,AD16,AD19,AD22,AE1,AE4,AE18,AE20,AE29,AF5,AF7,AF9,AF11,AF13,AF15,AF17,AF19,AF21,AF25,AG1,AG18,AG20,AG22,AH19,AH21,AH23,AJ3,AJ5,AJ7,AJ9,AJ11,AJ13,AJ15,AJ17, AJ27

Signal Name	Ball #
VSSA1	U17
VSSA0	U13
VTT	M8,U8,AA9,AB8,AB18,AB20,AC19,AD18,AD20,AE19,AE21,AF18,AF20,AG19,AG21,AG23,AJ19,AJ21,AJ23
WBF#	AE23

9.3. Package Mechanical Information

Figure 8. MCH-M BGA Package Dimensions (Top View)

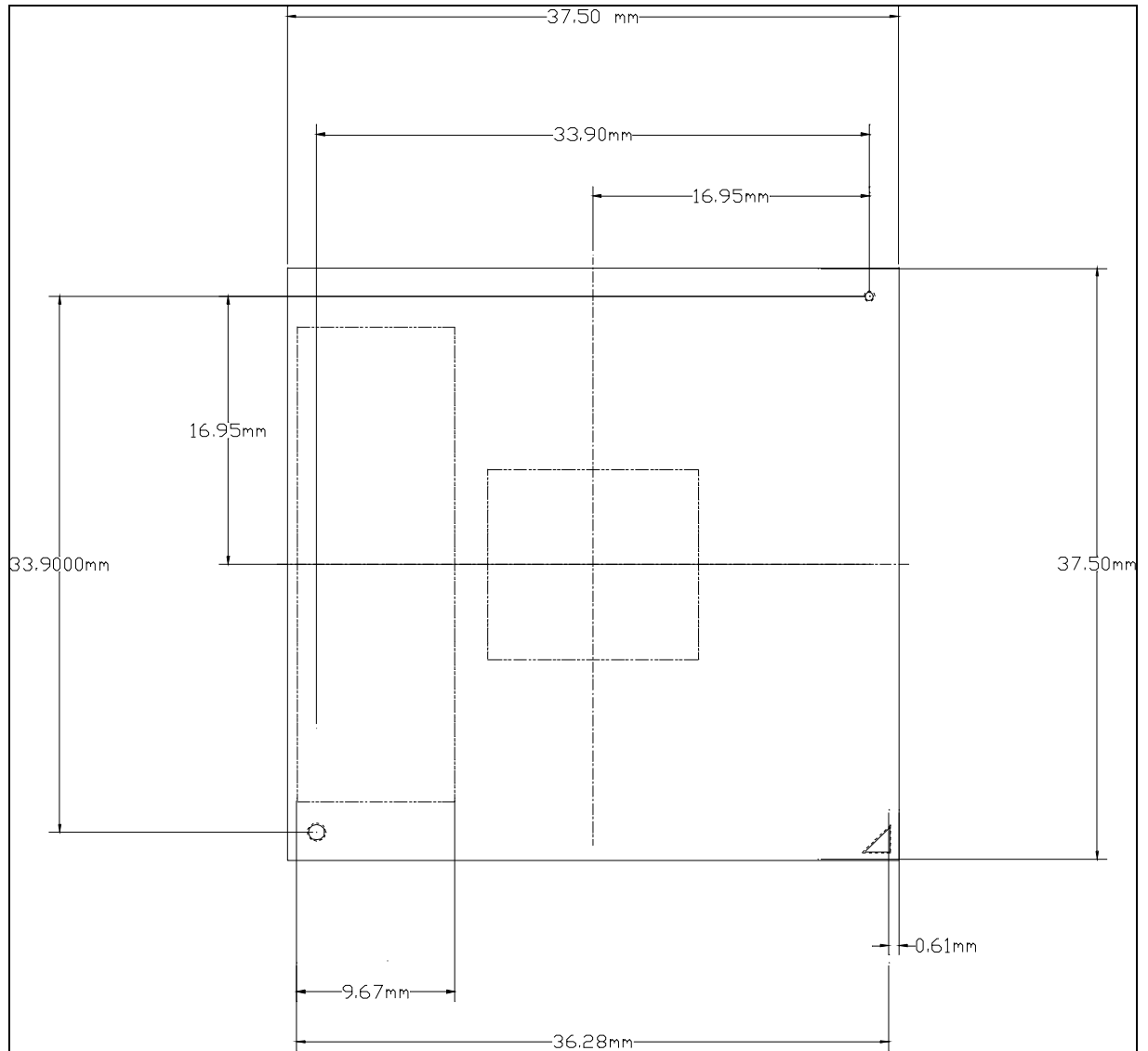

Figure 9. MCH-M BGA Package Dimensions (Side View)

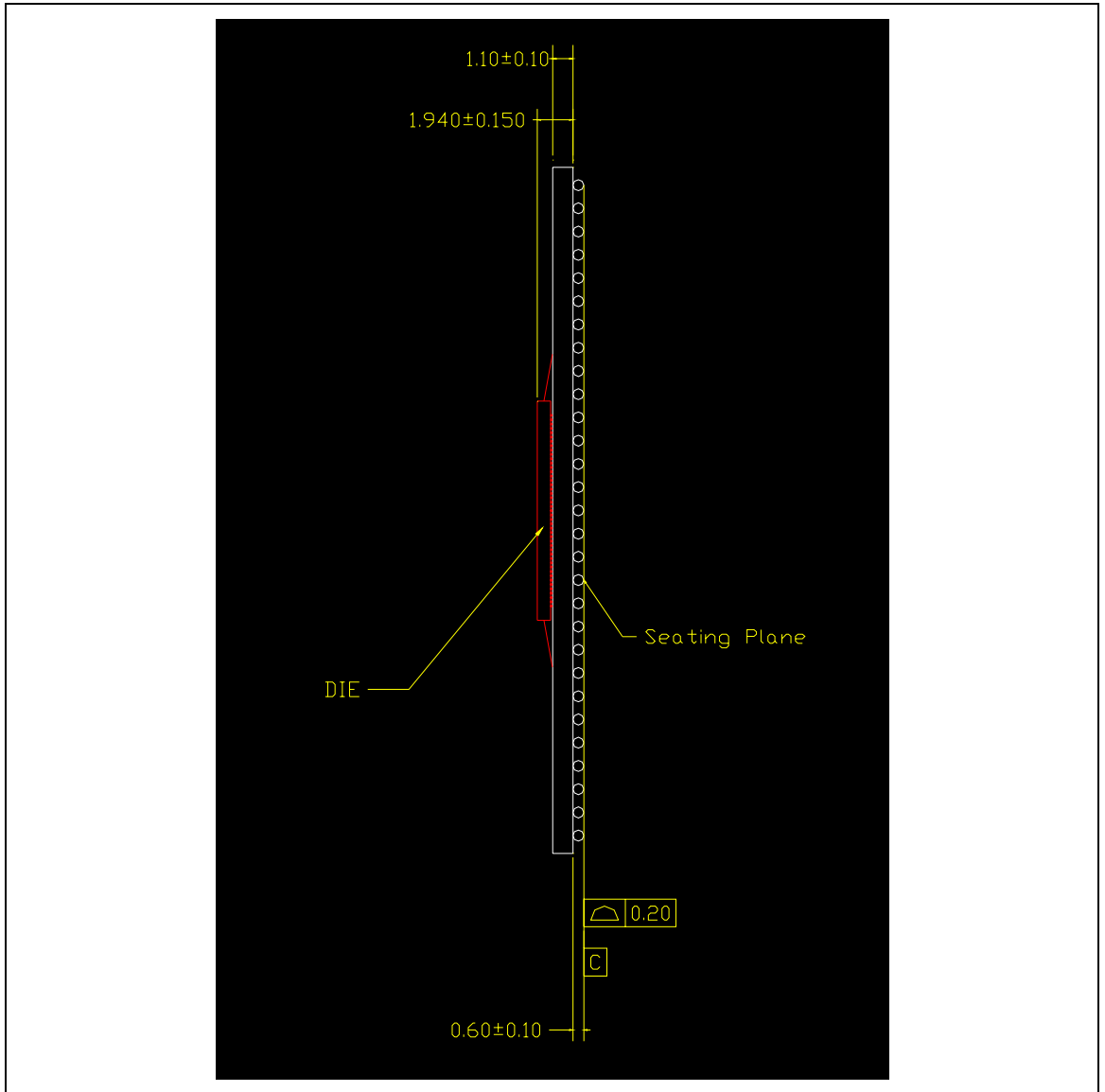

Figure 10. MCH-M BGA Package Dimensions (Bottom View)

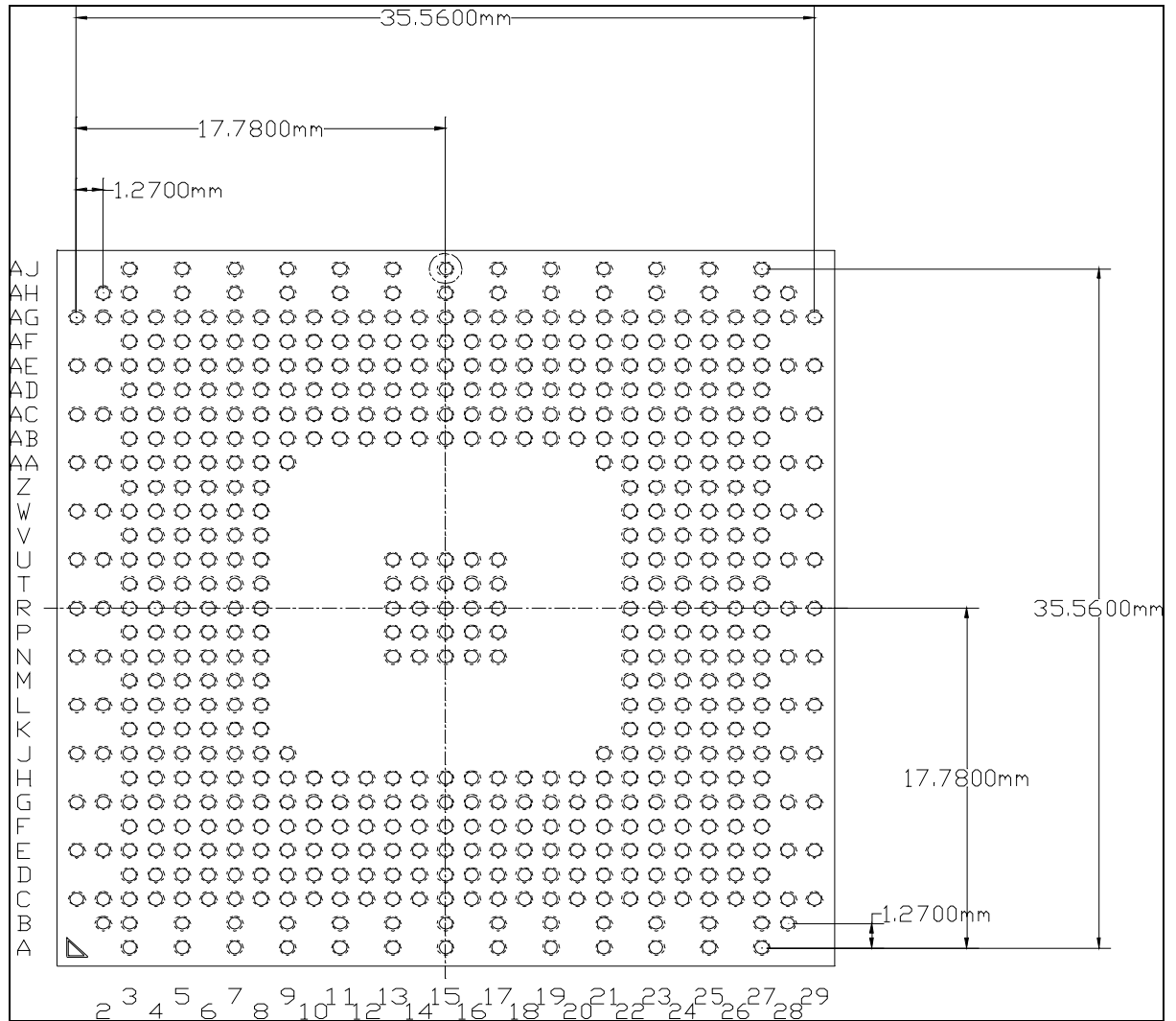

Figure 13. FCBGA Handling Zone Description

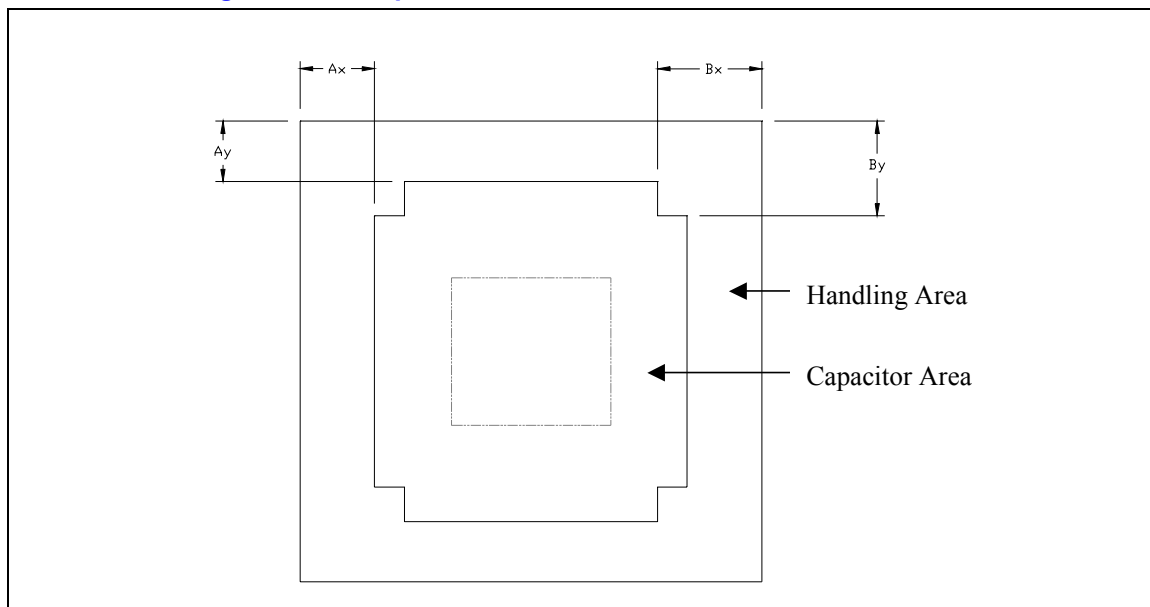

Table 41. FCBGA Handling Zone Description

Handling Zone Description	Value	Label
	37.5 mm x 37.5 mm	
Substrate Edges	7 mm	Ax, Ay
Substrate Corners	8 mm	Bx, By

9.4. Testability

In the MCH-M, testability for Automated Test Equipment (ATE) board level testing has been implemented as an XOR chain. An XOR-tree is a chain of XOR gates, each with one input pin connected to it. Refer to Figure 11 for an example XOR chain.

Figure 11. XOR-Tree Chain

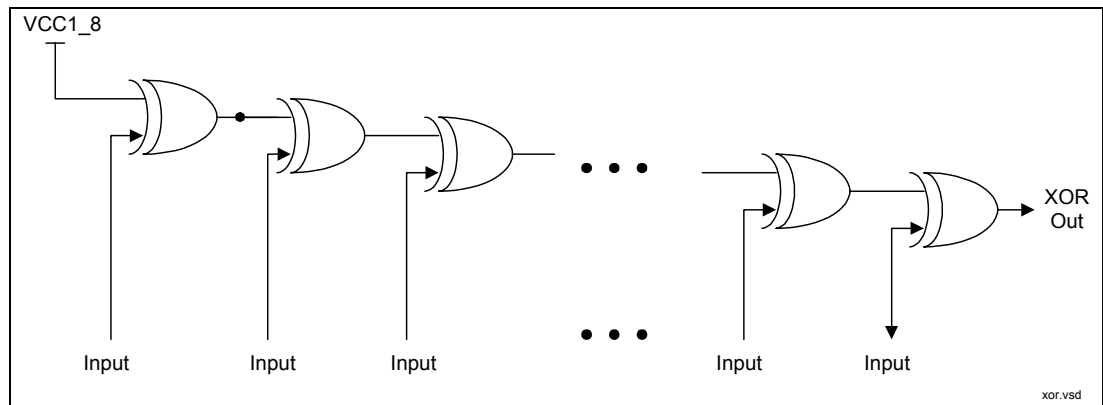

The algorithm used for in-circuit test is as follows

- Drive all input pins to an initial logic level '1'. Observe the output corresponding to scan chain being tested.
- Toggle pins one at a time starting from the first pin in the chain, continuing to the last pin, from its initial logic level to the opposite logic level. Observe the output changes with each pin toggle.

9.4.1. XOR Test Mode Initialization

XOR test mode can be entered by pulling three shared pins (reset straps) low through the rising transition of RSTINB. The signals that need to be pulled are as follows:

GGNTB = 0 (Global strap enable)

SBA[1] = 0 (XOR strap)

ST[2] = 0 (PLL Bypass mode; it is recommended to enter PLL Bypass in XOR test mode)

9.4.2. XOR Chains

Table 42. XOR Chains

Chain 0 Ball	Element #	DDR Signal Name	Note	Initial Logic Level
AE6	1	HDSTBP1#	Input	1
AD3	2	HDSTBP0#	Input	1
V3	3	ADS#	Input	1
U6	4	HREQ0#	Input	1
U3	5	HA6#	Input	1
U2	6	HREQ4#	Input	1
U5	7	HREQ3#	Input	1
T5	8	HA4#	Input	1
T7	9	HREQ1#	Input	1
T4	10	HA3#	Input	1
R7	11	HREQ2#	Input	1
R5	12	HADSTB0#	Input	1
R3	13	HA7#	Input	1
P3	14	HA13#	Input	1
R2	15	HA9#	Input	1
R6	16	HA11#	Input	1
T3	17	HA5#	Input	1
N3	18	HA16#	Input	1
P5	19	HA12#	Input	1
P4	20	HA10#	Input	1
P7	21	HA8#	Input	1
N2	23	HA14#	Input	1
N7	24	HA15#	Input	1
N5	25	HA28#	Input	1
M4	26	HA18#	Input	1
L3	27	HA20#	Input	1
M3	28	HA19#	Input	1
L2	29	HA26#	Input	1
K3	30	HA22#	Input	1
M5	31	HA24#	Input	1
K3	32	HA23#	Input	1
K4	33	HA17#	Input	1
J3	34	HA25#	Input	1

Chain 0 Ball	Element #	DDR Signal Name	Note	Initial Logic Level
L5	35	HA21#	Input	1
H4	36	HA27#	Input	1
M6	37	HA30#	Input	1
L7	38	HA31#	Input	1
G2	39	HA29#	Input	1
H6	40	RSVD	Input	1
H3	41	RCVENOUT#	Input	1
G3	42	RCVENIN#	Input	1
H5	43	SCK5	Input	1
G6	44	SCK2	Input	1
E7	45	SCS#3	Input	1
G8	46	SCAS#	Input	1
G9	47	RSVD	Input	1
AH28	48	SBA0	Output	N/A

Chain 1 Ball	Element #	DDR Ball Name	Note	Initial Logic Level
N6	1	HADSTB1#	Input	1
H7	2	SCK#5	Input	1
G10	3	RSVD	Input	1
G5	4	SDQ63	Input	1
F4	5	SDQ58	Input	1
F3	6	SDQ59	Input	1
C2	7	SDQ61	Input	1
B2	8	SDQ60	Input	1
E2	9	SDQ62	Input	1
D3	10	SDQ57	Input	1
E3	11	SDQS7	Input	1
G7	12	SCK#2	Input	1
C3	13	SDQ56	Input	1
E5	14	SDQ55	Input	1
F7	15	SCS#1	Input	1
D4	16	SDQ50	Input	1
C4	17	SDQ54	Input	1
C5	18	SDQS6	Input	1
E6	19	SDQ52	Input	1
D6	20	SDQ49	Input	1

Chain 1 Ball	Element #	DDR Ball Name	Note	Initial Logic Level
B3	21	SDQ51	Input	1
C6	22	SDQ48	Input	1
B5	23	SDQ53	Input	1
C7	24	SDQ47	Input	1
B7	25	SDQ46	Input	1
E8	26	SDQ43	Input	1
C8	27	SDQ35	Input	1
C9	28	SDQ41	Input	1
D8	29	SDQ42	Input	1
E10	30	SDQ40	Input	1
B9	31	SDQ45	Input	1
E11	32	SDQ44	Input	1
E9	33	SCS#0	Input	1
AH27	34	SBA1	Output	N/A

Chain 2 Ball	Element #	DDR Ball Name	Note	Initial Logic Level
D10	1	SDQ39	Input	1
C10	2	SDQ35	Input	1
C11	3	SDQ38	Input	1
F9	4	SCS#2	Input	1
B11	5	SDQ34	Input	1
B13	6	SDQ36	Input	1
G11	7	SWE#	Input	1
C12	8	SDQ33	Input	1
F11	9	SRAS#	Input	1
C13	10	SDQ37	Input	1
D12	11	SDQS4	Input	1
E12	12	SMA0	Input	1
E13	13	SDQ32	Input	1
G14	14	SCK#3	Input	1
G13	15	SBS1	Input	1
F15	16	SCK#0	Input	1
E15	17	SDQS8	Input	1
G16	18	RSVD	Input	1
E16	19	SMA2	Input	1
E18	20	SMA5	Input	1
F17	21	SMA1	Input	1
F19	22	SMA6	Input	1
G18	23	SMA3	Input	1
G20	24	SMA8	Input	1
G19	25	SMA4	Input	1
F21	26	SMA9	Input	1
G21	27	SMA7	Input	1
E22	28	SCKE1	Input	1
G24	29	SCK#4	Input	1
G23	30	SCKE0	Input	1
G25	31	SCK#1	Input	1
H23	32	SCKE2	Input	1
J25	33	RSVD	Input	1
AG28	34	SBA2	Output	N/A

Chain 3 Ball	Element #	DDR Ball Name	Note	Initial Logic Level
G10	1	RSVD	Input	1
G12	2	SBS0	Input	1
G15	3	SCK3	Input	1
F13	4	SMA10	Input	1
C14	5	SCB3	Input	1
E14	6	SCK0	Input	1
D14	7	SCB7	Input	1
C15	8	SCB6	Input	1
G17	9	RSVD	Input	1
C16	10	SCB0	Input	1
D16	11	SCB1	Input	1
B15	12	SCB2	Input	1
C17	13	SCB5	Input	1
B17	14	SCB4	Input	1
D18	15	SDQ27	Input	1
E17	16	SDQ31	Input	1
B19	17	SDQS3	Input	1
C18	18	SDQ30	Input	1
E19	19	SDQ29	Input	1
C19	20	SDQ26	Input	1
C20	21	SDQ28	Input	1
D20	22	SDQ25	Input	1
C21	23	SDQ24	Input	1
E20	24	SMA11	Input	1
B21	25	SDQ23	Input	1
E21	26	SDQ19	Input	1
C22	27	SDQ18	Input	1
D22	28	SDQ22	Input	1
C24	29	SDQ20	Input	1
C23	30	SDQS2	Input	1
B23	31	SDQ21	Input	1
D24	32	SDQ16	Input	1
G22	33	SMA12	Input	1
E23	34	SDQ17	Input	1
B25	35	SDQ10	Input	1
C25	36	SDQ11	Input	1

Chain 3 Ball	Element #	DDR Ball Name	Note	Initial Logic Level
C27	37	SDQ9	Input	1
D27	38	SDQ13	Input	1
B27	39	SDQ12	Input	1
C26	40	SDQS1	Input	1
F23	41	SCKE3	Input	1
E24	42	SCK4	Input	1
E25	43	SDQ15	Input	1
E27	44	SDQ8	Input	1
N24	45	HL_STB#	Input	1
R24	46	AD_STB0	Input	1
AG27	47	SBA3	Output	N/A

Chain 4 Ball	Element #	DDR Ball Name	Note	Initial Logic Level
D26	1	SDQ14	Input	1
F25	2	SDQ6	Input	1
B28	3	SDQ7	Input	1
C28	4	SDQ2	Input	1
E28	5	SDQ3	Input	1
J24	6	SCK1	Input	1
F26	7	SDQS0	Input	1
H25	8	SDQ4	Input	1
K25	9	RSVD	Input	1
J23	10	RSVD	Input	1
F27	11	SDQ1	Input	1
K23	12	RSVD	Input	1
G28	13	SDQ0	Input	1
G27	14	SDQ5	Input	1
M27	15	RQM	Input	1
M24	16	PSTOP	Input	1
N28	17	RQI	Input	1
L28	18	HL_6	Input	1
M25	19	HL_5	Input	1
N27	20	HL_2	Input	1
M26	21	HL_4	Input	1
N25	22	HL_STB	Input	1
L27	23	HL_7	Input	1
P25	24	HL_0	Input	1
P23	25	HL_3	Input	1
P24	26	HL_1	Input	1
R27	27	G_AD0	Input	1
R28	28	G_AD1	Input	1
U27	29	G_AD6	Input	1
R25	30	G_AD3	Input	1
T27	31	G_AD5	Input	1
T36	32	G_AD4	Input	1
U28	33	G_AD7	Input	1
R24	34	AD_STB0	Input	1
V27	35	G_AD9	Input	1
T25	36	G_AD2	Input	1

Chain 4 Ball	Element #	DDR Ball Name	Note	Initial Logic Level
U27	37	G_AD8	Input	1
T24	38	G_AD12	Input	1
U24	39	G_AD13	Input	1
U25	40	G_AD14	Input	1
T23	41	G_AD10	Input	1
V24	42	G_AD15	Input	1
U23	43	G_AD11	Input	1
AE28	44	SBA4	Output	N/A

Chain 5 Ball	Element #	DDR Ball Name	Note	Initial Logic Level
V25	1	G_CBE0#	Input	1
W28	2	G_DEVSEL#	Input	1
W25	3	G_PAR	Input	1
Y25	4	G_CBE2#	Input	1
W27	5	G_IRDY#	Input	1
V23	6	G_CBE1#	Input	1
Y24	7	G_FRAME#	Input	1
W24	8	G_TRDY#	Input	1
AE23	9	WBF#	Input	1
W23	10	G_STOP#	Input	1
AA23	11	G_CBE3#	Input	1
AA28	12	G_AD18	Input	1
Y26	13	G_AD17	Input	1
Y27	14	G_AD16	Input	1
AB27	15	G_AD20	Input	1
AB26	16	G_AD22	Input	1
AA25	17	G_AD26	Input	1
AA24	18	G_AD25	Input	1
AA27	19	G_AD21	Input	1
AC27	20	AD_STB1	Input	1
Y23	21	G_AD23	Input	1
AC25	22	G_AD28	Input	1
AB25	23	G_AD19	Input	1
AB23	24	G_AD24	Input	1
AB24	25	G_AD31	Input	1
AC24	26	G_AD29	Input	1
AC22	27	G_AD30	Input	1
AB24	28	G_AD27	Input	1
AE22	29	RBF#	Input	1
AF24	30	ST1	Input	1
AF22	31	PIPE#	Input	1
AF27	32	SB_STB	Input	1
AH25	33	G_GNT#	Input	1
AG25	34	ST0	Input	1
AG24	35	G_REQ#	Input	1
AG26	36	ST2	Input	1



Chain 5 Ball	Element #	DDR Ball Name	Note	Initial Logic Level
AH17	37	HD61#	Input	1
AG16	38	HD55#	Input	1
AG17	39	HD56#	Input	1
AC16	40	HDSTBP3#	Input	1
AE11	41	HDSTBP2#	Input	1
AE27	42	SBA5	Output	N/A

Chain 6 Ball	Element #	DDR Ball Name	Note	Initial Logic Level
AC27	1	AD_STB1	Input	1
AF27	2	SB_STB	Input	1
AE17	3	CPURST#	Input	1
AD17	4	HD62#	Input	1
AE16	5	HD63#	Input	1
AH15	6	HD57#	Input	1
AG15	7	HD54#	Input	1
AF16	8	HD59#	Input	1
AC16	9	HDSTBN3#	Input	1
AE15	10	HD60#	Input	1
AG14	11	HD52#	Input	1
AC17	12	HD58#	Input	1
AF14	13	HD51#	Input	1
AE14	14	HD53#	Input	1
AH13	15	HD49#	Input	1
AD15	16	DBI3#	Input	1
AG13	17	HD48#	Input	1
AC14	18	HD50#	Input	1
AF12	19	HD47#	Input	1
AG12	20	HD45#	Input	1
AE12	21	HD40#	Input	1
AE13	22	HD46#	Input	1
AH9	23	DBI2#	Input	1
AG10	24	HD43#	Input	1
AH11	25	HD44#	Input	1
AG9	26	HD38#	Input	1
AG11	27	HD42#	Input	1
AE11	28	HDSTBN2#	Input	1
AF10	29	HD41#	Input	1
AE10	30	HD36#	Input	1
AC12	31	HD33#	Input	1
AC11	32	HD32#	Input	1
AC10	33	HD39#	Input	1
AE9	34	HD34#	Input	1
AC9	35	HD35#	Input	1
AD9	36	HD37#	Input	1

Chain 6 Ball	Element #	DDR Ball Name	Note	Initial Logic Level
AH7	37	HD24#	Input	1
AH5	38	HD31#	Input	1
AG8	39	HD27#	Input	1
Y4	40	DEFER#	Input	1
W7	41	RS1#	Input	1
AE24	42	SBA6	Output	N/A

Chain 7 Ball	Element #	DDR Ball Name	Note	Initial Logic Level
AG6	1	HD29#	Input	1
AG5	2	HD16#	Input	1
AG7	3	HD28#	Input	1
AF6	4	HD19#	Input	1
AF8	5	HD30#	Input	1
AE6	6	HDSTBN1#	Input	1
AG4	7	DBI1#	Input	1
AH3	8	HD25#	Input	1
AE8	9	HD18#	Input	1
AG2	10	HD17#	Input	1
AF4	11	HD26#	Input	1
AH2	12	HD20#	Input	1
AE5	13	HD23#	Input	1
AG3	14	HD22#	Input	1
AF3	15	HD21#	Input	1
AD7	16	HD10#	Input	1
AC7	17	HD11#	Input	1
AC8	18	HD14#	Input	1
AD5	19	DBI0#	Input	1
AC6	20	HD12#	Input	1
AE2	21	HD15#	Input	1
AB7	22	HD9#	Input	1
AE3	23	HD8#	Input	1
AD4	24	HDSTBN0#	Input	1
AC3	25	HD13#	Input	1
AB5	26	HD1#	Input	1
AC5	27	HD5#	Input	1
AA6	28	HD7#	Input	1
AA5	29	HD2#	Input	1
AB3	30	HD3#	Input	1
AA3	31	HD6#	Input	1
AB4	32	HD4#	Input	1
AA2	33	HD0#	Input	1
Y5	34	HIT#	Input	1
Y7	35	BPRI#	Input	1
W6	36	RS2#	Input	1

Chain 7 Ball	Element #	DDR Ball Name	Note	Initial Logic Level
Y3	37	HITM#	Input	1
U7	38	HTRDY#	Input	1
W5	39	HLOCK#	Input	1
V7	40	BR0#	Input	1
W3	41	BNR#	Input	1
W2	41	RS0#	Input	1
V5	43	DBSY#	Input	1
V4	44	DRDY#	Input	1
AE25	45	SBA7	Output	N/A

NOTE: RSTINB, TESTINB, all Rcomp buffers are not part of any XOR chain.