

Mobile Intel® 4 Series Express Chipset Family Graphics Memory Controller Hub (G)MCH

Specification Update

October 2009

Revision 011



INFORMATION IN THIS DOCUMENT IS PROVIDED IN CONNECTION WITH INTEL® PRODUCTS. NO LICENSE, EXPRESS OR IMPLIED, BY ESTOPPEL OR OTHERWISE, TO ANY INTELLECTUAL PROPERTY RIGHTS IS GRANTED BY THIS DOCUMENT. EXCEPT AS PROVIDED IN INTEL'S TERMS AND CONDITIONS OF SALE FOR SUCH PRODUCTS, INTEL ASSUMES NO LIABILITY WHATSOEVER, AND INTEL DISCLAIMS ANY EXPRESS OR IMPLIED WARRANTY, RELATING TO SALE AND/OR USE OF INTEL PRODUCTS INCLUDING LIABILITY OR WARRANTIES RELATING TO FITNESS FOR A PARTICULAR PURPOSE, MERCHANTABILITY, OR INFRINGEMENT OF ANY PATENT, COPYRIGHT OR OTHER INTELLECTUAL PROPERTY RIGHT.

UNLESS OTHERWISE AGREED IN WRITING BY INTEL, THE INTEL PRODUCTS ARE NOT DESIGNED NOR INTENDED FOR ANY APPLICATION IN WHICH THE FAILURE OF THE INTEL PRODUCT COULD CREATE A SITUATION WHERE PERSONAL INJURY OR DEATH MAY OCCUR.

Intel may make changes to specifications and product descriptions at any time, without notice. Designers must not rely on the absence or characteristics of any features or instructions marked "reserved" or "undefined." Intel reserves these for future definition and shall have no responsibility whatsoever for conflicts or incompatibilities arising from future changes to them. The information here is subject to change without notice. Do not finalize a design with this information.

The products described in this document may contain design defects or errors known as errata which may cause the product to deviate from published specifications. Current characterized errata are available on request.

Contact your local Intel sales office or your distributor to obtain the latest specifications and before placing your product order.

This device is protected by U.S. patent numbers 5,315,448 and 6,516,132, and other intellectual property rights. The use of Macrovision's copy protection technology in the device must be authorized by Macrovision and is intended for home and other limited pay-per-view uses only, unless otherwise authorized in writing by Macrovision. Devices incorporating Macrovision's copy protection technology can only be sold or distributed to companies appearing on Macrovision's list of "Authorized Buyers" at: www.macrovision.com. Reverse engineering or disassembly is prohibited.

Intel® Active Management Technology requires the computer system to have an Intel® AMT-enabled chipset, network hardware and software, as well as connection with a power source and a corporate network connection. Setup requires configuration by the purchaser and may require scripting with the management console or further integration into existing security frameworks to enable certain functionality. It may also require modifications of implementation of new business processes. With regard to notebooks, Intel AMT may not be available or certain capabilities may be limited over a host OS-based VPN or when connecting wirelessly, on battery power, sleeping, hibernating or powered off. For more information, see <http://www.intel.com/technology/manage/iamt/>

64-bit computing on Intel architecture requires a computer system with a processor, chipset, BIOS, operating system, device drivers and applications enabled for Intel® 64 architecture. Performance will vary depending on your hardware and software configurations. Consult with your system vendor for more information.

Intel® High Definition Audio requires a system with an appropriate Intel chipset and a motherboard with an appropriate codec and the necessary drivers installed. System sound quality will vary depending on actual implementation, controller, codec, drivers and speakers. For more information about Intel® HD audio, refer to <http://www.intel.com/>

No computer system can provide absolute security under all conditions. Intel® Trusted Execution Technology is a security technology under development by Intel and requires for operation a computer system with Intel® Virtualization Technology, an Intel Trusted Execution Technology-enabled processor, chipset, BIOS, Authenticated Code Modules, and an Intel or other compatible measured virtual machine monitor. In addition, Intel Trusted Execution Technology requires the system to contain a TPMv1.2 as defined by the Trusted Computing Group and specific software for some uses. See <http://www.intel.com/technology/security/> for more information.

Intel® Virtualization Technology requires a computer system with an enabled Intel® processor, BIOS, virtual machine monitor (VMM) and, for some uses, certain computer system software enabled for it. Functionality, performance or other benefits will vary depending on hardware and software configurations and may require a BIOS update. Software applications may not be compatible with all operating systems. Please check with your application vendor.

I²C is a two-wire communications bus/protocol developed by Philips. SMBus is a subset of the I²C bus/protocol and was developed by Intel. Implementations of the I²C bus/protocol may require licenses from various entities, including Philips Electronics N.V. and North American Philips Corporation.

Intel, Celeron, Intel Core, and the Intel logo are trademarks of Intel Corporation in the U.S. and other countries.

*Other names and brands may be claimed as the property of others.

Copyright © 2009, Intel Corporation. All rights reserved.

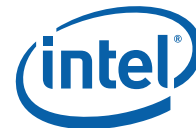

Contents

Revision History	4
Preface	5
Summary Tables of Changes	7
Identification Information	9
Errata	11
Specification Changes	15
Specification Clarifications.....	16
Documentation Changes	17



Revision History

Doc Number	Revision	Description	Date
320123	001	Initial release.	July 2008
320123	002	<ul style="list-style-type: none">Added GL40 and GS45 SKU information	August 2008
320123	003	<ul style="list-style-type: none">Added Errata #4Updated Documentation Changes section	September 2008
320123	004	<ul style="list-style-type: none">Added Errata #5Updated Documentation Changes section	December 2008
320123	005	<ul style="list-style-type: none">Added Errata #6	January 2009
320123	006	<ul style="list-style-type: none">Added the Conversion A1 stepping column in the Summary Table of Changes for Errata listAdded GL40 Conversion A1 Marking Information	March 2009
320123	007	<ul style="list-style-type: none">Added GS45 Package Markings FigureAdded Errata #7 and #8	April 2009
320123	008	<ul style="list-style-type: none">Added GS40 Production Marking Information	June 2009
320123	009	<ul style="list-style-type: none">Added Errata #9 and #10	August 2009
320123	010	<ul style="list-style-type: none">Added Errata #11	September 2009
320123	011	<ul style="list-style-type: none">Updated Intel® GS45 (Low-power) GFX Voltage in Documentation Changes section	October 2009



Preface

This document is an update to the specification contained in the following Affected Documents table. This document is a compilation of device and documentation errata, specification clarifications and changes. It is intended for hardware system manufacturers and software developers or applications, operating systems, or tools.

Information types defined in the Nomenclature section are consolidated into the specification update and are no longer published in other documents.

Related Documents

Document Title	Document Number/Location
<i>Mobile Intel® 4 Series Express Chipset Family Datasheet</i>	320112



Nomenclature

Errata are design defects or errors. Errata may cause the Mobile Intel® 4 Series Chipset family behavior to deviate from published specifications. Hardware and software designed to be used with any given stepping must assume that all errata documented for that stepping are present on all devices.

Specification Changes are modifications to the current published specifications. These changes will be incorporated in the next release of the specifications.

Specification Clarifications describe a specification in greater detail or further highlight a specification's impact to a complex design situation. These clarifications will be incorporated in the next release of the specifications.

Documentation Changes include typos, errors, or omissions from the current published specifications. These changes will be incorporated in the next release of the specifications.

Note: Errata remain in the specification update throughout the product's lifecycle, or until a particular stepping is no longer commercially available. Under these circumstances, errata removed from the specification update are archived and available upon request. Specification changes, specification clarifications and documentation changes are removed from the specification update when the appropriate changes are made to the appropriate product specification or user documentation (datasheets, manuals, etc.).

§



Summary Tables of Changes

The following table indicates the Errata, Specification Changes, Specification Clarifications or Documentation Changes, which apply to the listed (G)MCH steppings. Intel intends to fix some of the errata in a future stepping of the component, and to account for the other outstanding issues through documentation or Specification Changes as noted. This table uses the following notations:

Codes Used in Summary Table

Stepping

X:	Erratum, Specification Change or Clarification that applies to this stepping.
(No mark) or (Blank Box):	This erratum is fixed in listed stepping or specification change does not apply to listed stepping.

Status

Doc:	Document change or update that will be implemented.
Plan Fix:	This erratum may be fixed in a future stepping of the product.
Fixed:	This erratum has been previously fixed.
No Fix:	There are no plans to fix this erratum.

Row

Shaded:	This item is either new or modified from the previous version of the document.
---------	--



Number	Stepping		ERRATA
	B3	A1	
1	X		Mobile Intel® 4 Series Express Chipset Miscorrelation Test Escape
2	X		VTd Function Level Reset (FLR) on Integrated Graphics System Hang
3	X		VTd System Hang on RS2 Exit
4	X		Integrated Audio Codec's Subsystem ID (SSID) Resets to the Default Value after Warm Reset
5	X	X	Mobile Intel® GL40 Express Chipset Audio Corruption
6	X	X	Mobile Intel® 4-Series Express Chipset System Hang on C4 Exit
7	X		Mobile Intel® 4 Series Express Chipset DMA Errors Due to Write-Buffer Flushing Issue
8		X	Mobile Intel® GL40 Express Chipset A1 Conversion Step System Hang on Windows* Idle Errata
9	X	X	Mobile Intel® 4 Series Express Chipset Self-Refresh Exit VIX Spec Violation Issue
10	X	X	Mobile Intel® GM45/GS45 Express Chipset, Intel® Flex Memory Technology & Intel® Virtualization Technology (Intel® VT) for Directed I/O (Intel® VT-d) Compatibility Issue
11	X	X	Mobile Intel® 4 Series Express Chipsets Integrated Graphics Overlay Display Corruption Issue

Number	SPECIFICATION CHANGES
	There are no specification changes in this Specification Update revision.

Number	SPECIFICATION CLARIFICATIONS
	There are no specification clarifications in this Specification Update revision.

Number	DOCUMENTATION CHANGES
	Mobile Intel® 4 Series Express Chipset Family Datasheet Document# 320122 These changes will be included in the next revision of the datasheet.
1	Intel® GS45 (Low-power) GFX Voltage



Identification Information

Component Marking Information

Component identification via marking information and programmed registers is detailed below for the currently available steppings of the Mobile Intel 4 Series Express Chipset family silicon.

Product	QDF/ S-Spec	Stepping	MM#	CRID ¹	SRID ²	Device ID ³	Description
GM45 (Lead Free)	SLB94	B3	898200	0111b	07h	2A40h	Production
PM45 (Lead Free)	SLB97	B3	898203	0111b	07h	2A40h	Production
GS45 (Lead Free)	SLB92	B3	898196	0111b	07h	2A40h	Production
GL40 (Lead Free)	SLB95	B3	898201	0111b	07h	2A40h	Production
GL40 (Lead Free)	SLGGM	A1	900100	0111b	09h	2A40h	Production
GS40 (Lead Free)	SLGT8	B3	902308	0111b	07h	2A40h	Production

NOTES:

1. CRID can be determined by reading bit[61:58] of the register at B/D/F/Type - 0/0/0/PCI Offset 0E0h.
2. SRID can be determined by reading the register at B/D/F/Type - 0/0/0/PCI Offset 08h.
3. DID can be determined by reading the register at B/D/F/Type - 0/0/0/PCI Offset 02h.

Figure 1. Mobile Intel® GM45/PM45/GL40 Express Chipset Family Graphics Memory Controller Hub (G)MCH Lead-Free Package Markings

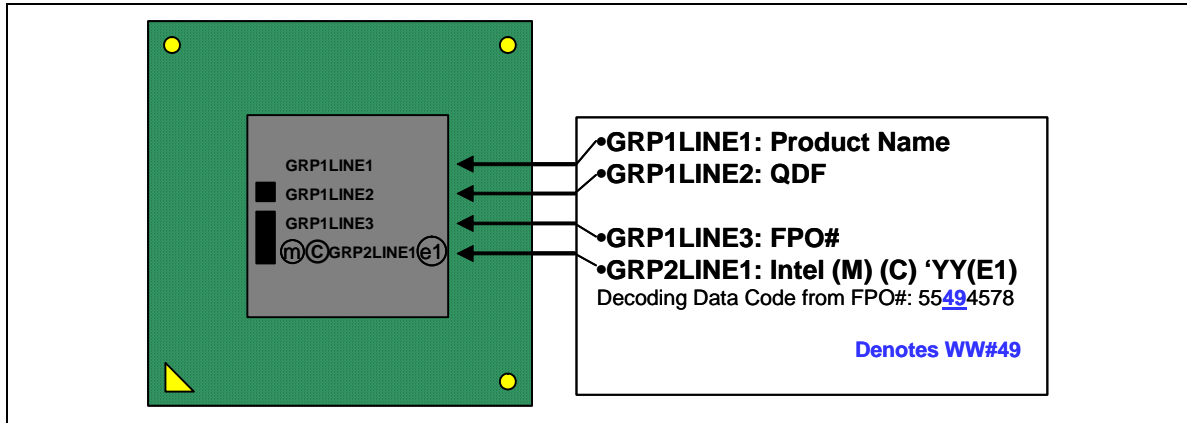
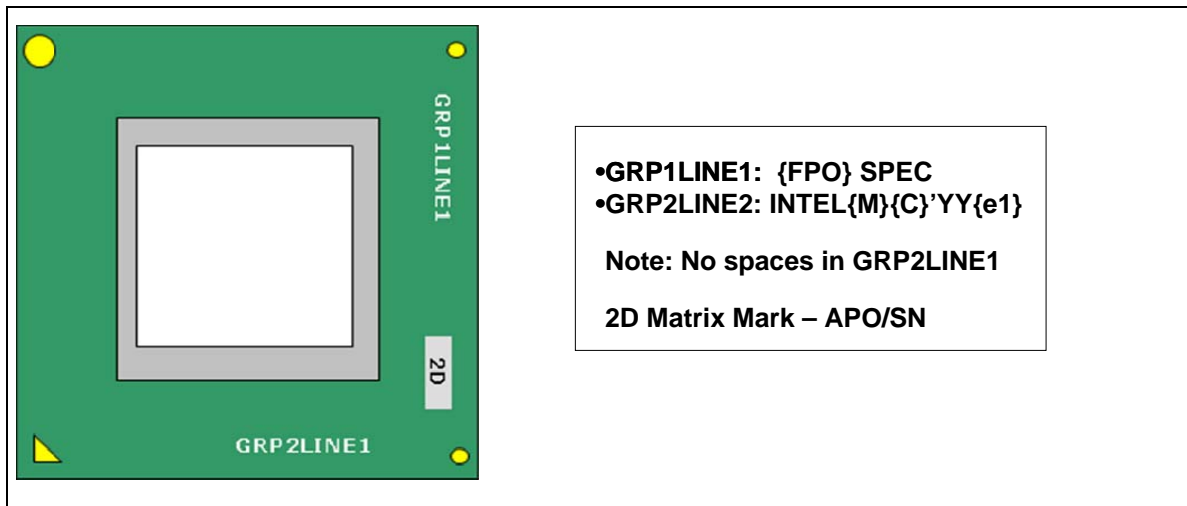

Figure 2. Mobile Intel® GS45/GS40 Express Chipset Graphics Memory Controller Hub (G)MCH Lead-Free Package Markings





Errata

1. Mobile Intel® 4 Series Express Chipset Miscorrelation Test Escape

Problem: VCC_{min} specification violation observed on the Intel® GM45 chipset component during 3D intensive stress testing at extreme conditions (max temp and VCCmin).

Implication: This issue may lead to a system hang.

Workaround: The workaround includes a graphics driver (version 15.9.4 or later [Microsoft Windows Vista*], 14.34.2 or later [Windows XP*]) and BIOS Update.

Status: No Fix.

2. VTd Function Level Reset (FLR) on Integrated Graphics System Hang

Problem: The VTd logic within the Mobile Intel 4 Series Express Chipset may not properly perform a Function Level Reset (FLR) during iGFX decode of AVC or VC-1 bit streams.

Implication: The incorrect reporting under the above conditions may cause a system hang.

Workaround: A software workaround is available through 3rd party VMM suppliers. Contact the VMM vendor for software status.

Status: No Fix.

3. VTd System Hang on RS2 Exit

Problem: Mobile Intel 4 Series Express Chipset systems are unable to exit RS2 due to VTd DMA remap enable requests and graphics IOTLB (IO Translation Lookaside Buffer) invalidation requests.

Implication: Systems attempting to exiting RS2 due to DMA remap enable or graphics IOTBL invalidation request on iGFX VTd systems may experience system hang.

Workaround: A software workaround is available through 3rd party VMM suppliers. Contact the VMM vendor for software status.

Status: No Fix.



4. **Integrated Audio Codec's Subsystem ID (SSID) Resets to the Default Value after Warm Reset**

Problem: Mobile Intel® 4 Series Express Chipset's integrated audio codec's subsystem ID register will reset to the default value of 80860101h after CF9 reset.

Implication: All Intel Series 4 Express Chipsets' integrated HDMI audio codec will have the same SSID value of 80860101h after OS boot, regardless of values programmed by system BIOS.

Workaround: Workaround available in the Intel Installer: The graphics driver and audio driver must be present in the same installer package. The Intel driver installer will look for the integrated graphics' SSID to determine the audio driver's installation. If the integrated graphics' SSID does not match the value in the graphics driver's .INF file the audio driver will not install. The graphics driver's .INF file will contain a unique SSID per customer, but the audio driver's .INF file will contain the default SSID of 80860101h. There is no impact to Microsoft Windows* Update or WHQL testing.

Status: No Fix.

5. **Mobile Intel® GL40 Express Chipset Audio Corruption**

Problem: Audio corruption or loss may occur when applications play media files on systems using the Mobile Intel® GL40 Express Chipset running 64-bit OS with 4-GB system memory.

Implication: Audio corruption or loss may occur while playing media applications.

This issue has only been observed on systems using Mobile Intel® GL40 Express Chipset running Microsoft Windows Vista* (64-bit) Service Pack 1 with 4-GB system memory.

Workaround: BIOS workaround is available.

Status: No Fix.

6. **Mobile Intel® 4-Series Express Chipset System Hang on C4 Exit**

Problem: Mobile Intel® 4-Series Express Chipset Platform may not exit C4 or C6 for break events to C2.

Implication: This issue may lead to a system hang.

Workaround: BIOS workaround is available.

Status: No Fix.



7. Mobile Intel® 4 Series Express Chipset DMA Errors Due to Write-Buffer Flushing Issue

Problem: The “Required Write Buffer Flush” (*RWBF - Bit 4*) field of the VT-d Capability Register (*Register Offset 0x8* in the 4 KB memory-mapped IO register space for VT-d DMA remapping engine) for some DMA remap engines is incorrectly reporting value of ‘0’ (i.e. “Write Buffer Flushing” NOT required). The correct value for RWBF field for all VT-d engines should be ‘1’ (i.e. “Write Buffer Flushing” is required).

This issue is specific to Mobile Intel® GM45/PM45/GS45 Express Chipsets.

Implication: As hardware reports RWBF field as ‘0’, software may skip explicit write-buffer flushing. This can lead to remapping hardware fetching stale VT-d translation entries, causing subsequent DMA transactions to result in DMA remapping faults.

Workaround: Due to this erratum, VT-d enabled system software (VMM/OS) is required to function as if the RWBF bit has a value of ‘1’ (i.e., explicitly flush write-buffers as specified by the VT-d architecture specification).

Status: No Fix.

8. Mobile Intel® GL40 Express Chipset A1 Conversion Step System Hang on Windows* Idle Errata

Problem: Systems using Mobile Intel® GL40 Express Chipset A1 Conversion Step may not exit C2 for break events to C0.

Implication: This issue may lead to a system hang.

Workaround: BIOS workaround is available.

Status: No fix.

9. Mobile Intel® 4 Series Express Chipsets Self-Refresh Exit VIX Spec Violation Issue

Problem: The Mobile Intel® 4 Series Express Chipset family may not comply with the JEDEC* Spec for VIX min voltage specified for clock signal (CK) when exiting DDR3 dynamic self-refresh (SRX)

Implication: This may result in indeterminate system behavior

Intel has not observed any functional failures resulting from this issue in laboratory testing in synthetic test environments with focused test patterns.

Workaround: None. A MRC change has been made in revision 2.9 to significantly reduce exposure to this issue. For systems that support integrated graphics, in addition to the MRC change, the Intel graphics driver must also be updated to revision 15.13.3.1787 or later for Microsoft* Windows Vista* and 14.38.6.5082 or later for Microsoft* Windows XP*.

Intel recommends that the OEM minimizes exposure to this issue by updating the MRC/BIOS and graphics driver.



Status: No Fix.

10. Mobile Intel® GM45/GS45 Express Chipset, Intel® Flex Memory Technology & Intel® Virtualization Technology (Intel® VT) for Directed I/O (Intel® VT-d) Compatibility Issue

Problem: Systems using the Intel® GM45/GS45 Express Chipset with integrated graphics and Intel® VT-d enabled may experience visual corruption with Intel® Flex Memory Technology configurations.

Implication: Display corruption is observed when using integrated graphics with Microsoft* Windows Vista* or Microsoft* Windows7* with Intel® VT-d enabled and using Intel® Flex Memory Technology configurations.

Systems using discrete graphics, or Microsoft* Windows XP*, or single channel (non-interleaved), or dual-channel symmetric (interleaved) memory configurations are not affected.

Workaround: None.

For systems supporting integrated graphics and Intel® VT-d enabled:

- Use only symmetric memory (Interleaved) configurations, or single channel (non-interleaved) memory configurations.
- Or, disable Intel® VT-d.

Status: No Fix.

11. Mobile Intel® 4 Series Express Chipsets Integrated Graphics Overlay Display Corruption Issue

Problem: The Mobile Intel® GM45/GL40/GS45/GS40 Express Chipsets may not be able to supply pixels to overlay on pipe A after overlay was previously enabled and then disabled on pipe B.

Implication: Video overlay display corruption in Extended Desktop mode with Microsoft* Windows Vista* or Windows 7* is possibly observed when video media playback is moved between 2 display devices with video overlay scaling enabled.

Systems using Microsoft Windows XP* are not affected.

Workaround: A graphics driver update has been identified and may be implemented to mitigate this erratum.

Status: No Fix.

§



Specification Changes

There are no specification changes in this Specification Update revision.

§



Specification Clarifications

There are no specification clarifications in this Specification Update revision.

§



Documentation Changes

Mobile Intel® 4 Series Express Chipset Family Datasheet Document# 320122

Changes are in **RED** font. These changes will be included in the next revision of the datasheet.

1. Intel® GS45 (Low-power) GFX Voltage

Table 23. Thermal Design Power Number

SKU	GFX/GMCH Core voltage (V)	Max GFX Core Frequency (MHz)	TDP (W)	Notes
Intel® GM45	1.05/1.05	533	12	1
Intel® GS45 (Low-power)	1.00 1.05/1.05	320	7	1,2
	1.05/1.05	533 (for playback)	8	1,2
Intel® GS45 (High-Performance)	1.05/1.05	533	12	1
Intel® GL40	1.05/1.05	400	12	1
Intel® GS40	1.05/1.05	400	12	1
Intel® PM45	0/1.05	NA	7	1

NOTES:

1. Thermal design power (TDP) does not represent the worst case possible power of the product and is not intended for power delivery or Icc,max specifications. TDP is an Intel characterized value intended to represent the maximum measured 5 second moving average power of the product while running typical application workloads and is useful for the product thermal design requirements. This characterized value is valid with the product Tj operation range and nominal Vcc.
2. FSB/DDR2 667 MHz/667 MHz and FSB/DDR3 800 MHz/800 MHz with no-ODT.